

**ONBOARD SYSTEMS
INTERNATIONAL**

13915 NW 3rd Court
Vancouver, WA 98685
USA

Phone: 360-546-3072
Fax: 360-546-3073
Toll Free: 800-275-0883

www.OnboardSystems.com

SERVICE BULLETIN

Document No. 159-011-00, Rev. 1
July 9, 2015

Subject: Cargo Hook enhanced safety.

Helicopters Affected: All aircraft with 28 Volt electrical systems and Onboard Systems 3.5K Keeperless Hook, part number 528-023-00, installed. This service bulletin **does not** apply to 12 Volt aircraft such as the Robinson R22 and most Robinson R44s.

Affected Kit Numbers: 200-258-00, 200-259-00, 200-259-01, 200-260-00, 200-261-00, 200-264-00, 200-267-00, 200-268-00, 200-269-00, 200-269-02, 200-270-00, 200-271-00, 200-280-00, 200-281-00, 200-282-00, 200-288-00, 200-289-00, 200-290-00, 200-291-00

Affected Hook P/N: 528-023-00

Compliance: Optional

Description: The cargo hook, based on reports from the field, has exhibited inconsistent re-latching of its internal release mechanism. The problems have been traced to an internal spring, which is used to retract the release mechanism and manual release cable after a load is released. Upon further investigation it has been concluded that due to manufacturing inconsistencies some of the springs do not provide an adequate retract force or have a tendency to work their way out of their optimal operating position. In the event of this occurrence, the result may be an incomplete locking of the mechanism. This could lead to an inadvertent load release.

This service bulletin contains instructions for replacing the existing spring with a new spring and spring retainer. The new spring is of a design that provides a higher retract force. The spring retainer ensures that the spring is maintained in its proper position.

The actions required by this service bulletin are described below.

Approval: The engineering design aspects of this bulletin are FAA/DER approved.

Manpower: Replacement of the spring will require 1.0 man-hours. Man-hours are based on hands-on time and may vary with personnel and facilities available. No machining operations are required. Installation consists of removing and replacing parts and re-identifying the cargo hook as a 528-023-01.



Required Material: The following material is required for accomplishment of this bulletin and may be obtained from Onboard Systems:

Qty 1 P/N 514-056-00 Spring Assembly

Qty 1 P/N 290-819-00 Spring Retainer

Qty 2 P/N 510-115-00 Cotter Pin

.032” Lockwire

Special Tools: Not required

Weight and Balance: Not affected

Electrical Load Data: Not affected

Publications Affected:

Owner's Manuals
120-092-00
120-093-00
120-094-00
120-096-00
120-098-00
120-099-00
120-100-00
120-104-00
120-105-00
120-106-00
120-110-00
120-111-00

Service Manual(s)
122-005-00

Instructions for Continued Airworthiness
123-001-00
123-002-00
123-003-00
123-007-00
123-011-00
123-012-00
123-013-00
123-016-00

The changes to these publications consist of adding new part numbers for the spring and spring retainer where applicable and the 528-023-00 cargo hook part number with 528-023-01. Operation and maintenance of the new 528-023-01 cargo hook is unchanged from the original 528-023-00.

Accomplishment Instructions:

To be accomplished within 60 days of the release of this service bulletin.

For Cargo Hook with serial numbers 328, 332, 334, 336, 337, 338, and 339:

Re-identify the cargo hook as P/N 528-023-01 by steel stamping a “1” over the last 0 in the P/N on the identification plate located on the outside of the solenoid assembly per step 14 of this service bulletin. The internal parts are of the new configuration.

For all other serial numbers:

Remove spring and replace with spring assembly and retainer per included instructions beginning at step 1.

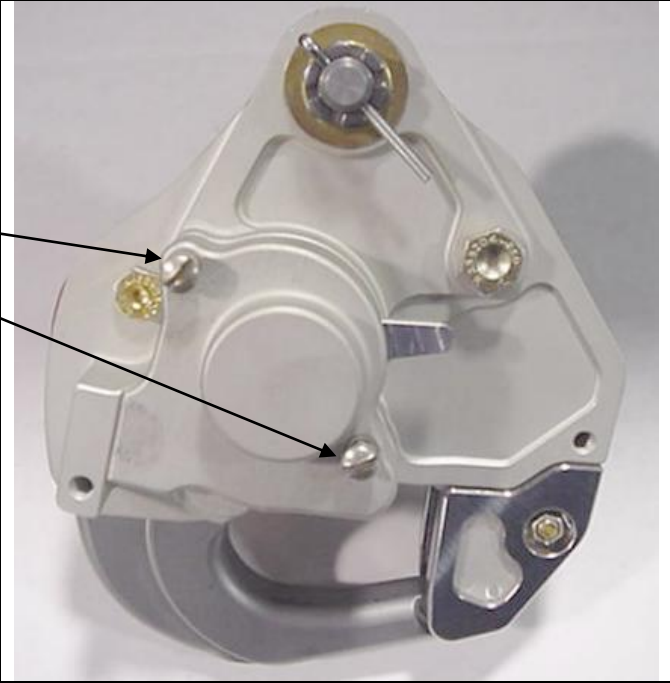
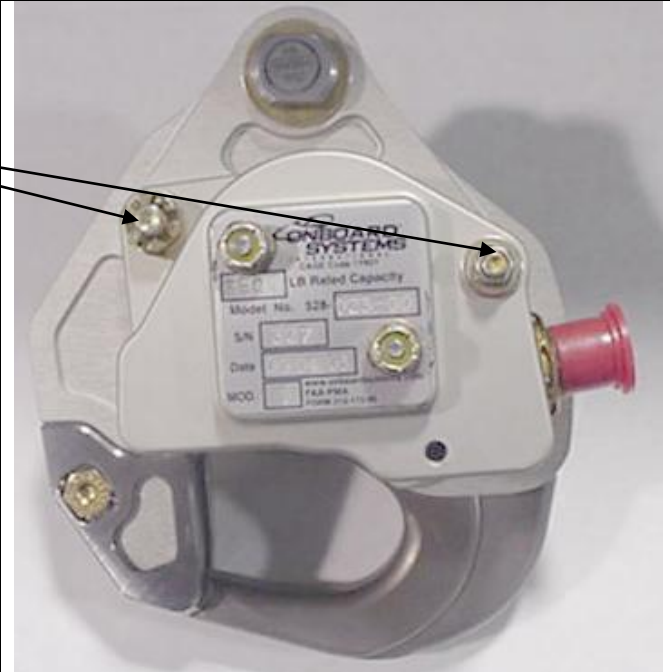
<p>Step 1</p> <p>Remove manual release cover by cutting and removing lock wire if present and removing two screws.</p>	
<p>Step 2</p> <p>Remove solenoid assembly by removing cotter pin, nuts, and washers.</p>	

Step 3

Step 2 allows access to head of this bolt.



Step 4

Remove cotter pin, nut, and washer from bolt.

Then remove manual release lever.

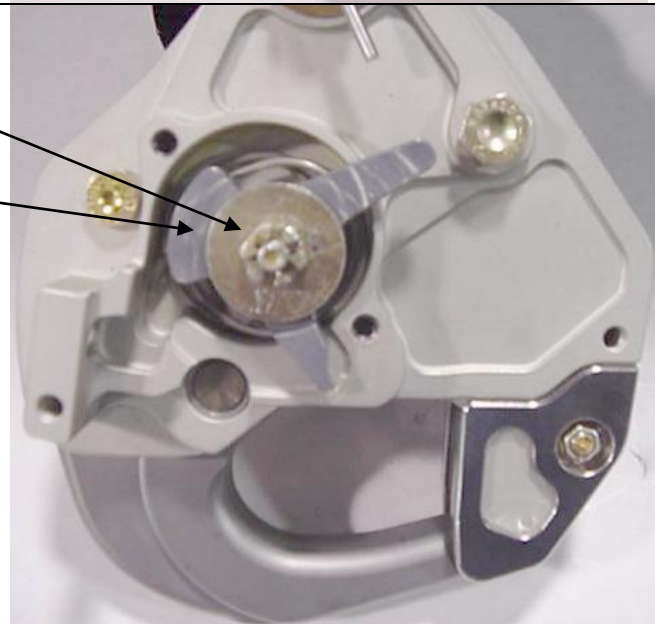

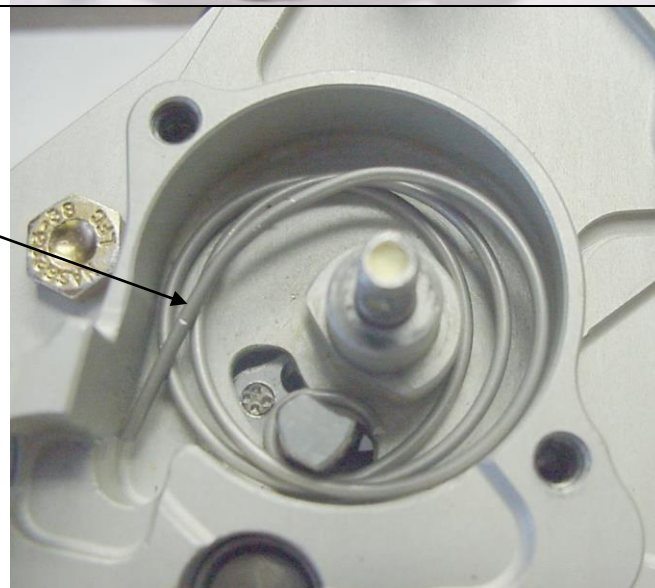

Step 5

Remove and discard old spring.

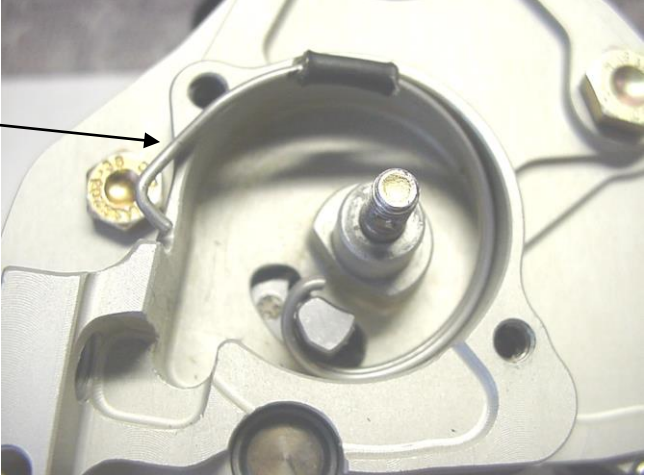

Note: For S/N 322, 324, 325, 326, 329, 330, and 331 discard old springs and old retainer.

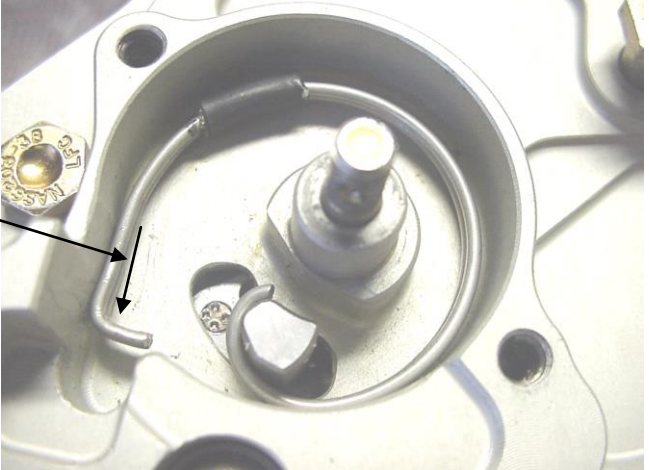
<p>Step 6</p> <p>Insert new spring assembly, into side plate pocket.</p>	
<p>Step 7</p> <p>Apply gentle pressure over and in to insert spring assembly into pocket.</p>	
<p>Step 8</p> <p>Spring assembly should fall into pocket with ease.</p>	
<p>Step 9</p> <p>Pre-load spring assembly by pulling end down within the spring cavity.</p>	

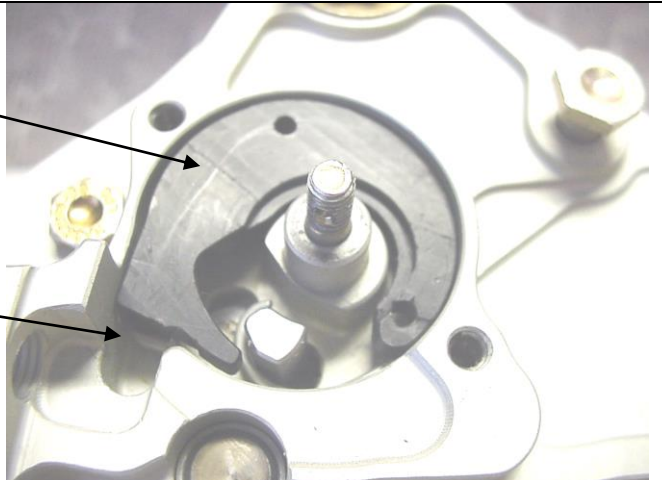
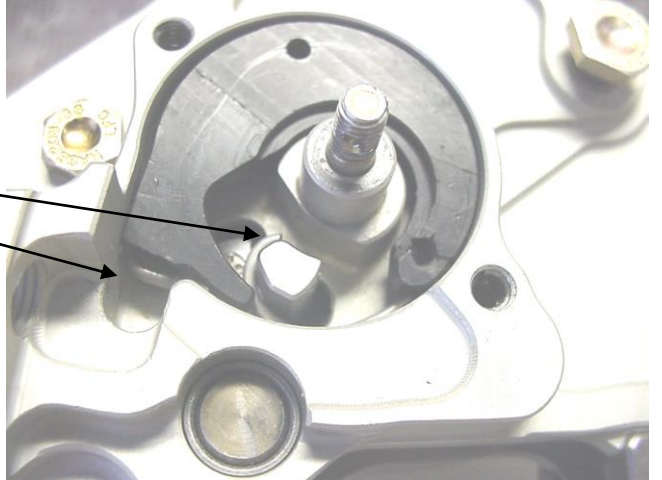
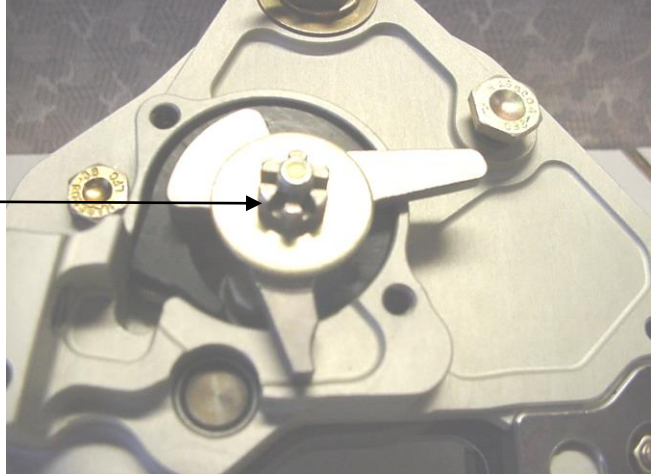
<p>Step 10</p> <p>Place spring retainer over spring assembly.</p> <p>If spring retainer does not lay flat, verify that the spring legs have been pulled down far enough. End of spring assembly should be visible below retainer.</p>	
<p>Step 11</p> <p>Visually check the position of the spring assembly.</p>	
<p>Step 12</p> <p>Install manual release lever and secure with washer, nut, and cotter pin. Tighten nut finger tight and then rotate to next castellation to insert cotter pin.</p>	

Step 13

Fasten solenoid assembly onto side plate with washers, nut, and cotter pin.

Torque first nut to 15 in-lbs. and rotate to next castellation to insert cotter pin.

Torque second nut to 20-25 in-lbs.

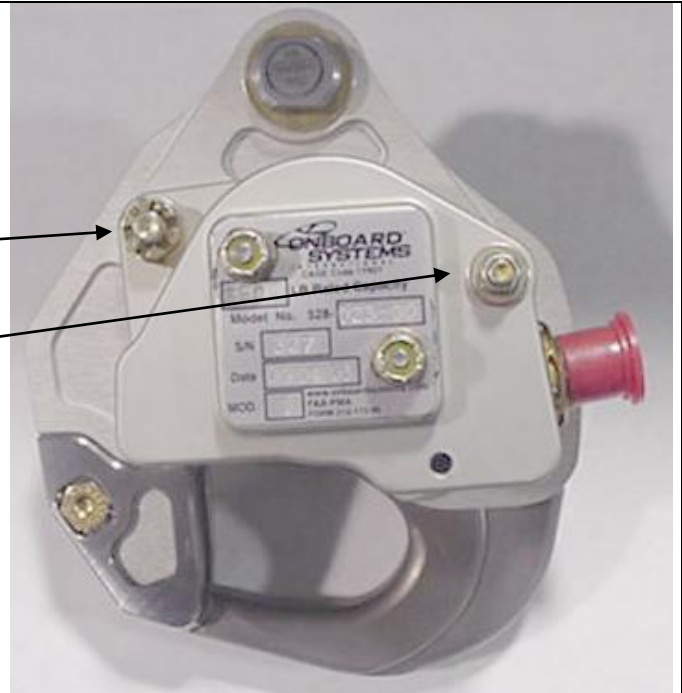

Step 14

Re-identify the cargo hook as P/N 528-023-01 by steel stamping a “1” over the last 0 in the P/N on the identification plate located on the outside of the solenoid assembly.

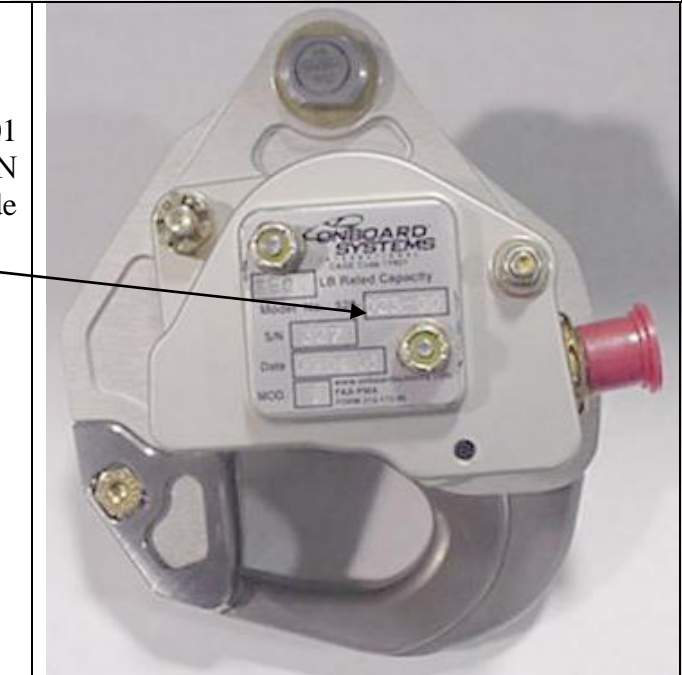

Re-install Cargo Hook on Aircraft per Hook Owners manual instruction or ICA.

Place the cable into the fork on the manual release lever as illustrated. Verify correct setting per the following. Move the manual release lever in the clockwise direction until free play is removed. Measure the cable ball end free play with the manual release handle in the cockpit in the non-release position. The gap should measure approximately 1/8"

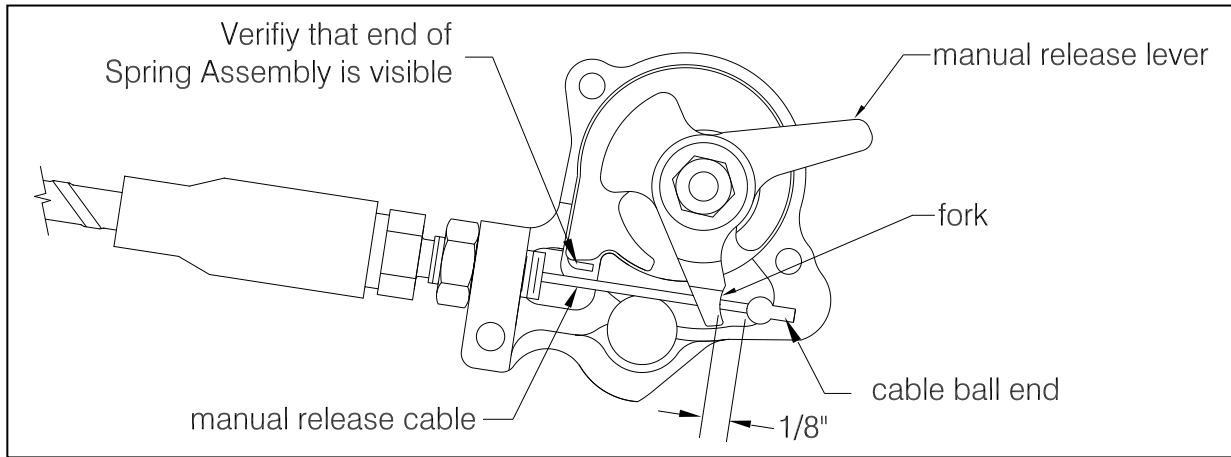

Record compliance with this service bulletin in the aircraft logbook as appropriate.