

**PLEASE CHECK WEB SITE AT WWW.ONBOARDSYSTEMS.COM FOR
THE LATEST REVISION OF THIS MANUAL**

E-51 LOAD WEIGH SYSTEM

For The

MD Helicopters

**369D, 369E, 369F, 369FF,
369HE, 369HM, 369HS, 500N, 600N
Models**

Owner's Manual

Owner's Manual Number 120-017-00

Revision 11

February 21, 2018



13915 NW 3rd Court Vancouver, Washington 98685 USA
Phone: 360-546-3072 Fax: 360-546-3073 Toll Free: 800-275-0883
www.OnboardSystems.com

This page intentionally left blank.

RECORD OF REVISIONS

<i>Revision</i>	<i>Date</i>	<i>Page(s)</i>	<i>Reason for Revision</i>
6	08/11/06	1-4 Section 2 Section 4 Section 5	Added additional kit, load cell assembly, harness assembly, and RFMS to Bill of Materials Added additional release cable routing instructions. Re-organized installation instructions. Added Figure 2-3. Updated weights in Table 2-1. Added additional kit inspection criteria. Updated inspection intervals. Removed RFMS (created new document number 121-035-00).
7	10/18/07	TOC, Section 1, 2-3, 2-6, 3-7, 3-8, 3-9, 4-3 and 4-4	Added explanation of warnings, cautions and notes to Section 1. Updated warnings, cautions and notes throughout.
8	08/28/08	1-1, 1-4, 2-1, 2-2, 2-5, 2-6, 4-4, 4-5.	Added 600N model, kit P/N 200-034-02 and load cell assembly p/n 210-031-02. Clarified internal harness connector installation instructions.
9	3/2/10	TOC, Section 2 & Section 4	Updated manual to reflect new load weigh harness configuration. Changed overhaul frequency criteria.
10	10/14/10	All	Added P/N 210-095-04 as an optional indicator, updated components weights table, updated format of safety labels throughout document.
11	2/21/18	Page 4-1 through 4-4	Updated 5 year/1000 hour inspection actions. Removed requirement to perform magnetic particle inspection of load cell, removed daily check, updated definition of “hours of external load operations” .

Register Your Products for Automatic Notifications

Onboard Systems offers a free notification service via fax or email for product alerts and documentation updates. By registering your Onboard Systems products at our website, we will be able to contact you if a service bulletin is issued, or if the documentation is updated.

You can choose to receive notices on an immediate, weekly, or monthly schedule via fax, email or both methods. There is no charge for this service. Please visit our website at www.onboardsystems.com/notify.php to get started.

This page intentionally left blank.

CONTENTS

***Section 1* General Information**

Introduction, **1-1**
Safety Labels, **1-1**
Indicator Features, **1-2**
Indicator Specifications, **1-2**
Indicator Pin Out, **1-3**
Load Cell Specifications, **1-3**
Bill of Materials, **1-4**
Inspection, **1-4**

***Section 2* Installation Instructions**

Introduction, **2-1**
System Installation Overview, **2-1**
Internal Harness Installation, **2-2**
Electrical Connections, **2-2**
Indicator Installation, **2-4**
Indicator Internal Back Light, **2-4**
Indicator Hook-Open Warning, **2-4**
Remote Analog Meter, **2-4**
Load Cell Installation, **2-5**
Installation Check-Out, **2-7**
Component Weights, **2-7**
Paper Work, **2-7**

***Section 3* Operation Instructions**

Indicator Front Panel, **3-1**
The Run Mode, **3-2**
 To Zero or Tare the Display, **3-3**
 To Un-Zero the Display, **3-3**
 Error Codes, **3-4**
The Setup Mode, **3-5**
 Indicator Dampening, **3-7**
 To look at or change the dampening level, **3-7**
 Indicator Calibration, **3-7**
 To look at or change the calibration code, **3-8**
 Installation Zero, **3-9**
 To run the installation zero routine, **3-9**

***Section 3 (cont.)* Operation Instructions**

Calibration by Lifting a Known Weight, **3-9**

To run calibration by a known weight routine, **3-10**

Setting the Scale on a Remote Analog Meter, **3-11**

To look at or change the scale, **3-11**

Select KG or LB Units, **3-12**

To look at or change the units, **3-12**

Indicator Version, **3-13**

***Section 4* Maintenance**

Lubrication, **4-1**

Inspection, **4-2**

Trouble Shooting, **4-5**

Instructions for Returning a System to the Factory, **4-6**

***Section 5* Certification**

STC, **5-1**

STA, **5-3**

EASA STC, **5-4**

Figures

2-1 Load Weigh System Installation Overview, **2-1**

2-2 Wiring Arrangement, **2-3**

2-3 Load Cell Installation, **2-5**

3-1 Front Panel, **3-1**

3-2 After Diagnostic Routine, **3-2**

3-3 LB Legend Displayed, **3-2**

3-4 Zeroing the Display, **3-3**

3-5 Changing Dampening Level, **3-7**

3-6 Changing the CAL Code, **3-8**

3-7 Running CAL Routine, **3-10**

3-8 Entering Load in CAL Routine, **3-10**

3-9 Changing the Scale, **3-11**

3-10 Changing the Units, **3-12**

3-11 Looking at Indicator Version, **3-13**

4-1 Load Cell Components, **4-5**

Tables

- 1-1 Indicator Specifications, **1-2**
- 1-2 Indicator Pin Out, **1-3**
- 1-3 Load Cell Specifications, **1-3**
- 1-4 Bill of Materials, **1-4**
- 2-1 Component Weights, **2-7**
- 3-1 Indicator Error Codes, **3-4**
- 3-2 Indicator Setup Routines, **3-6**
- 4-1 Inspection Criteria, **4-4**
- 4-2 Trouble Shooting, **4-5**

This page intentionally left blank.

Section 1

General Information

Introduction

The P/N 200-034-00 and P/N 200-034-01 Load Weigh Systems are intended for installation on the MD Helicopters 369 series and 500N helicopters. The P/N 200-034-02 Load Weigh System is intended for installation on the 600N model.

The Load Weigh System is a compliment to the helicopter lifting system. Its purpose is to display the weight of the load carried on the cargo hook. The Load Weigh System consists of three components, the cockpit mounted Indicator, the Internal Harness and the Load Cell. The system is designed specifically for each helicopter and is intended to be a permanent installation.

Safety Labels

The following definitions apply to safety labels used in this manual.



Indicates a hazardous situation which, if not avoided, will result in death or serious injury.



Indicates a hazardous situation which, if not avoided, could result in death or serious injury.



Indicates a hazardous situation which, if not avoided, could result in minor or moderate injury.



Draws the reader's attention to important or unusual information not directly related to safety.



Used to address practices not related to personal injury.

Indicator Features

The features of the C-39 Indicator include:

- Front panel programmable
- Data Recorder communications link
- Internal back lighting system
- Night Vision Compatible (NVG) When an external NVG source is used in place of the internal back light.
- Hook-Open Warning Display
- Analog Meter Output Signal

Indicator Specifications

Table 1-1 Indicator Specifications

Size	Fits standard 2¼" clock hole
Weight	.44 lbs (.20 kgs)
Operating Voltage	21 to 31 VDC
Current Consumption	< 25 mA
Accuracy Over Operating Temperature Range	0.1% ± 1 digit
Operating Temperature Range	+70°C to -45°C
Storage Temperature Range	+80°C to -50°C
Scaleable Analog Output	0 to 5VDC ± 0.5%

Indicator Pin Out

The connector located on the back of the Indicator has the following pin out.

Table 1-2 Indicator Pin Out

Pin Letter	Function
A	+ 28 VDC In
B	- Load Cell Signal
C	+ Load Cell Signal
D	+ Load Cell Excitation
E	Load Cell Common
F	Analog Out Common
G	+ Analog Out
H	Hook Open
J	Data Recorder Clock
K	Data Recorder Data
L	Shield
M	Back Light Common
N	Back Light Source 28 VDC
P	Aircraft Ground
R	Not Used

Load Cell Specifications

Table 1-3 Load Cell Specifications

Weight	.75 lbs (.34 kgs)
Accuracy Over Operating Temperature Range	0.5% \pm 1 digit
Operating Temperature Range	+70°C to -45°C
Storage Temperature Range	+80°C to -50°C

Bill Of Materials

The following items are included with each system, if shortages are found contact the distributor from whom the system was purchased.

Table 1-4 Bill of Materials

Part No.	Description	200-034-00 Qty	200-034-01 Qty	200-034-02 Qty
120-017-00	Owner's Manual	1	1	1
121-035-00	RFMS	1	1	1
210-095-00	C-39 Indicator	1	1	1
210-095-04*	C-39 Indicator, NVG	Opt.	Opt.	Opt.
210-031-00	E-51 Load Cell Assembly	1	-	-
210-031-01	E-51 Load Cell Assembly	-	1	-
210-031-02	E-51 Load Cell Assembly	-	-	1
270-047-00	Harness Assembly	1	-	-
270-047-01	Harness Assembly	-	1	1
400-048-00	Power Switch	1	1	1
215-010-00	Placard	2	2	2
215-012-00	Placard	1	1	1
512-001-00	Ty-Wrap	10	10	10
510-028-00	Screw	4	4	4
510-029-00	Nut	4	4	4
510-062-00	Washer	8	8	8
510-068-00	Bolt	1	1	1
510-036-00	Nut	1	1	1
510-067-00	Cotter Pin	1	1	1

** The 210-095-04 Indicator is equipped with NVG compatible lights. It is an optional indicator that can be used in place of the 210-095-00 Indicator.*

Inspection

Inspect each component for evidence of mishandling and damage. If damage is evident, do not use it. File a claim with the carrier and notify the distributor from whom the system was purchased.

Section 2

Installation Instructions

Introduction

These procedures are provided for the benefit of experienced aircraft maintenance facilities capable of carrying out the procedures. They must not be attempted by those lacking the necessary expertise.

This section describes how to install the components of the Electronic Load Weigh System.

System Installation Overview

The following diagram is an overview of the load weigh system installation.

Figure 2-1 Load Weigh System Installation Overview

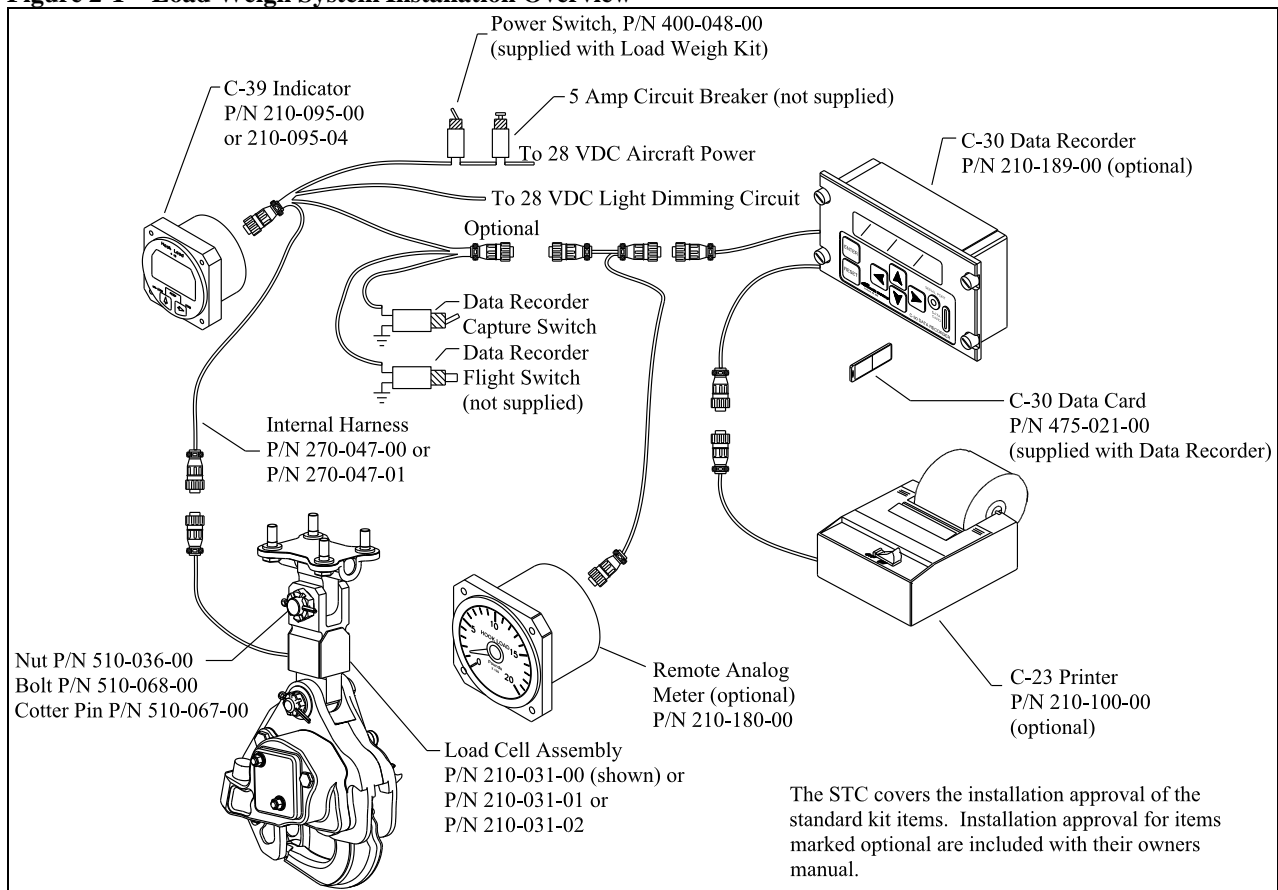

Internal Harness Installation

The Internal Harness is made up of four cables terminated to one connector. The connector is plugged into the back of the Indicator. One of the cables is marked "LOAD CELL" and is fitted with a bulkhead fitting. This cable is connected to the load cell cable. Another cable is marked "POWER" and is connected to the aircraft electrical power. Another cable is marked "LIGHT", refer to the *Indicator Internal Back Light* section for installation instructions. The last cable is marked "DATA" and can be connected to the optional Data Recorder or Analog Slave Meter. These items are not included under this STC.



The data cable may or may not be terminated with a connector depending on manufacture date.

To install the load cell bulkhead connector locate a convenient position directly aft of the existing hole in the aircraft skin that allows the manual release cable to pass through (under the pilot's seat). Layout the connector hole pattern and drill the required holes. Install the bulkhead connector with the supplied hardware.

Secure the cables clear of flight control rods.

Electrical Connections

Install the supplied power switch, part number 400-048-00. The "POWER" cable on the Internal Harness is supplied extra long, cut off the excess cable and use as needed to connect the switch and circuit breaker. Connect the "POWER" white (or red if earlier configuration of harness (P/N 270-047-00) is installed)) wire to one side of the power switch, connect another piece of suitable wire to the other side of the switch and then to an available 1 or 2 amp circuit breaker as illustrated in Figure 2-2. Connect the circuit breaker to the 28 VDC bus. Connect the White/Blue (or black) wire to ground. Use a minimum of 22 gauge wire to make all connections. Secure the connections and protect from corrosion.

The following figure shows the wiring arrangement for harness P/N 270-047-01 (wire colors for harness P/N 270-047-00 are shown in parentheses).

Electrical Connections continued

Figure 2-2 Wiring Arrangement

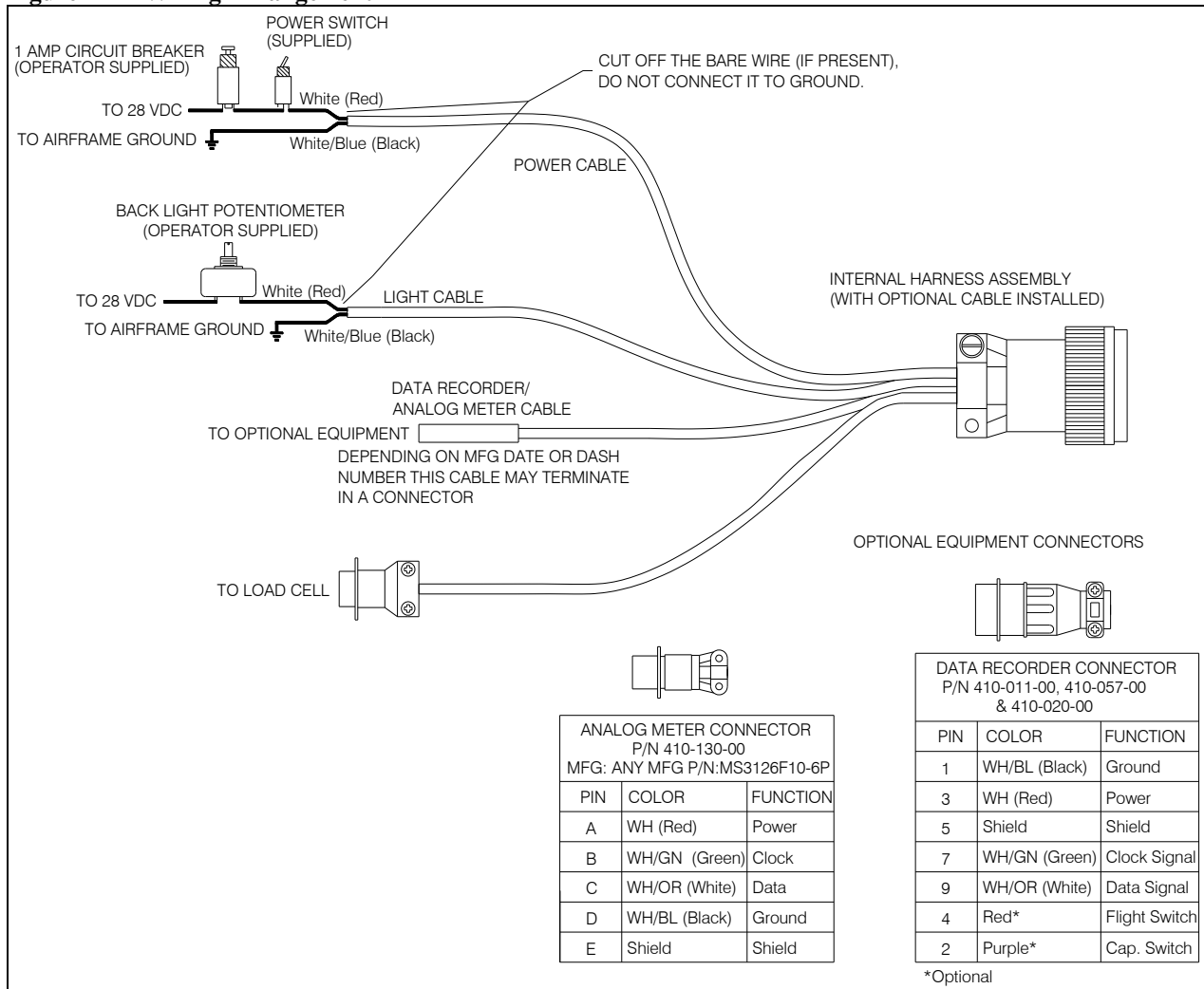

Connect the Internal Harness to the Indicator connector. Install the placard 215-010-00 “ELECTRONIC WEIGHING SYSTEM” next to the power switch and circuit breaker. Install the placard 215-012-00 “TURN THE WEIGHING SYSTEM OFF WHEN NAVIGATION EQUIPMENT IS IN USE. NO AIRCRAFT OPERATION SHOULD BE PREDICATED ON THE READING OF THE ONBOARD WEIGHING SYSTEM” next to the Indicator.

NOTICE

If the C-23 Printer is being utilized with the C-30 Data Recorder, a 5 amp circuit breaker should be used.

Indicator Installation

The Indicator should be mounted in a position that is convenient, accessible and visible to the pilot. It can be mounted in a standard 2¼" instrument hole. Connect the Indicator to its Internal Harness, refer to *Internal Harness Installation*.

Indicator Internal Back Light

The 210-095-00 Indicator is equipped with an Internal Back Lighting System that can be connected to the aircraft 28 VDC light dimming circuit. Use a 22 gauge, twisted pair, shielded cable to connect the aircraft dimming circuit to the Internal Harness. Connect the cable shield wire to airframe ground at the light dimmer end of the cable **ONLY**.

Indicator Hook-Open Warning

The 210-095-00 Indicator is equipped with a Hook-Open Warning feature that can be connected to a cargo hook equipped with a hook open switch. Depending on the capabilities of the cargo hook switch, the Indicator will flash "HOOK OPEN" when the cargo hook load beam is open. The cargo hook switch must be normally open when the cargo hook load beam is in the closed position. When the load beam is open, one side of the switch must be grounded and the other side of the switch is to be connected to the Indicator. Use a 22 gauge, shielded wire to connect the cargo hook switch to the Indicator. Disassemble the Indicator mating connector and carefully solder the wire, from the cargo hook switch, to pin H. Connect the cable shield wire to airframe ground as close to the cargo hook as possible, at the cargo hook end of the cable **ONLY**.

Remote Analog Meter

The 210-095-00 Indicator is equipped with an Analog drive circuit that can be connected to a remote analog meter. Use a 22 gauge, twisted pair, shielded cable to connect the remote Analog Meter to the Indicator. Disassemble the Indicator mating connector and carefully solder the positive wire, from the analog meter, to pin G and the common wire to pin F. Connect the cable shield wire to airframe ground as close to the Analog Meter as possible, at the Analog Meter end of the cable **ONLY**.

The 210-095-00 Indicator can be connected to Onboard Systems' Analog Slave Meter, P/N 210-180-00, through the "DATA" cable. This meter gives solid weight indications without needle bounce. The Analog Slave Meter may be mounted in any convenient location in a standard 3" instrument hole. Attach connector, P/N 410-130-00, to data line per pin out (Figure 2-2) to connect the Analog Slave Meter to the Internal Harness "DATA" cable. If a data connector is present on the data line use cable, P/N 270-059-00, to connect to Analog Slave Meter.

Load Cell Installation

Remove the cargo hook from the gimbal that attaches it to the aircraft. Leave the gimbal attached to the aircraft and the manual release cable and electrical release harness attached to the cargo hook. Attach the load cell lower lug to the cargo hook using the hardware removed in the previous step. The electrical cable should point forward.

Attach the load cell upper clevis to the gimbal using the hardware provided (see Figure 2-3). Hand tighten the nut, **loosen** it one turn and install the cotter pin. This prevents the fastener from squeezing the clevis end of the load cell, causing the load cell to give a false indication of load.

Figure 2-3 Load Cell Installation

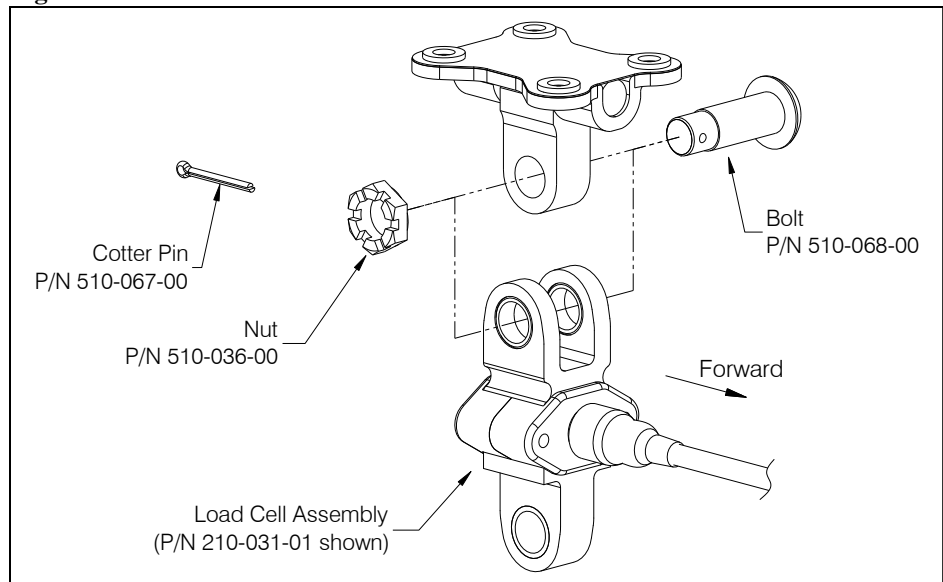

Load Cell Installation continued

Route with and secure the load cell electrical harness to the cargo hook electrical release harness with ty-wraps.

Since the installation of the load cell lowers the cargo hook it is important to ensure that the electrical release harness and the manual release cable are routed effectively. If installing the load cell on an 369 series or 500N model helicopter equipped with the 369H92105-501 cargo hook assembly, verify that the manual release cable is an MD Helicopters part no. 14323-2.



Swing the hook/load cell assembly to its full extremes while observing the manual release cable, the load cell electrical harness and the cargo hook electrical release harness. Verify that the electrical harnesses and the manual release cable do not prevent the cargo hook from moving throughout its range of motion.



Un-commanded cargo hook release will happen if the manual release cable is improperly restrained. The manual release cable must not be the stops that prevent the Cargo Hook from swinging freely in all directions. If the Cargo Hook loads cause the hook to strain against the manual release cable the swaged end of the cable may separate allowing the inner cable to activate the cargo hook manual release mechanism. The result is an un-commanded release. Ensure that no combination of cyclic stick or cargo hook position is restrained by the manual release cable.

Installation Check-Out

After the system has been properly installed, activate the circuit breaker to turn the system on. Refer to *Operation Instructions*.

Perform an EMI ground test per AC 43.13-lb section 11-107. For equipment that can only be checked in flight an EMI flight test may be required.



The load cell is of a class of equipment not known to have a high potential for interference. This class of equipment does not require special EMI installation testing (i.e. FADEC) as required in paragraphs 7 and 8 of FAA policy memorandum ASW-2001-02.

Cycle the manual release mechanism to verify proper operation.

Ensure that the cargo hook is free to move to its full extremes.

Ensure that all electrical harnesses are secured clear of flight control rods and hydraulic lines.

Component Weights

Table 2-1 Component Weights

Item	Weights	
	Kit P/N 200-034-00, -01	Kit P/N 200-034-02
Indicator	.47 lbs (.21 kgs)	.47 lbs (.21 kgs)
Load Cell	.80 lbs (.36 kgs)	.87 lbs (.39 kgs)
Internal Harness	.53 lbs (.24 kgs)	.53 lbs (.24 kgs)
Hardware	.14 lbs (.06 kgs)	.14 lbs (.06 kgs)
Total	1.94 lbs (.88 kgs)	2.01 lbs (.91 kgs)

Paper Work

Insert the Flight Manual Supplement 121-035-00 into the aircraft flight manual. In the US fill in FAA form 337 for the initial installation. This procedure may vary in different countries. Make the appropriate aircraft log book entry.

This page intentionally left blank.

Section 3

Operation Instructions

Load Weigh System

Indicator Front Panel

The C-39 Indicator front panel includes the following features.

- The four 7 segment LCD digits show the weight on the Cargo Hook and displays various Setup information.
- The Legends clarify the digital display. i.e. when the LB Legend is turned on, the display will be pounds, etc.
- The Right button is used to Zero the display in the Run Mode and select the digit to be changed in the Setup Mode.
- The Left button is used to Un-Zero the display in the Run Mode and scroll the selected digit in the Setup Mode.

Figure 3-1 Front Panel

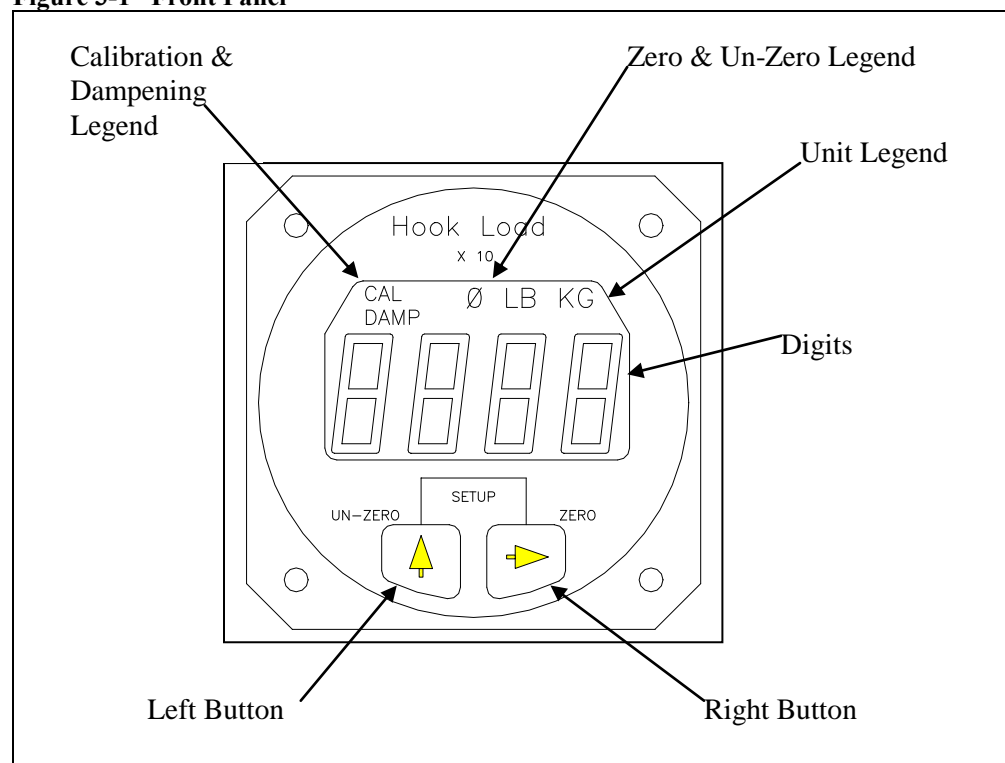

The Run Mode

The C-39 Indicator has two operating modes, Run and Setup. The Run Mode is used to display the cargo hook weight and the Setup Mode is used to setup or configure the Indicator to the helicopter and to the Load Cell. When powered up, the Indicator always comes to life in the Run Mode.

After the Indicator has been correctly installed, power it up by activating the Load Weigh Circuit Breaker. The Indicator will go through a self diagnostic routine. During this routine the display will display all of the digits and legends. If a problem is found during the routine an Error Code will be displayed. For an explanation of Error Codes see the section *Error Codes*. After the diagnostic routine the display should look like this:

Figure 3-2 After Diagnostic Routine

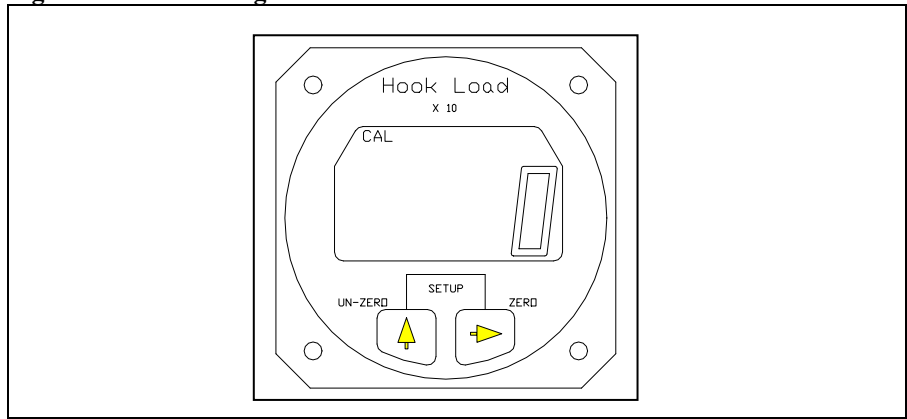

The illustration is of the Indicator in the Run Mode with no load on the hook. Note the LB legend displayed.

Figure 3-3 LB Legend Displayed

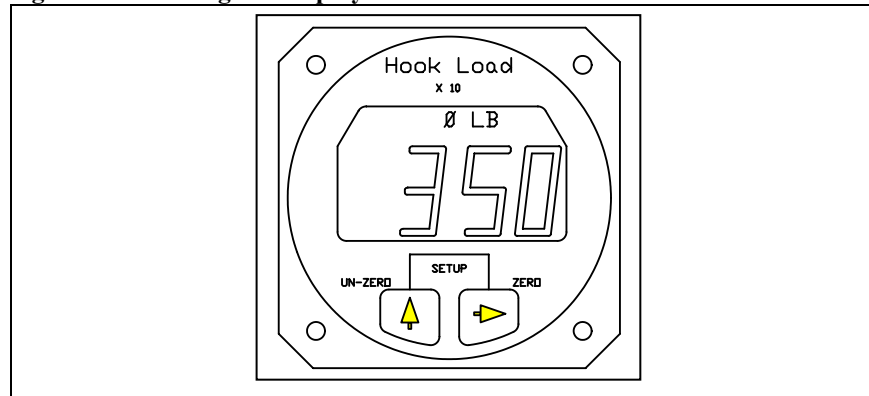

The illustration is a typical hook load reading. The display is 3,500 pounds, note the last digit is not displayed.

To Zero or Tare the Display

The zero feature is used to zero or tare the weight on the Cargo Hook that is not wanted, such as the weight of a cargo net or long line. The Right button is used to zero the Indicator reading. When the Right button is pressed the display is zeroed. The zero legend is turned on and the zeroed number is stored in memory. If the Right button is pressed again, before the Un-zero button is pressed, the display blinks in response to the button closure. Zero is only available in the Run Mode.

Figure 3-4 Zeroing the Display

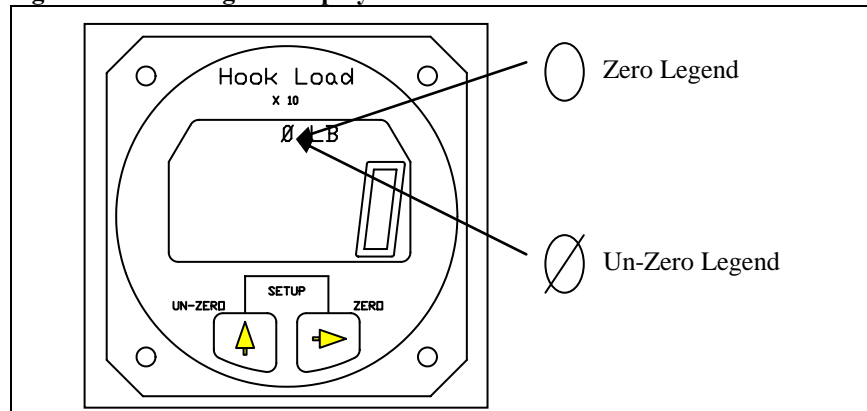

To Un-Zero the Display

The Left button is used to add the zeroed value back into the current Indicator reading or Un-zero the display. When the Left button is pressed, the number previously zeroed is added to the current display and the Un-zero legend is turned on. If the Left button is again pressed before the zero button is pressed, the display blinks in response to the button closure. Un-Zero is only available in the Run Mode.

Error Codes

Error Codes are the result of difficulties discovered during the Indicator diagnostic tests. Diagnostic tests occur at power up and during the execution of certain routines. Listed below is a matrix of the Error Code displays, their meaning and possible corrective action. Pressing either button will usually bypass the error code, however, the displayed information may be suspect.

Table 3-1 Indicator Error Codes

DISPLAY	CAUSE	POSSIBLE CORRECTIVE ACTION
Err 1	A/D or D/A circuit failure	Potential short in the optional analog meter cable. Clear short and power cycle the Indicator by turning the power to the Indicator off for a few moments. If Error Code continues, return the Indicator to the factory.
Err 2	NV Ram failure	Power cycle the Indicator; if Error Code continues, return the Indicator to the factory.
Err 3	NV Ram write failure	Re-enter data, if Error Code continues, return the Indicator to the factory.
Err 4	NV Ram busy failure	Power cycle the Indicator, if Error Code continues return the Indicator to the factory.

The Setup Mode

The C-39 Indicator can be used with a wide range of helicopters and load cells. The Setup Mode on the Indicator matches the Indicator to the Load Cell and to the helicopter. This is done by entering data into the Indicator. Entered data includes the load cell Calibration Code, the units that the Indicator should read-out (pounds or kilograms), and several other items.

The Indicator has a group of Setup routines, arranged in menu form, that are used to configure the Indicator. Shown on the next page is a matrix of the Setup routines and a brief discussion of their function and how they are programmed. A complete discussion of each setup item is presented later in this section.

To enter the Setup Mode press both the Right and Left buttons at the same time while the Indicator is powered up and in the Run Mode. To exit the Setup Mode and return to the Run Mode, press both the buttons at the same time. If you are in a Setup routine and have started to change an entry, but you change your mind before completing the procedure, power cycle the Indicator to exit the Setup Mode and then go to the Run Mode without changing the item. The Indicator is power cycled by turning the Indicator power off for a few moments.

The Setup Mode, continued

Table 3-2 Indicator Setup Routines

MENU	FUNCTION	DISPLAY
Press the Left button to scroll through the menu	Press the Right button to view or change the menu item.	To return to the Run Mode press both the Right and Left buttons at the same time.
DAMP	<u>Dampening Level</u> , sets the pilots preference for display dampening.	Blinking display is previously entered Dampening Level. Select the desired dampening level by pressing the Left button.
CODE	<u>Calibration Code</u> , matches the Indicator to the Load Cell.	Display is previously entered CAL Code. The Code is changed by selecting the digit to be changed with the Right button. The selected digit will blink. Change the blinking digit by pressing the Left button.
0 in	<u>Installation ZERO</u> , matches the Indicator to the installed Load Cell and to the helicopter. After this procedure the display will be zero when no load is on the Cargo Hook.	Display is a combination of load on the Load Cell, and normal load cell zero offset. Remove all weight from the installed Load Cell except the Cargo Hook, and press any button to complete the procedure and return to the Run Mode.
LOAD	<u>Load</u> , is used to calibrate the system by lifting a known load.	No previous display is shown. Enter the known load using the Right button to select the digit to be changed and Left button to enter the number. Known load is entered "X 10" i.e.; 5000 kilograms is entered as 500. After the known load is entered, press both buttons at the same time and lift the known load. When the load is stabilized press either button. A new Calibration Code will be calculated and the known load will be displayed. This completes the procedure.
Scale	<u>Scale</u> , matches the analog output of the Indicator to an optional remote analog meter.	Display is previously entered number. To change the number use the Right button to select a digit, use the Left button to scroll the digit to the desired number. Entry is times 10.
LB KG	<u>Units</u> , selects the Indicator units (pounds or kilograms).	Display is previously selected unit. To change the unit, use the Left button.
XX - V	<u>Version</u> , is the revision level of the Indicator hardware and software.	Version is for information only, it cannot be changed.

Indicator Dampening

The Damp or dampening routine allows the pilot to adjust the Indicator dampening level to his preference. The dampening routine is a program that stabilizes the Indicator reading. It offers a trade-off between Indicator responsiveness and stability. Ten dampening levels are available, from 0 through 9. At level 0 the display responds to the slightest change in weight. However, if the load bounced even slightly, the display digits would respond instantly, making the display look unstable. With a dampening level of 9, the display would be stable under the most turbulent conditions, however, it would take several seconds for the display to respond to a change in weight. The ideal dampening level will depend on the flying conditions. A mid range setting of 5 or 6 is usually adequate.

To Look at or Change the Dampening Level

With the Indicator powered up and in the Run Mode, press both buttons at the same time to go to Setup. Scroll through the menu, using the Left button, until the word DAMP is displayed. To look at or change the Dampening Level press the Right button. The display should look like this:

Figure 3-5 Changing Dampening Level

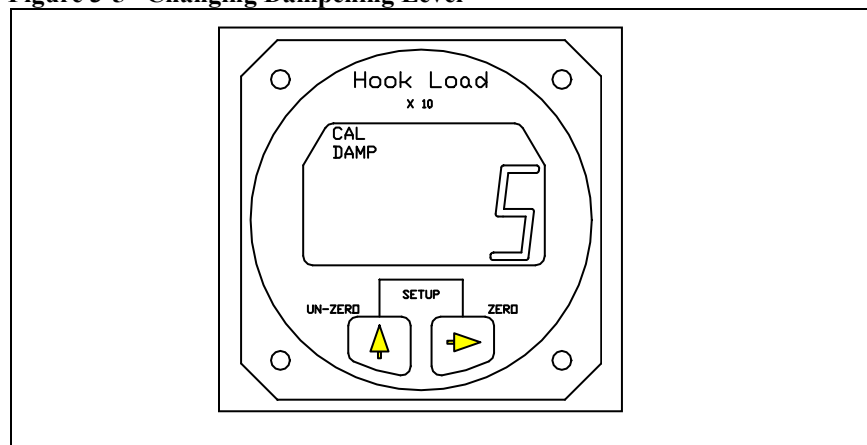

The CAL and the DAMP legend is turned on and the previously set dampening level is displayed. To return to Run without changing the current dampening level press both the Right and Left buttons at the same time. To change the dampening number, use the Left button to scroll the blinking digit to the desired number. After the selection has been made press both the Right and Left buttons at the same time to return to Run.

Indicator Calibration

The Calibration Code, or CAL code, is a mandatory input. The Indicator will not accurately display the load without the correct Calibration Code. The Calibration Code scales the signal from the Load Cell.

Indicator Calibration, continued

If the C-39 Indicator was supplied as part of a Load Weigh System, the Calibration Code will have been entered into the Indicator by the factory, however, it should be confirmed. If the Indicator is to be mated to a different Load Cell, it must be calibrated before use. Calibration can be done by entering a known Calibration Code or by lifting a known load and having the Indicator calibrate itself. Both options are discussed below.

To Look at or Change the Calibration Code

With the Indicator powered up and in the Run Mode, press both buttons at the same time to go to Setup. Scroll through the menu until the word CODE is displayed, then press the Right button. The display should look like this:

Figure 3-6 Changing the CAL Code

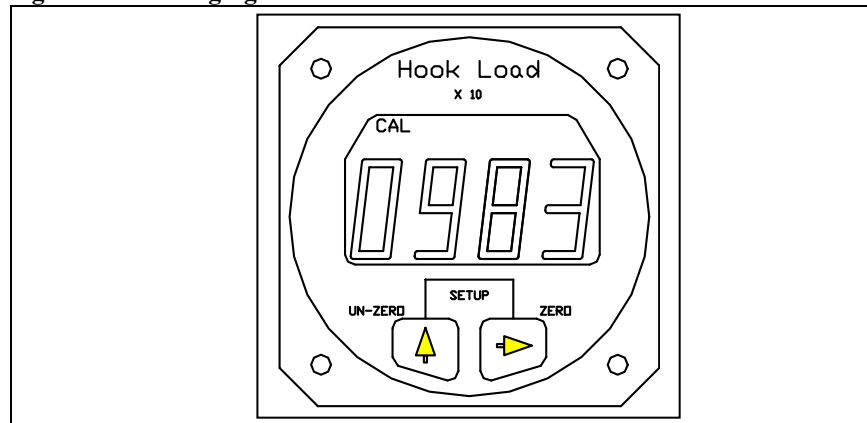

The CAL legend is turned on and the previously entered or computed Calibration Code is displayed. To return to Run without changing the CAL Code, press both the Right and Left buttons at the same time. To change the Calibration Code, use the Right button to select the digit to be changed, then use the Left button to scroll the blinking digit to the desired number. When the Calibration Code has been entered, press both the Right and Left button at the same time to return to Run.

NOTICE

Depending on the type of Load Cell, the Calibration code could be a 3 or 4 digit number. If the Calibration Code is a 3 digit number a leading zero (0) must be used. For example if a Load Cell had a CAL Code of 395 it would be entered as 0395.

If the load cell Calibration Code is not known or as a cross check, the Indicator can generate the Calibration Code. This is done by entering the weight of a known load into the Indicator LOAD routine and then lifting the load. See the section *Calibration by Lifting a Known Load*.

Installation Zero

Installation zero is a routine that matches the Indicator to the ***INSTALLED*** Load Cell. It adjusts the Indicator reading to compensate for the weight of the Cargo Hook on the Load Cell and whatever zero offset is built into the Load Cell. The Installation Zero procedure is not mandatory. If done the Indicator will read zero when the Un-Zero button is pressed and there is no weight on the Cargo Hook. If the Installation Zero is not done, the Indicator will show the weight of the Cargo Hook plus the value of the Load Cell zero offset.

To Run the Installation Zero Routine

With the Indicator powered up and in the Run Mode, press both buttons at the same time to go to Setup. Scroll through the menu until the symbol "0 in" is displayed, then press the Right button. The CAL legend will be turned on and the current weight on the Cargo Hook will be displayed and blinking. Remove any weight that is not to be zeroed out and press either button to complete the procedure and return to the Run Mode.

Calibration by Lifting a Known Weight

Calibration by lifting a known weight is a Setup routine that calculates the Calibration Code for the Load Cell attached to the Indicator. It is useful if the load cell Calibration Code is not known or as a cross check to the accuracy of a known Calibration Code. The procedure is done by entering the known weight into the Indicator and then lifting the weight. This procedure can be done in the shop or on the helicopter. The accuracy of the procedure is directly related to the weight of the known load. If for example the procedure was done with a 1,000 pound load that was assumed to weigh only 900 pounds, all subsequent lifts would be displayed 10% light.



Be sure to include the weight of everything between the Cargo Hook and the load, i.e. the cable, net, dirt, etc.

The closer the known load approaches the lifting capacity of the helicopter, the more accurate the calculated Calibration Code will be.

Calibration by Lifting a Known Weight, continued

To Run the Calibration by Lifting a Known Weight Routine

With the Indicator powered up and in the Run Mode, press both buttons at the same time to go to Setup. Scroll through the menu until the word LOAD is displayed, then press the Right button. The display should look like this:

Figure 3-7 Running CAL Routine

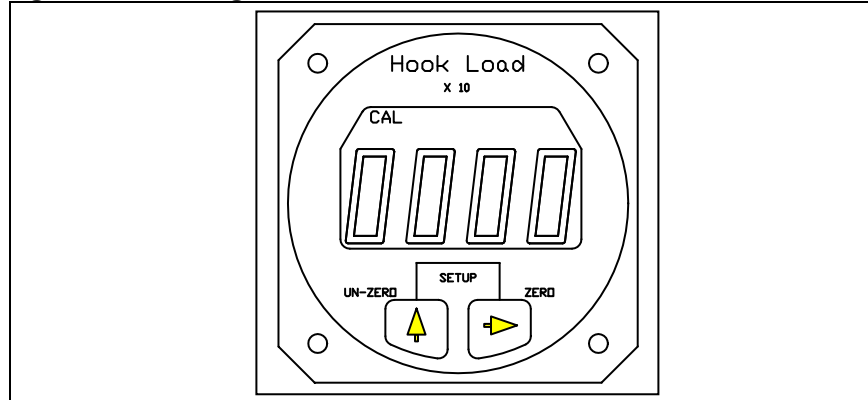

The CAL legend is turned on and the first digit is blinking. The previous load is not displayed. At this point if you wish to return to the Run Mode without changing the Calibration Code, power cycle the Indicator. At this point it is not possible to return to the Run Mode without changing the Calibration Code by using the buttons on the Indicator front panel.

To proceed with the procedure, use the Right button to select the digit to be changed, then use the Left button to scroll the blinking digit to the desired number. Note that the known weight is entered "X 10"; a 1000 pound load is entered as 100. When the known load has been entered, press both the Right and Left button at the same time. The display will look like this:

Figure 3-8 Entering Load in CAL Routine

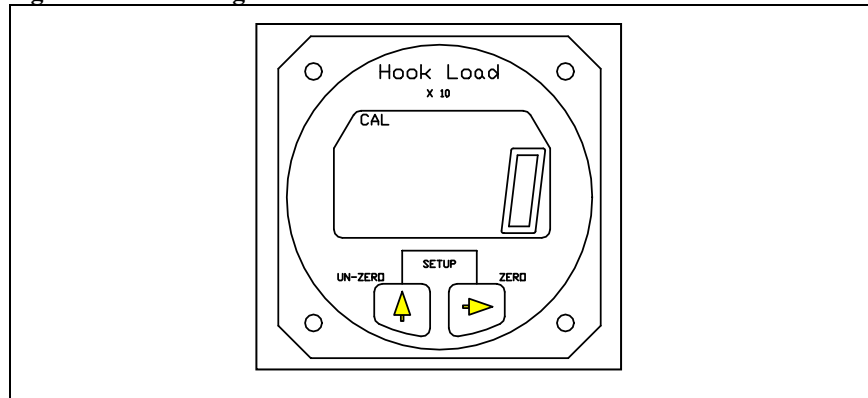

Calibration by Lifting a Known Weight, continued

The CAL legend and the digits will be blinking. Again, at this point if you wish to return to the Run Mode without changing the Calibration Code, power cycle the Indicator. It is not possible to return to the Run Mode by using the buttons on the Indicator front panel without changing the Calibration Code. If you wish to proceed, lift the known load and when it is stabilized, press either button to complete the procedure. The Indicator will display the load. This ends the procedure. The Indicator is now calibrated to the Load Cell. It is a good practice to go to the Code routine and record the new Calibration code for later reference.

Setting the Scale for a remote analog meter

The Scale routine is used when a user supplied analog meter is connected to the Indicator. It is used to match or calibrate the analog meter to the Indicator. The Indicator outputs a 0 to 5 VDC analog signal which is proportional to the Load Cell load. The Scale number tells the Indicator at what point in pounds or kilograms it should reach the 5 VDC output. If for example a 5 volt analog meter is used and its full scale reading is 10,000 pounds, the number entered into the Indicator Scale routine would be 1000 (the number is entered X 10). This number tells the Indicator that it should output the proportional 0 to 5 VDC signal between zero pounds and 10,000 pounds.

The Scale number does not affect Slave Meters, P/N 210-106-00 or 210-180-00. This number only affects user supplied instruments connected to the analog out signal.

To Look at or Change the Scale

With the Indicator powered up and in the Run Mode, press both buttons at the same time to go to Setup. Scroll through the menu until the word SCALE is displayed, then press the Right button. The display should look like this:

Figure 3-9 Changing the Scale

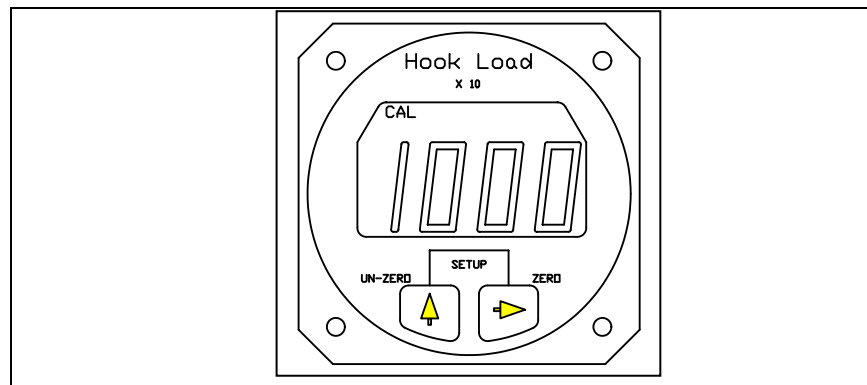

To Look at or Change the Scale, continued

The CAL legend is turned on and the previously set Scale number is displayed. To return to Run without changing the Scale, press both the Right and Left button at the same time. To change the Scale number, use the Right button to select a digit to be changed, then use the Left button to scroll the blinking digit to the desired number. When the complete Scale number has been entered, press both the Right and Left button at the same time to return to Run.

Select KG or LB Units

The units routine sets the display to read in pounds (LB) or kilograms (KG).

To look at or change the Units

With the Indicator powered up and in the Run Mode, press both buttons at the same time to go to Setup. Scroll through the menu until the word LB or KG is displayed, then press the Right button. The display should look like this:

Figure 3-10 Changing the Units

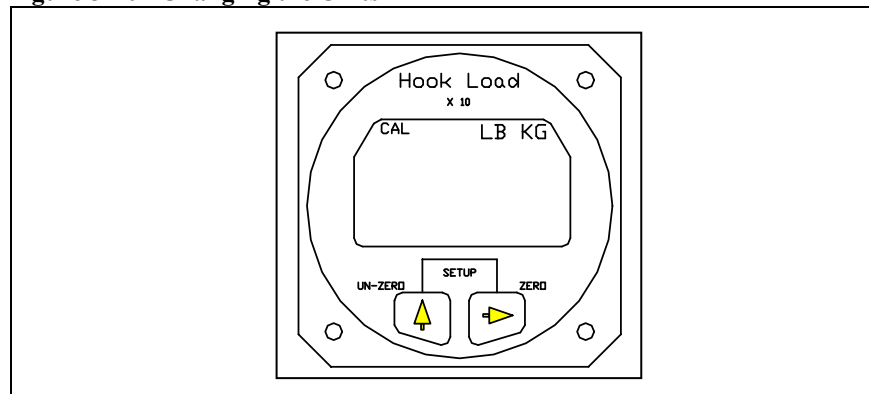

The CAL legend is turned on and the previously set unit is displayed. To return to Run without changing the units, press both the Right and Left button at the same time. To change the units press the Left button. When the selection has been made, press both the Right and Left button at the same time to return to Run.

NOTICE

The selected units are displayed when in the Run Mode.

Indicator Version

The Version routine displays the Indicator's hardware and software revision levels. Version is set at the factory and cannot be changed.

Figure 3-11 Looking at Indicator Version

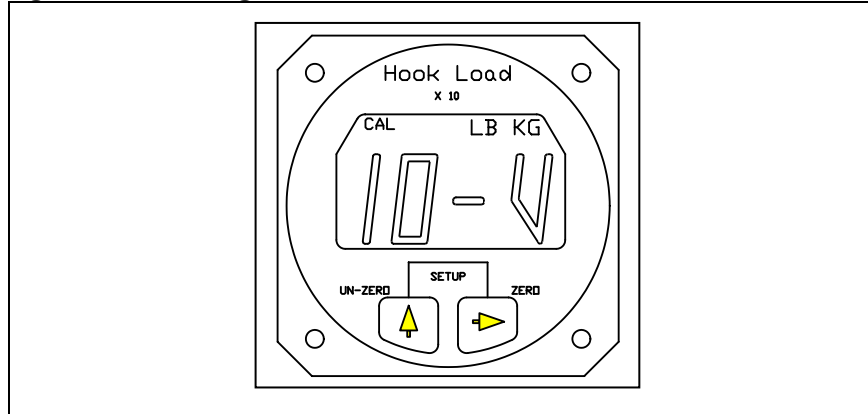

This page intentionally left blank.

Section 4

Maintenance

The following procedures are provided for the benefit of experienced aircraft maintenance facilities capable of carrying out the procedures. They must not be attempted by those lacking the necessary expertise. It is recommended that only minor repairs be attempted by anyone other than the factory.

Lubrication

Lubrication of the Load Weigh System is recommended every 500 hours of operation. To obtain maximum life under severe duty conditions such as logging or seismic work, it is recommended to lubricate the Load Cell Assembly pivot points every 200 hours. Recommended lubricants are AeroShell 17, MIL-G-21164 or Mobilgrease 28, MIL-G-81322.

Inspection

The scheduled inspection intervals noted below are maximums and are not to be exceeded. If the load weigh system is subjected to unusual circumstances, extreme environmental conditions, etc., it is the responsibility of the operator to perform the inspections more frequently to ensure proper operation.

Annually or 100 hours of external load operations, whichever comes first, inspect the load weigh system per the following instructions (see Figure 4-1 for part identification and Table 4-1 for inspection criteria).

NOTICE

*Hours of external load operations should be interpreted to be (1) anything is attached to the primary cargo hook (whether or not a useful load is being transported) and (2) the aircraft is flying. If these conditions are **NOT** met, time does **NOT** need to be tracked.*

1. Move the load cell and the cargo hook throughout their full ranges of motion and observe the load cell electrical harness to ensure that it has enough slack. The harness must not be the stops that prevent the load cell or cargo hook from moving freely in all directions.
2. Visually inspect the electrical harness strain relief at the load cell for damage.
3. Visually inspect the external load cell electrical harness for damage and chafing.
4. Visually inspect the load weigh harness connector at the belly of the helicopter for damage and security.
5. Visually inspect the load cell covers for corrosion, damage and security.
6. Visually inspect the load cell link for corrosion, damage and cracks.

Inspection continued

Every 5 years or 1000 hours of external load operations, whichever comes first, perform the following.

1. Return the Load Cell Assembly (P/N's 210-031-00, 210-031-01, 210-031-02) to the factory for inspection and calibration. The factory will inspect the condition of the load cell and perform acceptance test procedures including calibration and zero balance, repairing as necessary.
2. Inspect internal electrical harness from the load weigh indicator to the load cell for general condition, security of attachment, and chafing along the length of wire runs.
3. Inspect for security of load weigh indicator attachment.
4. Inspect load cell attachment hardware, refer to Table 4-1.

Inspection continued

Figure 4-1 Load Cell Components (Load Cell Assembly P/N 210-031-01 shown)

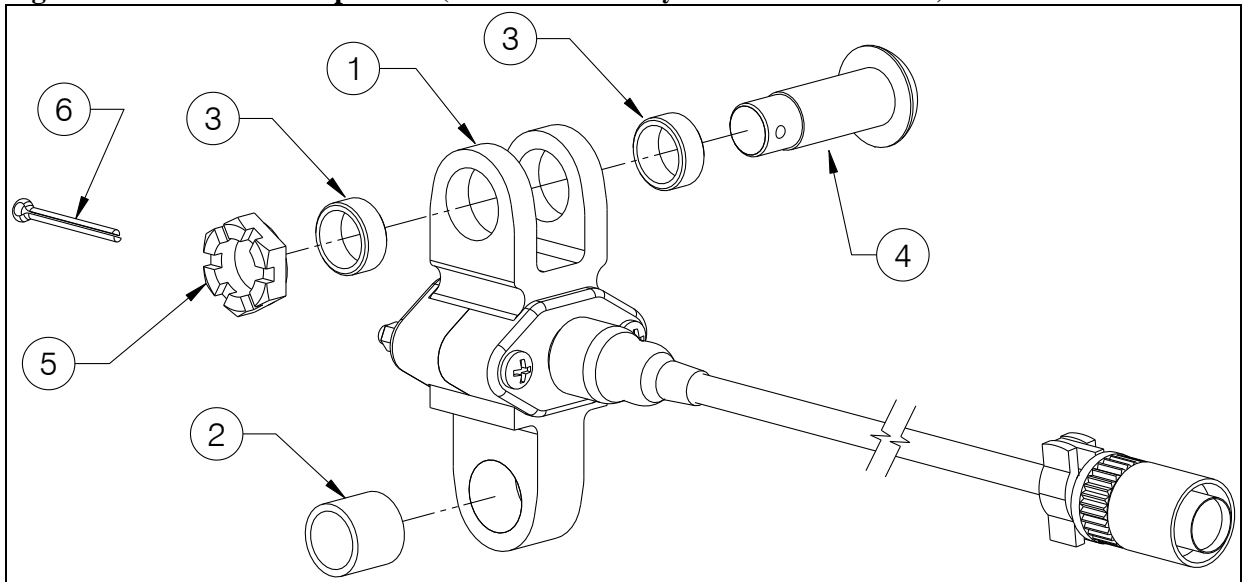

Table 4-1 Inspection Criteria

Item	Part	Inspect for:	Repair
1	Load Cell Assembly P/N 210-031-00 P/N 210-031-01 P/N 210-031-02	Dents, nicks, cracks, gouges, corrosion or scratches in the load cell link.	Repair dents, gouges, nicks, scratches and corrosion if less than .030" deep, blend out at a ratio of 20:1, length to depth, replace assembly if otherwise damaged. For P/N 210-031-00 (Cad-plated) touch up load link with zinc chromate primer. For P/N 210-031-01 and 210-031-02, load link is 15-5 stainless steel, no finish touch-up required.
		Dents, nicks, cracks, gouges, corrosion or scratches in the covers.	Repair dents, gouges, nicks, scratches and corrosion if less than .030" deep, blend out at a ratio of 20:1, length to depth. Touch up with Alodine and zinc chromate primer.
2	Bushing P/N 290-364-00 (included with 210-031-01 and -02 only)	Wear on inside diameter.	Replace bushing if inside diameter exceeds 0.520 in.
3	Bushing P/N 290-991-00 (included with 210-031-01 and -02 only)	Wear on inside diameter.	Replace bushing if inside diameter exceeds 0.520 in.
4	Bolt P/N 510-068-00	Wear on outside diameter, security of attachment.	Recommend replacement of threaded fasteners at 5 year/1000 hour interval.
5	Nut P/N 510-036-00	Security of attachment.	Recommend replacement of threaded fasteners at 5 year/1000 hour interval.
6	Cotter Pin P/N 510-067-00	Security of attachment.	Replace.

Trouble Shooting

Table 4-2 Trouble Shooting

PROBABLE CAUSE	DIFFICULTY	CORRECTIVE ACTION
Short in the system, faulty circuit breaker or switch.	Circuit breaker opens when the circuit to Load Weigh System is energized.	Repair or replace defective wiring, circuit breaker and switch.
Faulty wiring, circuit breaker or switch.	Load Weigh Indicator does not light up.	Check the power switch, circuit breaker and wiring. If this doesn't help, return the unit to the factory.
	Where Am I?	Turn the Indicator power off for a few moments. When it comes to life it will be in the Run mode.
Incorrect Calibration Code.	Displayed load is incorrect.	Insure the correct Calibration Code has been entered.
Dampening level is too small.	Displayed load is not stable.	Adjust the Dampening level to a larger number.
Dampening level is too large.	Displayed load takes too long to change the reading when the load is changed.	Adjust the Dampening level to a smaller number.
NV Ram failure, A/D or D/A circuit failure.	Do not recognize the displayed numbers on the Indicator.	Refer to <i>Error Codes</i> in section 3.
Defective load cell or damaged internal harness.	Load Weigh Indicator does not change with changing hook loads.	Check for damaged internal harness, replace load cell.

Instructions for Returning Equipment to the Factory

If an Onboard Systems product must be returned to the factory for any reason (including returns, service, repairs, overhaul, etc.) obtain an RMA number before shipping your return.



An RMA number is required for all equipment returns.

- To obtain an RMA, please use one of the listed methods.
 - Contact Technical Support by phone or e-mail (Techhelp@OnboardSystems.com).
 - Generate an RMA number at our website: <http://www.onboardsystems.com/rma.php>
- After you have obtained the RMA number, please be sure to:
 - Package the component carefully to ensure safe transit.
 - Write the RMA number on the outside of the box or on the mailing label.
 - Include the RMA number and reason for the return on your purchase or work order.
 - Include your name, address, phone and fax number and email (as applicable).
 - Return the components freight, cartage, insurance and customs prepaid to:

Onboard Systems
13915 NW 3rd Court
Vancouver, Washington 98685
USA
Phone: 360-546-3072

Section 5 Certification STC

United States of America
Department of Transportation—Federal Aviation Administration
Supplemental Type Certificate

Number SH4908NM

This certificate, issued to

**Onboard Systems
13915 NW 3rd Court
Vancouver, WA 98685**

certifies that the change in the type design for the following product with the limitations and conditions therefor as specified hereon meets the airworthiness requirements of Part 6 of the Civil Air Regulations.

Original Product—Type Certificate Number: H3WE

Make: MD Helicopters, Inc.

Model: 369D, 369E, 369F, 369FF, 369HE, 369HM,
369HS, 500N, and 600N

Description of the Type Design Change: Fabrication of Onboard Systems Model 200-034-00, 200-034-01, and 200-034-02 Load Weigh Kits in accordance with FAA-approved Onboard Systems Master Drawing List No. 155-014-00, revision 14, dated August 28, 2008, or later FAA-approved revision; and installation of these Load Weigh Kits in accordance with FAA-approved Onboard Systems Owner's Manual No. 120-017-00, Revision 8, dated August 28, 2008, or later FAA-approved revision. This modification must be inspected and maintained in accordance with Section 4 of the FAA-approved Onboard Systems Owner's Manual No. 120-017-00, Revision 8, dated August 28, 2008, or later FAA-approved revision.

Limitations and Conditions:

(See Continuation Sheet Page 3 of 3)

If the holder agrees to permit another person to use this certificate to alter the product, the holder shall give the other person written evidence of that permission.

This certificate and the supporting data which is the basis for approval shall remain in effect until surrendered, suspended, revoked, or a termination date is otherwise established by the Administrator of the Federal Aviation Administration.

Date of application: March 10, 1990
Date of issuance: March 20, 1990

Date reissued: _____
Date amended: September 14, 2007, October 3, 2008



By direction of the Administrator

A handwritten signature in black ink, appearing to be "C. J. [unclear]".

(Signature)

Acting Manager, Seattle Aircraft Certification Office

(Title)

Any alteration of this certificate is punishable by a fine of not exceeding \$1,000, or imprisonment not exceeding 3 years, or both.

This certificate may be transferred in accordance with FAR 21.47.

United States of America
 Department of Transportation—Federal Aviation Administration
Supplemental Type Certificate
Continuation Sheet
Number SH4908NM

Onboard Systems

Issued: March 20, 1990

Amended: September 14, 2007; October 3, 2008

Limitations and Conditions Continued:

Approval of this change in type design applies to only those MD Helicopter model rotorcraft listed above, which were previously equipped with an FAA-approved installation of MD Helicopters cargo hook kit and cargo hook listed in the table on page 3 of 3 or an Onboard Systems 200-187-00 or 200-264-00 cargo hook kit. This approval should not be extended to other rotorcraft of these models on which other previously approved modifications are incorporated unless it is determined by the installer that the relationship between this change and any of those other previously approved modifications, including changes in type design, will introduce no adverse effect upon the airworthiness of that helicopter. Rotorcraft modified in accordance with this STC must be operated in accordance with an FAA-approved copy of Onboard Systems Rotorcraft Flight Manual Supplement (RFMS) 121-035-00, Rev. 1, dated October 1, 2008, or later FAA-approved revision. A copy of this certificate, FAA-approved RFMS, and Maintenance Manual must be maintained as part of the permanent records of the modified rotorcraft.

Cargo Hook Kit	Helicopter Model	Cargo Hook
369H90072-501, -505, -507, -515, -519	369D	369H92105-501
369H90072-505, -517, -519	396E	Same
369H90072-505	369F	Same
369H90072-505, -511, -519	369FF	Same
369H90072-519, -523	500N	Same
369H90072-501	369HS	Same
369H90072-501	369HM	Same
369H90072-501	369HE	Same
369H90072-525, -529	600N	369H92105-503, -505

-END-

Any alteration of this certificate is punishable by a fine of not exceeding \$1,000, or imprisonment not exceeding 3 years, or both.

This certificate may be transferred in accordance with FAR 21.47.

Canadian Approval



Transport
Canada
Aviation

Transports
Canada
Aviation

Aircraft Certification Branch
620 - 800 Burrard Street
Vancouver, BC V6Z 2J8

Your file Votre référence
98-190S -700, -818
Our file Notre référence

March 4, 1999

Onboard Systems
11212 NW Saint Helens Road
Portland, OR 97231
USA

Attention: Mr. Mark Lemmon

Subject: **Familiarization of STCs SR00578SE, SH4908NM and SH1635NM**

Dear Mr. Lemmon:

This is in response to your letters dated 1 October, 1998 making application for Canadian approval of the subject STCs. Hitherto Transport Canada policy has been a process of familiarizing FAA STCs and issuing corresponding Canadian documents. However following new policy now being implemented for certain categories of FAA STCs, some will be accepted entirely on the basis of the FAA document and entered on a national index.

This letter is your verification of the acceptance of the subject STCs by Transport Canada. Should you require additional information with regards to this matter or clarification please do not hesitate to contact Mr. Paul Swan at (613) 952-4439.

Yours truly,

H. W. Wong
Regional Engineer

for
Regional Manager
Aircraft Certification

c.c. Mr. Donald L. Riggan
Manager, Seattle ACO

Canada

1/1



European Aviation Safety Agency

SUPPLEMENTAL TYPE CERTIFICATE

EASA.IM.R.S.01136 Revision 1

This Supplemental Type Certificate is issued by EASA, acting in accordance with Regulation (EC) No. 216/2008 on behalf of the European Community, its Member States and of the European third countries that participate in the activities of EASA under Article 66 of that Regulation and in accordance with Commission Regulation (EC) No. 1702/2003 to

Onboard Systems International

13915 NW 3rd Court
Vancouver
WA 98685
United States

and certifies that the change in the type design for the product listed below with the limitations and conditions specified meets the applicable Type Certification Basis and environmental protection requirements when operated within the conditions and limitations specified below:

Original Product Type Certificate Number: FAA TC H3WE
Type Certificate Holder: McDonnell Douglas
Model: MD 369D, 369E, 369F, 369FF, 369HE,
369HM, 369HS, 500N, 600N
Original STC Number: FAA STC SH4908NM

Description of Design Change:

Installation of Onboard Systems Model 200-034-00, 200-034-01, and 200-034-02 Load Weigh Kits in accordance with Onboard Systems Master Drawing List No.155-014-00, revision 14, dated August 28, 2008, or later EASA approved revision.

Associated Technical Documentation:

- Installation: Installation of the Load Weigh Kits must be in accordance with Onboard Systems Owner's Manual No. 120-017-00, Revision 8, dated August 28, 2008, or later EASA approved revision.
- Inspection and Maintenance: This modification must be inspected and maintained in accordance with Section 4 of the Onboard Systems Owner's Manual No. 120-017-00, Revision 8, dated August 28, 2008, or later EASA approved revision.
- Operation: Rotorcraft modified in accordance with STC must be operated in accordance with Onboard Systems Rotorcraft Flight Manual Supplement (RFMS) 121-035-00, Rev. 1, dated 1 October 2008, or later EASA approved revision.

Limitations and Conditions:

1. Prior to installation of this modification the installer must determine that the interrelationship between this modification and any other previously installed modification will introduce no adverse effect upon the airworthiness of the product. The installation of this modification by third persons is subject to written permission of the approval holder and holding and disposal of the approved appropriate documentation.
2. Approval of this change in type design applies to only those MD Helicopter model rotorcraft listed above, which were previously equipped with an FAA approved installation of MD Helicopter cargo hook kit and cargo hook listed in the table or an Onboard Systems 200-187-00 or 200-264-00 cargo hook kit.

EASA STC continued



European Aviation Safety Agency

Cargo Hook Kit	Helicopter Model	Cargo Hook
369H90072-501, -505, -507, -515, -519	369D	369H92105-501
369H90072-505, -517, -519	369E	369H92105-501
369H90072-505	369F	369H92105-501
369H90072-505, -511, -519	369FF	369H92105-501
369H90072-519, -523	500N	369H92105-501
369H90072-501	369HE	369H92105-501
369H90072-501	369HM	369H92105-501
369H90072-501	369HS	369H92105-501
369H90072-525, -529	600N	369H92105-503, -505

This Certificate shall remain valid unless otherwise surrendered or revoked.

For the European Aviation Safety Agency,

Date of issue: 15 July 2009

Massimo MAZZOLETTI
Certification Manager

STC – EASA.IM.R.S.01136 Revision 1 – Onboard Systems International