

**PLEASE CHECK WEB SITE AT WWW.ONBOARDSYSTEMS.COM FOR
THE LATEST REVISION OF THIS MANUAL**

Cargo Hook Kit

for the

Airbus Helicopters AS350

Kit Part Number 200-190-00

STC SR00439SE

Owner's Manual

Owner's Manual Number 120-050-00

Revision 11

August 29, 2016



13915 NW 3rd Court Vancouver Washington 98685 USA
Phone: 360-546-3072 Fax: 360-546-3073 Toll Free: 800-275-0883
www.OnboardSystems.com

This page intentionally left blank.

RECORD OF REVISIONS

<i>Revision</i>	<i>Date</i>	<i>Page(s)</i>	<i>Reason for Revision</i>
3	6-12-00	4-*	Removed maintenance instructions to a separate document. 122-001-00.
4	6-6-01	3-5 RFMS Page 5	Replaced hook picture to show new cover and S/N plate.
5	7/27/02	1-1 and 2-2	Added 290-744-00 optional manual release adapter.
6	9/17/02	Title, 4-3	Factory address change.
7	03/14/06	Title, TOC, 1-1, & Section 2	Removed references to AS 355 aircraft.
8	08/30/06	3-1, Section 4	Replace reference to table in section 4 with reference to cargo hook service manual on page 3-1. Updated Cargo Hook Maintenance section to refer to cargo hook service manual.
9	02/12/07	1-1, 2-1, 2-3	Changed cargo hook part no. from 528-010-00 to 528-010-04 (ref. service bulletin 159-017-00). Corrected washer part no. in Figure 2-1 and 2-3 from 510-144-00 to 510-183-00.
10	09/25/07	Section 1, 2-2, 2-3, 2-5, 2-6, Section 3	Added warnings, cautions and notes explanation to general information section. Updated warnings, cautions and notes throughout.
11	08/29/16	Section 1, 2, and 3	Added optional connector P/N 230-077-00. Updated format of safety labels throughout.

Register Your Products for Automatic Notifications

Onboard Systems offers a free notification service via fax or email for product alerts and documentation updates. By registering your Onboard Systems products at our website, we will be able to contact you if a service bulletin is issued, or if the documentation is updated.

You can choose to receive notices on an immediate, weekly, or monthly schedule via fax, email or both methods. There is no charge for this service. Please visit our website at www.onboardsystems.com/notify.php to get started.

This page intentionally left blank.

CONTENTS

Section 1 **General Information**

Introduction, 1-1
Safety Labels, 1-1
Bill of Materials, 1-2
Inspection, 1-2
Cargo Hook Specifications, 1-2
Theory of Operation, 1-3

Section 2 **Installation Instructions**

AS 350 Sling Cargo Hook Removal, 2-1
AS 350 Sling Cargo Hook Installation, 2-1
AS 350 Swing Cargo Hook Removal, 2-3
AS 350 Swing Cargo Hook Installation, 2-3
Installation Instructions, 2-6
Installation Check-out, 2-7
Weight, 2-7
Paper Work, 2-7

Section 3 **Operation Instructions**

Operating Procedures, 3-1
Cargo Hook Rigging, 3-2
Un-Commanded Release Due to Too Large of a Load Ring, 3-4
Load Hang-Up Due to Small Load Ring or Multiple Load Rings, 3-5
Un-Commanded Release Due to Nylon Straps, 3-6
Un-Commanded Release Due to Cable or Rope Type Straps, 3-7

Section 4 **Maintenance**

Instructions for Returning a System to the Factory, 4-1

Section 5 **Certification**

FAA STC, 5-1
Canadian STC, 5-2
Rotorcraft Flight Manual Supplement

This page intentionally left blank.

Section 1

General Information

Introduction

The 200-190-00 Cargo Hook Kit is approved as a replacement for the following Cargo Hooks on the Airbus Helicopters AS350B, AS350B1, AS350B2, AS350BA, and AS350D.

Table 1-1 Cargo Hooks

P/N	Manufacturer
17149-1	Breeze-Eastern
14027-4	Breeze-Eastern
S1609-3	Siren
S1609-5	Siren
S1609-6	Siren

Safety Labels

The following definitions apply to Safety Labels used in this manual.



Indicates a hazardous situation which, if not avoided, will result in death or serious injury.



Indicates a hazardous situation which, if not avoided, could result in death or serious injury.



Indicates a hazardous situation which, if not avoided, could result in minor or moderate injury.



Draws the reader's attention to important or unusual information not directly related to safety.



Used to address practices not related to personal injury.

Bill of Materials

The following items are included with the AS350 Cargo Hook Kit, P/N 200-190-00, if shortages are found contact the company from whom the system was purchased.

Table 1-2 Kit Bill of Materials

Part No.	Description	Quantity
528-010-04	Cargo Hook	1
290-403-00	Hook to Manual Release Adapter	1
290-744-00	HK Manual Release Adapter	1
510-252-00	Jam Nut	1
410-131-00*	Electrical Connector	1
512-010-00	Adel Clamp	2
120-050-00	Owner's Manual	1
122-001-00	Cargo Hook Service Manual	1

*Optional Connector P/N 230-077-00 can be used in place of P/N 410-131-00. It provides a lower profile for use on the Swing installation.

Inspection

Inspect the kit items for evidence of damage, corrosion and security of lock wire and fasteners. If damage is evident, do not use the items until they are repaired.

Cargo Hook Specifications

Table 1-3 Specifications

Design load	3,500 lb. (1,587 kg.)
Design ultimate strength	15,750 lb. (7,143 kg.)
Electrical release capacity	8,750 lb. (3,968 kg.)
Mechanical release capacity	8,750 lb. (3,968 kg.)
Force required for mechanical release at 3,500 lb.	8 lb. Max. (.400" travel)
Electrical requirements	22-28 VDC 9 amps
Minimum release load	7 pounds
Unit weight	3 pounds (1.36 kg.)
Mating electrical connector	PC06A8-2S SR



Load capacities given are for the equipment described only. Loading limits for your particular helicopter model still apply. Consult your flight manual.

Theory of Operation

The primary elements of the Cargo Hook are the load beam, the internal mechanism, and a DC solenoid. The load beam supports the load and is latched through the internal mechanism. The DC solenoid and an external manual release cable provide the means for unlatching the load beam.

The load beam is normally returned to its closed position after release of the load by a spring in the internal mechanism. In the closed position, a latch engages the load beam and latches it in this position. The load is attached to the load beam by passing the cargo sling ring into the throat of the load beam past a spring-loaded keeper, which secures the load.

To release the load, the latch is disengaged from the load beam. With the latch disengaged, the weight of the load causes the load beam to swing to its open position, and the cargo sling slides off the load beam. A spring in the internal mechanism then drives the load beam back to its closed and latched position.

A load release can be initiated by three different methods. Normal release is achieved by pilot actuation of a push-button switch in the cockpit. When the push-button switch is pressed, it energizes the DC solenoid in the Cargo Hook, and the solenoid opens the latch in the internal mechanism. In an emergency, release can be achieved by operating a mechanical release lever. A manual release cable attached to the lever operates the internal mechanism of the Cargo Hook to unlatch the load beam. The load can also be released by the actuation of a lever located on the side of the Cargo Hook.

This page intentionally left blank.

Section 2

Installation Instructions

These procedures are provided for the benefit of experienced aircraft maintenance facilities capable of carrying out the procedures. They must not be attempted by those lacking the necessary expertise.

AS 350 Sling Cargo Hook Removal

Remove the old Cargo Hook from the aircraft by disconnecting the hook from the load link (gauge shackle) and the manual and electrical release cables.

AS 350 Sling Cargo Hook Installation

Inspect the load link, universal joint and attaching hardware to insure that they are in serviceable condition.

Attach the new Cargo Hook to the load link using the hardware supplied, as illustrated below. The cargo hook load beam should point forward.

Figure 2-1 Sling Assembly Installation

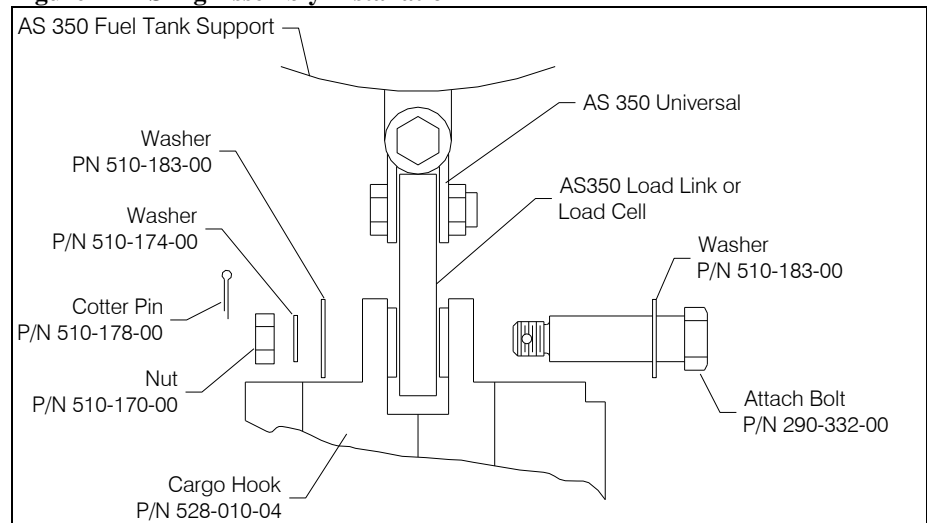

AS 350 Sling Cargo Hook Installation, continued

Remove the manual release cover from the new Cargo Hook. When Airbus Helicopters aft release cable AS22-08 is installed, manual release adapter P/N 290-744-00 will provide the best release cable free play adjustment. For other cable configurations manual release cable adapter P/N 290-403-00 will provide best adjustment.

Thread appropriate adapter and jam nut P/N 510-252-00 into the new Cargo Hook.

Connect the manual release cable to the Adapter.

Place the cable ball end fitting into the hook manual release fork fitting as illustrated in Figure 2-2. Adjust the Adapter to give .125" of free play with the manual release lever in the non-release position.

Tighten the jam nut against the hook and safety wire the manual release cable nut to the jam nut and the cover screw.

Figure 2-2 Manual Release Cable Rig

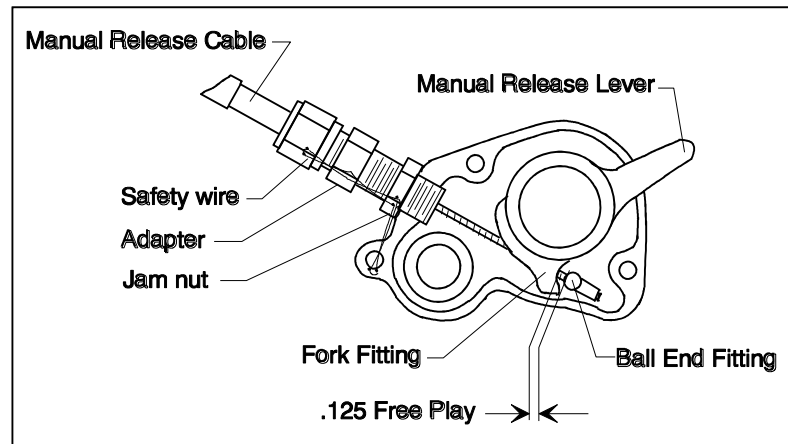

Connect the cargo hook electrical release cable connector to the Cargo Hook. Listed below is the pin out for the cargo hook connector. Safety wire the connector.

Table 2-1 Cargo Hook Connector

<i>Pin</i>	<i>Function</i>
A	Ground
B	Power

AS 350 Sling Cargo Hook Installation, continued

CAUTION

The Cargo Hook is equipped with a suppression diode that will be damaged if the Cargo Hook electrical connections are reversed. Do not attach the electrical connector until the polarity of the aircraft connector is determined to be compatible with the Cargo Hook connector listed in Table 2-1.

AS 350 Swing Cargo Hook Removal

Remove the old Cargo Hook from the aircraft by disconnecting the hook from the load link (gauge shackle) and the manual and electrical release cables.

AS 350 Swing Cargo Hook Installation

Inspect the swing assembly components to insure that they are in serviceable condition.

Attach the new Cargo Hook to the load link using the hardware supplied, as illustrated below. The cargo hook load beam should point forward.

Figure 2-3 Swing Assembly Installation

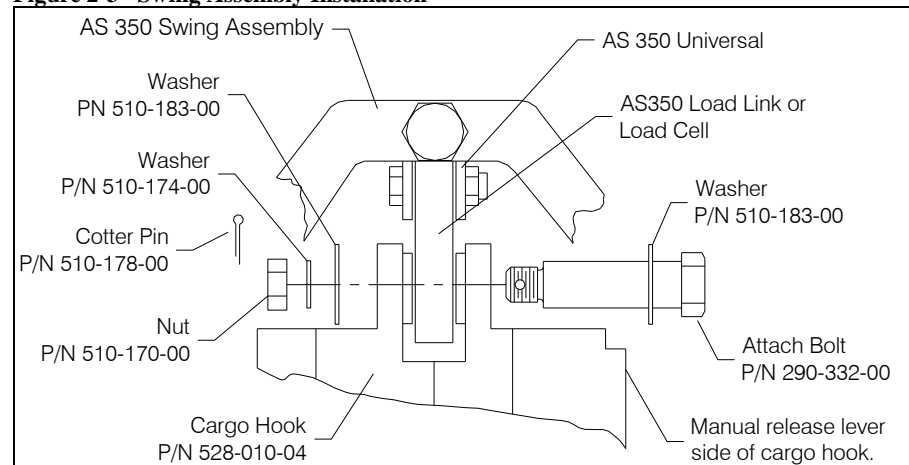

AS 350 Swing Cargo Hook Installation, continued

Remove the manual release cover from the new Cargo Hook.

Thread the Hook to Manual Release Adapter, P/N 290-403-00 into the new Cargo Hook.

Connect the manual release cable to the Adapter. Place the cable ball end fitting into the hook manual release fork fitting as illustrated in Figure 2-4.

Adjust the adapter to give .125" of free play with the manual release lever in the non-release position.

Tighten the jam nut against the hook and safety wire the manual release cable nut to the jam nut and the cover screw.

If a Siren cargo hook is to be replaced it will be necessary to replace the manual release cable with an Airbus Helicopters P/N 704A31-813-010 (Siren P/N AS22-18) or another approved cable. This is the cable used with the Breeze-Eastern Cargo Hook.

Secure the adel clamps to the lower screws on the cargo hook manual release and electrical release sides as illustrated. Safety wire the screws.

Figure 2-4 Manual Release Cable Rigging

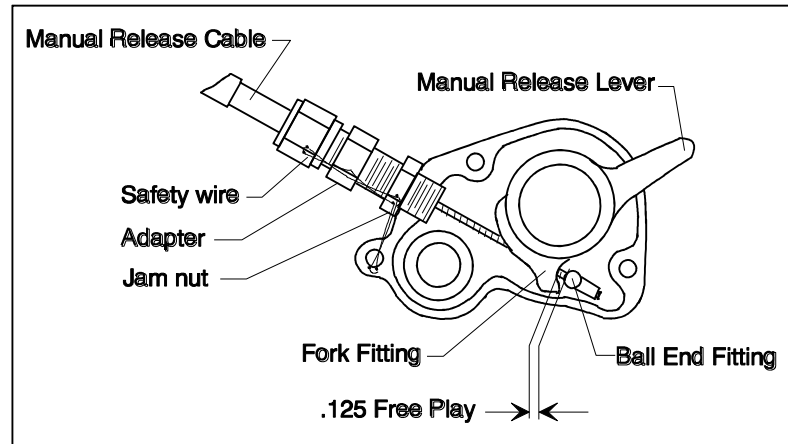
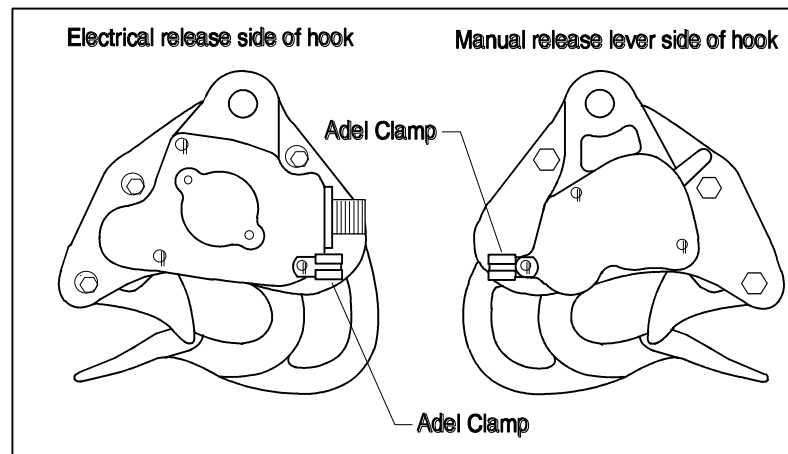

Figure 2-5 Adel Clamp Installation



AS 350 Swing Cargo Hook Installation, continued

If the hook removed was manufactured by Siren or if it was a Breeze-Eastern 14027-4 it will be necessary to replace the connector on the electrical release cable with the one supplied with the Cargo Hook Kit. If preferred a short adapter cable can be fabricated to connect the electrical release cable to the hook. Listed below is the pin out for the cargo hook connector.

Connect the cargo hook electrical release cable connector to the Cargo Hook and secure with safety wire.

Table 2-2 Cargo Hook Connector

<i>Pin</i>	<i>Function</i>
A	Ground
B	Power

CAUTION

The Cargo Hook is equipped with a suppression diode that will be damaged if the Cargo Hook electrical connections are reversed. Do not attach the electrical connector until the polarity of the aircraft connector is determined to be compatible with the Cargo Hook connector listed in Table 2-2.

Attach the two elastic cords that were previously removed to the adel clamps that are supplied with the Cargo Hook Kit. Refer to the illustration below.

Figure 2-6 Swing Assembly Overview

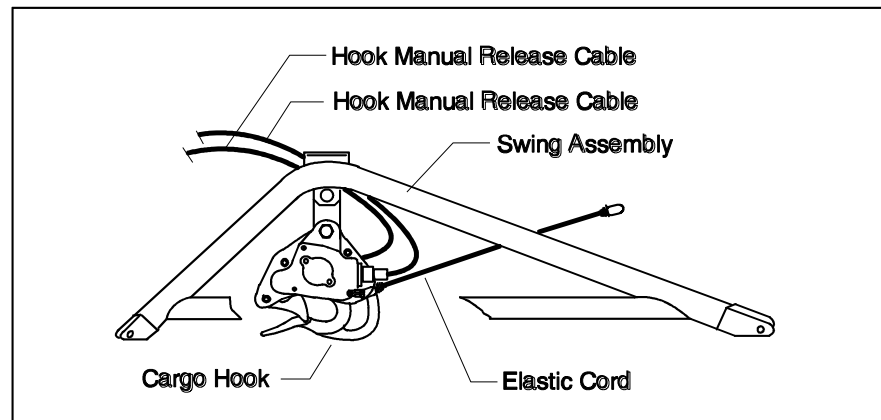

Installation Instructions



Un-commanded cargo hook release will happen if the manual release cable is improperly restrained. The cable must not be the stops that prevent the Cargo Hook from swinging freely in all directions. If the Cargo Hook loads cause the hook to strain against the manual release cable the swaged end of the cable may separate allowing the inner cable to activate the cargo hook manual release mechanism. The result is an un-commanded release. Ensure that no combination of cyclic stick or cargo hook position is restrained by the manual release cable.

Figure 2-7 Un-Commanded Release From Incorrectly Secured Cable

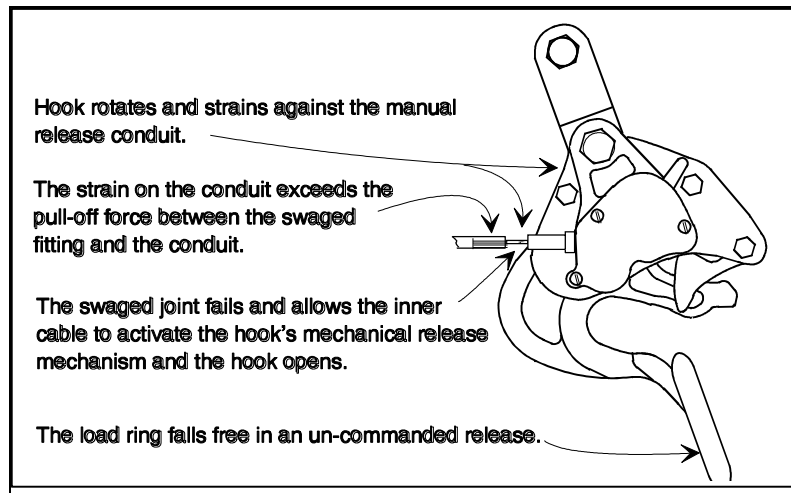

Installation Check-Out

After installation of the Cargo Hook, perform the following functional checks.

1. Swing the installed Cargo Hook to ensure that the manual release cable assembly and the electrical release cable have enough slack to allow full swing of the suspension assembly without straining or damaging the cables. The cables must not be the stops that prevent the Cargo Hook from swinging freely in all directions. It may be necessary to install bumper pads on the Swing to prevent the release cables from being damaged.
2. Apply 10-20 pounds to the cargo hook load beam and pull the handle operated cargo hook mechanical release, the Cargo Hook must release.
3. Close the cargo hook release circuit breaker and position the battery switch to the ON position. Apply 10-20 pounds to the cargo hook load beam and depress the cargo hook electrical release button, the Cargo Hook must release.
4. See the Airbus Helicopters service instructions for your specific helicopter model for additional installation instructions.

Weight

The weight of the Cargo Hook is listed in Table 2-4.

Table 2-4 Component Weights

Item	Weight lbs (kgs)
Cargo Hook	3.0 (1.36)

Paper Work

Remove the Flight Manual Supplement from the back of this manual and place it into Rotorcraft Flight Manual. In the US, fill in FAA form 337 for the initial installation. This procedure may vary in different countries. Make the appropriate aircraft log book entry.

This page intentionally left blank.

Section 3

Operation Instructions

Operating Procedures

Prior to a flight involving external load operations perform the following.

1. Ensure that the Cargo Hook has been properly installed and that the manual and electrical release cables do not limit the movement of the hook.
2. Be completely familiar with this manual, particularly the Cargo Hook rigging section.
3. Be completely familiar with all Airbus Helicopters Cargo Hook operating instructions.
4. Activate the electrical system and press the cargo hook release button to ensure the cargo hook electrical release is operating correctly. The mechanism should operate smoothly and the Cargo Hook should re-latch after release. If the hook does not re-latch do not use the unit until the difficulty is resolved.

CAUTION

The release solenoid is intended to be energized only intermittently. Depressing the electrical release button continuously in excess of 20 sec. will cause the release solenoid to overheat, possibly causing permanent damage.

5. Activate the manual release lever to test the cargo hook manual release mechanism. The mechanism should operate smoothly and the Cargo Hook must relatch after release. If the hook does not relatch do not use the unit until the difficulty is resolved.

See the Cargo Hook Component Maintenance Manual 122-001-00 and the aircraft's service instructions that cover the original Cargo Hook installation for additional instructions.

Cargo Hook Rigging

Extreme care must be exercised in rigging a load to the Cargo Hook. If the load ring is too big it may work its way around the end of the load beam and be supported for a time on the keeper and then fall free. If the load ring is too small it may jam itself against the load beam during an attempted release. The following illustrations show recommended configurations and potential difficulties that must be avoided.



The examples shown are not intended to represent all problem possibilities. It is the responsibility of the operator to assure the hook will function properly with the rigging.

Cargo Hook Rigging, continued

Figure 3-1 Examples of Correct and Incorrect Cargo Hook Rigging

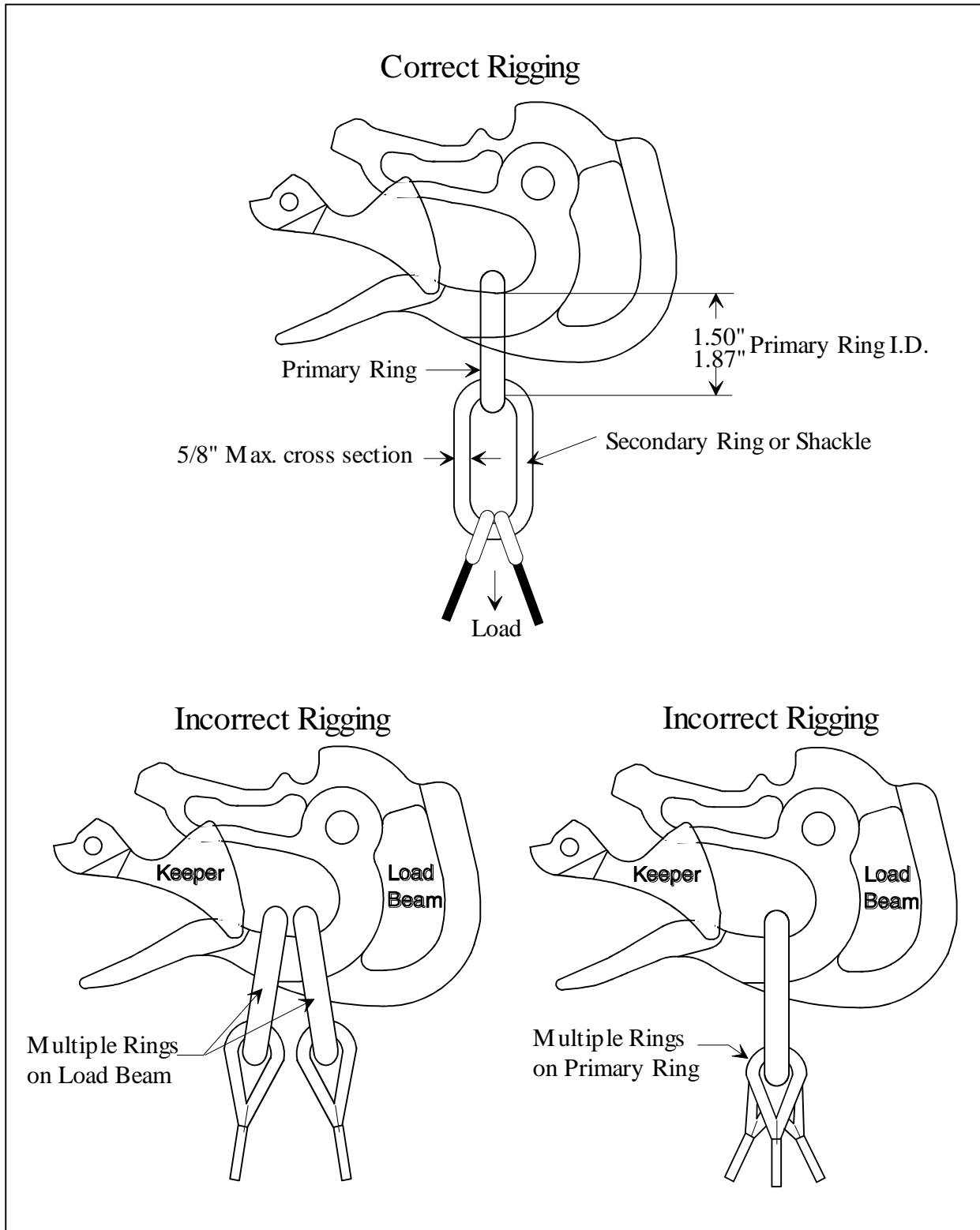

Un-Commanded Release Due to Too Large of a Load Ring



Load rings that are too large will cause an un-commanded release. The ring will flip over the end of the load beam and flip the keeper up and then fall free. Only correctly sized load rings must be used. See examples below.

Figure 3-2 Un-Commanded Release Due to Too Large of a Load Ring

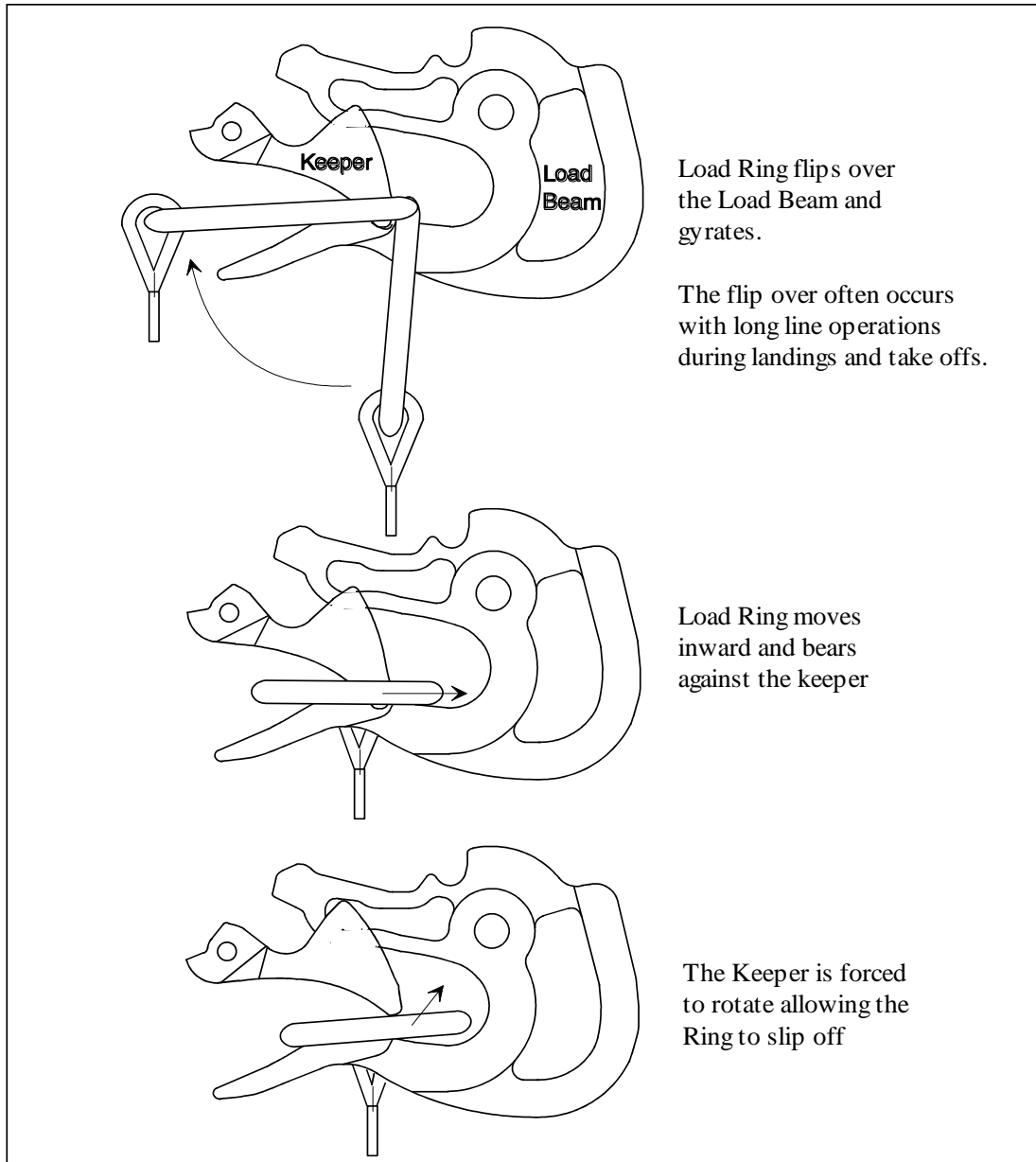

Load Hang-Up Due to Too Small of a Load Ring or Multiple Load Rings



Load rings that are too small or multiple load rings will hang on the load beam when the load is released. Only correctly sized load rings must be used. See examples below.

Figure 3-3 Load Hang-Up Due to Too Small of a Load Ring or Multiple Load Rings

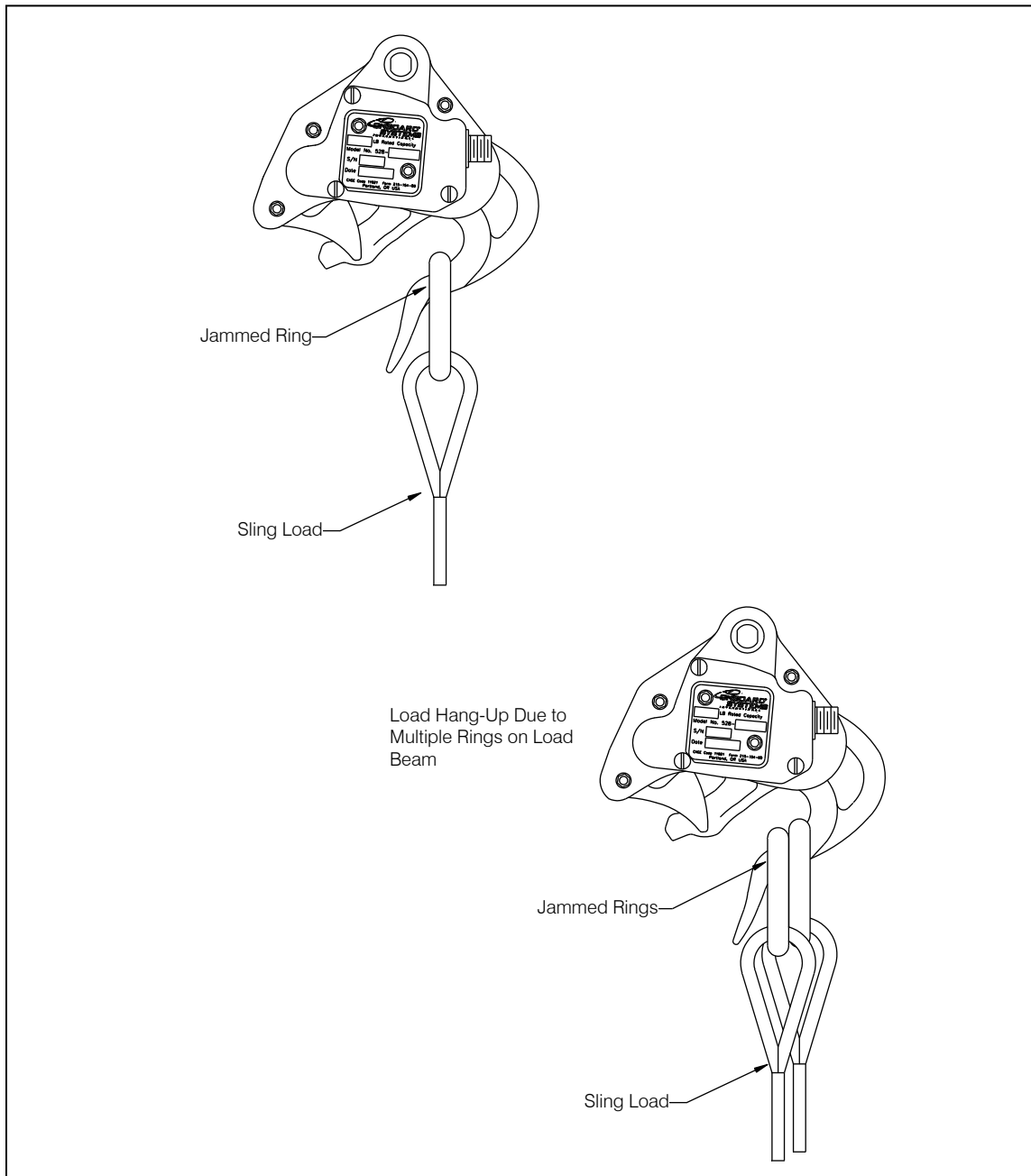

Un-Commanded Release Due to Nylon Type Straps



Nylon type straps (or similar material) must not be used directly on the cargo hook load beam as they have a tendency to creep under the keeper and fall free. If nylon straps must be used they should be first attached to a correctly sized primary ring. Only the primary ring should be in contact with the cargo hook load beam. See examples below.

Figure 3-4 Un-Commanded Release Due to Nylon Type Straps

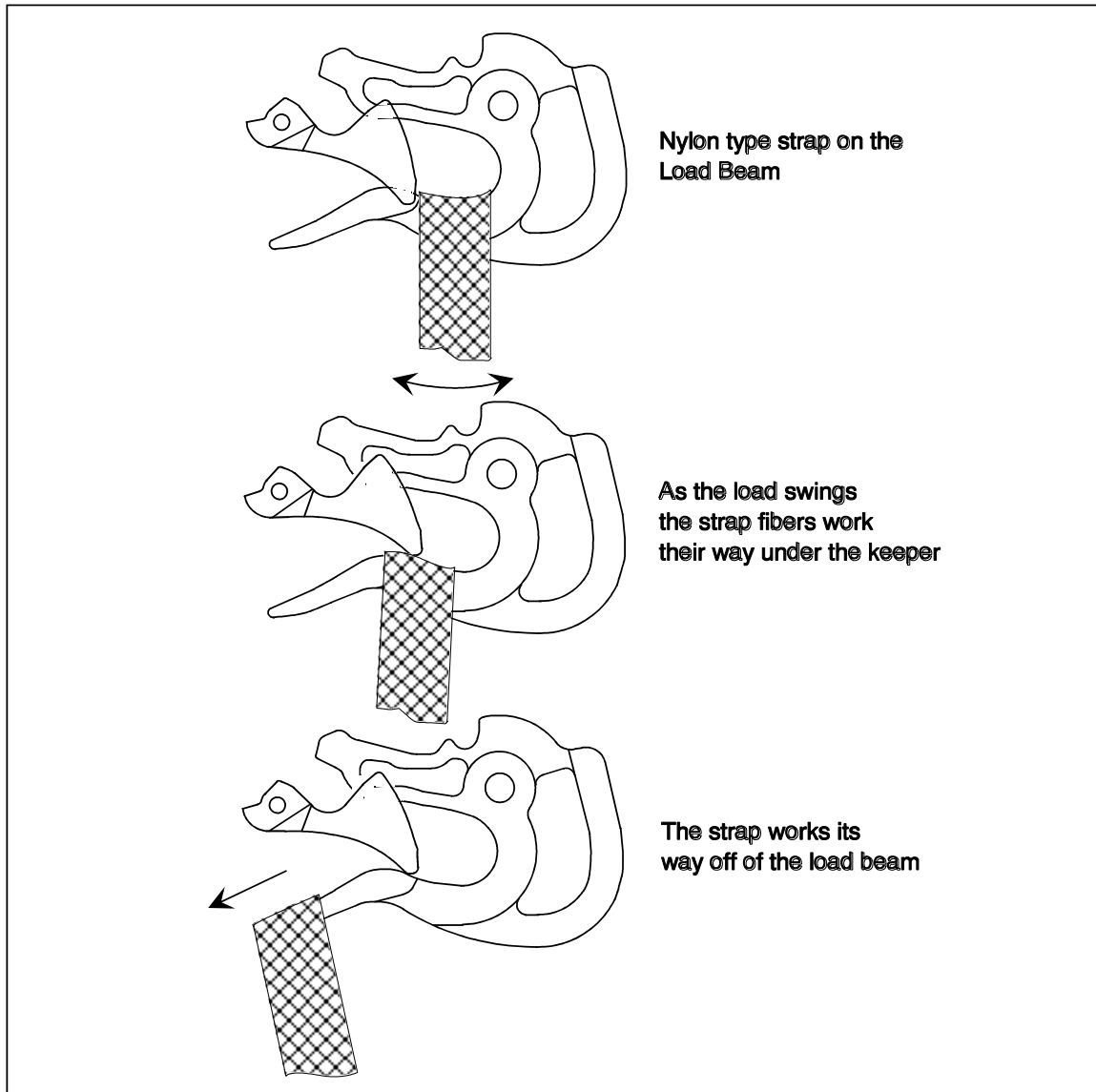

Un-Commanded Release Due to Cable or Rope Type Straps



Cable or rope type straps must not be used directly on the cargo hook load beam. Their braided eyes will work around the end of the load beam and fall free. If cable or rope is used they should be first attached to a correctly sized primary ring. Only the primary ring should be in contact with the cargo hook load beam. See examples below.

Figure 3-5 Un-Commanded Release Due to Cable or Rope Type Straps

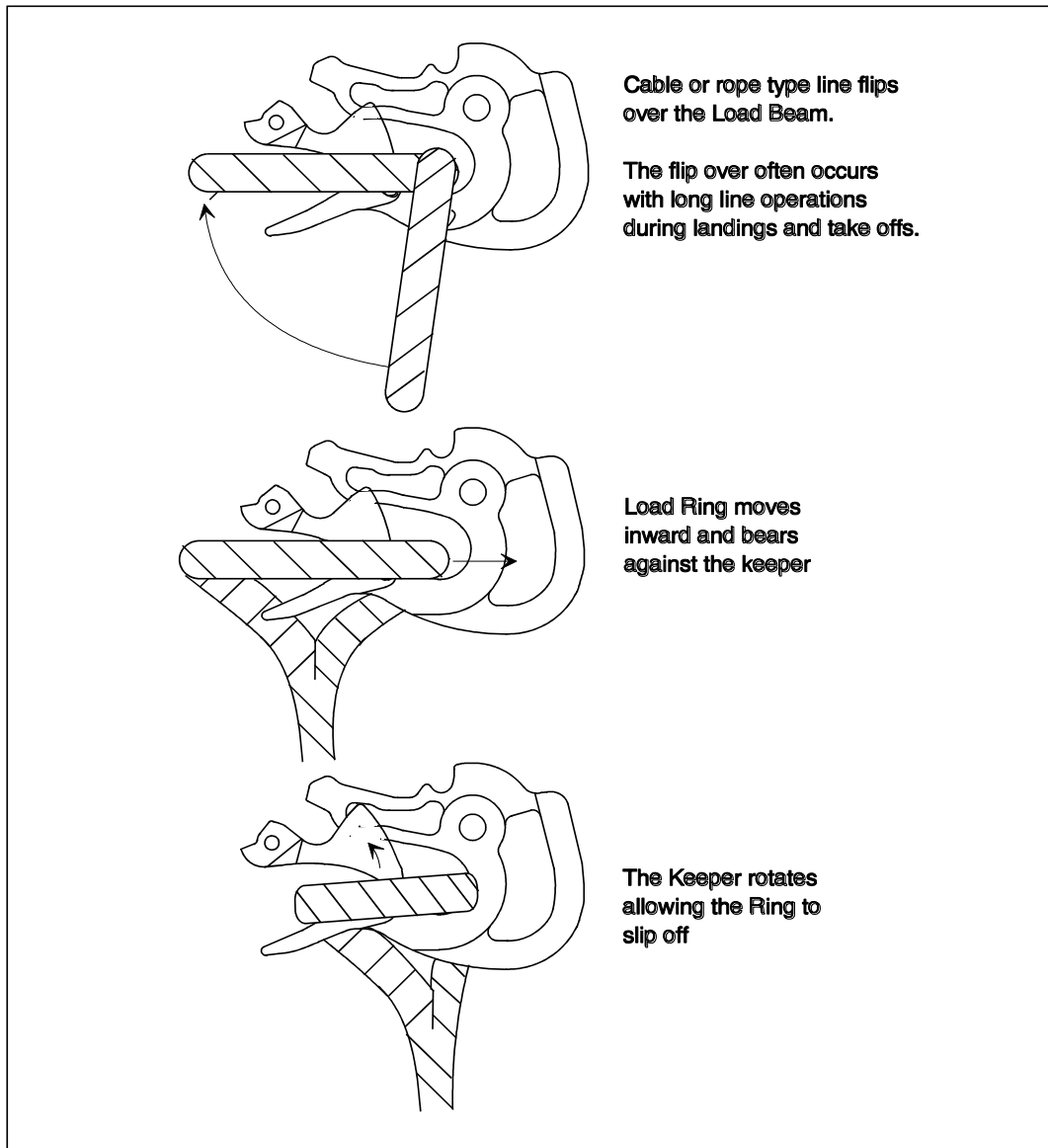

This page intentionally left blank.

Section 4

Maintenance

Refer to Component Maintenance Manual 122-001-00 for detailed maintenance information for the Cargo Hook.

Instructions for Returning Equipment to the Factory

If an Onboard Systems product must be returned to the factory for any reason (including returns, service, repairs, overhaul, etc.) obtain an RMA number before shipping your return.



An RMA number is required for all equipment returns.

- To obtain an RMA, please use one of the listed methods.
 - Contact Technical Support by phone or e-mail (Techhelp@OnboardSystems.com).
 - Generate an RMA number at our website: <http://www.onboardsystems.com/rma.php>
- After you have obtained the RMA number, please be sure to:
 - Package the component carefully to ensure safe transit.
 - Write the RMA number on the outside of the box or on the mailing label.
 - Include the RMA number and reason for the return on your purchase or work order.
 - Include your name, address, phone and fax number and email (as applicable).
 - Return the components freight, cartage, insurance and customs prepaid to:

Onboard Systems
13915 NW 3rd Court
Vancouver, Washington 98685
USA
Phone: 360-546-3072

This page intentionally left blank.

Section 5 Certification

United States of America

Department of Transportation—Federal Aviation Administration

FAA STC Supplemental Type Certificate

Number SR00439SE

This certificate, issued to **Onboard Systems
13915 NW 3rd Court
Vancouver, WA 98685**

certifies that the change in the type design for the following product with the limitations and conditions therefor as specified hereon meets the airworthiness requirements of Part 6 of the Civil Air Regulations.

Original Product—Type Certificate Number: H9EU
Make: Eurocopter France
Model: AS-350B, AS-350B1, AS350B2, AS350BA and AS-350D

Description of the Type Design Change: Fabrication of Onboard Systems Model 200-190-00 Cargo Hook Kit in accordance with FAA Approved Onboard Systems Master Drawing List No. 155-033-00, Revision 4, dated October 31, 2000, or later FAA approved revision; and installation of these systems in accordance with FAA approved Onboard Systems Owner's Manual No. 120-050-00, Revision 3, dated June 12, 2000, or later FAA approved revision. Inspect cargo hook kit in accordance with Onboard Systems Owner's Manual No. 120-050-00, Revision 3, dated June 12, 2000, and Onboard Service Manual No. 122-001-00, Revision 0, dated June 13, 2000, or later FAA approved revision.

Limitations and Conditions: Approval of this change in type design applies only to those Eurocopter model rotorcraft listed above, which are equipped with an FAA approved installation of Breeze Eastern P/N 17149-1 or 14027-4 or Siren P/N S1609-3, -5 and -6 cargo hooks or those modified by installation of an Onboard Systems load weigh system per STC SH1262NW. This approval should not be extended to rotorcraft of these models on which other previously approved modifications are incorporated unless it is determined by the installer that the relationship between this change and any of those other previously approved modifications, including changes in type design, will introduce no adverse effect upon the airworthiness of that rotorcraft. Rotorcraft equipped with the 200-190-00 cargo hook kit must be operated in accordance with FAA approved Rotorcraft Flight Manual Supplement (RFMS) No. 120-050-00, dated December 2, 1998, or later FAA approved revision. A copy of this Certificate and FAA approved RFMS must be maintained as part of the permanent records for the modified rotorcraft.

If the holder agrees to permit another person to use this certificate to alter the product, the holder shall give the other person written evidence of that permission.

This certificate and the supporting data which is the basis for approval shall remain in effect until surrendered, suspended, revoked, or a termination date is otherwise established by the Administrator of the Federal Aviation Administration.

Date of application: March 29, 1997

Date reissued:

Date of issuance: May 19, 1997

Date amended: May 4, 2001; January 13, 2003



By direction of the Administrator

Richard J. [Signature]
(Signature)

Acting Manager, Seattle Aircraft
Certification Office

(Title)

Any alteration of this certificate is punishable by a fine of not exceeding \$1,000, or imprisonment not exceeding 3 years, or both.

This certificate may be transferred in accordance with FAR 21.47.

FAA FORM 8110-2(10-68)

Canadian STC



Transport Canada Transports Canada

Department of Transport

Supplemental Type Certificate

This approval is issued to:

Onboard Systems
11212 NW St. Helens Road
Portland, OR
USA 97231

Number: SH98-8

Issue No.: 1

Approval Date: February 6, 1998

Issue Date: February 9, 1998

Responsible Office:

Pacific

Aircraft/Engine Type or Model:

Eurocopter France AS350B, AS350B1, AS350B2, AS350BA
and AS350D

Canadian Type Certificate or Equivalent:

H-83

Description of Type Design Change:

Installation of Onboard Systems Cargo Hook Kit per FAA
STC SR00439SE

**Installation/Operating Data,
Required Equipment and Limitations:**

Fabrication of Onboard Systems Model 200-190-00 Cargo Hook
Kit in accordance with FAA approved Onboard Systems
Master Drawing List No. 155-033-00, dated January 10, 1997 * ;
and, **Installation** of this system in accordance with FAA
approved Onboard Systems Owner Manual No. 120-050-00,
dated December 10, 1996 * . **Inspect** cargo hook kit in
accordance with Section 4 of Onboard Systems Owners
Manual No. 120-050-00, dated December 10, 1996 * .

(* or later FAA approved revisions)

— See Continuation Sheet —

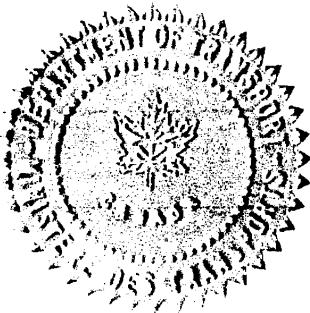

Conditions: This approval is only applicable to the type/model of aeronautical product specified therein. Prior to incorporating this modification, the installer shall establish that the interrelationship between this change and any other modification(s) incorporated will not adversely affect the airworthiness of the modified product.

L. B. Samoil
Regional Airworthiness Engineer
For Minister of Transport

Canada

Department of Transport

Supplemental Type Certificate

(Continuation Sheet)

Number: SH98-8

Issue No.: 1

Approval Date: February 6, 1998

Issue Date: February 9, 1998

Notice:

This Addendum shall remain part of the Supplemental Type Certificate referred therein.

Limitations and Conditions:

1. Approval of this change in type design applies to only those Eurocopter model rotorcraft listed on the front page, which are equipped with an FAA approved installation of Breeze Eastern P/N 17149-1 or 14027-4 or Siren P/N S1609-3, -5 and -6 cargo hooks or those modified by installation of an Onboard Systems load weigh system per STA SH85-8.
2. This installation should not be incorporated in any rotorcraft on which other previously approved modifications are incorporated unless it is determined that the interrelationship between this installation and any previously approved modifications, including changes in type design, will not introduce any adverse effect upon the airworthiness of the rotorcraft.
3. Rotorcraft equipped with the Onboard Systems Model 200-190-00 Cargo Hook Kit must be operated in accordance with FAA approved Rotorcraft Flight Manual Supplement (RFMS) No. 120-050-00, dated May 19, 1997 or later FAA approved revision. A copy of this Certificate and FAA Approved RFMS must be maintained as part of the permanent records for the modified rotorcraft.
4. If the STC holder agrees to permit another person to use this certificate to alter the product, the STC holder shall give the other person written evidence of that permission.

..... End

This page intentionally left blank.

FAA APPROVED

ROTORCRAFT FLIGHT MANUAL SUPPLEMENT

***Eurocopter Helicopter Models
AS-350B, AS-350B1, AS350B2, AS350BA & AS-350D***

R/N _____

S/N _____

FAA Approval:

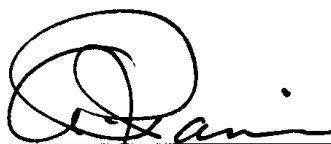

Manager, Special Certification Branch
Seattle Aircraft Certification Office

Date: Dec. 2, 1998

Revised: JAN 15 2001



Rotorcraft Flight
Manual Supplement

Document Number

120-050-00

Cargo Hook

Page

1

INTRODUCTION

This supplement must be attached to the appropriate DGAC approved Eurocopter Rotorcraft Flight Manual when an Onboard Systems 200-190-00 Cargo Hook Kit is installed in accordance with Supplemental Type Certificate (STC) NO. SR00439SE. The information contained herein supplements or supersedes the basic manual only in those areas listed herein. For limitations, procedures and performance information not contained in this supplement, consult the basic Rotorcraft Flight Manual.

I. LIMITATIONS

The basic Flight Manual remains applicable. When an Onboard Systems 200-190-00 Cargo Hook Kit is installed, the following placard applies:

- Mounted on bottom of Cargo Hook.

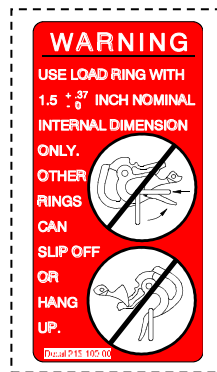

II. PERFORMANCE

The basic Flight Manual remains applicable.

III. PROCEDURES

Before each Cargo Hook use perform the following procedures. If the procedures are not successful do not use the equipment until the problem has been corrected.

- Inspect all mounting fasteners to ensure that they are tight.
- Visually inspect the electrical connector for loose or damaged pins and sockets.
- Operate the keeper manually and check that it snaps back to its normal position on the load beam.
- Inspect the case and covers for cracks and damage.
- Inspect the load beam for gouges and cracks.
- Cycle the manual release mechanisms to ensure proper operation.
- Cycle the electrical release mechanisms to ensure proper operation.

	Rotorcraft Flight Manual Supplement	Document Number 120-050-00
	Cargo Hook	Page 2

III. PROCEDURES, continued

Cargo Hook Rigging

Extreme care must be exercised in rigging a load to the Cargo Hook. If the load ring is too big it may work its way around the end of the load beam and be supported for a time on the keeper and then fall free. If the load ring is too small it may jam itself against the load beam during an attempted release. The following illustrations show recommended configurations and potential difficulties that must be avoided.

WARNING: The examples shown are not intended to represent all problem possibilities. It is the responsibility of the operator to assure the hook will function properly with the rigging.

Figure 1 Examples of correct and incorrect cargo hook rigging

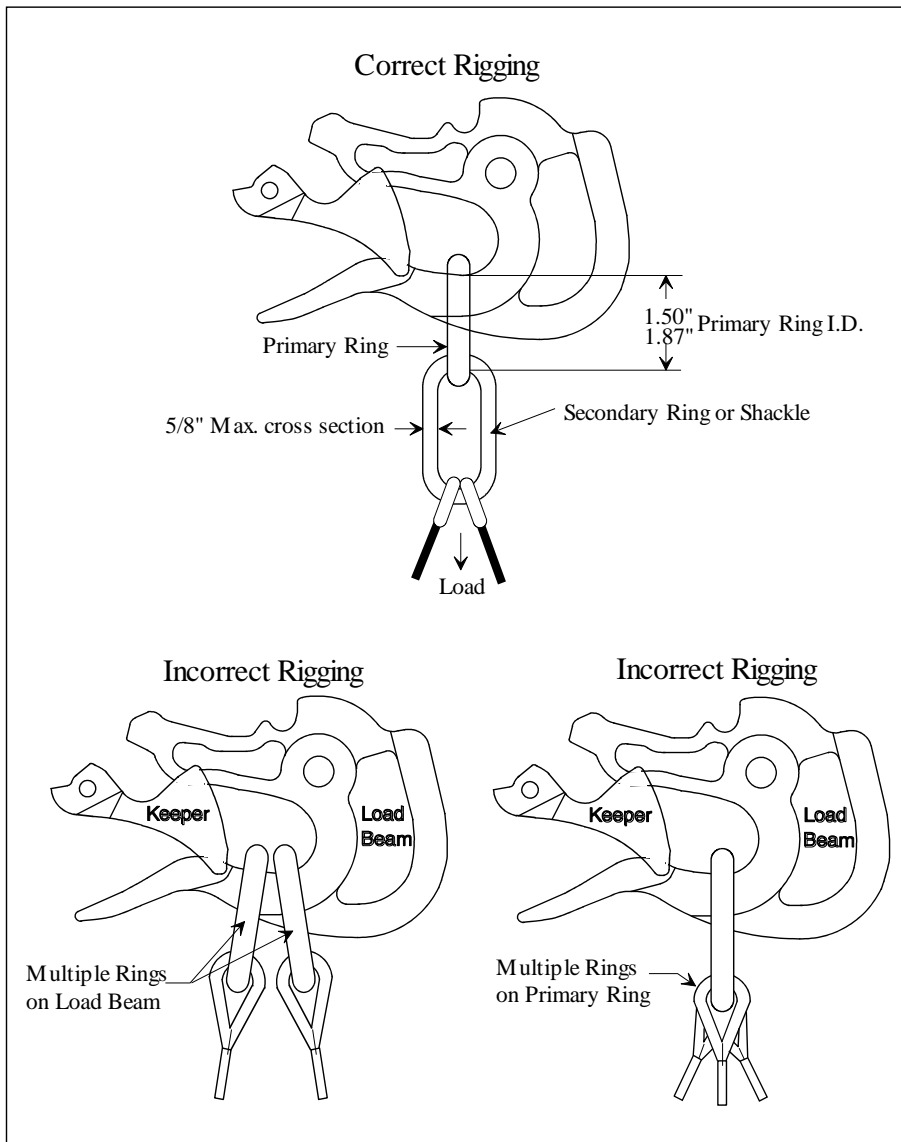

III. PROCEDURES, continued

Un-Commanded Release Due to Too Large of a Load Ring

WARNING: Load rings that are too large will cause an un-commanded release. The ring will flip over the end of the load beam and flip the keeper up and then fall free. Only correctly sized load rings must be used. See examples below.

Figure 2 Un-commanded release due to load rings that are too large

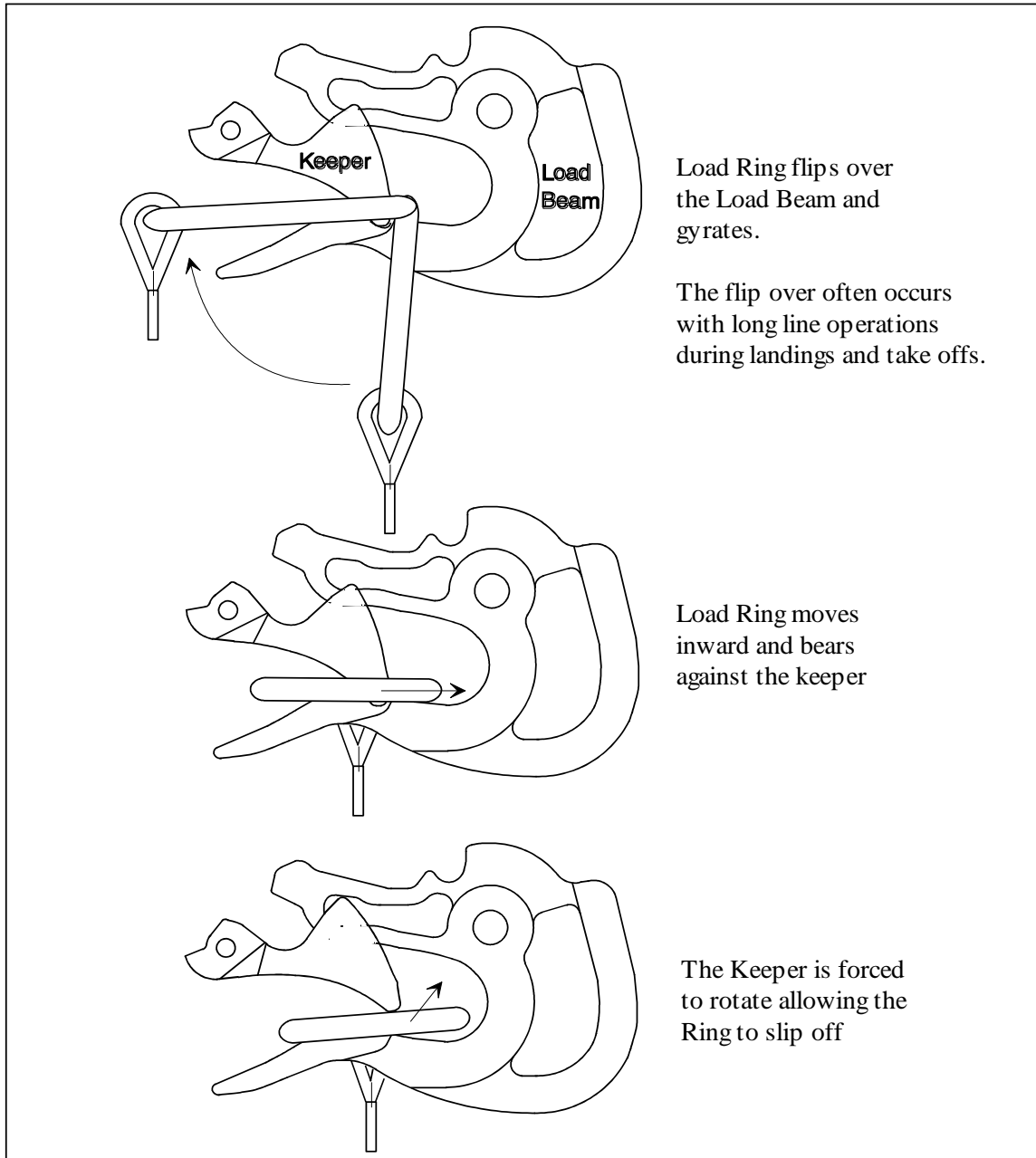

III. PROCEDURES, continued

Load Hang-Up Due to Too Small of a Load Ring or Multiple Load Rings

WARNING: Load rings that are too small or multiple load rings will hang on the load beam when the load is released. Only correctly sized load rings must be used. See examples below.

Figure 3 Load hang-up due to load rings that are too small or using multiple load rings

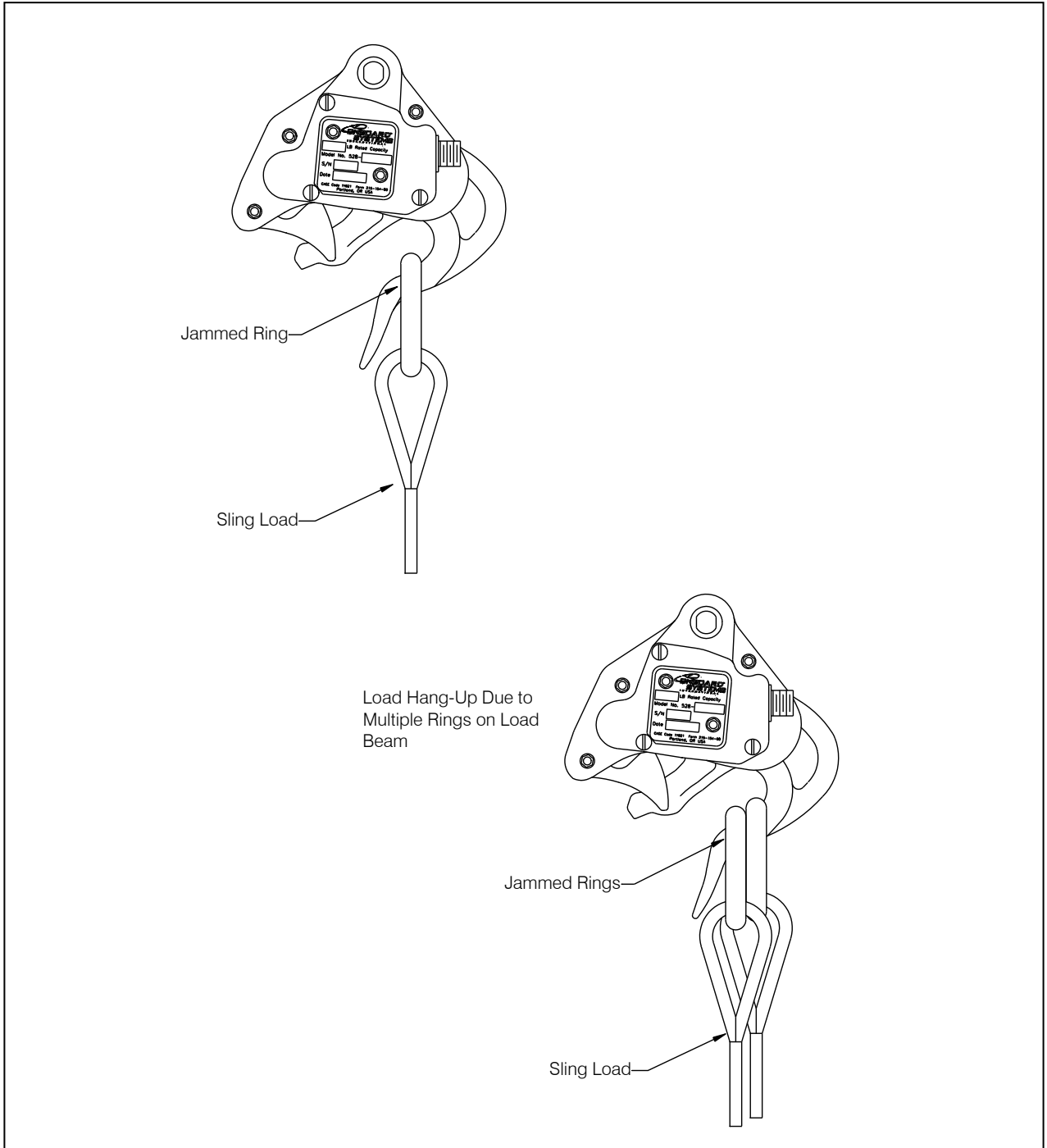

III. PROCEDURES, continued

Un-Commanded Release Due to Nylon Type Straps

WARNING: Nylon type straps (or similar material) must not be used directly on the cargo hook load beam as they have a tendency to creep under the keeper and fall free. If nylon straps must be used they should first be attached to a correctly sized primary ring. Only the primary ring should be in contact with the cargo hook load beam. See examples below.

Figure 4 Un-commanded release due to nylon type straps

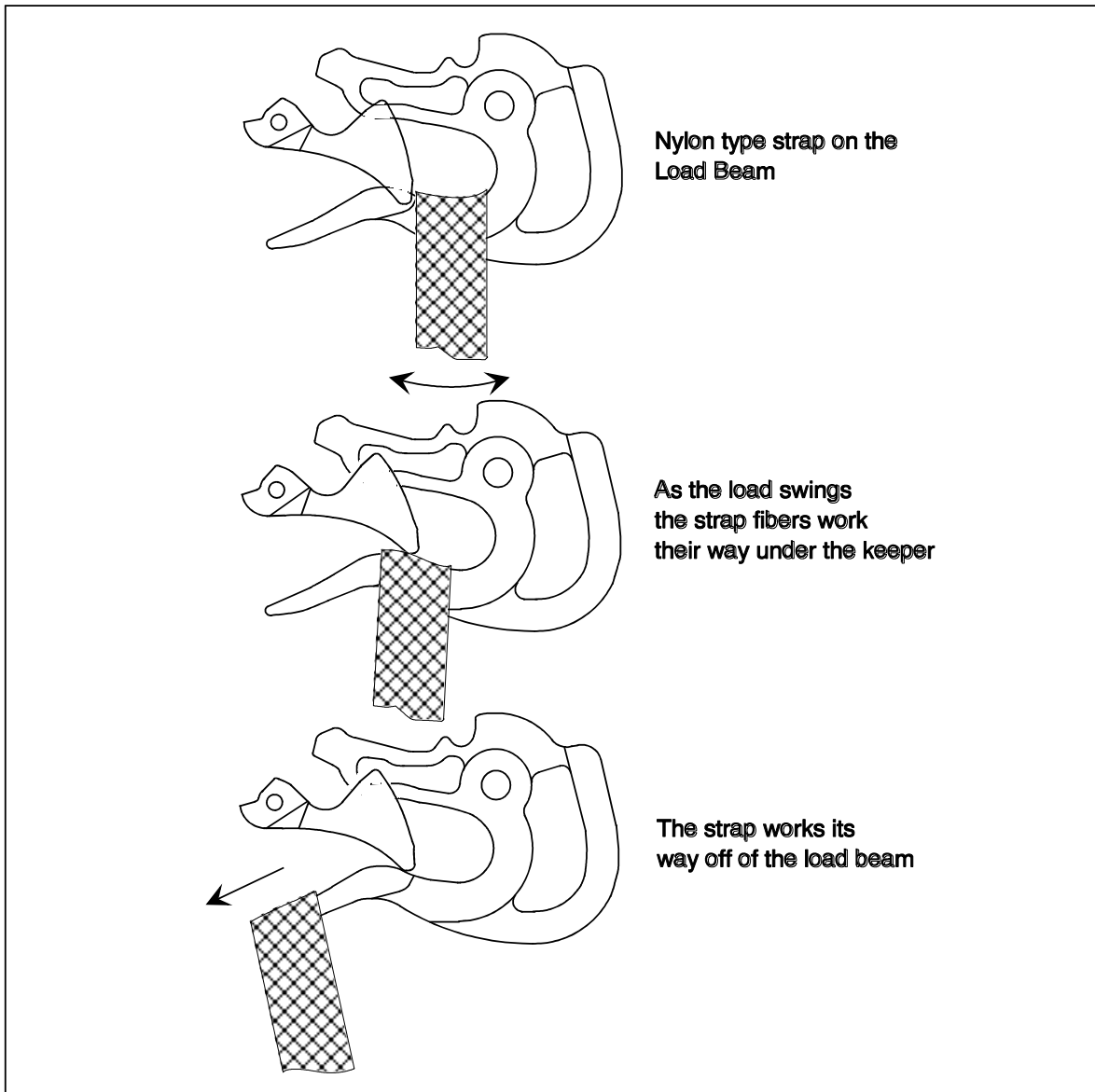

III. PROCEDURES, continued

Un-Commanded Release Due to Cable or Rope Type Straps

WARNING: Cable or rope type straps must not be used directly on the cargo hook load beam. Their braided eyes will work around the end of the load beam and fall free. If cable or rope is used they should first be attached to a correctly sized primary ring. Only the primary ring should be in contact with the cargo hook load beam. See examples below.

Figure 5 Un-commanded release due to cable or rope type straps

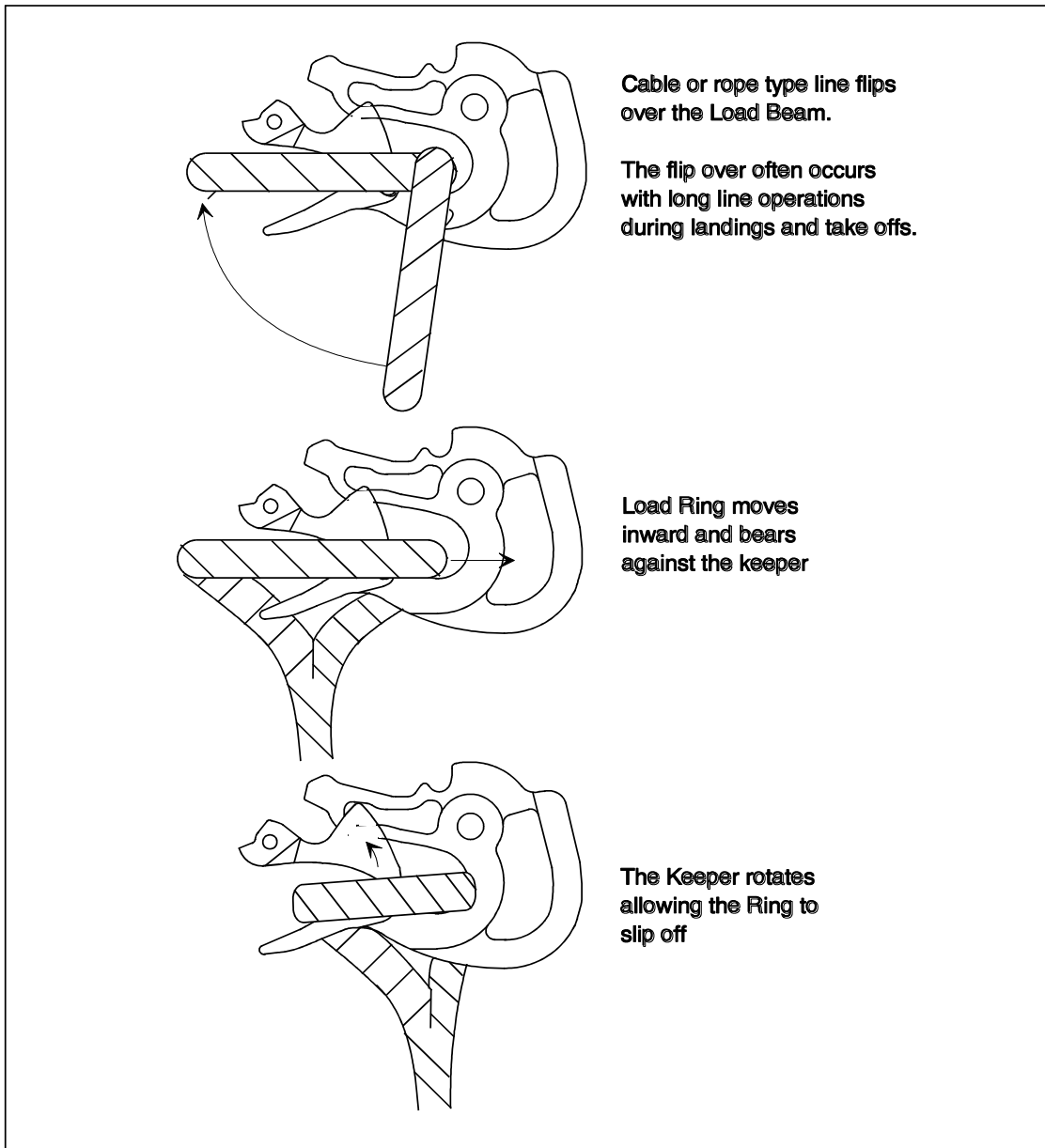

This page intentionally left blank.