

**PLEASE CHECK WEB SITE AT [WWW.ONBOARDSYSTEMS.COM](http://WWW.ONBOARDSYSTEMS.COM) FOR  
THE LATEST REVISION OF THIS MANUAL**

**MD500/600  
Cargo Hook  
Attach Point Kit**

**Kit Part Numbers**

**200-231-00**

**200-231-01**

**Owner's Manual**

Owner's Manual Number 120-073-00

Revision 7

October 20, 2010



13915 NW 3<sup>rd</sup> Court Vancouver Washington 98685 USA  
Phone: 360-546-3072 Fax: 360-546-3073 Toll Free: 800-275-0883  
[www.OnboardSystems.com](http://www.OnboardSystems.com)

This page intentionally left blank.

## RECORD OF REVISIONS

<i>Revision</i>	<i>Date</i>	<i>Page(s)</i>	<i>Reason for Revision</i>
2	9/17/02	Title, 4-2	Factory address change.
3	09/19/07	TOC, Section 1 & 2-1	Added explanation of warnings, cautions and notes to general information section. Updated warnings, cautions and notes throughout.
4	08/25/08	All	Added kit P/N 200-231-01, added 600N model, updated installation instructions, updated inspection requirements. Upgraded design load (Table 1-2) to 2200 lbs.
5	3/2/10	4-3	Changed overhaul frequency criteria.
6	4/16/10	All	Updated format of safety symbols, clarified inspection requirements.
7	10/20/10	4-3	Corrected inspection criteria for pivot link (P/N 290-480-00).

### **Register Your Products for Automatic Notifications**

Onboard Systems offers a free notification service via fax or email for product alerts and documentation updates. By registering your Onboard Systems products at our website, we will be able to contact you if a service bulletin is issued, or if the documentation is updated.

You can choose to receive notices on an immediate, weekly, or monthly schedule via fax, email or both methods. There is no charge for this service. Please visit our website at [www.onboardsystems.com/notify.php](http://www.onboardsystems.com/notify.php) to get started.

This page intentionally left blank.

# ***CONTENTS***

## ***Section 1* General Information**

Introduction, 1-1  
Explanation of Signal Words and Symbols, 1-1  
Bill of Materials, 1-2  
Inspection, 1-2  
Specifications, 1-2

## ***Section 2* Installation Instructions**

Installation, 2-1  
Installation Check-Out, 2-2  
Weight, 2-2  
Paper Work, 2-2

## ***Section 3* Operation Instructions**

Operating Procedures, 3-1

## ***Section 4* Maintenance**

Storage Instructions, 4-1  
Preventive Maintenance, 4-1  
Inspection, 4-2  
Instructions for Returning a System to the Factory, 4-4

## ***Section 5* Certification**

FAA STC, 5-1  
Transport Canada STC, 5-2  
EASA STC, 5-3

## ***Figures***

2-1 Attach Point Installation, 2-1  
4-1 Pivot Link Lubrication Points, 4-1

## ***Tables***

1-1 Bill of Materials, 1-2  
1-2 Specifications, 1-2  
2-1 Component Weights, 2-2  
4-1 Attach Point Inspection Criteria, 4-3

This page intentionally left blank.

# Section 1

## General Information

### Introduction

The 200-231-00 Cargo Hook Attach Point Kit is intended for installation on the MD Helicopters' 369D, 369E, 369F, 369FF, 369HM, 369HE, 369HS and 500N model helicopters. The cargo hook attach point bolts to the bottom of the helicopter and supports and provides a pivot point for the cargo hook. It can be used with the MD Part Number 369H90072 series of cargo hook kits or Onboard Systems cargo hook kits approved under STCs SR00407SE, SR00892SE, or SR01778SE.

The 200-231-01 Cargo Hook Attach Point Kit is intended for installation on the MD Helicopters' 600N model helicopter. It is the same as the 200-231-00 cargo hook kit except the attach point bolts are of longer grip length.

### Explanation of Signal Words and Symbols

The following definitions apply to the symbols used throughout this manual to draw the reader's attention to safety instructions as well as other important messages.



Indicates a hazardous situation which, if not avoided, will result in death or serious injury.



Indicates a hazardous situation which, if not avoided, could result in death or serious injury.



Indicates a hazardous situation which, if not avoided, could result in minor or moderate injury.



Draws the reader's attention to important or unusual information not directly related to safety.



Used to address practices not related to personal injury.

## Bill of Materials

The following items are included with the Attach Point Kits. If shortages are found contact the company from whom the system was purchased.

**Table 1-1 Bill of Materials**

Part No.	Description	200-231-00 Quantity	200-231-01 Quantity
290-480-00	Pivot Link	1	1
290-481-00	Pivot Cradle	1	1
290-482-00	Bearing Plate	1	1
510-290-00	Bolt	4	-
510-703-00	Bolt	-	4
510-291-00	Washer	4	4
510-100-00	Washer	4	4
120-073-00	Owner's Manual	1	1

## Inspection

Inspect the kit items for evidence of damage and corrosion. If damage is found, do not use the items until they are repaired.

## Specifications

**Table 1-2 Specifications**

Design Load*	2,200 lbs (998 kgs)
Design Ultimate Strength	9,000 lbs (4,082 kgs)



*\* The design load is an indication of the structural capacity of the Cargo Hook Attach Point. All helicopter external load limits as described in the RFM still apply.*



## Section 2

# Installation Instructions

These procedures are provided for the benefit of experienced aircraft maintenance facilities capable of carrying out the procedures. They must not be attempted by those lacking the necessary expertise.

### Installation

If present, remove existing cargo hook attach point components supplied as part of the MD Helicopters' cargo hook kit. Attach the Onboard Systems Attach Point using the hardware supplied, as illustrated below. Torque bolts to 50-80 in-lbs and safety wire.

Since these kits have built in travel limiters, the rubber pads glued to the skin can be removed at the operators option. Before removal of the pads, verify that the cargo hook does not contact the skin at the full limits of its travel.



*Although not required since the parts are dry film lubricated, application of Never Seize or grease to the mating surfaces between the cradle and the link will extend the life of the assembly.*

**Figure 2-1 Attach Point Installation**

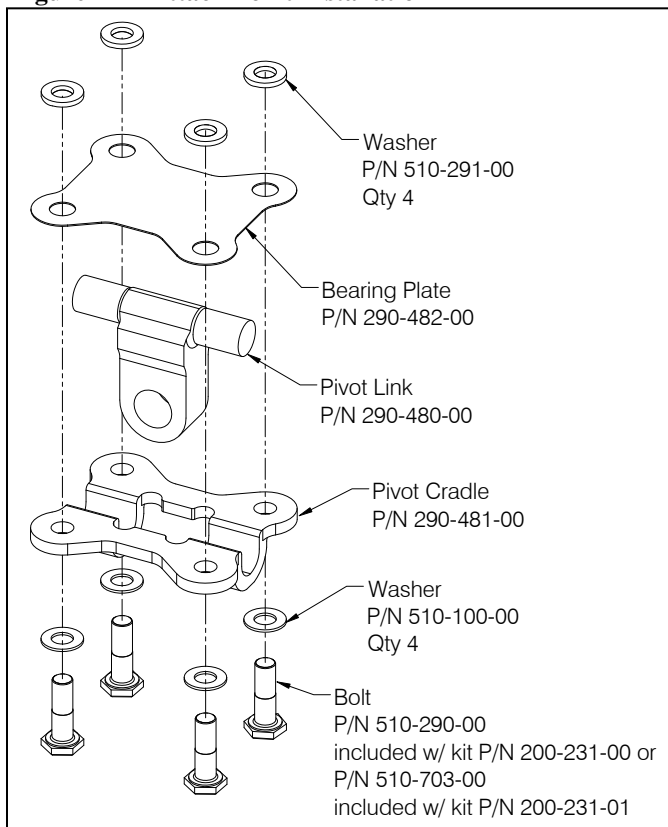

## Installation Check-out

After installing the attach point kit, perform the following functional checks.

1. Swing the pivot link throughout its range of motion and ensure it pivots freely.
2. If installed, swing the Cargo Hook to ensure that the manual release cable assembly and the electrical release harness have enough slack to allow full movement of the attach point assembly without straining or damaging the cables. The cables must not be the stops that prevent the Cargo Hook from swinging freely in all directions.

## Weight

**Table 2-1 Component Weights**

<b>Item</b>	<b>Weight</b>
Attach Point Kit	.75 lbs (.34 kgs)

## Paper Work

In the US, fill in FAA form 337 for the initial installation. This procedure may vary in different countries. Make the appropriate aircraft log book entry.

# *Section 3*

## **Operation Instructions**

### **Operating Procedures**

Prior to external load operations perform the following:

1. Ensure that the attach point hardware is secure and that the manual and electrical release cables do not limit the movement of the Attach Point Kit's Pivot Link or cargo hook.
2. Ensure that the attach point's pivot points freely rotate and that there is no binding.

This page intentionally left blank.

# Section 4

## Maintenance

### Storage Instructions

Clean the components thoroughly before packaging. Pack the unit in a heat-sealable package. If the unit is to be stored for long periods in a tropical climate it should be packed in a reliable manner to suit local conditions. Refer to relevant MIL specifications.

Package the unit in a suitable fiberboard box and cushion the unit to prevent shifting. Seal the fiberboard box with tape and mark the box with the contents and date of packaging.

### Preventive Maintenance

Remove caked-on dirt from the components with a brush and clean exposed surfaces with a mild solvent. Thoroughly dry all surfaces.

Annually, it is recommended that the Pivot Link be removed and grease applied (Mobilgrease 28 or similar) to the outside diameter of its arms and to the hole as shown in Figure 4-1.

**Figure 4-1 Pivot Link Lubrication Points**

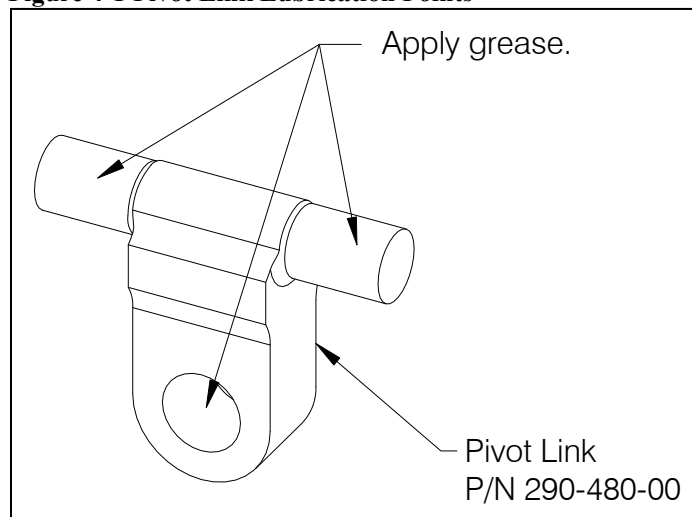

# Inspection

---

**Daily, prior to external load work, perform the following checks of the attach point kit. The pilot may accomplish these.**

---

1. Move the cargo hook and attach point throughout their full ranges of motion and observe the manual release cable and electrical harnesses. The release cable and harnesses must not be the stops that prevent the cargo hook or attach point from pivoting freely in all directions. Ensure the pivot points, including the pivot link within the cradle and the cargo hook pivot point, rotate freely.
2. Visually check for presence and security of the four bolts which secure the attach point to the helicopter.
3. Visually check the Pivot Link and Pivot Cradle for cracks and damage.

The scheduled inspection interval(s) noted below are maximums and are not to be exceeded. If the attach point kit is subjected to unusual circumstances, extreme environmental conditions, etc., it is the responsibility of the operator to perform the inspections more frequently to ensure proper operation.

---

**Annually or 100 hours of external load operations, whichever comes first, inspect the attach point kit components per the following.**

---

## NOTICE

*Hours of external load operations is defined as the time in which a helicopter is engaged in external load operations. This includes time between loads on the hook.*

1. Move the cargo hook and attach point throughout their full ranges of motion and observe the manual release cable and electrical harness. The release cable and harness must not be the stops that prevent the cargo hook or attach point from pivoting freely in all directions. Ensure the pivot points, including the pivot link within the cradle and the cargo hook pivot point, rotate freely.
2. Visually inspect for presence and security of the four bolts which secure the attach point to the helicopter.
3. Visually inspect the Pivot Link and Pivot Cradle for cracks and damage.

## Inspection continued

**Every 1000 hours of external load operations or 5 years, whichever comes first, remove the attach point kit components from the helicopter and inspect per the following.**

Carefully inspect, and if necessary repair, the detail parts in accordance with the instructions in Table 4-1. Inspect the parts in a clean, well-lit room.

Perform magnetic particle inspection in accordance with ASTM-E1444 and MIL-STD-1907, Grade A on the parts listed below. No cracks are permitted in any of these parts.

1. Pivot Link (P/N 290-480-00), Qty 1
2. Pivot Cradle (P/N 290-481-00), Qty 1

**Table 4-1 Attach Point Kit Inspection Criteria**

<b>Component</b>	<b>Damage Permitted without Repair</b>	<b>Repair</b>	<b>Maximum Damage which Causes Replacement</b>
Pivot Link P/N 290-480-00 (item 1, Figure 5.2.1)	Dents, nicks, gouges, scratches, and corrosion less than .005" deep.	Blend at 20:1 ratio, length to depth, to provide smooth transitions. Part is 15-5 stainless steel, no touch-up finish is required.	Dents, nicks, gouges and scratches greater than .030" deep.
	Wear on outside diameter of arms, diameter equal to or greater than .425".	None.	Wear on outside diameter of arms, diameter less than .425".
	Wear on inside of hole, diameter equal to or less than .515".	None.	Wear on inside of hole, diameter greater than .515".
			Cracks.
Pivot Cradle P/N 290-481-00 (item 2, Figure 5.2.1)	Dents, gouges, scratches, and corrosion less than .005" deep.	Blend at 20:1 ratio, length to depth, to provide smooth transitions.	Dents, gouges and scratches greater than .030" deep.
	Wear on inside radius, thickness of material is equal to or greater than .125".	None.	Wear on inside radius, thickness of material is less than .125".
			Cracks.

## Instructions for Returning Equipment to the Factory

If an Onboard Systems product must be returned to the factory for any reason (including returns, service, repairs, overhaul, etc) obtain an RMA number before shipping your return.



*An RMA number is required for all equipment returns.*

- To obtain an RMA, please use one of the listed methods.
  - Contact Technical Support by phone or e-mail ([Techhelp@OnboardSystems.com](mailto:Techhelp@OnboardSystems.com)).
  - Generate an RMA number at our website: <http://www.onboardsystems.com/rma.php>
- After you have obtained the RMA number, please be sure to:
  - Package the component carefully to ensure safe transit.
  - Write the RMA number on the outside of the box or on the mailing label.
  - Include the RMA number and reason for the return on your purchase or work order.
  - Include your name, address, phone and fax number and email (as applicable).
  - Return the components freight, cartage, insurance and customs prepaid to:

Onboard Systems  
13915 NW 3rd Court  
Vancouver, Washington 98685  
USA  
Phone: 360-546-3072



# Section 5

## Certification

### FAA STC

United States of America  
Department of Transportation—Federal Aviation Administration  
**Supplemental Type Certificate**

*Number* SR00525SE

*This certificate, issued to* Onboard Systems  
13915 NW 3rd Court  
Vancouver, WA 98685

*certifies that the change in the type design for the following product with the limitations and conditions therefor as specified hereon meets the airworthiness requirements of Part 6 of the Civil Air Regulations.*

*Original Product—Type Certificate Number:* H3WE  
*Make:* McDonnell Douglas Helicopters Company  
*Model:* 369D, 369E, 369F, 369FF, 369HE, 369HM, 369HS, 500N, and 600N

*Description of the Type Design Change:* Fabrication of Onboard Systems Model 200-231-00 and 200-231-01 Cargo Hook Attach Point Kits in accordance with FAA-Approved Onboard Systems Master Drawing List No. 155-038-00, Rev. 6, dated August 26, 2008, or later FAA-approved revision; and installation of these Cargo Hook Attach Point Kits in accordance with FAA-approved Onboard Systems Owner's Manual No. 120-073-00, Rev. 4, dated August 25, 2008, or later FAA-approved revision. Inspect the Attach Point Kit in accordance with Section 4 of Onboard Systems Owner's Manual No. 120-073-00, Rev. 4, dated August 25, 2008, or later FAA-approved revision.

*Limitations and Conditions:* Approval of this change in type design applies to only those McDonnell Douglas model rotorcraft listed above. This approval should not be extended to rotorcraft of these models on which other previously approved modifications are incorporated unless it is determined by the installer that the relationship between this change and any of those other previously approved modifications, including changes in type design, will introduce no adverse effect upon the airworthiness of that rotorcraft. No Rotorcraft Flight Manual revision is deemed necessary for this Cargo Hook Attach Point Kit installation. A copy of this certificate must be maintained as part of the permanent records of the modified rotorcraft.

If the holder agrees to permit another person to use this certificate to alter the product, the holder shall give the other person written evidence of that permission.

*This certificate and the supporting data which is the basis for approval shall remain in effect until surrendered, suspended, revoked, or a termination date is otherwise established by the Administrator of the Federal Aviation Administration.*

*Date of application:* May 12, 1998  
*Date of issuance:* June 22, 1998

*Date reissued:*  
*Date amended:* January 13, 2003, October 8, 2008



*By directing of the Administrator*

A handwritten signature in black ink, appearing to be "J. D. ...", written over a horizontal line.

(Signature)

Acting Manager, Seattle Aircraft  
Certification Office

(Title)

Any alteration of this certificate is punishable by a fine of not exceeding \$1,000, or imprisonment not exceeding 3 years, or both.

This certificate may be transferred in accordance with FAR 21.47.

FAA FORM 8110-2(10-88)



# Supplemental Type Certificate

**This approval is issued to:**

Onboard Systems  
13915 North West 3rd Court  
Vancouver, Washington  
United States of America 98685

**Number:** SH98-47

**Issue No.:** 3

**Approval Date:** September 14, 1998

**Issue Date:** November 15, 2011

**Responsible Office:**

Pacific

**Aircraft/Engine Type or Model:**

McDonnell Douglas HC  
369D, E, F, FF, HE, HM, HS, 500N, and 600N

**Canadian Type Certificate or Equivalent:**

H3WE (369 Series), H-95 (500N, 600N)

**Description of Type Design Change:**

Fabrication and Installation of Onboard Systems Cargo Hook Attach Point per FAA STC SR00525SE

**Installation/Operating Data,  
Required Equipment and Limitations:**

**Fabrication** of Onboard Systems Model 200-231-00, 200-231-01, 200-231-02 and 200-231-03 Cargo Hook Attach Point in accordance with FAA approved Onboard Systems Master Drawing List No. 155-038-00, Rev. 9, dated March 9, 2011 \*; and,

**Installation** of 200-231-00 or 200-231-01 Cargo Hook Attach Point Kit in accordance with FAA approved Onboard Systems Owner's Manual No. 120-073-00, Rev. 9, dated March 9, 2010 \*; or of 200-231-02 or 200-231-03 Cargo Hook Attach Point Kit in accordance with FAA approved Onboard Systems Owner's Manual No. 120-073-01, Rev. 0, dated February 28, 2011 \*.

**Inspect and Maintain** Cargo Hook Attach Point Kit in accordance with Section 4 of Onboard Systems Owner's Manual No. 120-073-00, Rev. 9, dated March 9, 2011 \* for Onboard Systems Model 200-231-00 and 200-231-01; or Owner's Manual No. 120-073-01, Rev. 0, dated February 28, 2011 \* for Onboard Systems Model 200-231-02 and 200-231-03.

(\* or later FAA approved revisions)

- End -



**Conditions:** This approval is only applicable to the type/model of aeronautical product specified therein. Prior to incorporating this modification, the installer shall establish that the interrelationship between this change and any other modification(s) incorporated **will not** adversely affect the airworthiness of the modified product.

H. W. Wong  
For Minister of Transport

Canada



European Aviation Safety Agency

SUPPLEMENTAL TYPE CERTIFICATE

EASA.IM.R.S.01530

This Supplemental Type Certificate is issued by EASA, acting in accordance with Regulation (EC) No. 216/2008 on behalf of the European Community, its Member States and of the European third countries that participate in the activities of EASA under Article 66 of that Regulation and in accordance with Commission Regulation (EC) No. 1702/2003 to

Onboard Systems International

13915 NW 3rd Court
Vancouver
WA 98685
United States

and certifies that the change in the type design for the product listed below with the limitations and conditions specified meets the applicable Type Certification Basis and environmental protection requirements when operated within the conditions and limitations specified below:

Original Product Type Certificate Number: FAA TC H3 WE
Type Certificate Holder: McDonnell Douglas
Model: MD Helicopters 369D, 369E, 369F, 369FF, 369HE, 369HM, 369HS, 500N, 600N
Original STC Number: FAA STC SR00525SE

Description of Design Change:

Installation of Onboard Systems Model 200-231-00 and 200-231-01 Cargo Hook Attach Point Kits in accordance with Onboard Systems Master Drawing List No. 155-038-00, Rev. 6, dated August 26, 2008, or later approved revision.

Associated Technical Documentation:

- Installation: Installation of the Cargo Hook Attach Point Kits must be done in accordance with FAA-approved Onboard Systems Owner's Manual No. 120-073-00, Rev. 4, dated August 25, 2008, or later approved revision.
- Inspection: Inspection of the Attach Point Kit should be done in accordance with Section 4 of Onboard Systems Owner's Manual No. 120-073-00, Rev. 4, dated August 25, 2008, or later approved revision.

Limitations and Conditions:

Prior to installation of this modification the installer must determine that the interrelationship between this modification and any other previously installed modification will introduce no adverse effect upon the airworthiness of the product. The installation of this modification by third persons is subject to written permission of the approval holder and holding and disposal of the approved appropriate documentation.

This Certificate shall remain valid unless otherwise surrendered or revoked.

For the European Aviation Safety Agency,

Date of issue: 08 June 2009

Handwritten signature of Massimo MAZZOLETTI
Massimo MAZZOLETTI
Certification Manager

STC - EASA.IM.R.S.01530 - Onboard Systems International