

**PLEASE CHECK WEB SITE AT WWW.ONBOARDSYSTEMS.COM FOR
THE LATEST REVISION OF THIS MANUAL**

Big Mouth Cargo Hook Kit
for the
Bell 206 A & B Series

Kit Part Number 200-232-00

Owner's Manual

Owner's Manual Number 120-074-00
Revision 8
September 14, 2010



13915 NW 3rd Court Vancouver Washington 98685 USA
Phone: 360-546-3072 Fax: 360-546-3073 Toll Free: 800-275-0883
www.OnboardSystems.com

This page intentionally left blank.

RECORD OF REVISIONS

<i>Revision</i>	<i>Date</i>	<i>Page(s)</i>	<i>Reason for Revision</i>
2	3-9-00	4-8,4-9	Added additional location option of connector plug on solenoid cover.
3	6-26-00	2-1, 2-2, 2-5, & Section 4	Figure 2-1 changed washer part number and added Torque value to AN Nut. Figure 2-2 added torque value. Page 2-2 added Hook location table. Removed overhaul instructions from Section 4 and moved information to the new Service Manual 122-002-00.
4	9/17/02	Title, 4-3	Factory address change.
5	01/18/07	2-2, 2-3 & 2-4 Section 4	Updated figures to show new knob configuration. Updated maintenance information to refer to service manual 122-002-00.
6	04/12/07	TOC, Section 1, 2-4 & Section 3	Updated Warnings, Cautions and Notes format to current standards.
7	06/16/10	TOC & Sections 1-4	Added Manual Release Cable (P/N 268-015-00) to parts list. Added installation instructions for manual release cable. Replaced warnings, cautions and notes section with safety labels section. Updated safety labels throughout document. Updated inspection and overhaul information.
8	09/14/10	4-3	Added Figure 4.4, added Link Assembly bushing installation instructions, updated bushing wear criteria.

Register Your Products for Automatic Notifications

Onboard Systems offers a free notification service via fax or email for product alerts and documentation updates. By registering your Onboard Systems products at our website, we will be able to contact you if a service bulletin is issued, or if the documentation is updated.

You can choose to receive notices on an immediate, weekly, or monthly schedule via fax, email or both methods. There is no charge for this service. Please visit our website at www.onboardsystems.com/notify.php to get started.

This page intentionally left blank.

CONTENTS

Section 1 **General Information**

Introduction, 1-1
Safety Labels, 1-1
Bill of Materials, 1-2
Inspection, 1-2
Specifications, 1-2
Theory of Operation , 1-3

Section 2 **Installation Instructions**

Cargo Hook and Manual Release Cable Removal, 2-1
Cargo Hook Kit Installation, 2-1
Installation Check-Out, 2-6
Component Weights, 2-6
Cargo Hook Location, 2-6
Paper Work, 2-6

Section 3 **Operation Instructions**

Operating Procedures, 3-1
Cargo Hook Rigging, 3-2
Cargo Hook Rigging Illustrations, 3-3

Section 4 **Maintenance**

Storage Instructions, 4-1
Preventive Maintenance, 4-1
Inspection, 4-1
Adapter Link Overhaul, 4-3
Instructions for Returning a System to the Factory, 4-4

CONTENTS, continued

Section 5 Certification

STC, 5-1

STA, 5-3

Rotorcraft Flight Manual Supplement

Figures

- 2-1 Manual Release Cable Installation, 2-1
- 2-2 Link Adapter Assembly Installation, 2-2
- 2-3 Cargo Hook Assembly to Cargo Frame Assembly, 2-2
- 2-4 Manual Release Cable Rig, 2-3
- 2-5 Adel Clamp and Shock Cord Installation, 2-3
- 2-6 Cargo Frame Assembly Overview, 2-4
- 2-7 Un-commanded Release, 2-5
- 3-1 Examples of Correct and Incorrect Cargo Hook Rigging, 3-3
- 3-2 Un-commanded Release Due to Large Load Ring, 3-4
- 3-3 Load Hang-Up, Too Small or Multiple Load Rings, 3-5
- 3-4 Un-Commanded Release Due to Nylon Straps, 3-6
- 3-5 Un-Commanded Release Due to Cable or Rope Straps, 3-7
- 4-1 Link Assembly Parts, 4-2

Tables

- 1-1 Cargo Hook Specifications, 1-1
- 2-1 Cargo Hook Connector, 2-3
- 2-2 Component Weights, 2-5
- 2-3 Cargo Hook Location, 2-5

Section 1

General Information

Introduction

The P/N 200-232-00 Cargo Hook kit is approved for installation on the 206A and 206B. The kit replaces the Breeze-Eastern hooks, SP4232-4, -5 and -5L when used as part of the Bell Cargo Hook Suspension Assembly, P/N 206-706-335-1, -101 or -103. The helicopter must also be equipped with the Bell Cargo Hook Provisions Kit, P/N 206-706-335-3, -5 or -105.

Safety Labels

The following definitions apply to the symbols used throughout this manual to draw the reader's attention to safety instructions as well as other important messages.



Indicates a hazardous situation which, if not avoided, will result in death or serious injury.



Indicates a hazardous situation which, if not avoided, could result in death or serious injury.



Indicates a hazardous situation which, if not avoided, could result in minor or moderate injury.



Draws the reader's attention to important or unusual information not directly related to safety.



Used to address practices not related to personal injury.

Bill of Materials

The following items are included with the Cargo Hook Kit, if shortages are found contact the company from whom the system was purchased.

Part Number	Description	Quantity
120-074-00	Cargo Hook Kit Owner's Manual	1
122-002-00	Big Mouth Hook Service Manual	1
210-164-00	Adapter Link Assembly	1
268-015-00*	Manual Release Cable	1
290-426-00	Release Fitting	1
510-252-00	Jam Nut	1
512-010-00	Adel Clamp	2
528-017-00	Cargo Hook	1



** Kits sold after June 16, 2010 include the Manual Release Cable, prior to this the kit utilized the existing OEM release cable.*

Inspection

Inspect the kit items for evidence of damage, corrosion and security of lock wire and fasteners. If damage is evident, do not use the items until they are repaired.

Specifications

Table 1-1 Cargo Hook Specifications

Design load	3,500 lb. (1,587 kg.)
Design ultimate strength	15,750 lb. (7,144 kg.)
Electrical release capacity	8,750 lb. (3,969 kg.)
Mechanical release capacity	8,750 lb. (3,969 kg.)
Force required for mechanical release at 3,500 lb.	10 lb. Max. (.600" travel)
Electrical requirements	22-28 VDC, 9.8-12.5 amps
Minimum release load	10 pounds
Unit weight	5.75 pounds (2.6 kg.)
Mating electrical connector	PC06A8-2S SR

Theory of Operation

The primary elements of the Cargo Hook are the load beam, the internal mechanism, and a DC solenoid. The load beam supports the load and is latched through the internal mechanism. The DC solenoid and an external manual release cable provide the means for unlatching the load beam.

The load beam is normally returned to its closed position after release of the load by a spring in the internal mechanism. In the closed position, a latch engages the load beam and latches it in this position. The load is attached to the load beam by passing the cargo sling ring into the throat of the load beam past a spring-loaded keeper, which secures the load.

To release the load, the latch is disengaged from the load beam. With the latch disengaged, the weight of the load causes the load beam to swing to its open position, and the cargo sling slides off the load beam. A spring in the internal mechanism then drives the load beam back to its closed and latched position.

A load release can be initiated by three different methods. Normal release is achieved by pilot actuation of the push-button switch in the cockpit. When the push-button switch is pressed, it energizes the DC solenoid in the Cargo Hook, and the solenoid opens the latch in the internal mechanism. In an emergency, release can be achieved by operating a mechanical release cable. The manual release cable operates the internal mechanism of the Cargo Hook to unlatch the load beam. The load can also be released by the actuation of a knob located on the side of the Cargo Hook.

This page intentionally left blank.

Section 2

Installation Instructions

These procedures are provided for the benefit of experienced aircraft maintenance facilities capable of carrying out the procedures. They must not be attempted by those lacking the necessary expertise.

Cargo Hook and Manual Release Cable Removal

Disconnect the manual and electrical release cables from the Cargo Hook. Remove the Cargo Hook from the universal assembly leaving the universal assembly attached to the cargo suspension assembly. Disconnect and remove the manual release cable from the cargo suspension assembly

Cargo Hook Kit Installation

Inspect the cargo frame assembly to insure that all components are in serviceable condition.

Attach the link adapter assembly to the Cargo Hook using the hardware supplied, as illustrated below. Torque AN nut 510-170-00 to 50 in-lbs, then rotate nut to next castellation, not to exceed 110 in-lbs. Install and secure cotter pin 510-178-00.

Figure 2-1 Link Adapter Assembly Installation

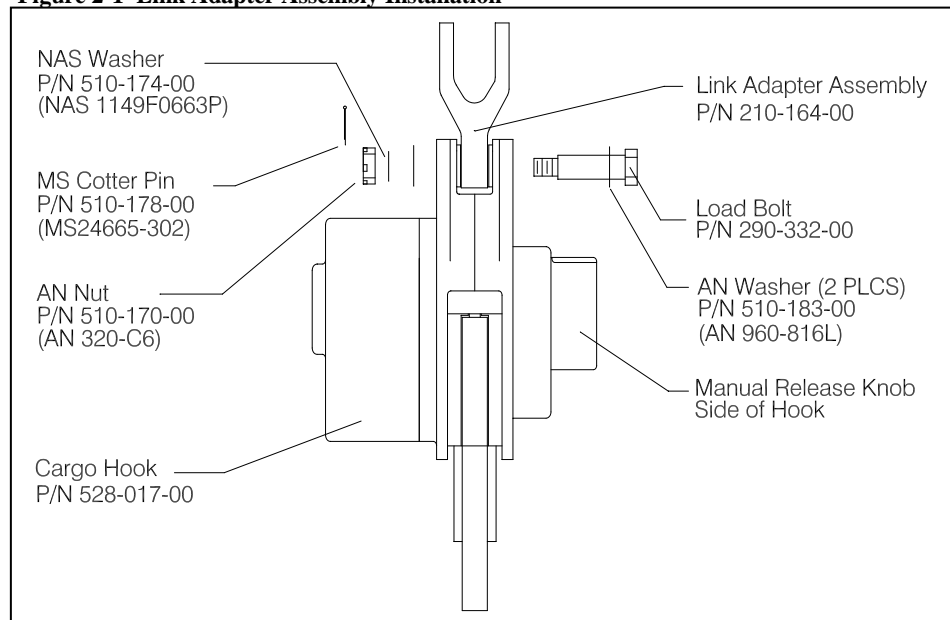

Cargo Hook Kit Installation, continued

Attach the Cargo Hook assembly to the cargo frame assembly using the Bell supplied hardware that was previously used to attach the universal assembly to the Cargo Hook. The cargo hook load beam should point to the right.

Figure 2-2 Cargo Hook Assembly to Cargo Frame Assembly Installation

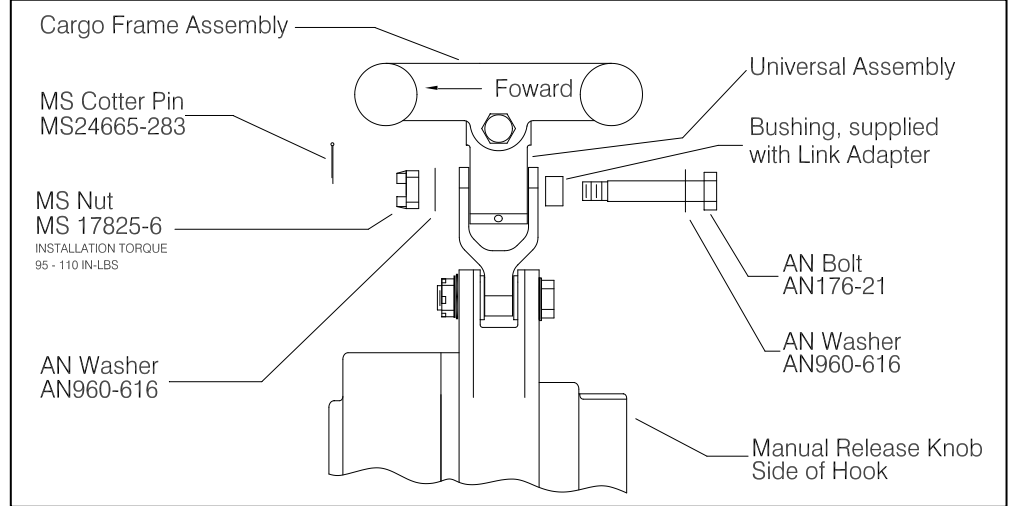

Attach the manual release cable to the cargo suspension assembly, as illustrated below.

Figure 2-3 Manual Release Cable Installation

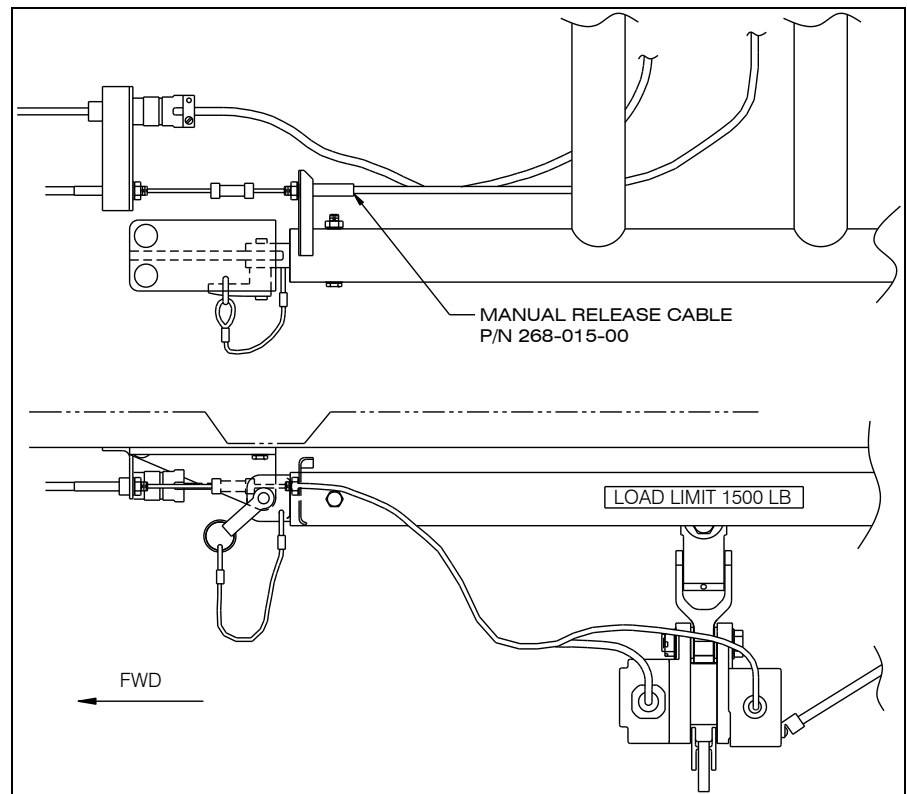

Cargo Hook Installation, continued

Thread the release fitting (P/N 290-426-00) into the cargo hook.

Remove the cargo hook manual release cover and connect the manual release cable. Place the cable ball end fitting into the hook manual release fork fitting as illustrated in Figure 2-4. Check that there is a minimum of .125" of free play at the fork fitting as shown in Figure 2-4.

Figure 2-4 Manual Release Cable Rig

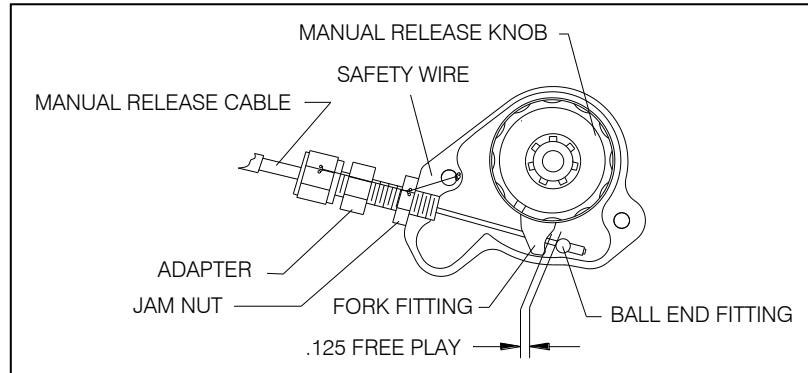

Attach the supplied adel clamps through the end loops of the cargo hook restraining shock cord. Route the shock cord through the eyelet and over the threaded rod as illustrated in Figures 2-4 and 2-5. Secure the adel clamps to the screws on the cargo hook manual release cover as illustrated and safety wire.

Figure 2-5 Adel Clamp and Shock Cord Installation

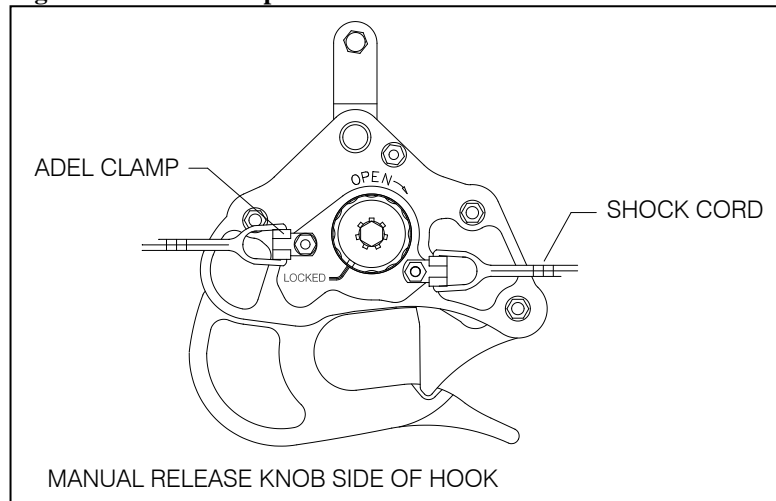

Cargo Hook Installation, continued

Figure 2-6 Cargo Frame Assembly Overview

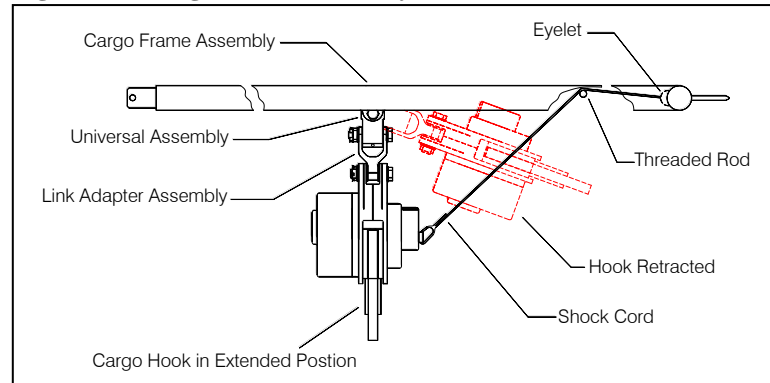

Connect the cargo hook electrical release cable connector to the Cargo Hook. Listed below is the pin out for the cargo hook connector.

Table 2-1 Cargo Hook Connector

<i>Pin</i>	<i>Function</i>
A	Ground
B	Power

Cargo Hook Installation, continued



Un-commanded cargo hook release will happen if the manual and electrical release cables are improperly restrained. The cables must not be the stops that prevent the Cargo Hook from swinging freely in all directions. If the Cargo Hook loads cause the hook to strain against the manual release cable the swaged end of the cable may separate allowing the inner cable to activate the cargo hook manual release mechanism. The result is an un-commanded release. Ensure that no combination of cyclic stick or Cargo Hook position is restrained by the manual or electrical release cables.

Figure 2-7 Un-commanded Release From Incorrectly Secured Cable

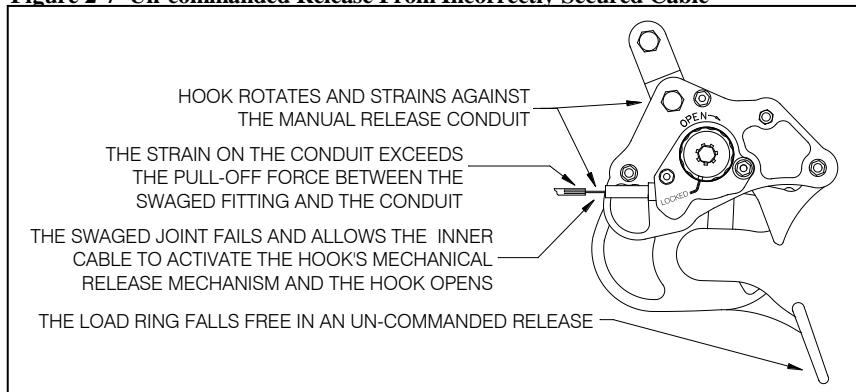

Installation Check-Out

After installation of the Cargo Hook, perform the following functional checks.

1. Swing the installed Cargo Hook to ensure that the manual release cable assembly and the electrical release cable have enough slack to allow full swing of the suspension assembly without straining or damaging the cables. The cables must not be the stops that prevent the Cargo Hook from swinging freely in all directions.
2. Apply 10-20 pounds to the cargo hook load beam and pull the handle operated cargo hook mechanical release, the Cargo Hook should release.
3. Close the cargo hook release circuit breaker and position the battery switch to the ON position. Apply 10-20 pounds to the cargo hook load beam and depress the cargo hook electrical release button, the Cargo Hook should release.
4. See the Bell Helicopter service instructions for your specific helicopter model for additional installation instructions.

Component Weights

The weight of the cargo hook components are listed in Table 2-2.

Table 2-2 Component Weights

Item	Weight lbs (kgs)
Cargo Hook	5.75 (2.61)
Link Adapter assembly	1.0 (.45)
Manual Release Cable	.25 (.11)

Cargo Hook Location

Table 2-3 Cargo Hook Location

Fuselage Station	108.5
------------------	-------

Paper Work

Remove the Flight Manual Supplement from the back of this manual and place it into the Rotorcraft Flight Manual. In the US, fill in FAA form 337 for the initial installation. This procedure may vary in different countries. Make the appropriate aircraft log book entry.

Section 3

Operation Instructions

Operating Procedures

Prior to each job perform the following:

1. Ensure that the Cargo Hook has been properly installed and that the manual and electrical release cables do not limit the movement of the hook.
2. Be completely familiar with this manual, particularly the Cargo Hook rigging section.
3. Be completely familiar with all Bell Helicopter Cargo Hook operating instructions.
4. Activate the electrical system and press the release button to ensure the cargo hook electrical release is operating correctly. The Cargo Hook must relatch after release. If the hook does not relatch do not use the unit until the difficulty is resolved.

CAUTION

The cargo hook release solenoid is intended to be energized only intermittently. Depressing the electrical release button continuously in excess of 20 seconds will cause the solenoid to overheat, possibly causing permanent damage.

5. Activate the manual release knob to test the cargo hook manual release mechanism. The mechanism should operate smoothly and the Cargo Hook must relatch after release. If the hook does not relatch do not use the unit until the difficulty is resolved.

See the trouble shooting table in Section 4 and the Bell service instructions that cover the original Cargo Hook installation for additional instructions.

Cargo Hook Rigging

Extreme care must be exercised in rigging a load to the Cargo Hook. If the load ring is too big it may work its way around the end of the load beam and be supported for a time on the keeper and then fall free. If the load ring is too small it may jam itself against the load beam during an attempted release. The following illustrations show recommended configurations and potential difficulties that must be avoided.



The examples shown are not intended to represent all problem possibilities. It is the responsibility of the operator to assure the hook will function properly with the rigging.

Cargo Hook Rigging, continued

Figure 3-1 Examples of Correct and Incorrect Cargo Hook Rigging

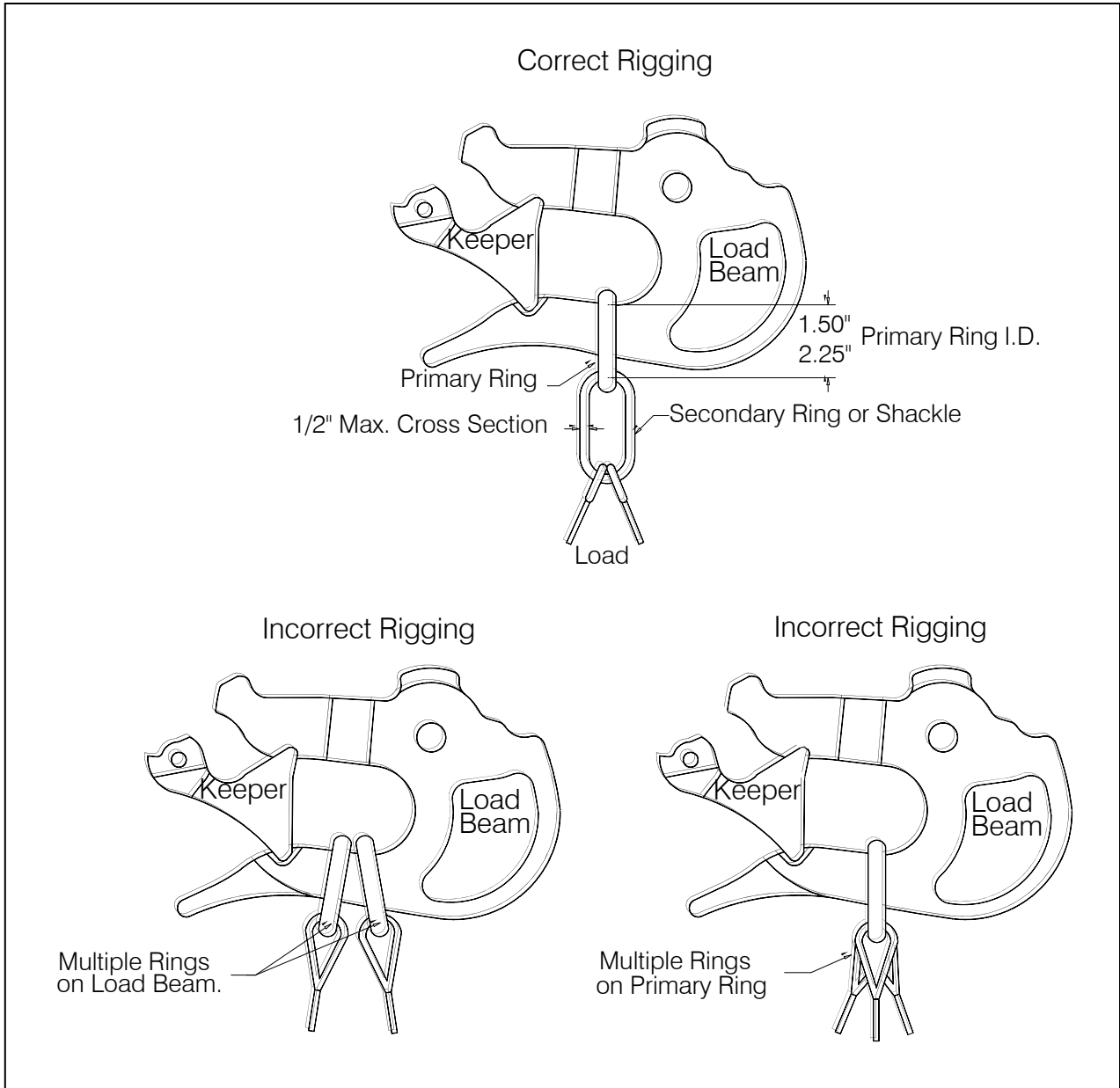

Un-Commanded Release Due to Too Large of a Load Ring



Load rings that are too large will cause an un-commanded release. The ring will flip over the end of the load beam and flip the keeper up and then fall free. Only correctly sized load rings must be used. See examples below.

Figure 3-2 Un-Commanded Release Due to Too Large of a Load Ring

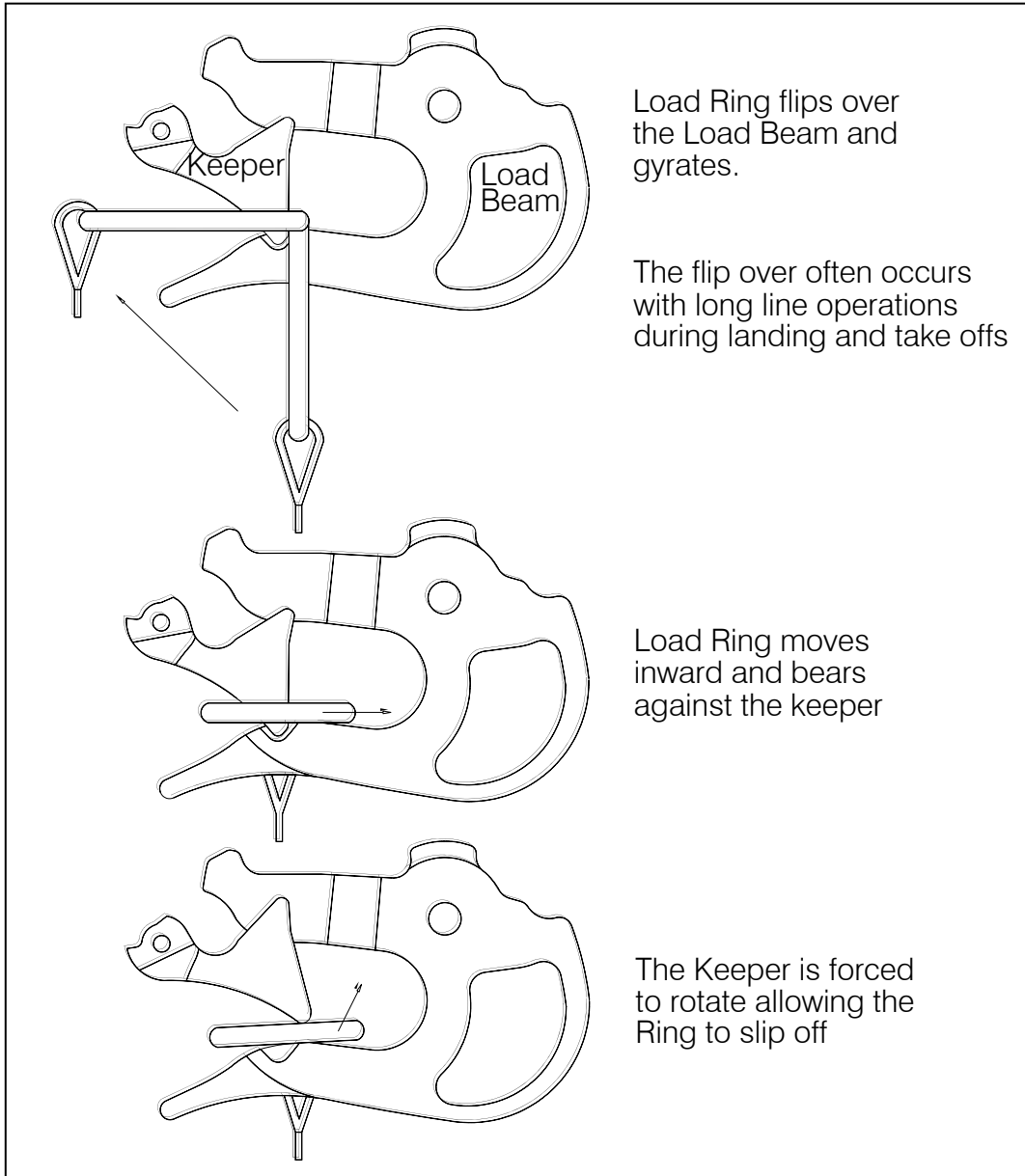

Load Hang-Up Due to Too Small of a Load Ring or Multiple Load Rings



Load rings that are too small or multiple load rings will hang on the load beam when the load is released. Only correctly sized load rings must be used. See examples below.

Figure 3-3 Load Hang-Up Due to Too Small a Load Ring or Multiple Load Rings

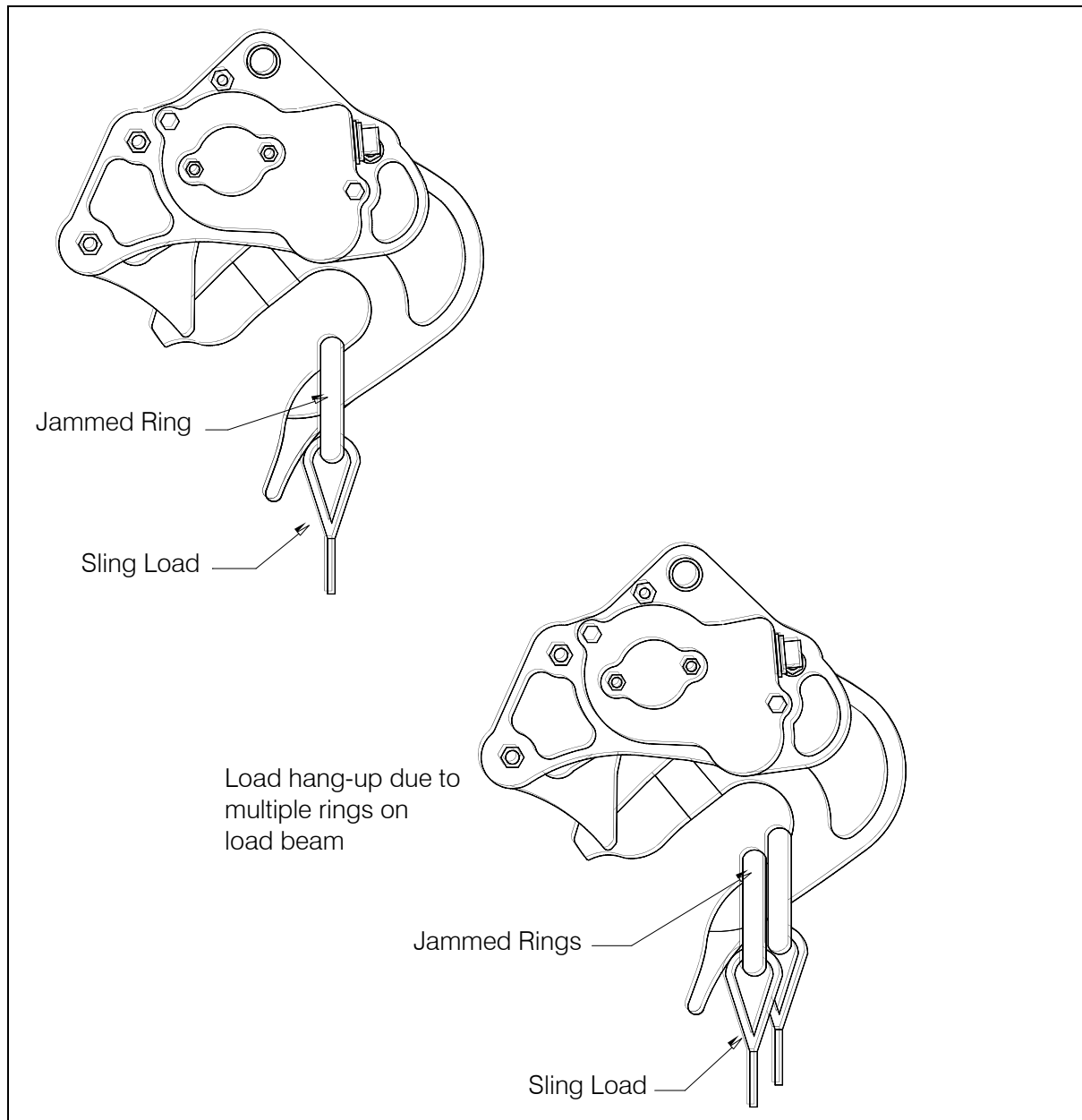

Un-Commanded Release Due to Nylon Type Straps



Nylon type straps (or similar material) must not be used directly on the cargo hook load beam as they have a tendency to creep under the keeper and fall free. If nylon straps must be used they should be first attached to a correctly sized primary ring. Only the primary ring should be in contact with the cargo hook load beam. See examples below.

Figure 3-4 Un-Commanded Release Due to Nylon Type Straps

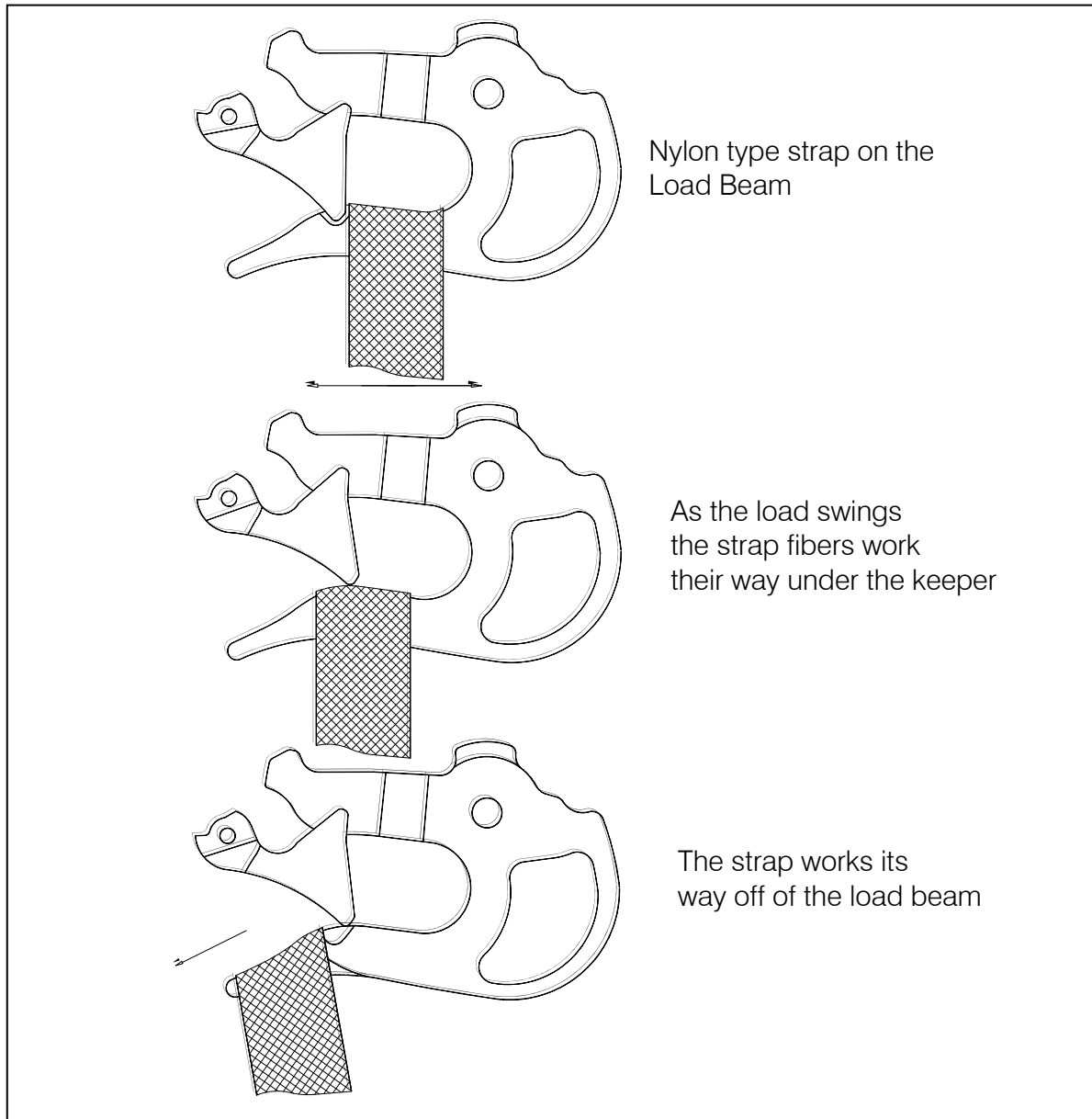

Un-Commanded Release Due to Cable or Rope Type Straps



Cable or rope type straps must not be used directly on the cargo hook load beam. Their braided eyes will work around the end of the load beam and fall free. If cable or rope is used they should be first attached to a correctly sized primary ring. Only the primary ring should be in contact with the cargo hook load beam. See examples below.

Figure 3-5 Un-Commanded Release Due to Cable or Rope Type Straps

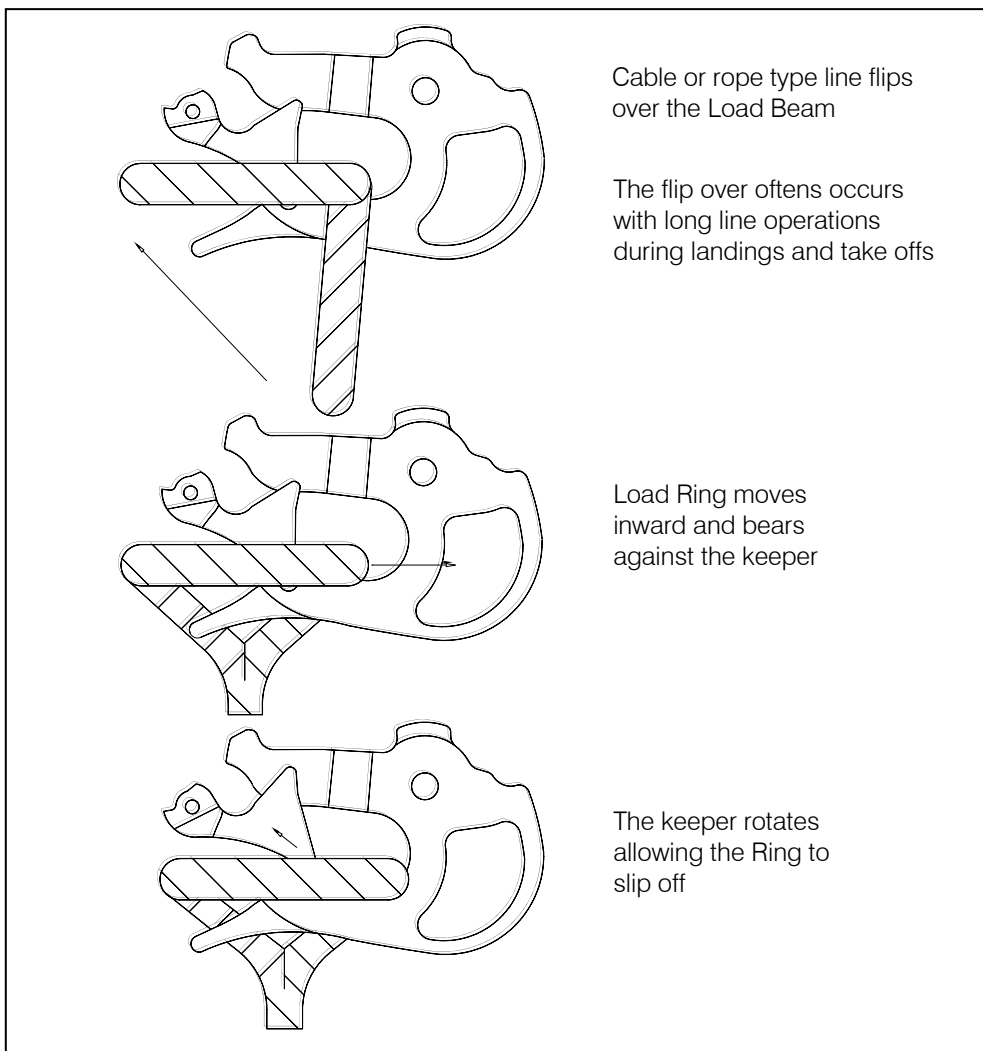

This page intentionally left blank.

Section 4

Maintenance

Storage Instructions

Clean the Cargo Hook thoroughly before packaging. Pack the unit in a heat-sealable package. If the unit is to be stored for long periods in a tropical climate it should be packed in a reliable manner to suit local conditions. Refer to relevant MIL specifications. After the Cargo Hook has been repaired or stored for an extended period of time it must be subjected to the Acceptance Test Procedure per service manual 122-002-00.

Package the unit in a suitable fiberboard box and cushion the unit to prevent shifting. Seal the fiberboard box with tape and mark the box with the contents and date of packaging.

Preventive Maintenance

Remove caked-on dirt from the Cargo Hook with a brush and clean exposed surfaces with a mild solvent. Thoroughly dry all surfaces.

Inspection

The scheduled inspection intervals noted below are maximums and are not to be exceeded. If the cargo hook is subjected to unusual circumstances, extreme environmental conditions, etc., it is the responsibility of the operator to perform the inspections more frequently to ensure proper operation.

Annually or 100 hours of external load operations, whichever comes first, inspect the cargo hook kit per the following.



Hours of external load operations is defined as the time in which a helicopter is engaged in external load operations. This includes time between loads on the hook.

1. Activate the helicopter electrical system and press the cargo release button to ensure the cargo hook electrical release is operating correctly. The cargo hook must release. If the hook does not release or re-latch, do not use the unit until the problem is corrected.

CAUTION

Pressing the cargo electrical release button continuously in excess of 20 seconds will cause the cargo hook electrical release solenoid to overheat, possibly causing permanent damage.

2. Activate the manual release system by pulling the release handle in the cockpit. The cargo hook must release. If the hook does not release or re-latch, do not use the unit until the problem is corrected.
3. Move the cargo hook throughout its full range of motion to ensure the manual and electrical release cables have enough slack. The cables must not be the stops that prevent the cargo hook from moving freely in all directions.
4. Visually check for presence and security of fasteners and electrical connections.
5. Visually inspect the manual release cable for damage, paying close attention to the flexible conduit at the area of transition to the cargo hook end fitting (refer to Figure 4-1). Inspect for splitting of the outer black conduit and heat shrink in this area and separation of the conduit from the steel end fitting.

Figure 4-1 Manual Release Cable Inspection

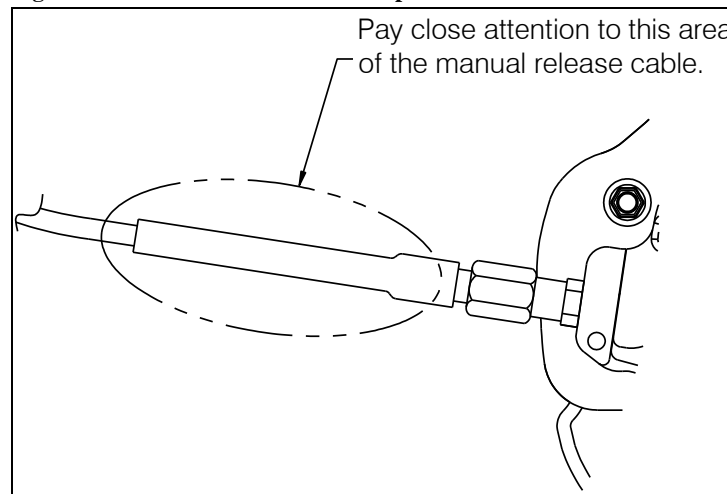

Inspection continued

6. Visually inspect for corrosion on the exterior of cargo hook and suspension system components. Corrosion on the cargo hook side plates is cause for immediate overhaul. Additionally, any exfoliation corrosion in the upper attach lug area of the cargo hook is cause for immediate replacement of the side plate. Refer to the Cargo Hook Service Manual 122-002-00 for instructions

Adapter Link Overhaul

Time Between Overhaul (TBO): 1000 hours of external load operations or 5 years, whichever comes first.

Refer to Service Manual 122-002-00 for overhaul information for the Cargo Hook.

Remove adapter link from the helicopter and inspect per the following instructions (refer to Figure 4-2 for parts breakdown).

- Inspect the bushing ID surfaces for wear and corrosion. Pitting, corrosion or excessive wear is cause for rejection. Maximum permissible bushing clearance is .010" on diameter. If bushing P/N 290-364-00 needs to be replaced, press in new bushing with wet zinc chromate primer.
- Inspect the link for damage. Repair dents, gouges, nicks, scratches and corrosion if less than .030" deep, blend out at a ratio of 20:1, length to depth, replace Adapter Link Assembly if otherwise damaged.
- Perform Magnetic Particle Inspection on adapter link P/N 290-363-00 in accordance with ASTM E-1444 and MIL-STD-1907, Grade A. No cracks are permitted.

Figure 4-2 Link Assembly Parts

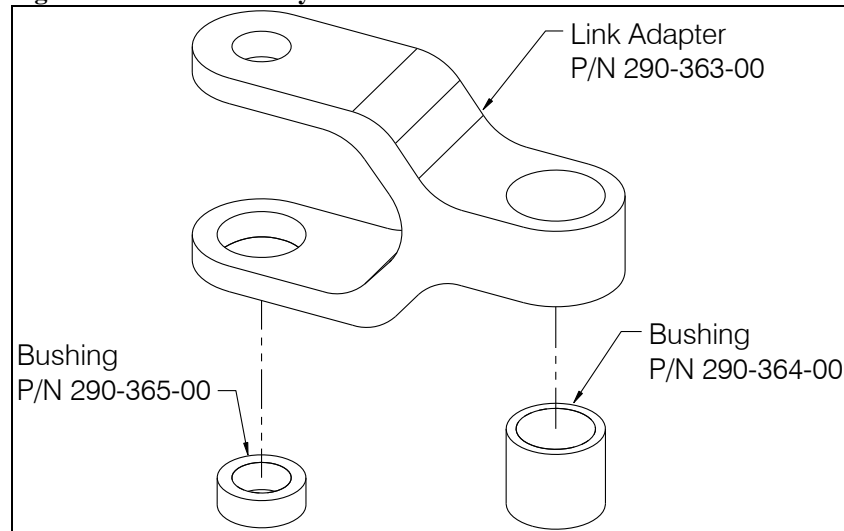

Instructions for Returning Equipment to the Factory

If an Onboard Systems product must be returned to the factory for any reason (including returns, service, repairs, overhaul, etc) obtain an RMA number before shipping your return.



An RMA number is required for all equipment returns.

- To obtain an RMA, please use one of the listed methods.
 - Contact Technical Support by phone or e-mail (Techhelp@OnboardSystems.com).
 - Generate an RMA number at our website: <http://www.onboardsystems.com/rma.php>
- After you have obtained the RMA number, please be sure to:
 - Package the component carefully to ensure safe transit.
 - Write the RMA number on the outside of the box or on the mailing label.
 - Include the RMA number and reason for the return on your purchase or work order.
 - Include your name, address, phone and fax number and email (as applicable).
 - Return the components freight, cartage, insurance and customs prepaid to:
Onboard Systems
13915 NW 3rd Court
Vancouver, Washington 98685
USA
Phone: 360-546-3072

Section 5 Certification

STC

United States of America
Department of Transportation—Federal Aviation Administration
Supplemental Type Certificate

Number SR00538SE

This certificate, issued to

**Onboard Systems
11212 NW St. Helens Road
Portland, OR 97231**

certifies that the change in the type design for the following product with the limitations and conditions therefor as specified hereon meets the airworthiness requirements of Part 6 of the Civil Air Regulations.

Original Product—Type Certificate Number: H2SW
Make: Bell
Model: 206A and 206B

Description of the Type Design Change: Fabrication of Onboard Systems Model 200-232-00 cargo hook kit in accordance with FAA Approved Onboard Systems Master Drawing List No. 155-039-00, dated June 26, 2000, or later FAA approved revision; and installation of this replacement cargo hook in accordance with FAA approved Onboard Systems Owner's Manual No. 120-074-00, dated June 26, 2000, or later FAA approved revision. Inspect this cargo hook kit in accordance with Onboard Systems Service Manual No. 122-002-00, dated June 12, 2000, or later FAA approved revision.

Limitations and Conditions: Approval of this change in type design applies to only those Bell model rotorcraft listed above, which were previously equipped with an FAA approved installation of Bell cargo hook suspension assembly, P/N 206-706-335-1, -101, or -103; Bell cargo hook provisions kit, P/N 206-706-335-3, -5 or -105; and Breeze Eastern cargo hook P/N SP-4232-4, -5, or -5L. This approval should not be extended to helicopters of these models on which other previously approved modifications are incorporated unless it is determined by the installer that the relationship between this change and any of those other previously approved modifications, including changes in type design, will introduce no adverse effect upon the airworthiness of that helicopter. Modified rotorcraft must be operated in accordance with an FAA approved copy of Onboard Rotorcraft Flight Manual Supplement (RFMS) No. 120-074-00, dated July 27, 1998, or later FAA approved revision.

See Continuation Sheet, Page 3 of 3

This certificate and the supporting data which is the basis for approval shall remain in effect until surrendered, suspended, revoked, or a termination date is otherwise established by the Administrator of the Federal Aviation Administration.

Date of application: May 28, 1998

Date of issuance: July 27, 1998

Date reissued:

Date amended: July 27, 2000

By direction of the Administrator



(Signature)

Acting Manager, Seattle Aircraft
Certification Office

(Title)



Any alteration of this certificate is punishable by a fine of not exceeding \$1,000, or imprisonment not exceeding 3 years, or both.

This certificate may be transferred in accordance with FAR 21.47.

FAA FORM 8110-2(10-68)

United States of America
Department of Transportation—Federal Aviation Administration
Supplemental Type Certificate
(Continuation Sheet)

Number SR00538SE

Limitations and Conditions continued:

A copy of this Certificate and the RFMS must be maintained as part of the permanent records of the modified helicopter.

If the holder agrees to permit another person to use this certificate to alter the product, the holder shall give the other person written evidence of that permission.

- END -

Any alteration of this certificate is punishable by a fine of not exceeding \$1,000, or imprisonment not exceeding 3 years, or both.

FAA FORM 8110-2-1 (10-69)

This certificate may be transferred in accordance with FAR 21.47.

PAGE 3 OF 3 PAGES

STA



Transport Canada Transports Canada

Department of Transport

Supplemental Type Certificate

This approval is issued to:

Onboard Systems
11212 NW St. Helens Road
Portland, OREGON
97231 UNITED STATES OF AMERICA

Number: SH98-48

Issue No.: 2

Approval Date: September 14, 1998

Issue Date: October 24, 2000

Responsible Office: Pacific

Aircraft/Engine Type or Model: Bell 206A, and 206B

Canadian Type Certificate or Equivalent: H-92

Description of Type Design Change: Fabrication and Installation of Onboard Systems Cargo Hook Kit per FAA STC SR00538SE

Installation/Operating Data,
Required Equipment and Limitations:

Fabrication of Onboard Systems Model 200-232-00 Cargo Hook Kit in accordance with FAA approved Onboard Systems Master Drawing List No. 155-039-00, dated June 26, 2000, or later FAA approved revisions; and, **Installation** of this system in accordance with FAA approved Onboard Systems Owner's Manual No. 120-074-00, dated June 20, 2000, or later FAA approved revisions. **Inspect** cargo hook kit in accordance with Onboard Systems Service Manual No. 122-002-00, dated June 20, 2000, or later FAA approved revisions.

Basis of Certification as defined in the applicable Type Certificate Data Sheets.

Rotorcraft equipped with the Onboard Systems Model 200-232-00 Cargo Hook Kit must be operated in accordance with FAA approved Rotorcraft Flight Manual Supplement (RFMS) No. 120-074-00, dated July 27, 1998, or later FAA approved revisions.

Approval of this change in type design applies to only those Bell model rotorcraft listed above, which were equipped with an FAA approved installation of Bell Cargo Hook Suspension Assembly, P/N 206-706-335-1, -101, or -103; Bell Cargo Hook Provisions Kit, P/N 206-706-335-3, -5 or -105; and Breeze Eastern Cargo Hook P/N SP-4232-4, -5, or -5L.

-- End --



Conditions: This approval is only applicable to the type/model of aeronautical product specified therein. Prior to incorporating this modification, the installer shall establish that the interrelationship between this change and any other modification(s) incorporated will not adversely affect the airworthiness of the modified product.

H. W. Wong
Aircraft Certification Engineer
For Minister of Transport

Canada

This page intentionally left blank.

FAA APPROVED

ROTORCRAFT FLIGHT MANUAL SUPPLEMENT

**Bell Helicopter Models
206A & 206B**

R/N _____

S/N _____

FAA Approved:



Manager, Special Certification Branch
Seattle Aircraft Certification Office

Date:

July 27, 1998

Revised:



Rotorcraft Flight
Manual Supplement

Document Number

120-074-00

Cargo Hook

Page

1

INTRODUCTION

This supplement must be attached to the appropriate approved Bell Rotorcraft Flight Manual when an Onboard Systems 200-232-00 Cargo Hook Kit is installed in accordance with Supplemental Type Certificate (STC) NO. SR00538SE. The information contained herein supplements or supersedes the basic manual only in those areas listed herein. For limitations, procedures and performance information not contained in this supplement, consult the basic Rotorcraft Flight Manual.

I. LIMITATIONS

The basic Flight Manual remains applicable. When an Onboard Systems 200-232-00 Cargo Hook Kit is installed, the following placard applies:

- Mounted on bottom of Cargo Hook.

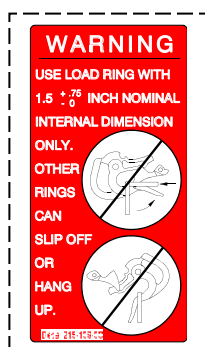

II. PERFORMANCE

The basic Flight Manual and Bell Rotorcraft Flight Manual Supplement-Cargo Hook remains applicable.

III. PROCEDURES

Before each Cargo Hook use perform the following procedures. If the procedures are not successful do not use the equipment until the problem has been corrected.

- Inspect all mounting fasteners to ensure that they are tight.
- Visually inspect the electrical connector for loose or damaged pins and sockets.
- Operate the keeper manually and check that it snaps back to its normal position on the load beam.
- Inspect the case and covers for cracks and damage.
- Inspect the load beam for gouges and cracks.
- Cycle the manual release mechanisms to ensure proper operation.
- Cycle the electrical release mechanisms to ensure proper operation.



Rotorcraft Flight
Manual Supplement

Document Number

120-074-00

Cargo Hook

Page

2

III. PROCEDURES, continued

Cargo Hook Rigging

Extreme care must be exercised in rigging a load to the Cargo Hook. If the load ring is too big it may work its way around the end of the load beam and be supported for a time on the keeper and then fall free. If the load ring is too small it may jam itself against the load beam during an attempted release. The following illustrations show recommended configurations and potential difficulties that must be avoided.

WARNING: The examples shown are not intended to represent all problem possibilities. It is the responsibility of the operator to assure the hook will function properly with the rigging.

Figure 1 Examples of correct and incorrect cargo hook rigging

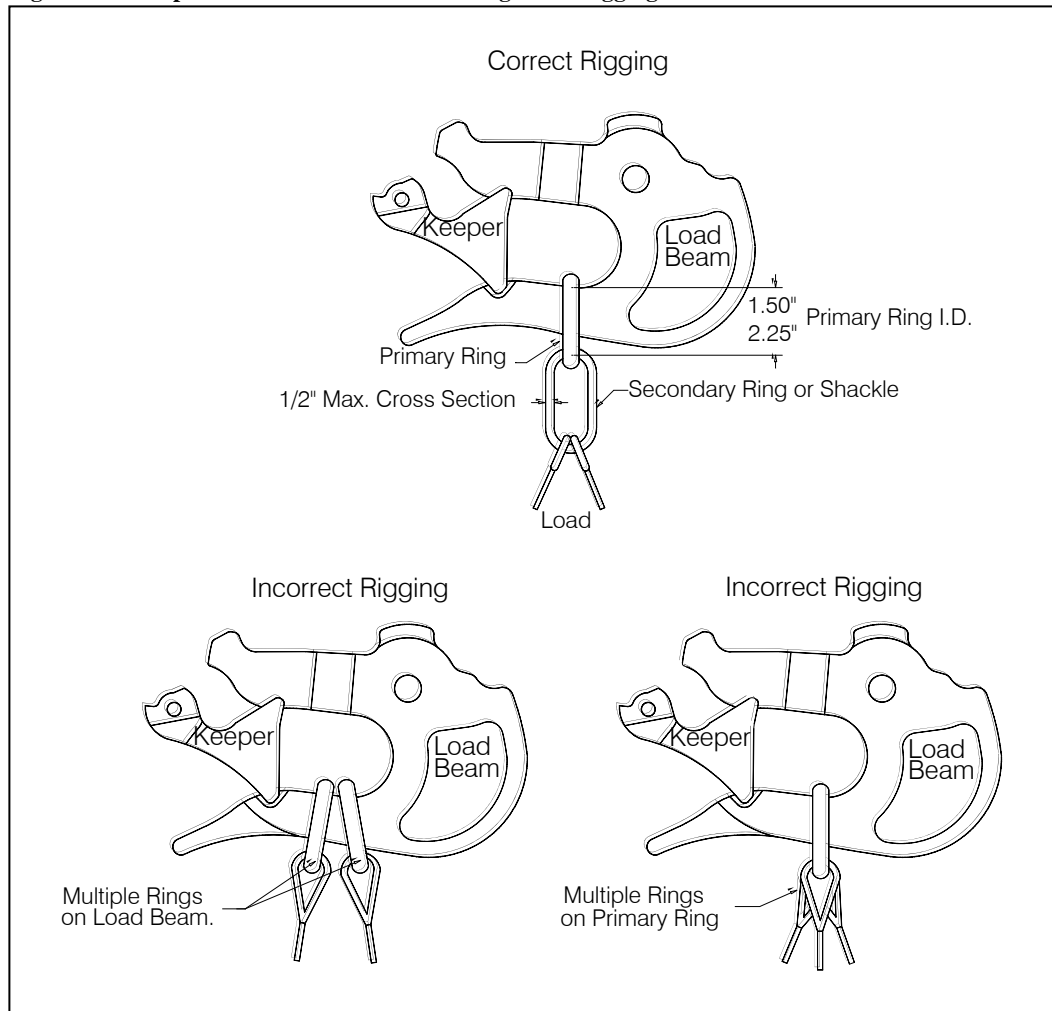

III. PROCEDURES, continued

Un-Commanded Release Due to Too Large of a Load Ring

WARNING: Load rings that are too large will cause an un-commanded release. The ring will flip over the end of the load beam and flip the keeper up and then fall free. Only correctly sized load rings must be used. See examples below.

Figure 2 Un-commanded release due to load rings that are too large

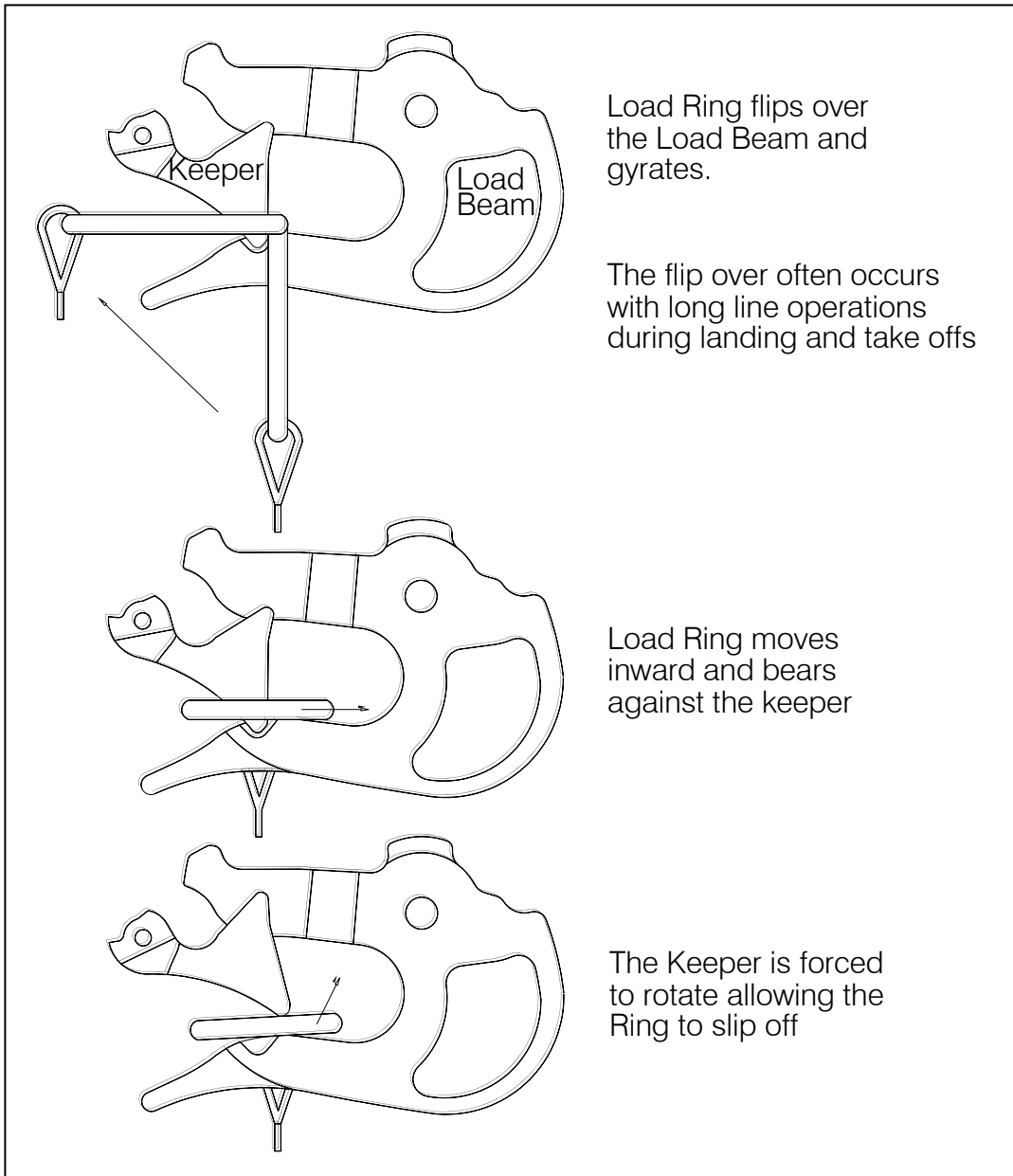

III. PROCEDURES, continued

Load Hang-Up Due to Too Small of a Load Ring or Multiple Load Rings

WARNING: Load rings that are too small or multiple load rings will hang on the load beam when the load is released. Only correctly sized load rings must be used. See examples below.

Figure 3 Load hang-up due to load rings that are too small or using multiple load rings

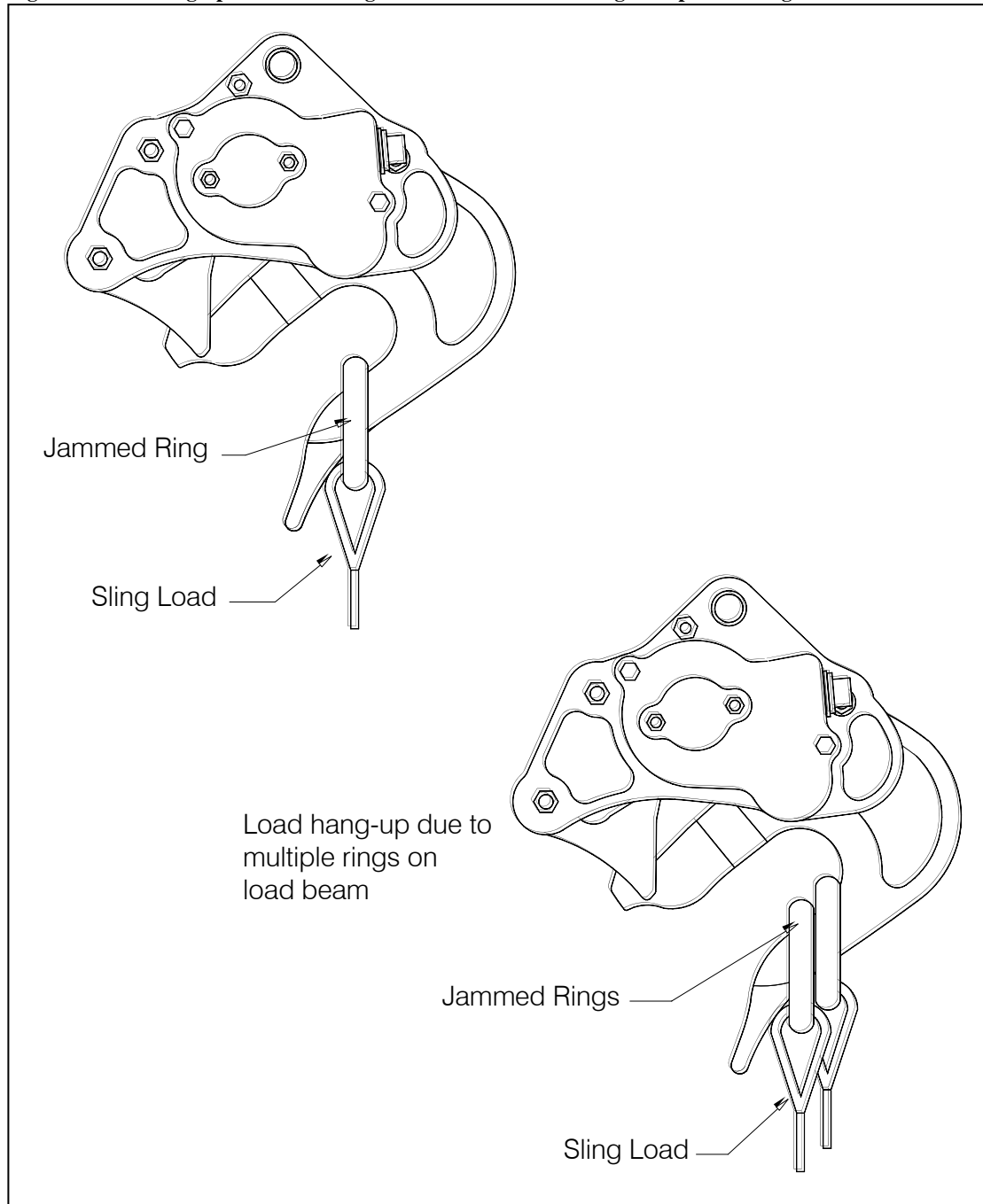

III. PROCEDURES, continued

Un-Commanded Release Due to Nylon Type Straps

WARNING: Nylon type straps (or similar material) must not be used directly on the cargo hook load beam as they have a tendency to creep under the keeper and fall free. If nylon straps must be used they should first be attached to a correctly sized primary ring. Only the primary ring should be in contact with the cargo hook load beam. See examples below.

Figure 4 Un-commanded release due to nylon type straps

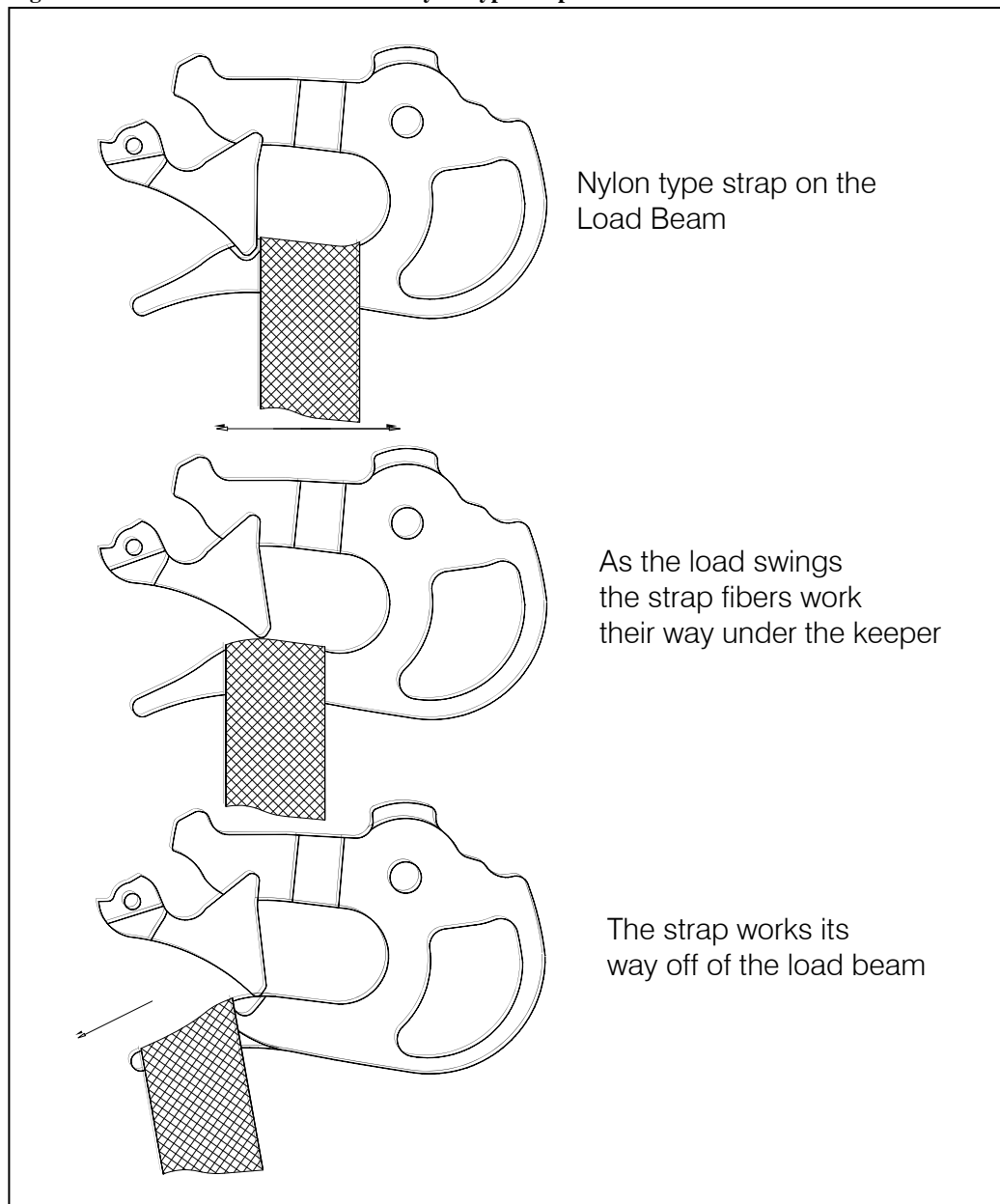

III. PROCEDURES, continued

Un-Commanded Release Due to Cable or Rope Type Straps

WARNING: Cable or rope type straps must not be used directly on the cargo hook load beam. Their braided eyes will work around the end of the load beam and fall free. If cable or rope is used they should first be attached to a correctly sized primary ring. Only the primary ring should be in contact with the cargo hook load beam. See examples below.

Figure 5 Un-commanded release due to cable or rope type straps

