

**PLEASE CHECK WEB SITE AT [WWW.ONBOARDSYSTEMS.COM](http://WWW.ONBOARDSYSTEMS.COM) FOR  
THE LATEST REVISION OF THIS MANUAL**

## **Cargo Hook Kit**

*For*  
**Schweizer 269C**

**Part Number 200-244-00**

**Owner's Manual**

*Owner's Manual Number 120-081-00*  
*Revision 5*  
*October 18, 2007*



*13915 NW 3<sup>rd</sup> Court Vancouver, Washington 98685 USA*  
*Phone: 360-546-3072 Fax: 360-546-3073 Toll Free: 800-275-0883*  
*[www.OnboardSystems.com](http://www.OnboardSystems.com)*

This page intentionally left blank.

## RECORD OF REVISIONS

<i>Revision</i>	<i>Date</i>	<i>Page(s)</i>	<i>Reason for Revision</i>
1	6/16/01	Section 4	Removed overhaul instructions from Section 4 and moved information to the new Service Manual 122-001-00
2	7/16/01	2-2, 3-5 RFMS pg 5	Replaced hook picture to show new cover and S/N plate (P/N 215-154-00).
3	09/05/06	3-1, Section 4	Updated cargo hook kit maintenance information.
4	02/13/07	1-1, 2-2 & 4-1	Changed Cargo Hook P/N 528-010-00 to 528-010-04 (ref. service bulletin 159-017-00).
5	10/18/07	TOC, Section 1, 2-4, Section 3	Added explanation of warnings, cautions and notes to Section 1. Updated warnings, cautions and notes throughout document.

### **Register Your Products for Automatic Notifications**

Onboard Systems offers a free notification service via fax or email for product alerts and documentation updates. By registering your Onboard Systems products at our website, we will be able to contact you if a service bulletin is issued, or if the documentation is updated.

You can choose to receive notices on an immediate, weekly, or monthly schedule via fax, email or both methods. There is no charge for this service. Please visit our website at [www.onboardsystems.com/notify.php](http://www.onboardsystems.com/notify.php) to get started.

This page intentionally left blank.

# ***CONTENTS***

## ***Section 1*** **General Information**

Introduction, 1-1  
Warnings, Cautions and Notes, 1-1  
Bill of Materials, 1-2  
Inspection, 1-2  
Specifications, 1-3  
Theory of Operation, 1-3

## ***Section 2*** **Installation Instructions**

Cargo Hook Removal, 2-1  
Cargo Hook Installation, 2-1  
Secure the Release Cables, 2-4  
Installation Check-Out, 2-5  
Component Weights, 2-5  
Paper Work, 2-5

## ***Section 3*** **Operation Instructions**

Operating Procedures, 3-1  
Cargo Hook Rigging, 3-2  
Cargo Hook Rigging Illustrations, 3-3

## ***Section 4*** **Maintenance**

Inspection, 4-1  
Instructions for Returning a System to the Factory, 4-2

## ***Section 5*** **Certification**

STC, 5-1  
Canadian STC, 5-2  
EASA STC, 5-3  
Rotorcraft Flight Manual Supplement

# ***CONTENTS, continued***

## ***Figures***

- 2-1 Travel Limit Bumper Installation, 2-1
- 2-2 Attach Hardware Installation, 2-2
- 2-3 Bumper Pads, 2-2
- 2-4 Manual Release Cable Rig, 2-3
- 2-5 Un-commanded Release From Incorrectly Secured Cable, 2-4
- 2-6 Installation Overview, 2-4
- 3-1 Examples of Correct and Incorrect Cargo Hook Rigging, 3-3
- 3-2 Un-commanded Release Due to Large Load Ring, 3-4
- 3-3 Load Hang-Up, Too Small or Multiple Load Rings, 3-5
- 3-4 Un-Commanded Release Due to Nylon Straps, 3-6
- 3-5 Un-Commanded Release Due to Cable or Rope Straps, 3-7

## ***Tables***

- 1-1 Specifications, 1-2
- 2-1 Component Weight, 2-5
- 4-1 Inspection, 4-1

# *Section 1*

## **General Information**

### **Introduction**

The 200-244-00 Schweizer 269C Cargo Hook Kit is approved for installation with the following Schweizer Cargo Hook Kits.

269A4971-27

### **Warnings, Cautions and Notes**

The following definitions apply to Warnings, Cautions and Notes used in this manual.



*Means that if this information is not observed, serious injury, death or immediate loss of flight safety could occur.*



*Means that there is a risk of injury or degradation in performance of equipment if this information is not observed.*



*Draws the reader's attention to information which may not be directly related to safety, but which is important or unusual.*

## Bill of Materials

The following items are included with the Cargo Hook Kit, if shortages are found contact the company from whom the system was purchased.

<b>Part Number</b>	<b>Description</b>	<b>Quantity</b>
528-010-04	Cargo Hook	1
290-331-00	Release Fitting	1
290-364-00	Bushing	1
510-318-00	Bolt	1
517-029-00	Spacer	1
510-100-00	Washer	1
510-227-00	Nut	1
510-319-00	Bolt	1
290-548-00	Adapter Bushing	1
510-239-00	Washer	2
510-320-00	Nut	1
510-115-00	Cotter Pin	1
270-093-00	Electrical Release Wire Harness	1
120-081-00	Owners Manual	1

## Inspection

Inspect the kit items for evidence of damage, corrosion and security of lock wire and fasteners. If damage is evident, do not use the items until they are repaired.



# Specifications

**Table 1-1 Cargo Hook Specifications**

Design load	3,500 lb. (1,587 kg.)
Design ultimate strength	15,750 lb. (7,142 kg.)
Electrical release capacity	8,750 lb. (3,968 kg.)
Mechanical release capacity	8,750 lb. (3,968 kg.)
Force required for mechanical release at 3,500 lb.	8 lb. Max.(.400” travel)
Electrical requirements	22-28 VDC 9 amps
Minimum release load	7 pounds
Unit weight	3 pounds (1.36 kg.)
Mating electrical connector	PC06A8-2S SR

## Theory of Operation

The primary elements of the Cargo Hook are the load beam, the internal mechanism, and a DC solenoid. The load beam supports the load and is latched through the internal mechanism. The DC solenoid and an external manual release cable provide the means for unlatching the load beam.

The load beam is normally returned to its closed position after release of the load by a spring in the internal mechanism. In the closed position, a latch engages the load beam and latches it in this position. The load is attached to the load beam by passing the cargo sling ring into the throat of the load beam past a spring-loaded keeper, which secures the load.

To release the load, the latch is disengaged from the load beam. With the latch disengaged, the weight of the load causes the load beam to swing to its open position, and the cargo sling slides off the load beam. A spring in the internal mechanism then drives the load beam back to its closed and latched position.

A load release can be initiated by three different methods. Normal release is achieved by pilot actuation of the push-button switch in the cockpit. When the push-button switch is pressed, it energizes the DC solenoid in the Cargo Hook, and the solenoid opens the latch in the internal mechanism. In an emergency, release can be achieved by operating a mechanical release lever. A manual release cable attached to the lever operates the internal mechanism of the Cargo Hook to unlatch the load beam. The load can also be released by the actuation of a lever located on the side of the cargo hook.

This page intentionally left blank.

## ***Section 2***

# **Installation Instructions**

These procedures are provided for the benefit of experienced aircraft maintenance facilities capable of carrying out the procedures. They must not be attempted by those lacking the necessary expertise.

### **Cargo Hook Removal**

Remove the Schweizer supplied Cargo Hook from the aircraft by disconnecting the electrical release cable from the belly mounted bulk-head type connector. Disconnect the manual release cable from the cargo hook. Remove the NAS1305-26D bolt, AN310-5 nut and cotter pin used to attach the Cargo Hook to the suspension system mounting brackets. Remove the cargo hook from the mounting brackets. Also at this time remove the NAS1304-24 upper bolt, NAS43HT4-81 spacer and MS21042-4 nut from the suspension system mounting brackets.

### **Cargo Hook Installation**

Verify that the part number of the cargo hook removed is a Breeze-Eastern 2A20B P/N 17149-4. If it is not, do not attempt to use the new cargo hook unless compatibility is determined.

Inspect the suspension system mounting brackets and attaching hardware to insure that all components are in serviceable condition.

Install the new Cargo Hook to the existing Schweizer suspension system mounting brackets using the hardware supplied with the new hook, as illustrated in Figure 2-1. The cargo hook load beam is to point aft.

# Cargo Hook Installation, continued

Figure 2-1 Attach Hardware Installation

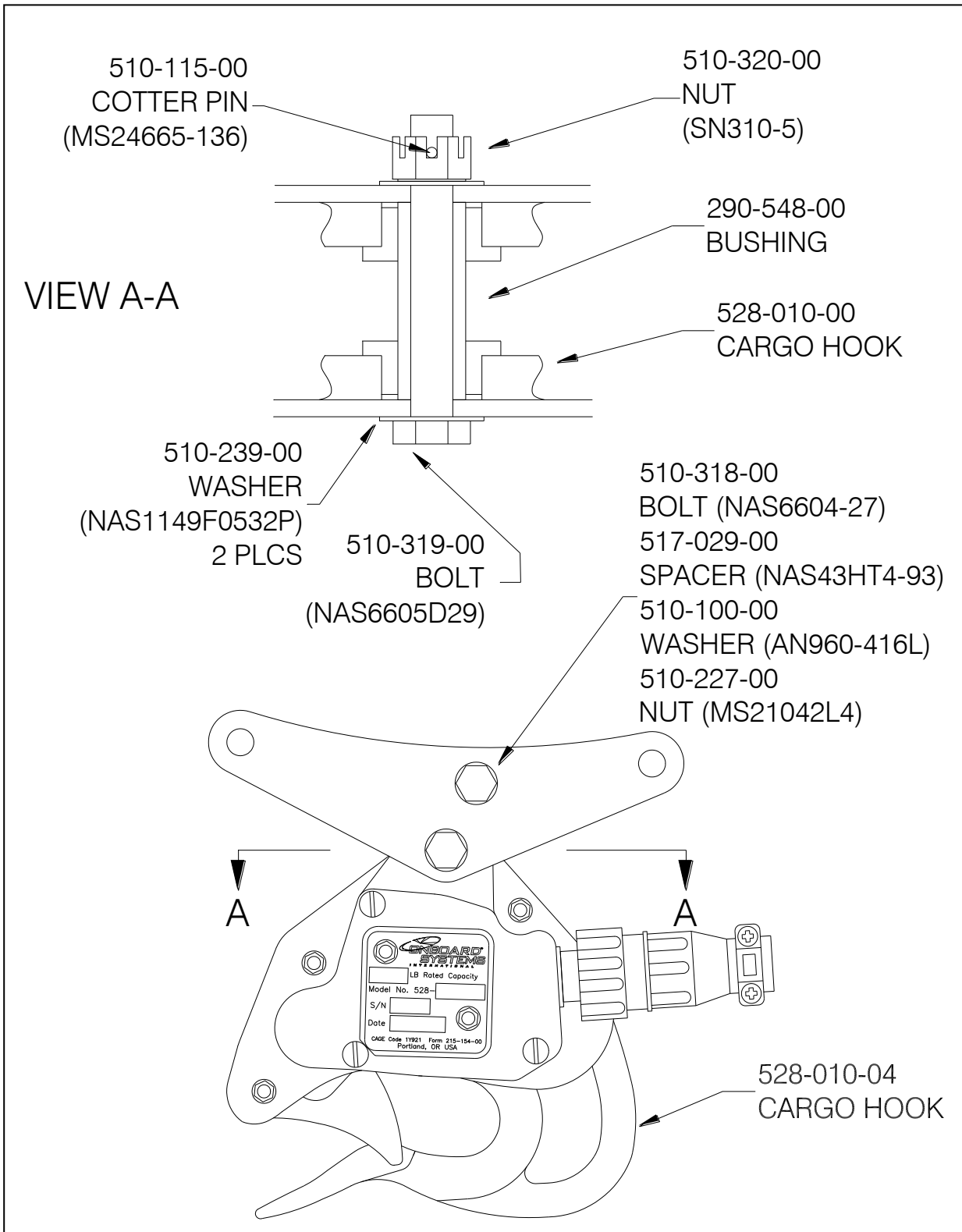

## Cargo Hook Installation, continued

Connect the manual release cable to the Cargo Hook by first removing the cargo hook manual release cover. Locate the swaged end of the manual release cable assembly, the other end is the cable adjuster. Thread the swaged end of the manual release cable all the way into the hook and tighten against the hook. Place the cable ball end fitting into the hook manual release fork fitting as illustrated in Figure 2-2.

Figure 2-2 Manual Release Cable Rig

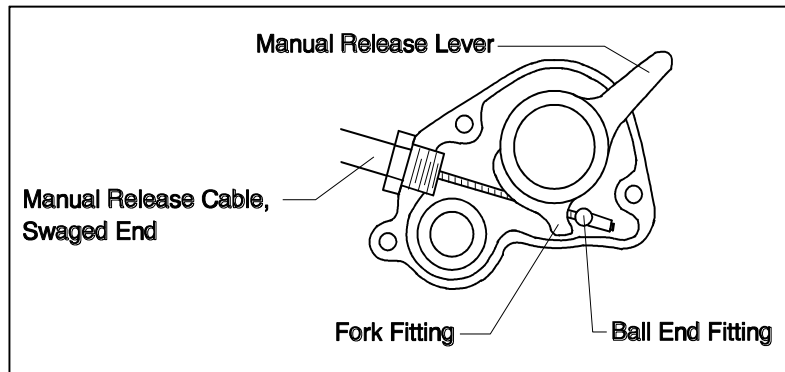

Connect the Cargo Hook electrical release cable harness connector to the cargo hook and the belly mounted bulk-head receptacle and safety wire the connector.

Listed below is the pin out for the cargo hook and the bulkhead connector.

### Cargo Hook Connector

Pin	Function
A	Ground
B	Power

### Bulkhead Connector

Pin	Function
A	Power
B	Ground
C	Not used

## Secure the Release Cables



*Un-commanded cargo hook release will happen if the manual and electrical release cables are improperly restrained. The cables must not be the stops that prevent the Cargo Hook from swinging freely in all directions. If the Cargo Hook loads cause the hook to strain against the manual release cable the swaged end of the cable may separate allowing the inner cable to activate the cargo hook manual release mechanism. The result is an un-commanded release. Ensure that no combination of cyclic stick or Cargo Hook position is restrained by the manual or electrical release cables.*

**Figure 2-3 Un-commanded Release From Incorrectly Secured Cable**

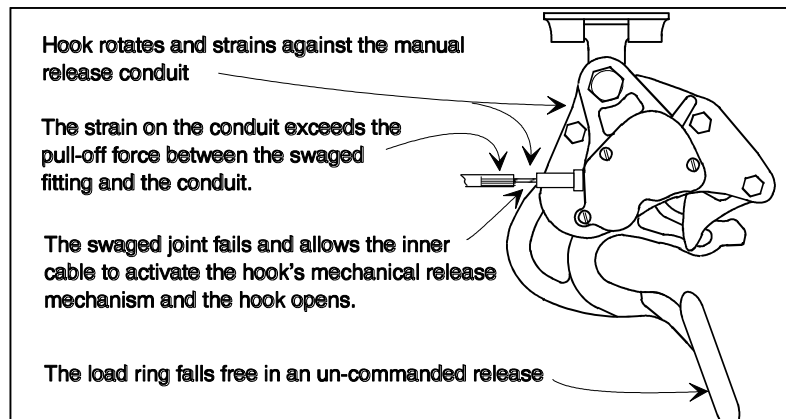

## Installation Check-Out

After installation of the Cargo Hook, perform the following functional checks.

1. Swing the installed Cargo Hook. Ensure that the manual release cable assembly and the electrical release cable have enough slack to allow full swing of the suspension assembly without straining or damaging the cables. The cables must not be the stops that prevent the Cargo Hook from swinging freely in all directions.
2. Apply 10 - 20 pounds to the cargo hook load beam and squeeze the lever operated cargo hook mechanical release, the cargo hook should release.
3. Close the cargo hook release circuit breaker and position the battery switch to the ON position. Apply 10 - 20 pounds to the cargo hook load beam and depress the cargo hook electrical release button, the cargo hook should release.
4. See the Schweizer service instructions for your specific helicopter model for additional installation instructions.

## Component Weights

The weight of the cargo hook components are listed in Table 2-1.

**Table 2-1 Component Weight**

Item	Weight lbs (kgs)
Cargo Hook	3.0 (1.36)
Electrical Release Cable	0.5 (.23)

## Paper Work

Remove the Flight Manual Supplement from the back of this manual and place it into the Rotorcraft Flight Manual. In the US, fill in FAA form 337 for the initial installation. This procedure may vary in different countries. Make the appropriate aircraft log book entry.

This page intentionally left blank.



# Section 3

## Operation Instructions

### Operating Procedures

Prior to each job perform the following:

1. Ensure that the Cargo Hook has been properly installed and that the manual and electrical release cables do not limit the movement of the hook.
2. Be completely familiar with this manual, particularly the Cargo Hook rigging section.
3. Be completely familiar with all Schweizer cargo hook operating instructions.
4. Activate the electrical system and press the release button to ensure the cargo hook electrical release is operating correctly. The mechanism should operate smoothly and the Cargo Hook must relatch after release. If the hook does not relatch do not use the unit until the difficulty is resolved.



*The release solenoid is intended to be energized only intermittently. Depressing the electrical release button continuously in excess of 20 sec. will cause the release solenoid to overheat, possibly causing permanent damage.*

5. Activate the release lever assembly located on the cyclic stick to test the cargo hook manual release mechanism. The mechanism should operate smoothly and the Cargo Hook must relatch after release. If the hook does not relatch do not use the unit until the difficulty is resolved.

See the Cargo Hook Service Manual 122-001-00 and the aircraft's service instructions that cover the original Cargo Hook installation for additional instructions.

## Cargo Hook Rigging

Extreme care must be exercised in rigging a load to the Cargo Hook. If the load ring is too big it may work its way around the end of the load beam and be supported for a time on the keeper and then fall free. If the load ring is too small it may jam itself against the load beam during an attempted release. The following illustrations show recommended configurations and potential difficulties that must be avoided.



*The examples shown are not intended to represent all problem possibilities. It is the responsibility of the operator to assure the hook will function properly with the rigging.*

# Cargo Hook Rigging, continued

Figure 3-1 Examples of Correct and Incorrect Cargo Hook Rigging

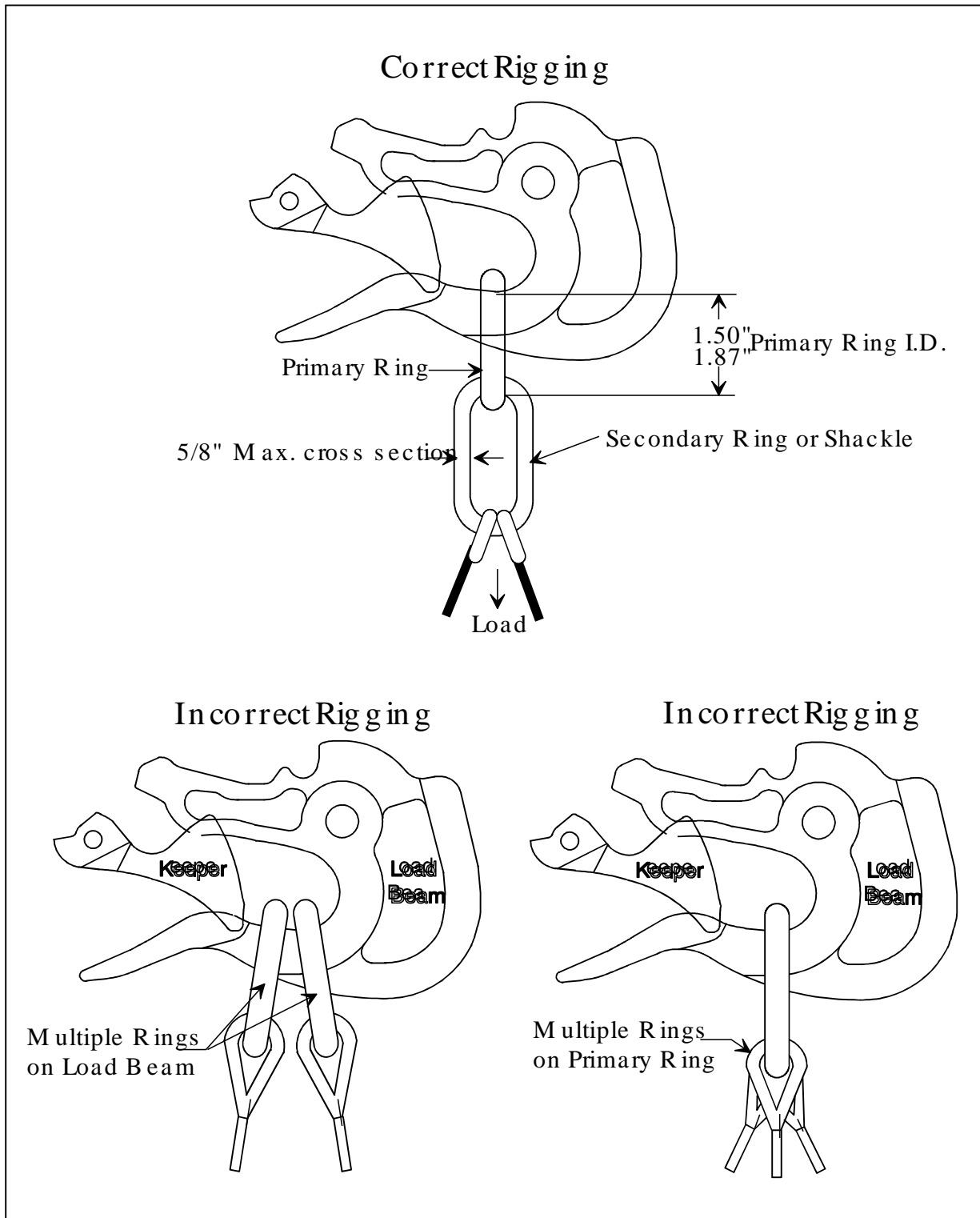

## Un-Commanded Release Due to Too Large of a Load Ring



*Load rings that are too large will cause an un-commanded release. The ring will flip over the end of the load beam and flip the keeper up and then fall free. Only correctly sized load rings must be used. See examples below.*

**Figure 3-2 Un-Commanded Release Due to Too Large of a Load Ring**

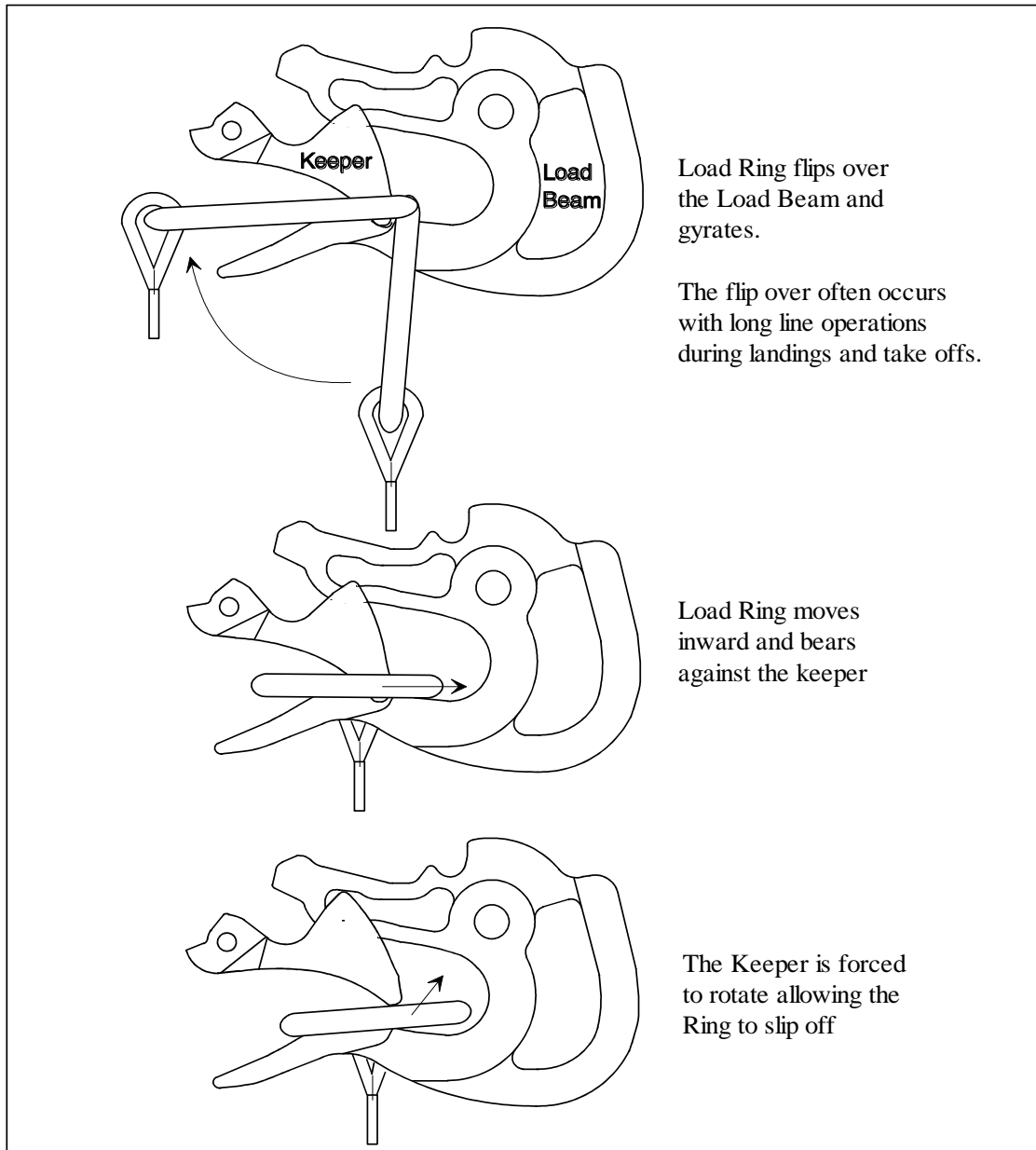

## Load Hang-Up Due to Too Small of a Load Ring or Multiple Load Rings



*Load rings that are too small or multiple load rings will hang on the load beam when the load is released. Only correctly sized load rings must be used. See examples below.*

**Figure 3-3 Load Hang-Up Due to Too Small a Load Ring or Multiple Load Rings**

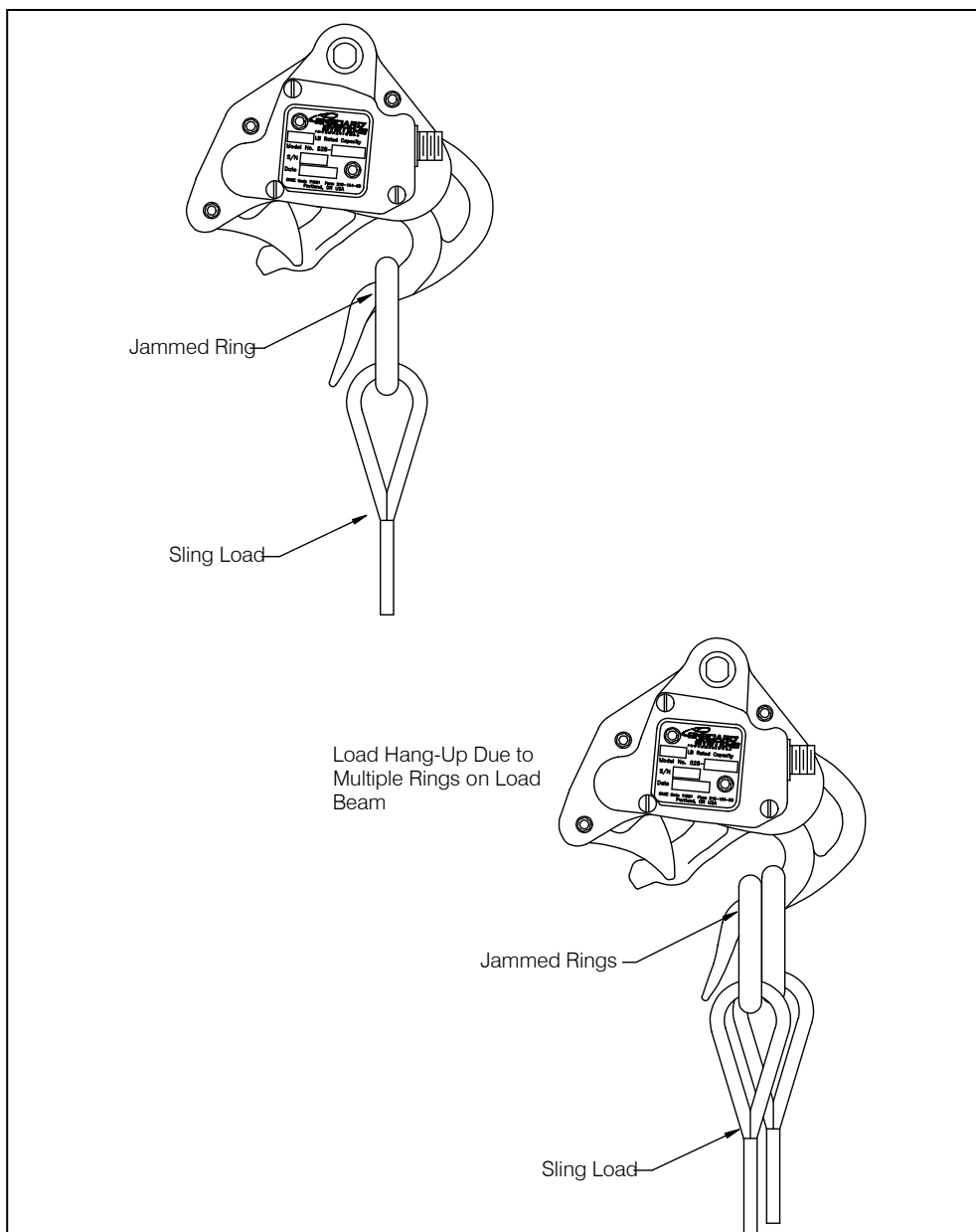

## Un-Commanded Release Due to Nylon Type Straps



*Nylon type straps (or similar material) must not be used directly on the cargo hook load beam as they have a tendency to creep under the keeper and fall free. If nylon straps must be used they should be first attached to a correctly sized primary ring. Only the primary ring should be in contact with the cargo hook load beam. See examples below.*

**Figure 3-4 Un-Commanded Release Due to Nylon Type Straps**

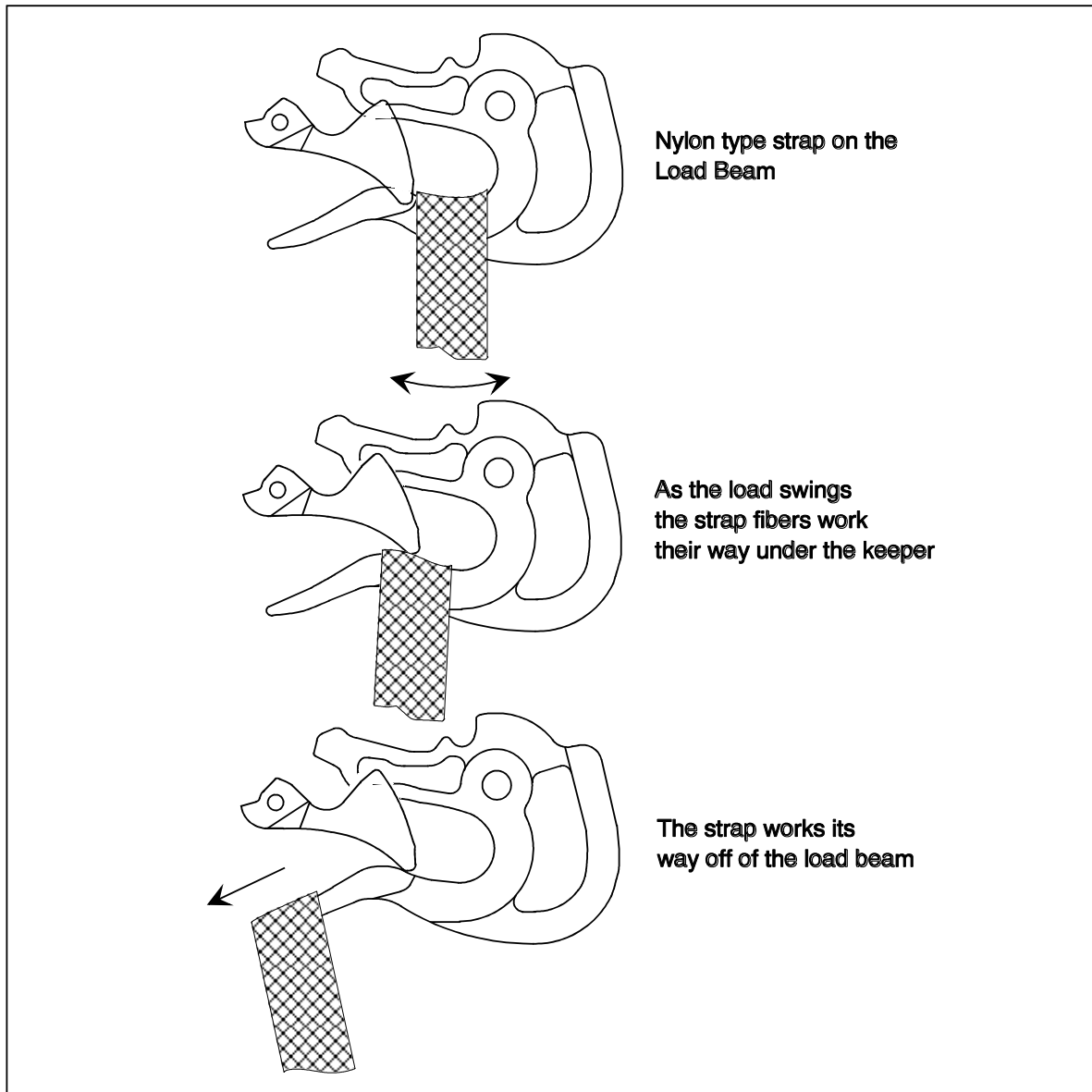

## Un-Commanded Release Due to Cable or Rope Type Straps



*Cable or rope type straps must not be used directly on the cargo hook load beam. Their braided eyes will work around the end of the load beam and fall free. If cable or rope is used they should be first attached to a correctly sized primary ring. Only the primary ring should be in contact with the cargo hook load beam. See examples below.*

**Figure 3-5 Un-Commanded Release Due to Cable or Rope Type Straps**

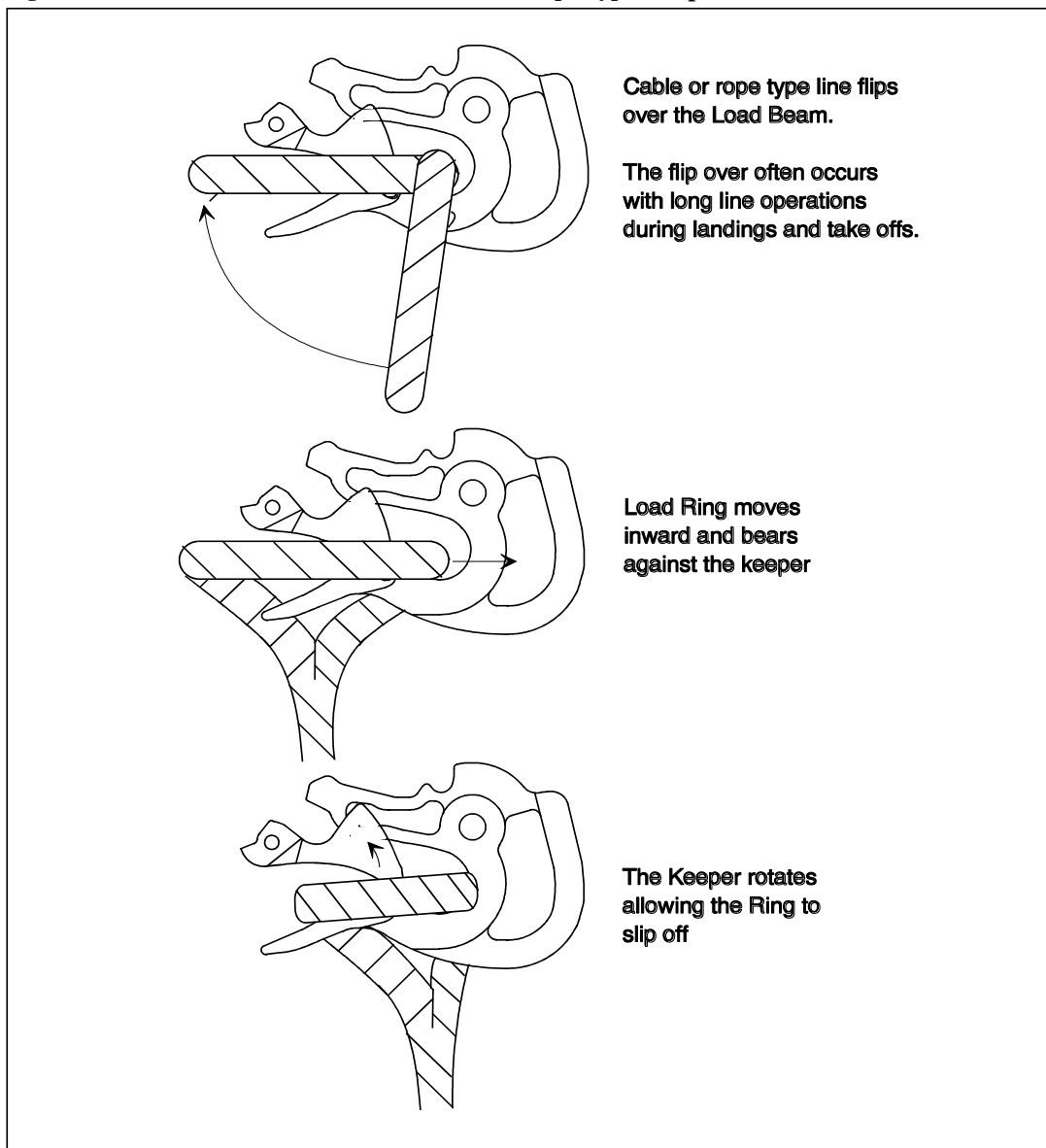

This page intentionally left blank.



# Section 4

## Maintenance

Refer to Component Maintenance Manual 122-001-00 for detailed maintenance information for the Cargo Hook.

### Inspection

The inspection of the Cargo Hook Kit shall be in accordance with the table below.

Table 4-1 Inspection

Part Number	Daily Check	At Overhaul Interval*
528-010-04 Cargo Hook	Refer to Service Manual 122-001-00.	Refer to Service Manual 122-001-00.
290-364-00 Bushing	Visually check for excessive wear.	Inspect to the requirements of this manual (see below) at cargo hook overhaul interval.
290-548-00 Adapter Bushing	Visually check for excessive wear.	Inspect to the requirements of this manual (see below) at cargo hook overhaul interval.
270-093-00 Electrical Release Wire Harness	1. Check for security of attachment, damaged wires and connectors. Replace if damaged.	Most system problems will be the result of damaged wires. Keep the cables clean and ensure that they are not chafing. Replace if the insulation or shield is damaged.
All fasteners	1. Inspect for cracks, excessive wear and security or attachment. If worn excessively or cracked, replace part.	Replace fasteners at cargo hook overhaul interval.

\* Refer to Service Manual 122-001-00 for overhaul interval for the Cargo Hook.

### Bushing Overhaul

Inspect the bushing and bearing surfaces for wear and corrosion. Pitting, corrosion or excessive wear is cause for rejection. Maximum permissible bushing clearance is .010" on diameter.

## Instructions for Returning Equipment to the Factory

If an Onboard Systems product must be returned to the factory for any reason (including returns, service, repairs, overhaul, etc.) obtain an RMA number before shipping your return.



*An RMA number is required for all equipment returns.*

- To obtain an RMA, please use one of the listed methods.
  - Contact Technical Support by phone or e-mail ([Techhelp@OnboardSystems.com](mailto:Techhelp@OnboardSystems.com)).
  - Generate an RMA number at our website: <http://www.onboardsystems.com/rma.php>
- After you have obtained the RMA number, please be sure to:
  - Package the component carefully to ensure safe transit.
  - Write the RMA number on the outside of the box or on the mailing label.
  - Include the RMA number and reason for the return on your purchase or work order.
  - Include your name, address, phone and fax number and email (as applicable).
  - Return the components freight, cartage, insurance and customs prepaid to:  
Onboard Systems International  
13915 NW 3rd Court  
Vancouver, Washington 98685  
USA  
Phone: 360-546-3072

# Section 5 Certification

## STC

United States of America  
Department of Transportation—Federal Aviation Administration  
**Supplemental Type Certificate**

*Number* SR00711SE

*This certificate, issued to* **Onboard Systems  
13915 NW 3rd Court  
Vancouver, WA 98685**

*certifies that the change in the type design for the following product with the limitations and conditions therefor as specified hereon meets the airworthiness requirements of Part 6 of the Civil Air Regulations.*

*Original Product—Type Certificate Number:* 4H12  
*Make:* Schweizer  
*Model:* 269C

*Description of the Type Design Change:* Fabrication of Onboard Systems Model 200-244-00 cargo hook kit in accordance with FAA approved Onboard Systems Master Drawing List No. 155-045-00, dated May 6, 1999, or later FAA approved revision; and installation of this replacement cargo hook in accordance with FAA approved Onboard Systems Owner's Manual No. 120-081-00, dated May 3, 1999, or later FAA approved revision. Inspect this cargo hook kit in accordance with Section 4 of Onboard Systems Owner's Manual No. 120-081-00, dated May 3, 1999, or later FAA approved revision.

*Limitations and Conditions:* Approval of this change in type design applies only to those Schweizer 269C which were previously equipped with an FAA approved installation of Schweizer cargo hook kit P/N 269A4971-27. This approval should not be extended to other rotorcraft of these models on which other previously approved modifications are incorporated unless it is determined by the installer that the relationship between this change and any of those other previously approved modifications, including changes in type design, will introduce no adverse effect upon the airworthiness of that rotorcraft. Modified rotorcraft must be operated in accordance with an FAA approved copy of Onboard Rotorcraft Flight Manual Supplement (RFMS) No. 120-081-00, dated June 30, 1999, or later FAA approved revision. A copy of this Certificate and FAA approved RFMS must be maintained as part of the permanent records of the modified rotorcraft.

If the holder agrees to permit another person to use this certificate to alter the product, the holder shall give the other person written evidence of that permission.

*This certificate and the supporting data which is the basis for approval shall remain in effect until surrendered, suspended, revoked, or a termination date is otherwise established by the Administrator of the Federal Aviation Administration.*

*Date of application:* May 11, 1999  
*Date of issuance:* June 30, 1999

*Date reissued:*  
*Date amended:* January 13, 2003

*By direction of the Administrator*  
  
(Signature)  
Acting Manager, Seattle Aircraft Certification Office  
(Title)



Any alteration of this certificate is punishable by a fine of not exceeding \$1,000, or imprisonment not exceeding 3 years, or both.

This certificate may be transferred in accordance with FAR 21.47.

FAA FORM 8110-2(10-88)

# Canadian STC

Canadian Approval was granted on September 17, 1999 by familiarization of FAA STC SR00711SE. Refer to the following letter.



Transport  
Canada  
  
Aviation

Transports  
Canada  
  
Aviation

Aircraft Certification Branch  
620 - 800 Burrard Street  
Vancouver, BC V6Z 2J8

Your file    Votre référence  
99-190S-423, -503  
Our file    Notre référence

September 17, 1999

Onboard Systems  
11212 NW Saint Helens Road  
Portland, OR 97231  
USA

Attention: Mr. Mark Lemmon

Subject: **Familiarization of STCs SR00711SE, SH829NW and SH695NW**

Dear Mr. Lemmon:

This is in response to your letters dated April 8, 1999 and July 12, 1999 making application for Canadian approval of the subject STCs. Hitherto Transport Canada policy has been a process of familiarizing FAA STCs and issuing corresponding Canadian documents. However following new policy now being implemented for certain categories of FAA STCs, some will be accepted entirely on the basis of the FAA document and entered on a national index.

This letter is your verification of the acceptance of the subject STCs by Transport Canada. Should you require additional information with regards to this matter or clarification please do not hesitate to contact Mr. Henry Wong at (604) 666-5597.

Yours truly,

H. W. Wong  
Regional Engineer, Aircraft Certification

for  
Minister of Transport

c.c. Mr. Ali Bahrami  
Manager, Seattle ACO

Canada

1/1



**European Aviation Safety Agency**

**SUPPLEMENTAL TYPE CERTIFICATE**

**EASA.IM.R.S.01287**

This certificate, established in accordance with Regulations (EC) No 1592/2002 and (EC) No 1702/2003 and issued to:

**Onboard Systems International**  
13915 NW 3rd Court  
98685 Vancouver  
Washington  
USA

certifies that the change in the type design for the product listed below with the limitations and conditions specified meets the applicable type certification basis and environmental protection requirements when operated within the conditions and limitations specified below:

**Original Product Type Certificate number:** *FAA TCDS 4H12*  
**Manufacturer:** *Schweizer*  
**Model:** *Schweizer 269 C*  
**Original STC Number:** *FAA STC SR00711SE*

**Description of Design Change:**

Validation of FAA STCSR00711SE , amended January 13, 2003, or later approved versions.



**European Aviation Safety Agency**

**Associated Technical Documentation:**

- Fabrication of Onboard Systems Model 200-244-00 cargo hook kit i.a.w. FAA approved onboard system MDL No 155-045-00, dated 3 May 1999, or later approved revision.
- Installation of this replacement cargo hook i.a.w. FAA approved Onboard System owner's manual No 120-081-00, dated 3 May 1999, or later approved revision.
- Inspection of this cargo hook i.a.w. Section 4 of Onboard System owner's manual No 120-081-00, dated 3 May 1999, or later approved revision.

**Limitations and Conditions:**

1. Approval of this STC apply only to those Schweizer 269C which were previously equipped with FAA approved installation of Schweizer cargo hook kit P/N 269A4971-27.
2. Modified rotorcraft must be operated i.a.w. FAA approved Rotorcraft Flight manual Supplement (RFMS) N0 120-081-00 dated June 30, 1999, or later approved revision
3. All other limitations in FAA STC STCSR00711SE
4. Prior to installation of this modification the installer must determine that the interrelationship between this modification and any other previously installed modification will introduce no adverse effect upon the airworthiness of the product. The installation of this modification by third persons is subject to written permission of the approval holder.

This certificate shall remain valid unless otherwise surrendered or revoked.

For the European Aviation Safety Agency,  
Date of Issue: 9 July 2007

  
/s/ Massimo MAZZOLETTI  
Certification Manager  
Rotorcraft, Balloons, Airships

**FAA APPROVED**

**ROTORCRAFT FLIGHT MANUAL SUPPLEMENT**

**Schweizer  
269C**

R/N \_\_\_\_\_ S/N \_\_\_\_\_

FAA Approval:

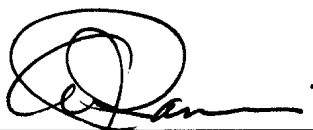

\_\_\_\_\_  
Manager, Special Certification Branch  
Seattle Aircraft Certification Office

Date: June 30, 1999

Revised: 12/31/02



Rotorcraft Flight  
Manual Supplement

Document Number

120-081-00

Cargo Hook

Page

1

# INTRODUCTION

This supplement must be attached to the appropriate approved Schweizer Rotorcraft Flight Manual when an Onboard Systems 200-244-00 Cargo Hook Kit is installed in accordance with Supplemental Type Certificate (STC) NO. SR00711SE. The information contained herein supplements or supersedes the basic manual only in those areas listed herein. For limitations, procedures and performance information not contained in this supplement, consult the basic Rotorcraft Flight Manual.

## I. LIMITATIONS

The basic Flight Manual remains applicable. When an Onboard Systems 200-244-00 Cargo Hook Kit is installed, the following placard applies:

- Mounted on bottom of Cargo Hook.

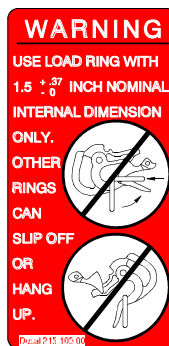

## II. PERFORMANCE

The basic Flight Manual remains applicable.

## III. PROCEDURES

Before each Cargo Hook use perform the following procedures. If the procedures are not successful do not use the equipment until the problem has been corrected.

1. Inspect all mounting fasteners to ensure that they are tight.
2. Visually inspect the electrical connector for loose or damaged pins and sockets.
3. Operate the keeper manually and check that it snaps back to its normal position on the load beam.
4. Inspect the case and covers for cracks and damage.
5. Inspect the load beam for gouges and cracks.
6. Cycle the manual release mechanisms to ensure proper operation.
7. Cycle the electrical release mechanisms to ensure proper operation.



Rotorcraft Flight  
Manual Supplement

Document Number

120-081-00

Cargo Hook

Page

2



### III. PROCEDURES, continued

#### Cargo Hook Rigging

Extreme care must be exercised in rigging a load to the Cargo Hook. If the load ring is too big it may work its way around the end of the load beam and be supported for a time on the keeper and then fall free. If the load ring is too small it may jam itself against the load beam during an attempted release. The following illustrations show recommended configurations and potential difficulties that must be avoided.

**WARNING:** The examples shown are not intended to represent all problem possibilities. It is the responsibility of the operator to assure the hook will function properly with the rigging.

Figure 1 Examples of correct and incorrect cargo hook rigging

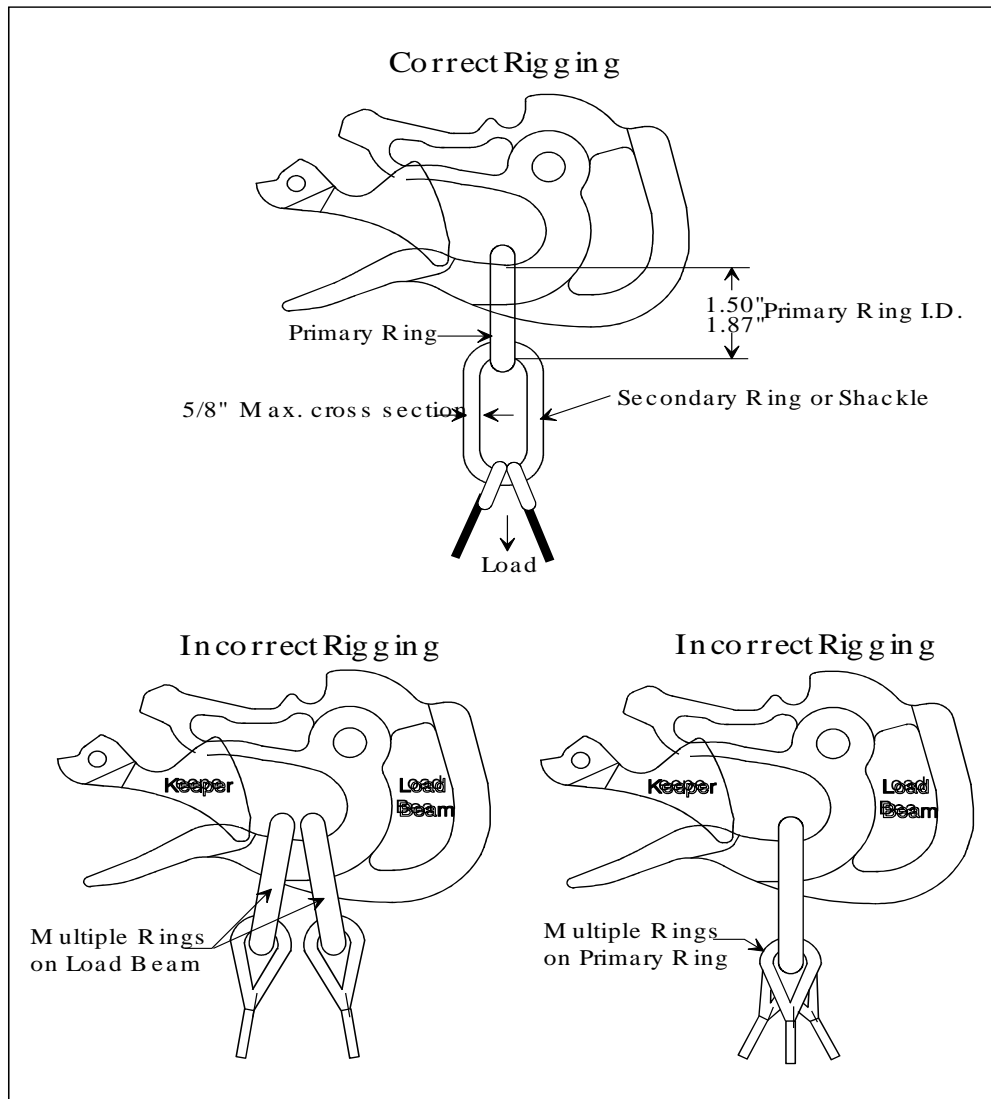

### III. PROCEDURES, continued

#### Un-Commanded Release Due to Too Large of a Load Ring

**WARNING:** Load rings that are too large will cause an un-commanded release. The ring will flip over the end of the load beam and flip the keeper up and then fall free. Only correctly sized load rings must be used. See examples below.

Figure 2 Un-commanded release due to load rings that are too large

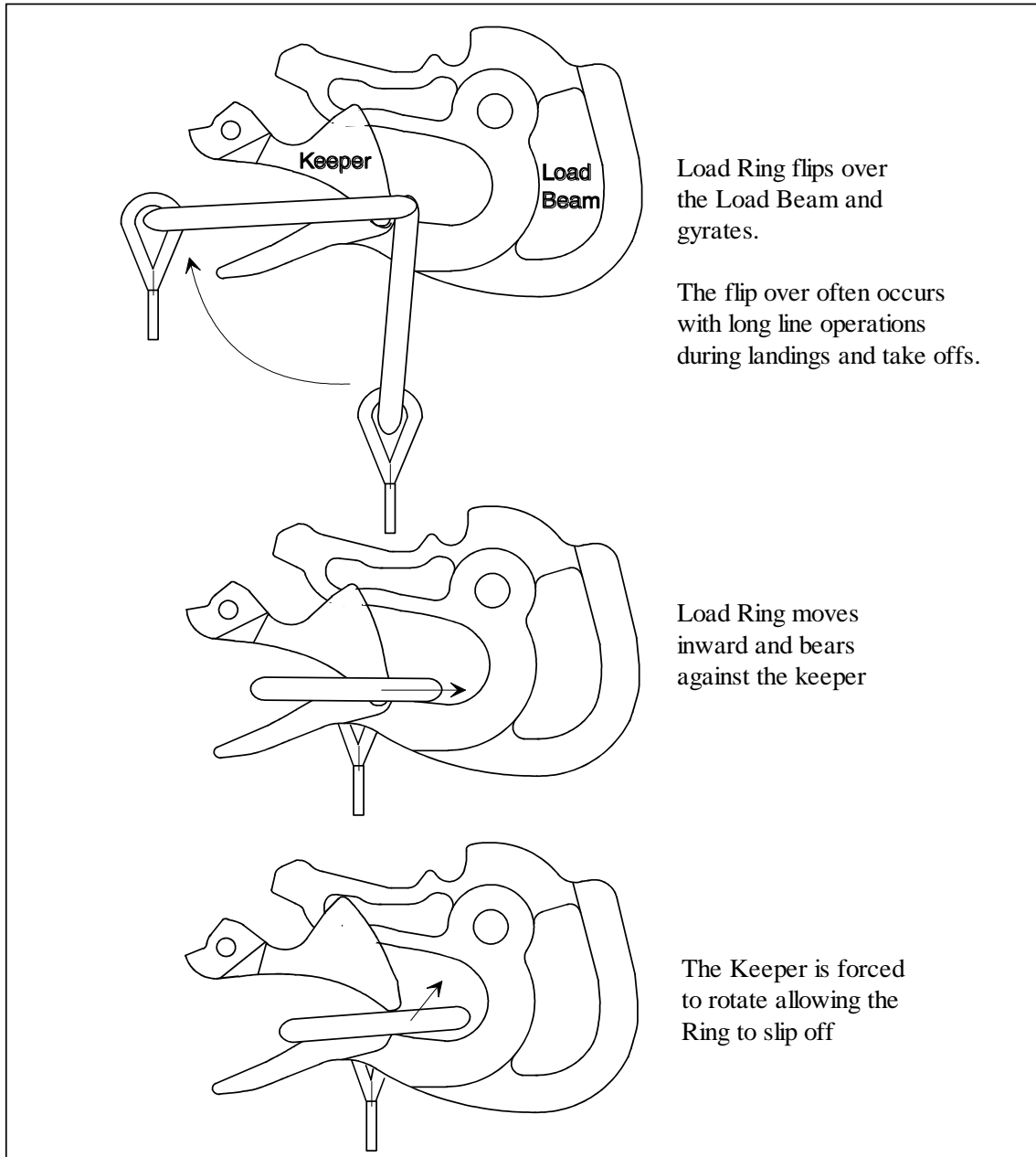

### III. PROCEDURES, continued

#### Load Hang-Up Due to Too Small of a Load Ring or Multiple Load Rings

**WARNING:** Load rings that are too small or multiple load rings will hang on the load beam when the load is released. Only correctly sized load rings must be used. See examples below.

Figure 3 Load hang-up due to load rings that are too small or using multiple load rings

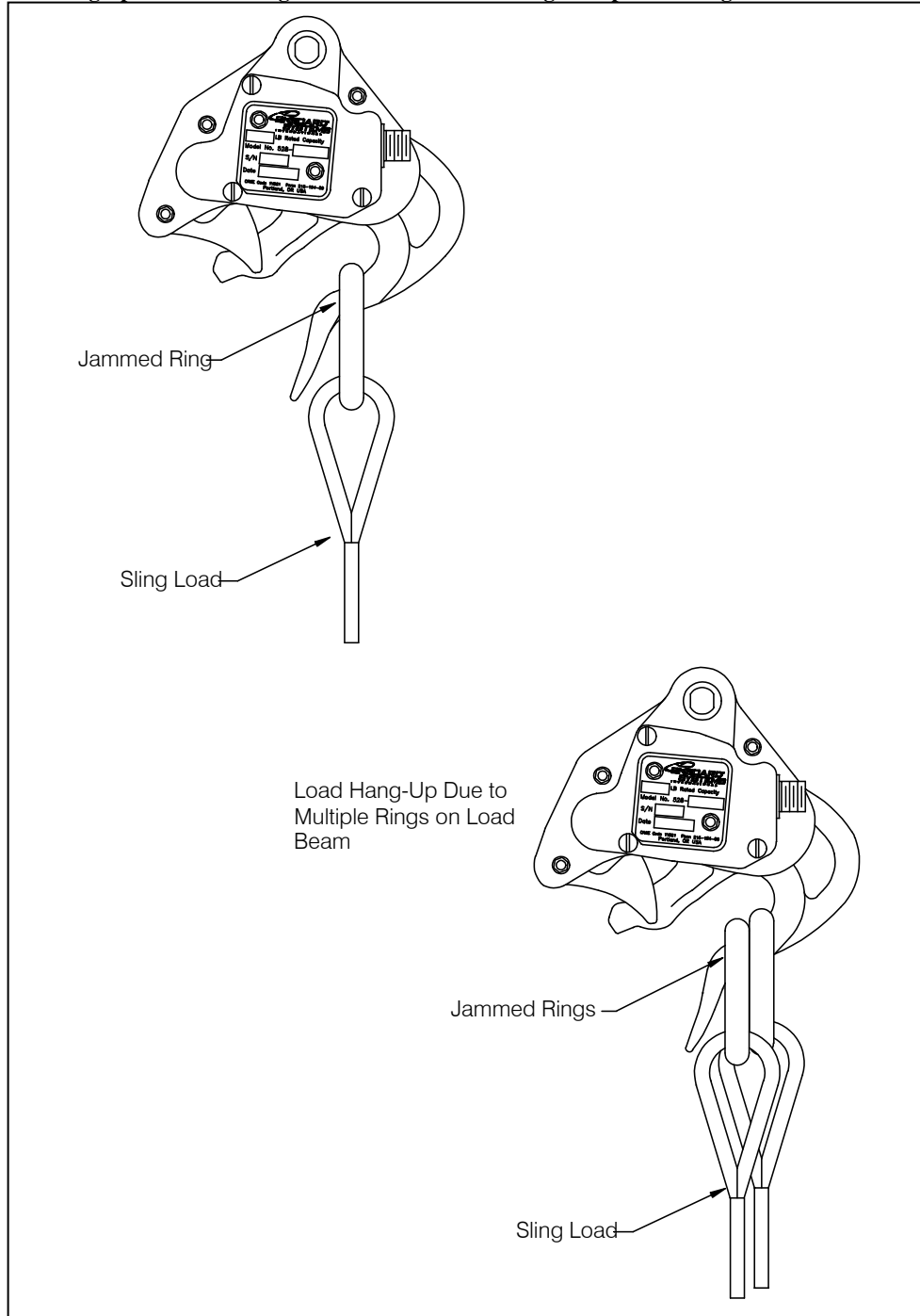

### III. PROCEDURES, continued

#### Un-Commanded Release Due to Nylon Type Straps

**WARNING:** Nylon type straps (or similar material) must not be used directly on the cargo hook load beam as they have a tendency to creep under the keeper and fall free. If nylon straps must be used they should first be attached to a correctly sized primary ring. Only the primary ring should be in contact with the cargo hook load beam. See examples below.

Figure 4 Un-commanded release due to nylon type straps

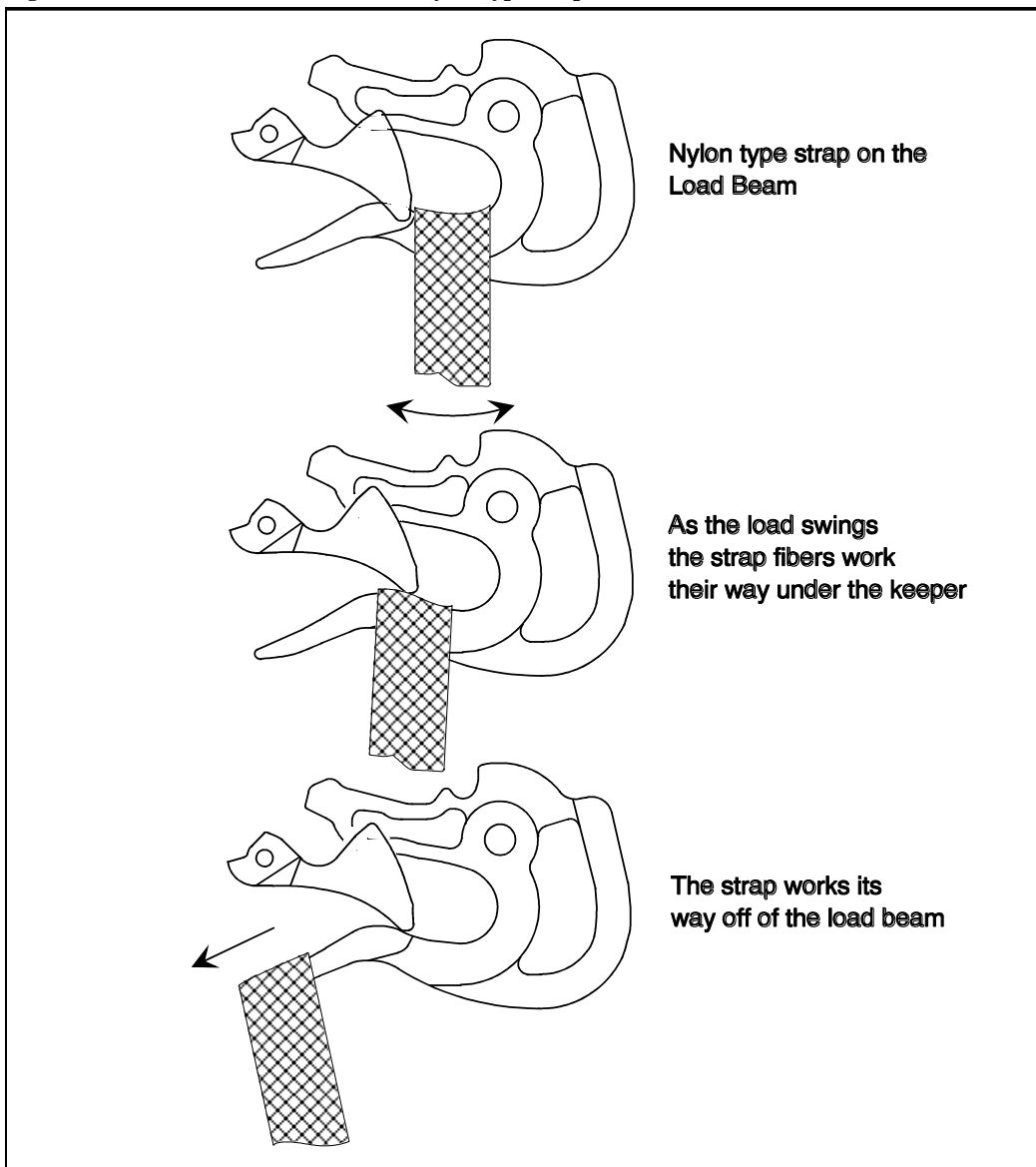

### III. PROCEDURES, continued

#### Un-Commanded Release Due to Cable or Rope Type Straps

**WARNING:** Cable or rope type straps must not be used directly on the cargo hook load beam. Their braided eyes will work around the end of the load beam and fall free. If cable or rope is used they should first be attached to a correctly sized primary ring. Only the primary ring should be in contact with the cargo hook load beam. See examples below.

Figure 5 Un-commanded release due to cable or rope type straps

