

**PLEASE CHECK WEB SITE AT WWW.ONBOARDSYSTEMS.COM FOR  
THE LATEST REVISION OF THIS MANUAL**

**Cargo Hook  
Suspension System  
For the  
Bell 206L & 407 Series With  
Big Mouth Cargo Hook**

**System Part Numbers  
200-249-00, W/O Load Weigh  
200-250-00, W/ Load Weigh**

*Owner's Manual Number 120-085-00  
Revision 10  
03/17/15*



*13915 N. W. 3<sup>rd</sup> Court Vancouver Washington 98685 USA  
Phone: 360-546-3072 Fax: 360-546-3073 Toll Free: 800-275-0883  
www.OnboardSystems.com*

This page intentionally left blank.

## RECORD OF REVISIONS

<i>Revision</i>	<i>Date</i>	<i>Page(s)</i>	<i>Reason for Revision</i>
6	01/18/07	2-5, 2-6, 2-9, & 2-14 Section 5  Section 1, 2-6, 2-9, Section 3 & Section 4	Updated figures to show new knob P/N 290-471-02.  Updated Overhaul schedule to be concurrent with cargo hook overhaul.  Updated Warning Cautions and notes to current format.
7	04/16/07	1-2, 2-1, 5-5, 5-8	Updated p/n's and figures to show new pillow block configuration 232-030-02.  Updated penetrant inspection specification and revised max. permissible bushing clearances.  Removed RFMS from Owners manual created new RFMS, 121-045-00.
8	08/11/09	1-2 & 5-8	Changed manual release cable from P/N 268-004-00 to 268-004-01. 268-004-01 provides improved service life.
9	3/2/10	Section 2 & Section 5	Updated manual to reflect new load weigh harness configuration. Updated EMI note in Installation Check-out section. Re-arranged Maintenance section and added an annual/100 hour inspection.
10	03/17/15	All	Added Load Cell P/N 210-179-01, updated format of safety labels, clarified definition of external load operations, general re-formatting and minor editing throughout.

### **Register Your Products for Automatic Notifications**

Onboard Systems offers a free notification service via fax or email for product alerts and documentation updates. By registering your Onboard Systems products at our website, we will be able to contact you if a service bulletin is issued, or if the documentation is updated.

You can choose to receive notices on an immediate, weekly, or monthly schedule via fax, email or both methods. There is no charge for this service. Please visit our website at [www.onboardsystems.com/notify.php](http://www.onboardsystems.com/notify.php) to get started.

*This page intentionally left blank.*

# ***CONTENTS***

## ***Section 1*** **General Information**

Introduction, 1-1  
Safety Labels, 1-1  
Bill of Materials, 1-2  
Inspection, 1-3  
System Specifications, 1-3  
Indicator Specifications, 1-3  
Indicator Pin out, 1-4  
Load Cell Specifications, 1-4

## ***Section 2*** **Installation Instructions**

Cargo Hook Suspension System Removal, 2-1  
Cargo Hook Suspension System Installation, 2-1  
Load Weigh System Internal Harness Installation, 2-10  
C-39 Cockpit Indicator Installation, 2-10  
Indicator Internal Back Light, 2-10  
Indicator Hook-Open Warning, 2-11  
Remote Analog Meter, 2-11  
Electrical Connections, 2-11  
Installation Check-Out, 2-13  
Component Weights, 2-13  
Paper Work, 2-13

## ***Section 3*** **Cargo Hook Suspension System Operation Instructions**

Operating Procedures, 3-1  
Cargo Hook Rigging, 3-2

## ***Section 4*** **Load Weigh System Operation Instructions**

Indicator Front Panel, 4-1  
The Run Mode, 4-2  
    To Zero or Tare the Display, 4-3  
    To Un-Zero the Display, 4-3  
    Error Codes, 4-4  
The Setup Mode, 4-5  
    Indicator Dampening, 4-7  
        To look at, or change the dampening level, 4-7  
    Indicator Calibration, 4-7  
        To look at or change the calibration code, 4-8  
    Installation Zero, 4-9  
        To run the installation zero routine, 4-9

# ***CONTENTS***, continued

## ***Section 4*** **Load Weigh System Operation Instructions**, continued

Calibration by Lifting a Known Weight, 4-9

To run calibration by known weight routine, 4-10

Setting the Scale on a Remote Analog Meter, 4-11

To look at or change the scale, 4-11

Select KG or LB Units, 4-12

To look at or change the units, 4-12

Indicator Version, 4-13

## ***Section 5*** **Maintenance**

Storage Instructions, 5-1

Preventive Maintenance, 5-1

Inspection, 5-1

Overhaul, 5-3

Cargo Hook Suspension System Overhaul Inspection, 5-3

Beam Assembly Procedures, 5-5

Cargo Hook Suspension System Parts, 5-6

Trouble Shooting, 5-8

Instructions for Returning a System to the Factory, 5-10

## ***Section 6*** **Certification**

FAA STC, 6-1

Canadian STC, 6-2

# Section 1

## General Information

### Introduction

The P/N 200-249-00 & P/N 200-250-00 Cargo Hook Suspension System is approved for installation on the 206L and 407 series helicopters. The system replaces the Bell 206-706-341-101, -105, and -109 Auxiliary Equipment Kit- Cargo Hook. It must be installed with the Bell part number 206-706-341-7,-9,-103,-111 or -113 Auxiliary Equipment Kit- Cargo Hook Provisions.

### Safety Labels

The following definitions apply to safety labels used in this manual.



Indicates a hazardous situation which, if not avoided, will result in death or serious injury.



Indicates a hazardous situation which, if not avoided, could result in death or serious injury.



Indicates a hazardous situation which, if not avoided, could result in minor or moderate injury.



Draws the reader's attention to important or unusual information not directly related to safety.



Used to address practices not related to personal injury.

## Bill of Materials

The following items are included with the Cargo Hook Kit, if shortages are found contact the company from whom the system was purchased. The Bell Helicopter provisions kit is required to complete the installation.

Part No.	Description	200-249-00 Quantity	200-250-00 Quantity	200-245-00 Quantity*
120-085-00	Owner's Manual	1	1	-
122-002-00	Cargo Hook Service Manual	1	1	-
210-095-00	C-39 Indicator	-	1	1
210-167-00	Beam Assembly w/o Load Cell	1	-	-
210-178-00	Beam Assembly with Load Cell	-	1	-
210-179-01**	E-85 Load Cell	-	-	1
215-010-00	Placard	-	2	2
215-012-00	Placard	-	1	1
232-030-02	Pillow Block Assembly	2	2	-
235-035-00	QD Bracket	-	1	1
268-004-01	Manual Release Cable	1	1	-
270-048-04	Harness Assembly	-	1	1
270-095-00	Electrical Release Cable	1	1	-
290-331-00	Release Fitting	1	1	-
290-370-00	Trunnion Pin	2	2	-
290-374-00	Thrust Spacer	10	10	-
400-048-00	Power Switch	-	1	1
510-028-00	Screw	-	6	6
510-029-00	Nut	-	6	6
510-062-00	Washer	-	8	8
510-095-00	Washer	2	2	-
510-100-00	Washer	2	2	-
510-102-00	3/16 Nut	2	2	-
510-114-00	Nut	2	2	-
510-229-00	Bolt	2	2	-
510-230-00	Bolt	2	2	-
510-234-00	Nut	4	4	-
510-235-00	Bolt	4	4	-
512-001-00	Ty-Wrap	-	10	10
528-017-00	3,500 Lb. Cargo Hook	1	1	-
600-006-00	Release Cable Disconnect	1	1	-
512-010-00	Adel Clamp	1	1	-

\* The 200-245-00 P/N is a modification kit that can be purchased separately to convert the 200-249-00 to 200-250-00.

\*\* P/N 210-179-01 supersedes P/N 210-179-00. These P/Ns are interchangeable.



## Inspection

Inspect the kit items for evidence of damage, corrosion and security of lock wire and fasteners. If damage is evident, do not use the items until they are repaired.

## System Specifications

**Table 1-1 System Specifications**

Design load	3,000 lb. (1360 kg.)
Design ultimate strength	13,500 lb. (6120 kg.)
Unit weight P/N 200-249-00	14.75 pounds (6.69 kg.)
Unit weight P/N 200-250-00	15.25 pounds (5.691 kg.)

**Table 1-2 P/N 528-017-00 Cargo Hook Specifications**

Design load	3,500 lb. (1,580 kg.)
Design ultimate strength	15,750 lb. (7,140 kg.)
Electrical release capacity	8,750 lb. (3,970 kg.)
Mechanical release capacity	8,750 lb. (3,970 kg.)
Force required for mechanical release at 3,500 lb.	10 lb. Max. (.600" travel)
Electrical requirements	22-28 VDC 9 amps
Minimum release load	10 pounds
Unit weight	5.75 pounds (2.6 kg.)
Mating electrical connector	PC06A8-2S SR

## Indicator Specifications

**Table 1-3 Indicator Specifications**

<b>Specifications</b>	<b>210-095-00</b>
Size	Fits standard 2¼" clock hole
Weight	.43 lbs (.20 kgs)
Operating Voltage	16 to 31 VDC
Current Consumption	< 25 mA
Accuracy Over Operating Temperature Range	0.1% ± 1 digit
Operating Temperature Range	+70°C to -45°C
Storage Temperature Range	+80°C to -50°C
Scaleable Analog Output	0 to 5VDC ± 0.5%

## Indicator Pin Out

The connector located on the back of the Indicator has the following pin out.

**Table 1-4 Indicator Pin Out**

<i>Pin Letter</i>	<i>Function</i>
A	+ 28 VDC In
B	- Load Cell Signal
C	+ Load Cell Signal
D	+ Load Cell Excitation
E	Load Cell Common
F	Analog Out Common
G	+ Analog Out
H	Hook Open
J	Data Recorder Clock
K	Data Recorder Data
L	Shield
M	Back Light Common
N	Back Light Source
P	Aircraft Ground
R	Not Used

## Load Cell Specifications

**Table 1-5 Load Cell Specifications**

<b>SPECIFICATIONS</b>	<b>LOAD CELL</b>
Weight	.50 lbs (.23 kgs)
Accuracy Over Operating Temperature Range	0.5% ± 1 digit
Operating Temperature Range	+70°C to -45°C
Storage Temperature Range	+80°C to -50°C

## Section 2

# Installation Instructions

These procedures are provided for the benefit of experienced aircraft maintenance facilities capable of carrying out the procedures. They must not be attempted by those lacking the necessary expertise.

### Cargo Hook Suspension System Removal

If the aircraft is equipped with a Bell Helicopter 206-706-341-(101, 105, or 109) Auxiliary equipment kit cargo hook, remove it before proceeding with the installation.

### Cargo Hook Suspension System Installation

Install the Bell Helicopter 206-706-341-7,-9,-103,-111,-113 provisions kit as outlined in the kit instructions.

Attach the two 232-030-02 Pillow Block Assemblies as illustrated below. Note that they install exactly as the Bell pillow blocks with the exception of the P/N 510-235-00 bolts. They are a shorter grip length than is used with the Bell pillow blocks and they are installed with the heads down to give clearance for the beam when it rotates. Use sealant on the faying surfaces.

**Figure 2-1 Pillow Block Installation**

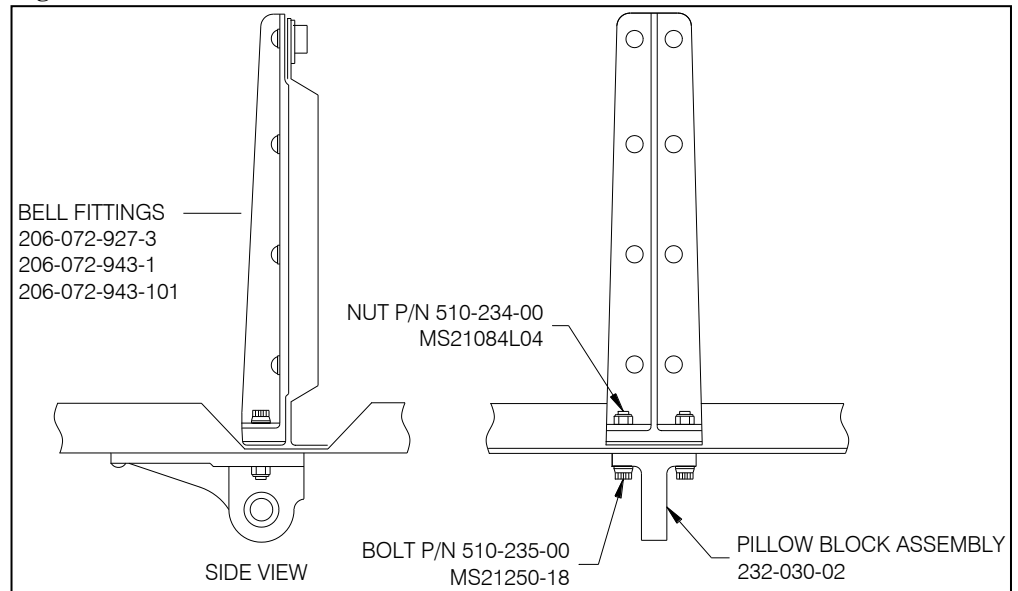

## Cargo Hook Suspension System Installation, continued

Attach the Beam Assembly, P/N 210-167-00 or 210-178-00, to the Pillow Blocks as illustrated. Note, the long end of the Carriage must point to the left side of the aircraft. As illustrated below.

Position the Thrust Spacers, P/N 290-374-00, on both sides of the Pillow Blocks to center the Beam Assembly between the Pillow Blocks and allow .000/.060 lateral movement of the beam assembly. The thrust spacers must be positioned on both sides of the pillow block so that when a lateral load is applied, the beam will not rub directly (metal to metal) against the pillow block. In addition to the above, the thrust spacers must be positioned so that when a lateral load is applied it will be distributed to both pillow blocks. To check this, apply an approx. 10 pound load to the beam in the lateral direction. There should be a maximum of .060 gap when measured as shown in the Figures 2-3 and 2-4.

**Figure 2-2 Cargo Hook Suspension Assembly Installation**

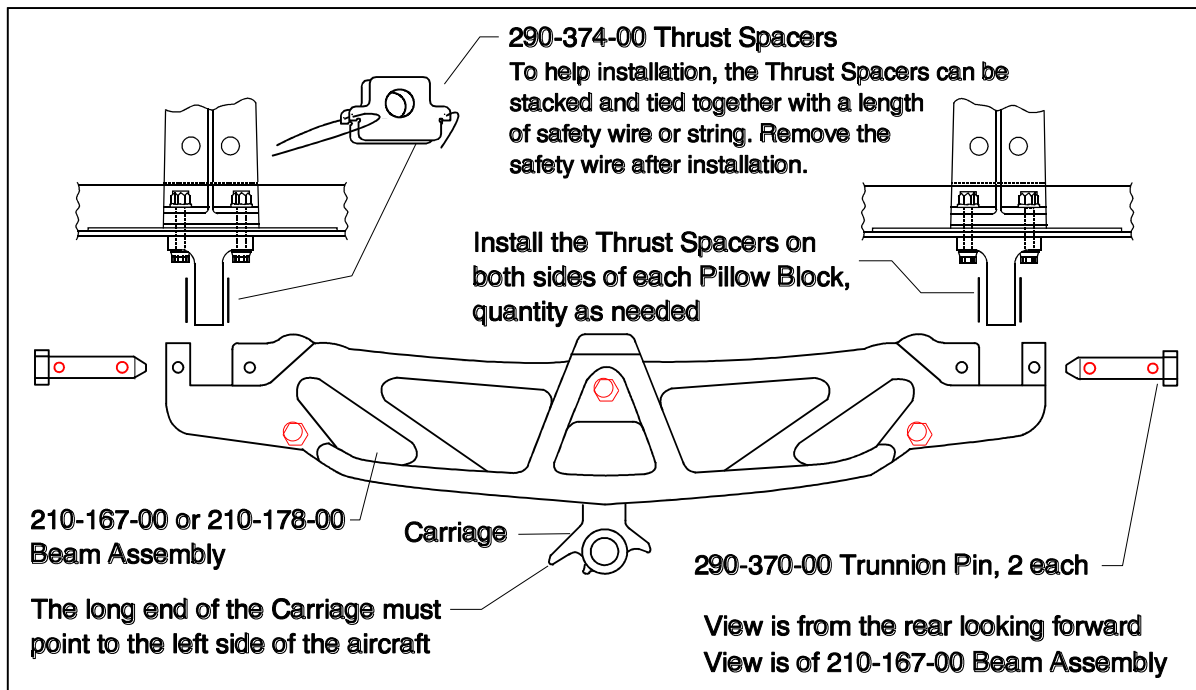

# Cargo Hook Suspension System Installation, continued

Figure 2-3 Beam Assembly, Left End Play Adjustment

Move the Beam Assembly in this direction with approximately 10 pounds force and then measure the gap between the Thrust Spacers and the Beam Assembly at the locations illustrated. Add sufficient Thrust Spacers to make the gap .00 to .060 inches at both locations.

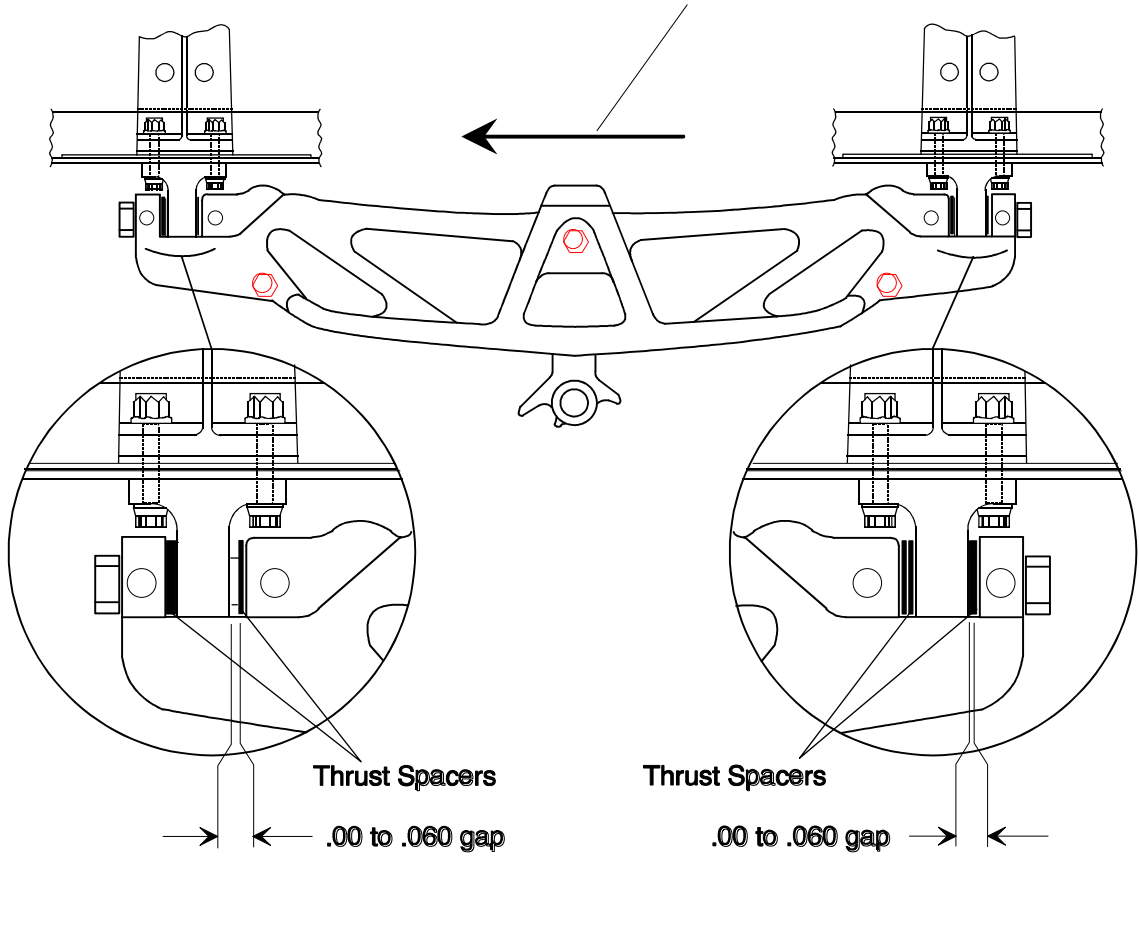

# Cargo Hook Suspension System Installation, continued

Figure 2-4 Beam Assembly, Right End Play Adjustment

Move the Beam Assembly in this direction with approximately 10 pounds force and then measure the gap between the Thrust Spacers and the Beam Assembly at the locations illustrated. Add sufficient Thrust Spacers to make the gap .00 to .060 inches at both locations.

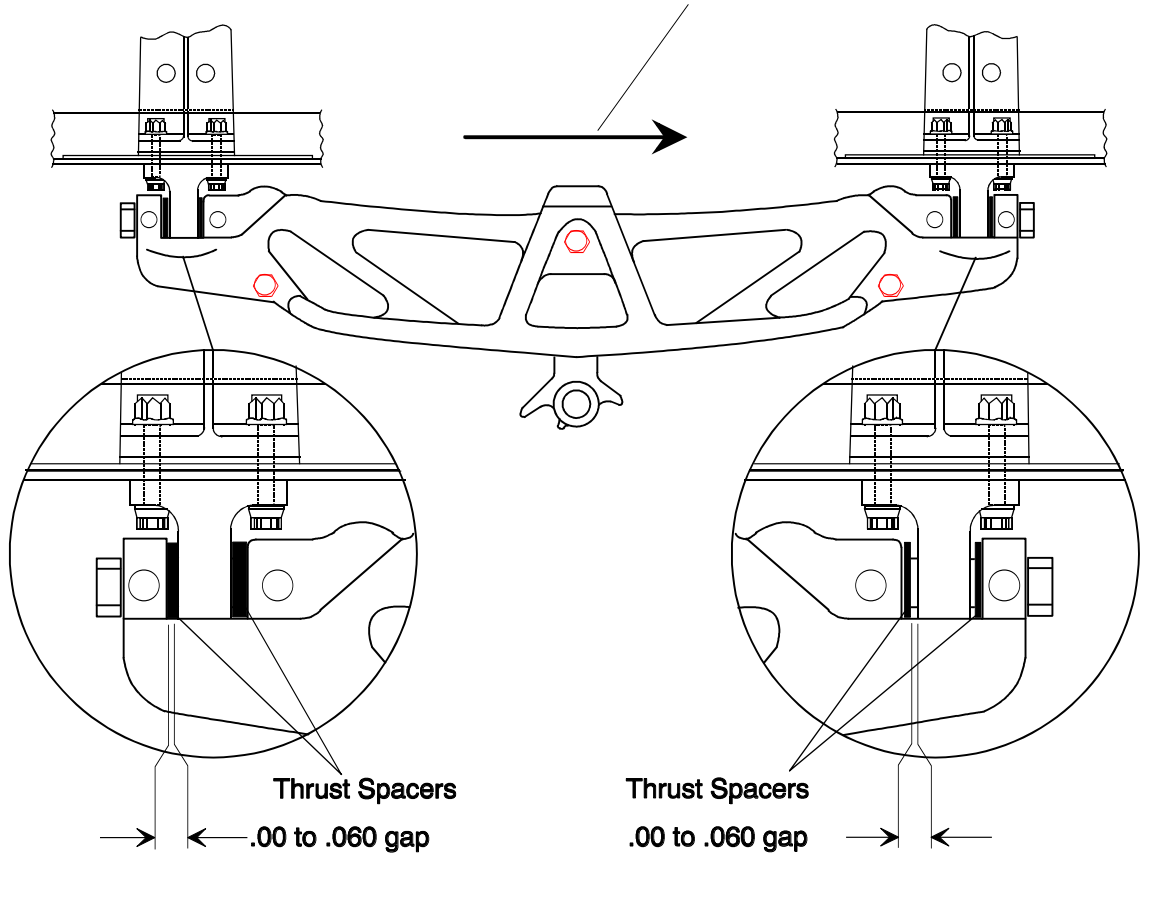

## Cargo Hook Suspension System Installation, continued

Secure the two Trunnion Pins, P/N 290-370-00, with the fasteners as illustrated.

**Figure 2-5 Trunnion Pin Fasteners**

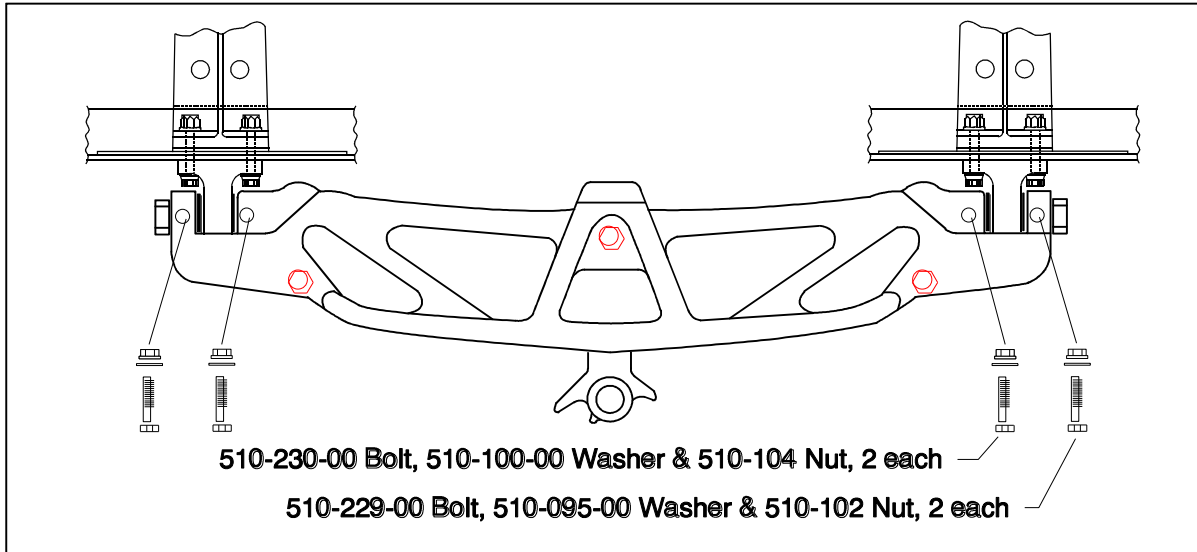

Attach the Cargo Hook, P/N 528-017-00 to the Suspension Assembly as illustrated. The Cargo Hook Load Beam must point to the right.

**Figure 2-6 Cargo Hook to Carriage Installation**

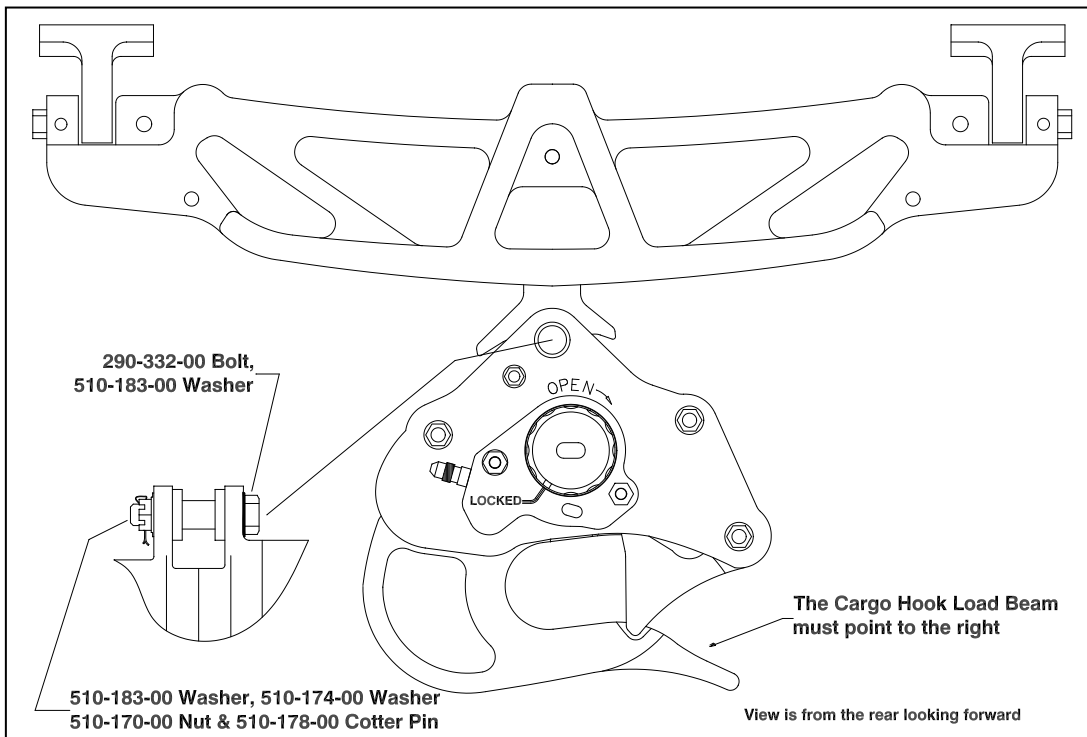

## Cargo Hook Suspension System Installation, continued

Remove the manual release cover from the new cargo hook. Thread the manual release adapter, P/N 290-331-00 into the new cargo hook manual release cover. Connect the manual release cable to the adapter. Place the cable ball end fitting into the hook manual release fork fitting as illustrated in Figure 2-7. Install the manual release cover and through the inspection window measure the free play with the manual release knob in the non-release position. Check that there is a minimum of .125" of freeplay at the fork fitting as shown in Figure 2-7.

**Figure 2-7 Manual Release Cable Rig**

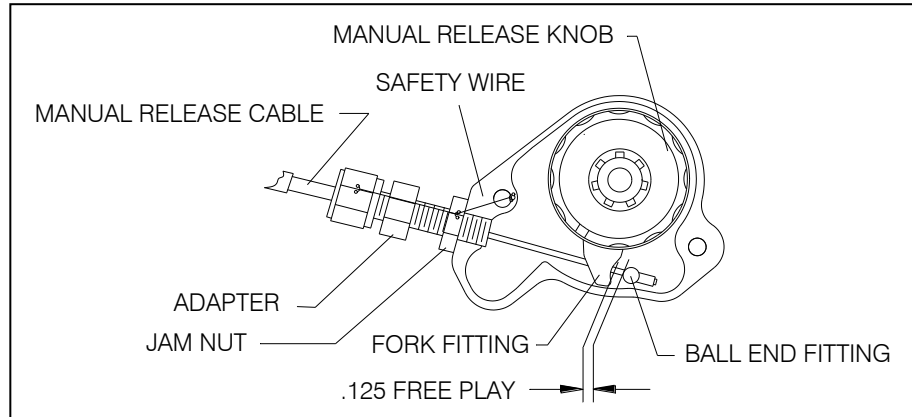

Connect the cargo hook electrical release cable connector to the Cargo Hook. Clock the 90 degree strain relief so that the wire bundle does not contact the manual release cable assembly when the hook is moved to that side of the trolley. Listed below is the pin out for the cargo hook connector.

**Table 2-1 Cargo Hook Connector**

Pin	Function
A	Ground
B	Positive

# CAUTION

*The Cargo Hook is equipped with a suppression diode that will be damaged if the Cargo Hook electrical connections are reversed. Do not attach the electrical connector until the polarity of the aircraft connector is determined to be compatible with the Cargo Hook connector listed in Table 2-1.*

Route the Manual and the Electrical Release cables as illustrated in Figures 2-8 and 2-9.



# Cargo Hook Suspension System Installation, continued

Figure 2-8 Manual and Electrical Release Cable Routing, without Load Weigh

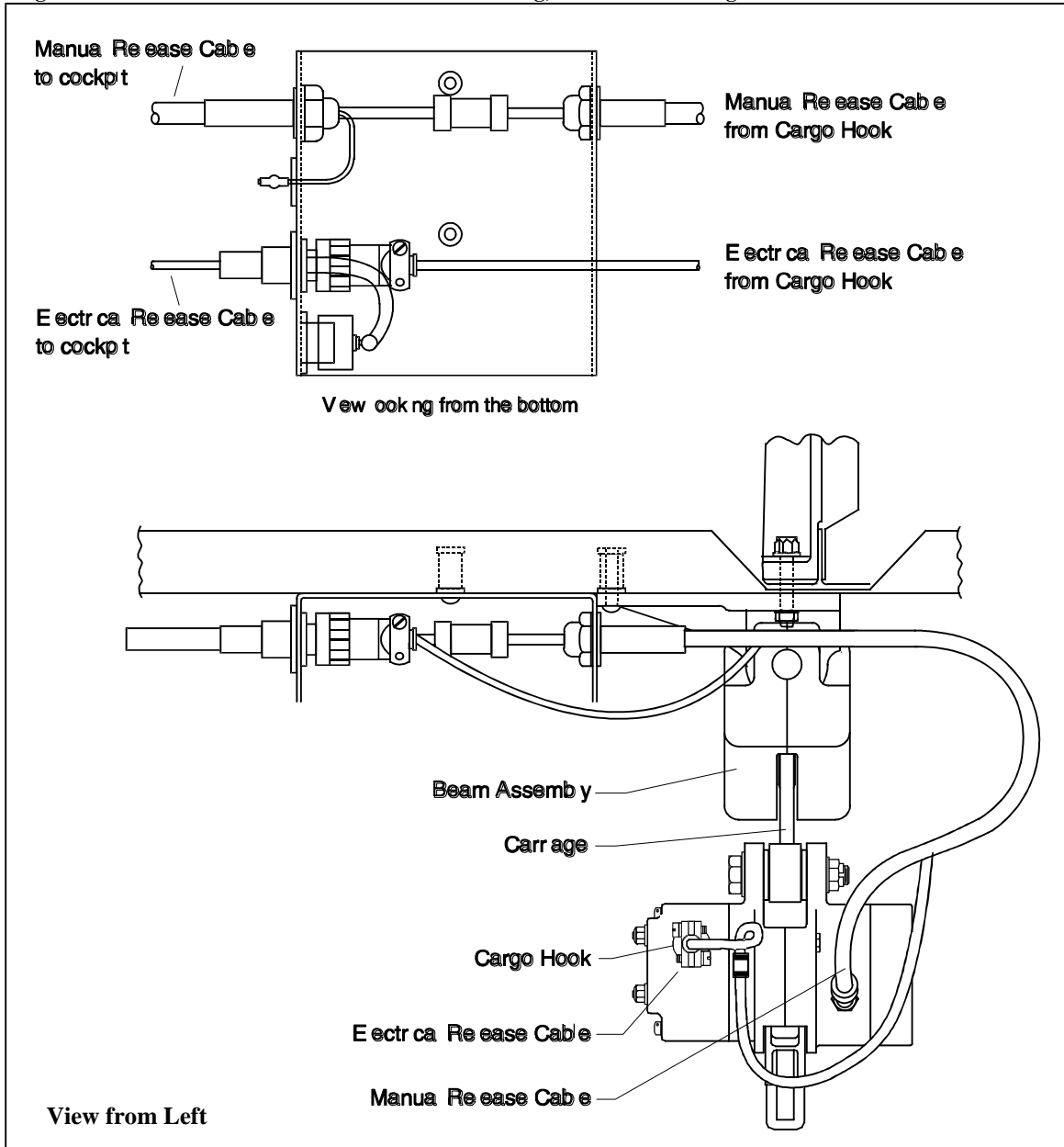

# Cargo Hook Suspension System Installation, continued

Figure 2-9 Manual and Electrical Release Cable Routing, with Load Weigh

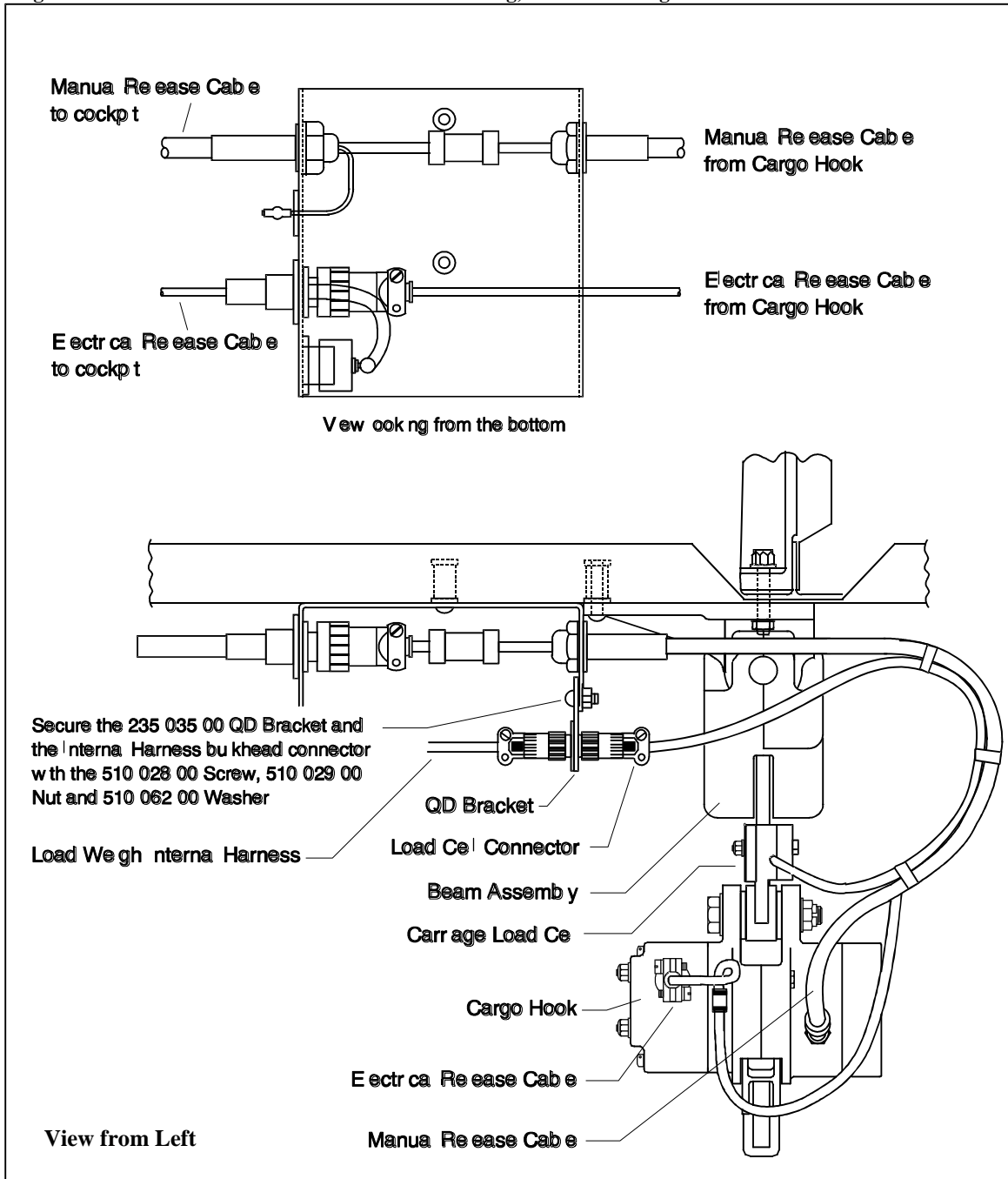

## Cargo Hook Suspension System Installation, continued

### **WARNING**

*Un-commanded cargo hook release will happen if the manual release cable is improperly restrained. The cable must not be the stops that prevent the Cargo Hook from swinging freely in all directions. If the Cargo Hook loads cause the hook to strain against the manual release cable the swaged end of the cable may separate allowing the inner cable to activate the cargo hook manual release mechanism. The result is an un-commanded release. Ensure that no combination of cyclic stick or Cargo Hook position is restrained by the manual release cable.*

**Figure 2-10 Un-commanded Release From Incorrectly Secured Cable**

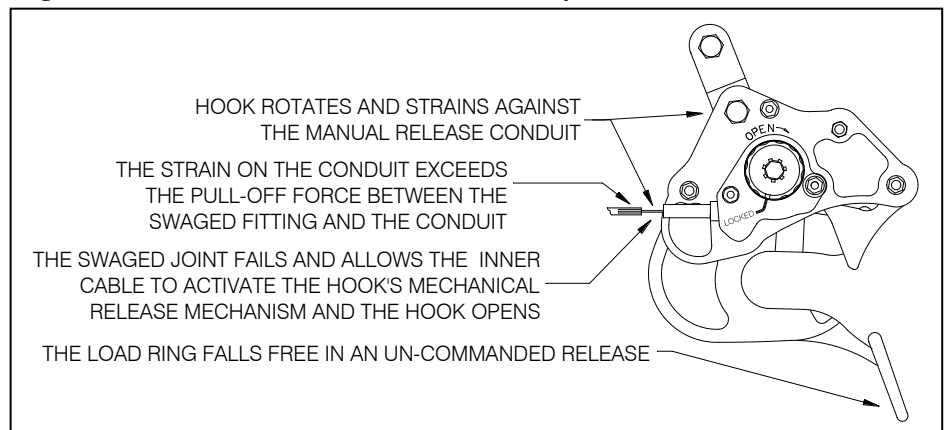

## Load Weigh System Internal Harness Installation

The Internal Harness is made up of four cables terminated to one large connector. The connector is plugged into the back of the Indicator. One of the cables is marked "LOAD CELL" and is fitted with a bulkhead fitting. Hardware is provided to attach the bulkhead fitting to the Quick Disconnect Bracket, P/N 235-035-00. Attach the Quick Disconnect Bracket to the bracket that holds the manual and electrical release fittings on the skin of the aircraft at the cargo hook area.

Another cable is marked "POWER" and is connected to the aircraft electrical power. Another cable is marked "LIGHT", refer to the *Indicator Internal Back Light* section for installation instructions. The last cable is marked "DATA" and can be connected to the optional Data Recorder or Analog Slave Meter. These items are not included under this STC. Stow the Data cable if it is not to be used.



*The data cable may or may not be terminated with a connector depending on manufacture date.*

Route the cables in the most convenient manner. Secure the cables to the existing wiring bundles with the Ty-wraps. Secure the cables clear of flight control rods.

## C-39 Cockpit Indicator Installation

The Indicator, P/N 210-095-00, should be mounted in a position that is convenient, accessible and visible to the pilot. It can be mounted in a standard 2¼" instrument hole. Connect the Indicator to its Internal Harness, refer to *Internal Harness Installation*.

## Indicator Internal Back Light

The Indicator is equipped with an Internal Back Lighting System that can be connected to the aircraft 28 VDC light dimming circuit. Use a 22 gauge, twisted pair, shielded cable to connect the aircraft dimming circuit to the Internal Harness. Connect the cable shield wire to airframe ground at the light dimmer end of the cable ONLY.

## Indicator Hook-Open Warning

The Indicator is equipped with a Hook-Open Warning feature that can be connected to a cargo hook equipped with a hook open switch. Depending on the capabilities of the cargo hook switch, the Indicator will flash "HOOK OPEN" when the cargo hook load beam is open. The cargo hook switch must be normally open when the cargo hook load beam is in the closed position. When the load beam is open, one side of the switch must be grounded and the other side of the switch is to be connected to the Indicator. Use a 22 gauge, shielded wire to connect the cargo hook switch to the Indicator. Disassemble the Indicator mating connector and carefully solder the wire, from the cargo hook switch, to pin H. Connect the cable shield wire to airframe ground as close to the cargo hook as possible, at the cargo hook end of the cable **ONLY**.

## Remote Analog Meter

The Indicator is equipped with an Analog drive circuit that can be connected to a remote analog meter. Use a 22 gauge, twisted pair, shielded cable to connect the Remote Analog Meter to the Indicator. Disassemble the Indicator mating connector and carefully solder the positive wire, from the analog meter, to pin G and the common wire to pin F. Connect the cable shield wire to airframe ground as close to the Analog Meter as possible, at the Analog Meter end of the cable **ONLY**.

The 210-095-00 Indicator can be connected to Onboard Systems' Analog Slave Meter, P/N 210-180-00, through the "DATA" cable. This meter gives solid weight indications without needle bounce. The Analog Slave Meter may be mounted in any convenient location in a standard 3" instrument hole. Attach connector, P/N 410-130-00, to data line per pin out in Figure 2-11 to connect the Analog Slave Meter to the Internal Harness "DATA" cable. If a data connector is present on the data line use cable P/N 270-059-00 to connect to Analog Slave Meter.

## Electrical Connections

Install the supplied power switch, part number 400-048-00. The "POWER" cable on the Internal Harness is supplied extra long, cut off the excess cable and use as needed to connect the switch and circuit breaker. Connect the "POWER" white (red if wire harness 270-048-00 is installed) wire to one side of the power switch, connect another piece of suitable wire to the other side of the switch and then to an available 1 or 2 amp circuit breaker as illustrated in Figure 2-11. Connect the circuit breaker to the 24 VDC bus. Connect the white/blue (black if wire harness 270-048-00 is installed) wire to the ground bus. The bare wire (present on P/N 270-048-00 harness only) should be cut off as it is not needed at this end of the cable. Use a minimum of 22 gauge wire to make all connections. Secure the connections and protect from corrosion.

**Figure 2-11 Wiring Arrangement**

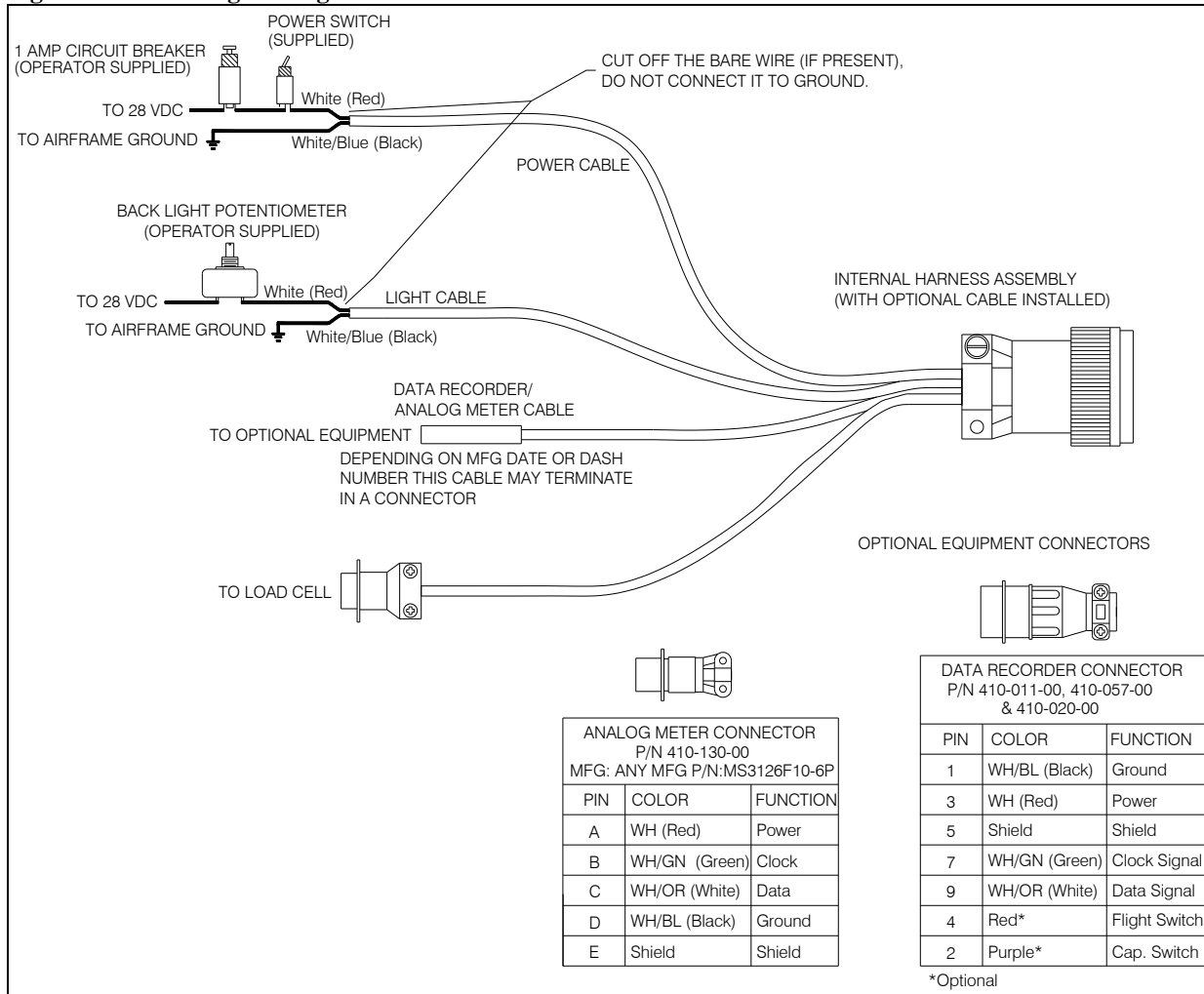

Connect the Internal Harness to the Indicator connector. Install the placard 215-010-00 “ELECTRONIC WEIGHING SYSTEM” next to the power switch and circuit breaker. Install the placard 215-012-00 “TURN THE WEIGHING SYSTEM OFF WHEN NAVIGATION EQUIPMENT IN USE” “NO AIRCRAFT OPERATION SHOULD BE PREDICATED ON THE READING OF THE ONBOARD WEIGHING SYSTEM” next to the Indicator.

# NOTICE

*If the C-23 Printer is being utilized with the C-20 or C-30 Data Recorder, a 5 amp circuit breaker should be used.*

## Installation Check-Out

After installation of the Cargo Hook Suspension System, perform the following functional checks.

1. Swing the installed Cargo Hook to ensure that the manual release cable assembly and the electrical release cable have enough slack to allow full swing of the suspension assembly without straining or damaging the cables. The cables must not be the stops that prevent the Cargo Hook from swinging freely in all directions.
2. Apply 10-20 pounds to the cargo hook load beam and pull the handle operated cargo hook mechanical release, the Cargo Hook should release.
3. Close the cargo hook release circuit breaker and position the battery switch to the ON position. Apply 10-20 pounds to the cargo hook load beam and depress the cargo hook electrical release button, the Cargo Hook should release.
4. See the Bell Helicopter service instructions for your specific helicopter model for additional installation instructions.
5. Perform an EMI ground test per AC 43.13-lb section 11-107. For equipment that can only be checked in flight an EMI flight test may be required.

### NOTICE

*The cargo hook and load cell are of a class of equipment not known to have a high potential for interference. This class of equipment does not require special EMI installation testing (i.e. FADEC) as required in paragraphs 7 and 8 of FAA policy memorandum ASW-2001-01.*

## Component Weights

The weight of the Cargo Hook Suspension System components are listed below.

**Table 2-2 Component Weights**

Item	Weight
Suspension System W/ hook, W/O Load Cell	14.75 lbs (6.9 kgs)
Suspension System W/ hook, W/ Load Cell	15.25 lbs (6.9 kgs)
Indicator	.43 lbs (.20 kgs)

## Paper Work

Remove the Flight Manual Supplement from the back of this manual and place it into the Rotorcraft Flight Manual. In the US fill in FAA form 337 for the initial installation. This procedure may vary in different countries. Make the appropriate aircraft log book entry.

**Figure 2-12 System Installation Overview**

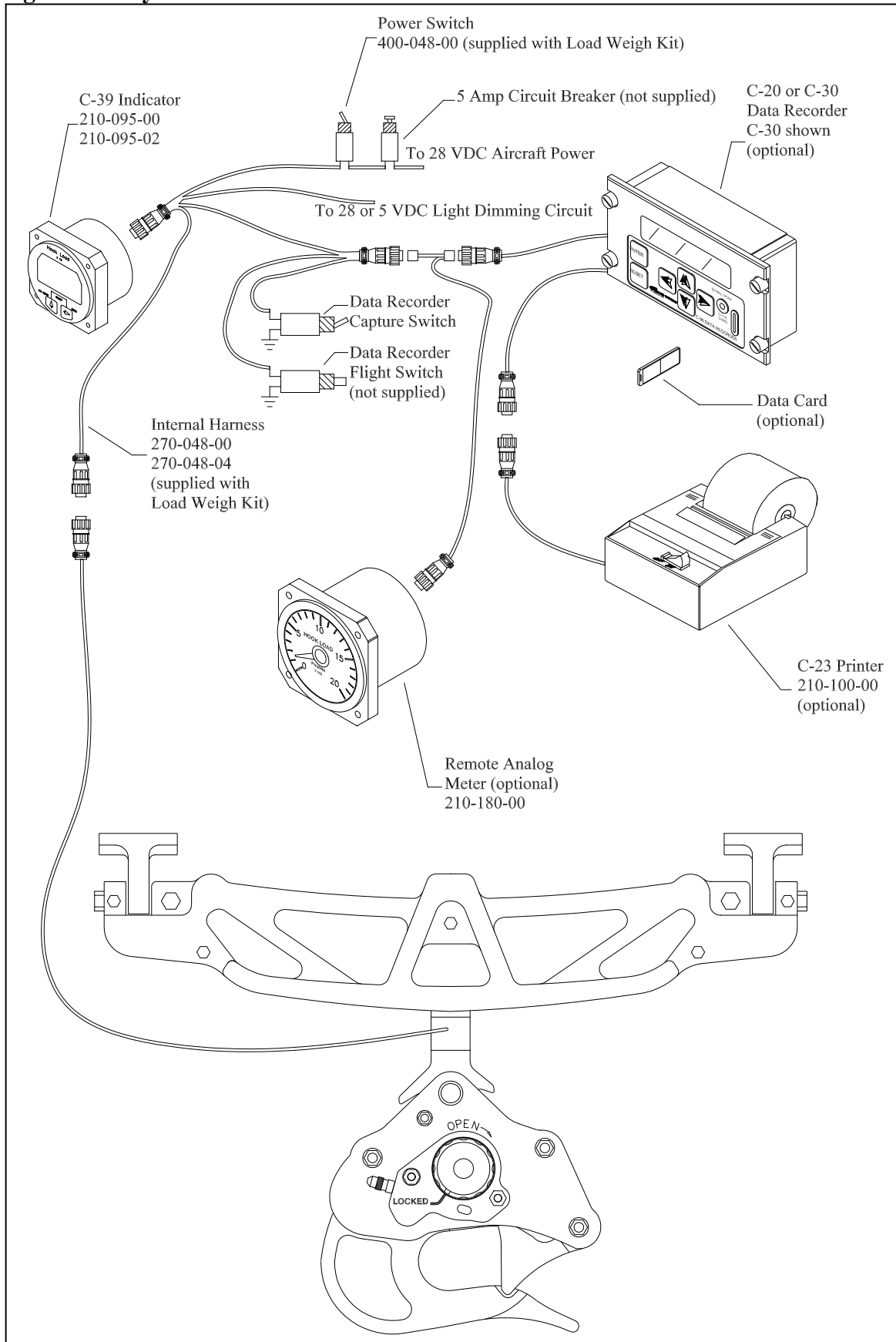



## *Section 3*

# **Cargo Hook Suspension System Operation Instructions**

## **Operating Procedures**

Prior to a flight involving external load operations perform the following:

1. Ensure that the Cargo Hook Suspension System has been properly installed and that the manual and electrical release cables do not limit the movement of the hook.
2. Be completely familiar with this manual, particularly the section covering the Cargo Hook rigging.
3. Be completely familiar with all Bell Helicopter Cargo Hook operating instructions.
4. Activate the electrical system and press the Cargo Hook release button to ensure the cargo hook electrical release is operating correctly. The Cargo Hook must relatch after release. If the hook does not relatch do not use the unit until the difficulty is resolved.

### **CAUTION**

*The release solenoid is intended to be energized only intermittently. Depressing the electrical release button continuously in excess of 20 seconds will cause the release solenoid to overheat, possibly causing permanent damage.*

5. Activate the release lever assembly located on the cyclic stick to test the cargo hook manual release mechanism. The mechanism should operate smoothly and the Cargo Hook must relatch after release. If the hook does not relatch do not use the unit until the difficulty is resolved.

See the trouble shooting table in Section 5 and the Bell Helicopter service instructions that cover the original Cargo Hook installation for additional instructions.

## Cargo Hook Rigging

Extreme care must be exercised when rigging a load to the Cargo Hook. If the load ring is too big it may work its way around the end of the load beam and be supported for a time on the keeper and then fall free. If the load ring is too small it may jam itself against the load beam during an attempted release. The following illustrations show recommended configurations and potential difficulties that must be avoided.



*The examples shown are not intended to represent all problem possibilities. It is the responsibility of the operator to assure the hook will function properly with the rigging.*

**Figure 3-1 Examples of Correct and Incorrect Cargo Hook Rigging**

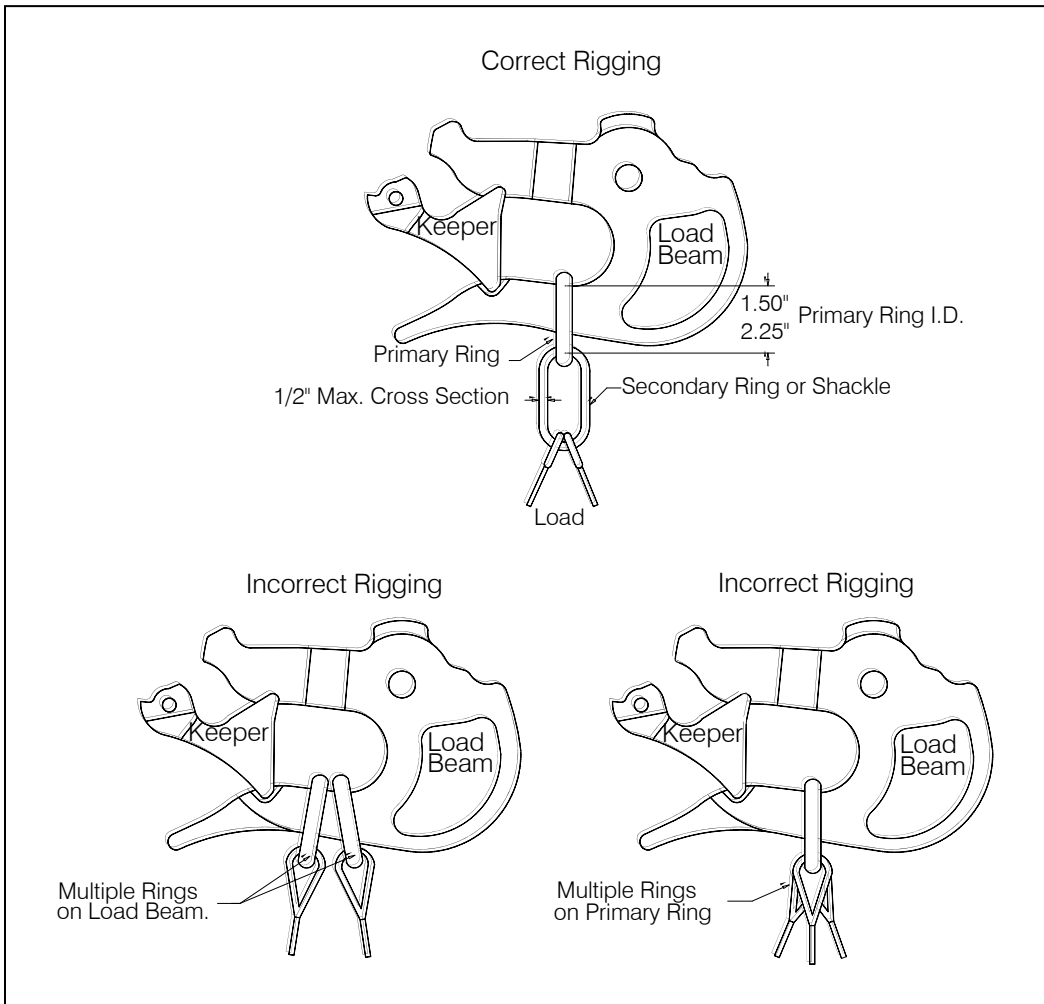

## Un-Commanded Release Due to Too Large of a Load Ring



*Load rings that are too large will cause an un-commanded release. The ring will flip over the end of the load beam and flip the keeper up and then fall free. Only correctly sized load rings must be used. See examples below.*

**Figure 3-2 Un-Commanded Release Due to Too Large of a Load Ring**

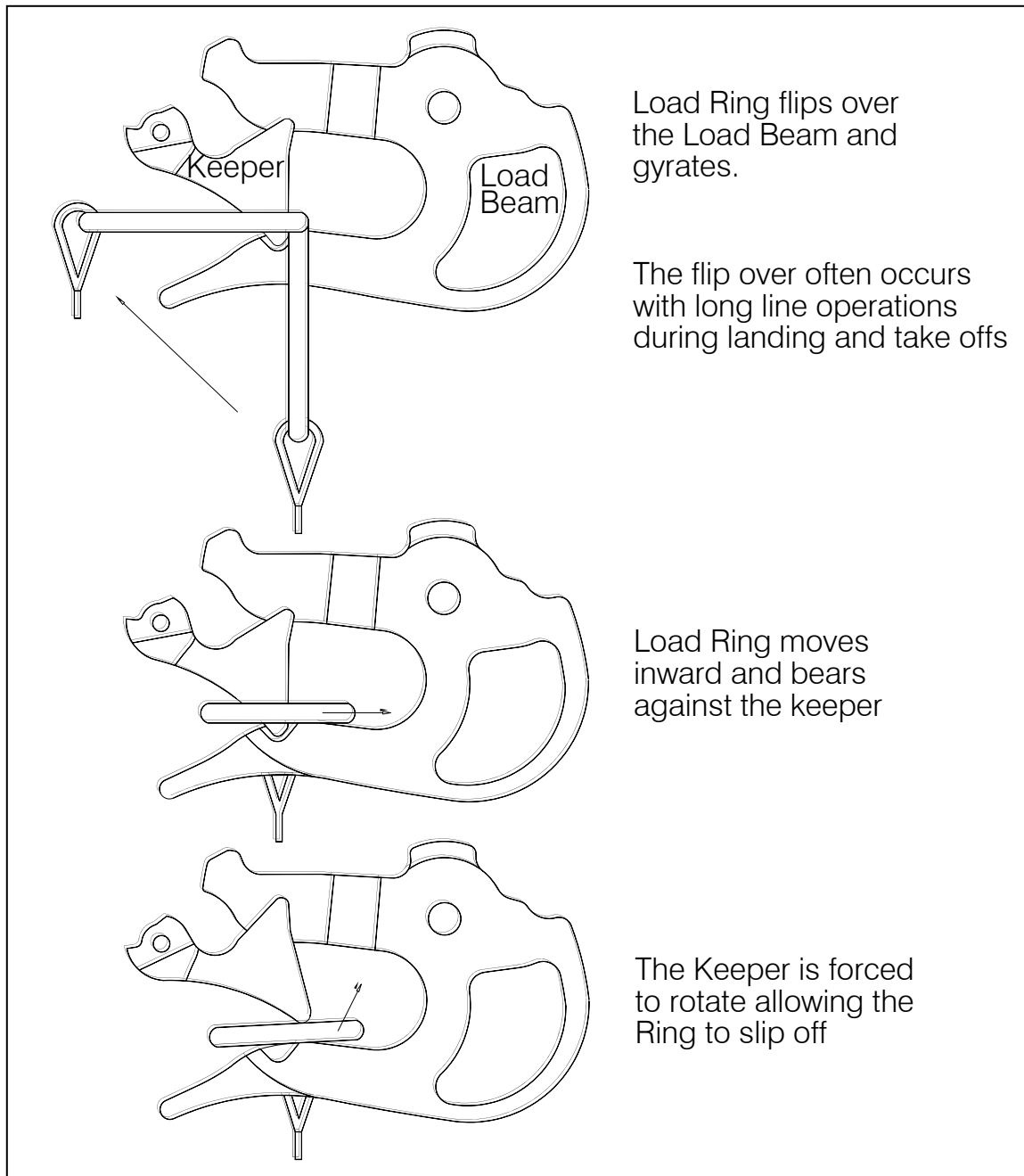

## Load Hang-Up Due to Too Small of a Load Ring or Multiple Load Rings



*Load rings that are too small or multiple load rings will hang on the load beam when the load is released. Only correctly sized load rings must be used. See examples below.*

Figure 3-3 Load Hang-Up Due to Too Small a Load Ring or Multiple Load Rings

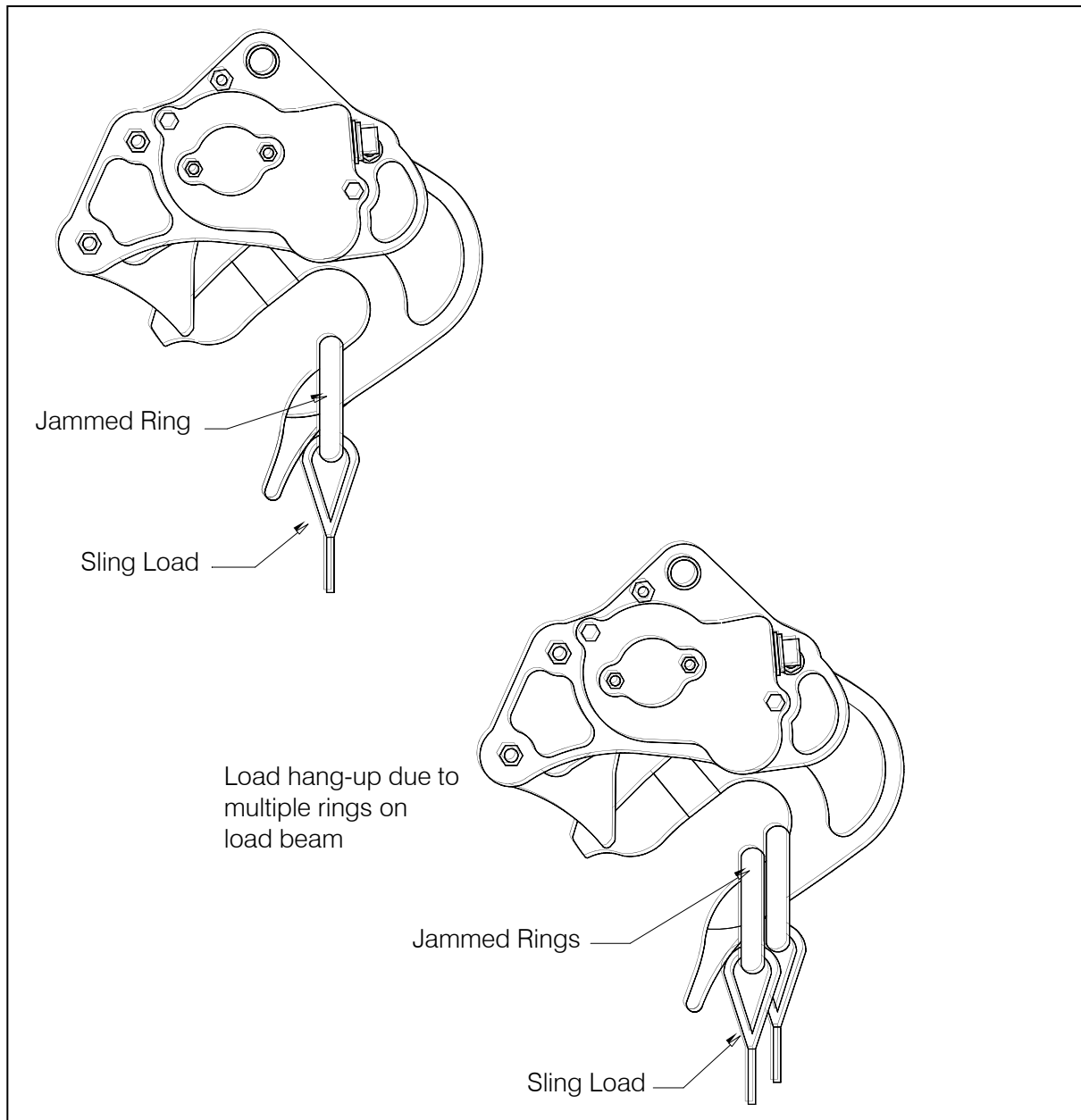

## Un-Commanded Release Due to Nylon Type Straps



*Nylon type straps (or similar material) must not be used directly on the cargo hook load beam as they have a tendency to creep under the keeper and fall free. If nylon straps must be used they should be first attached to a correctly sized primary ring. Only the primary ring should be in contact with the cargo hook load beam. See examples below.*

**Figure 3-4 Un-Commanded Release Due to Nylon Type Straps**

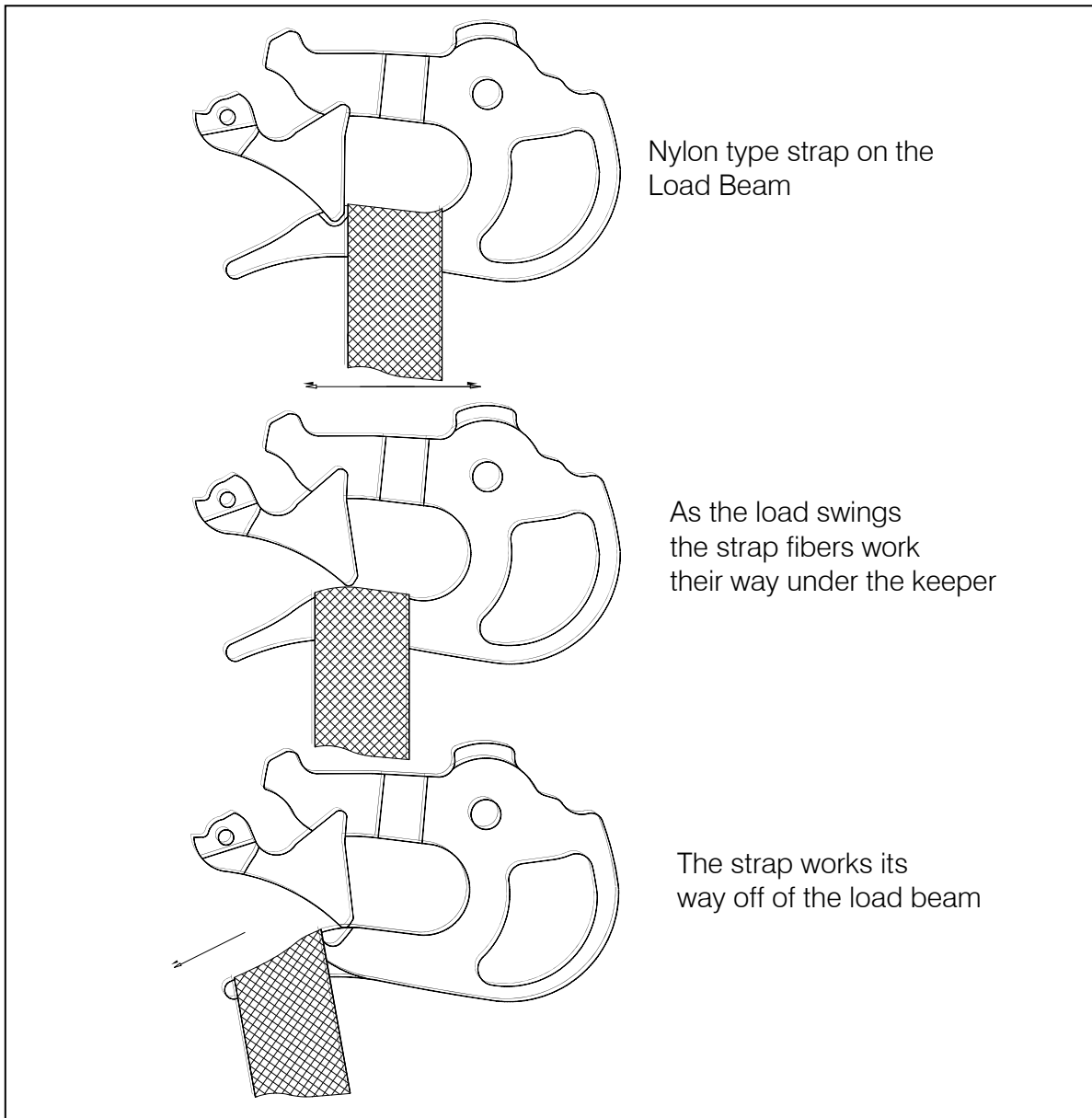

## Un-Commanded Release Due to Cable or Rope Type Straps



*Cable or rope type straps must not be used directly on the cargo hook load beam. Their braided eyes will work around the end of the load beam and fall free. If cable or rope is used they should be first attached to a correctly sized primary ring. Only the primary ring should be in contact with the cargo hook load beam. See examples below.*

**Figure 3-5 Un-Commanded Release Due to Cable or Rope Type Straps**

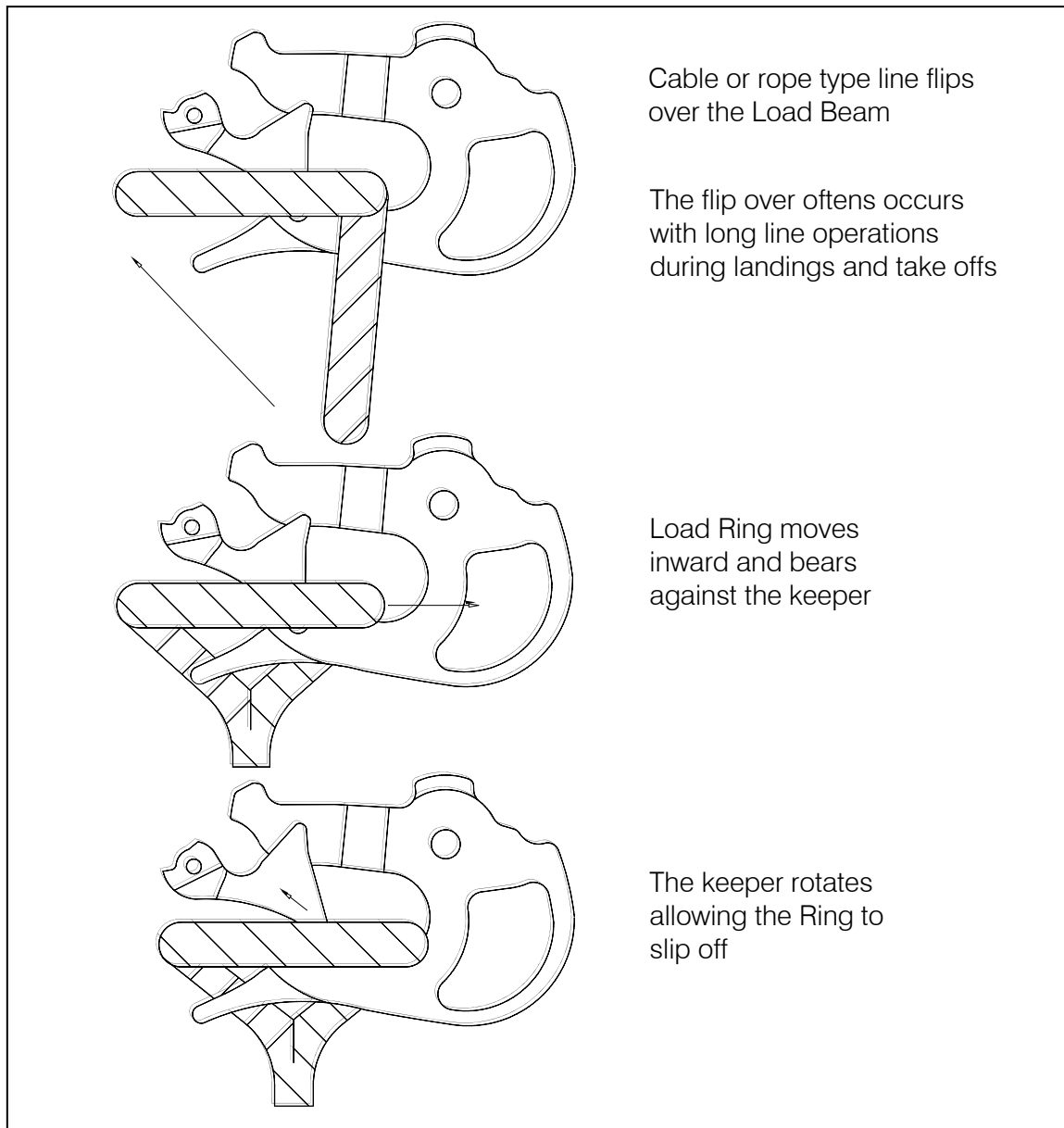

# Section 4

## Load Weigh System Operation Instructions

### Indicator Front Panel

The C-39 Indicator front panel includes the following features.

- The four 7 segment LCD digits show the weight on the Cargo Hook and displays various Setup information.
- The Legends clarify the digital display. i.e. when the LB Legend is turned on, the display will be pounds, etc.
- The Right button is used to Zero the display in the Run Mode and select the digit to be changed in the Setup Mode.
- The Left button is used to Un-Zero the display in the Run Mode and scroll the selected digit in the Setup Mode.

Figure 4-1 Front Panel

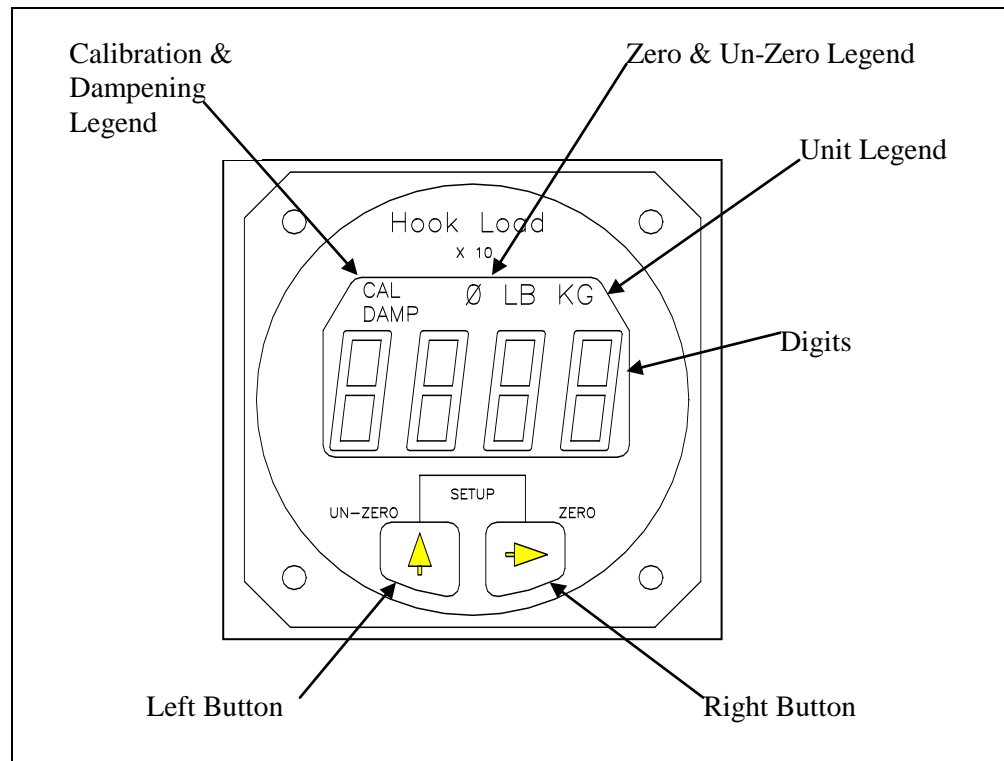

## The Run Mode

The C-39 Indicator has two operating modes, Run and Setup. The Run Mode is used to display the cargo hook weight and the Setup Mode is used to setup or configure the Indicator to the helicopter and to the Load Cell. When powered up, the Indicator always comes to life in the Run Mode.

After the Indicator has been correctly installed, power it up by activating the Load Weigh Circuit Breaker. The Indicator will go through a self diagnostic routine. During this routine the display will display all of the digits and legends. If a problem is found during the routine an Error Code will be displayed. For an explanation of Error Codes see the section *Error Codes*. After the diagnostic routine the display should look like this:

**Figure 4-2 After Diagnostic Routine**

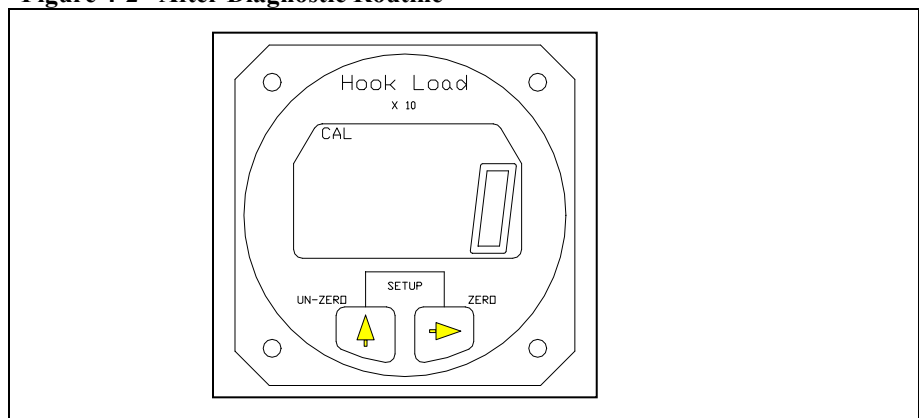

The illustration is of the Indicator in the Run Mode with no load on the hook. Note the LB legend displayed.

**Figure 4-3 LB Legend Displayed**

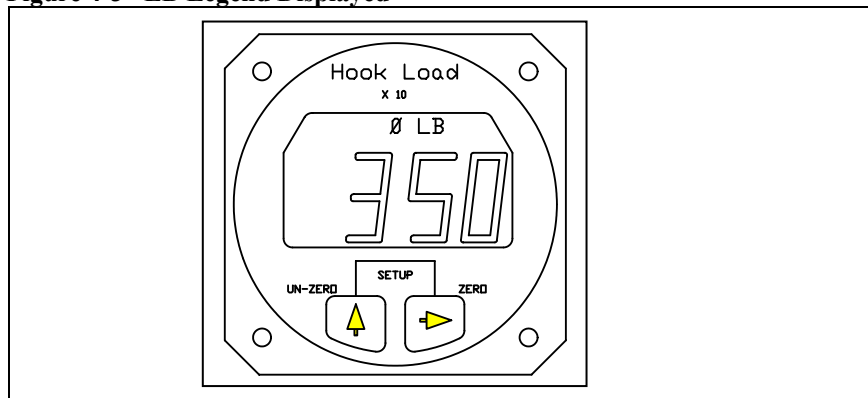

The illustration is a typical hook load reading. The display is 3,500 pounds, note the last digit is not displayed.



## To Zero or Tare the Display

The zero feature is used to zero or tare the weight on the Cargo Hook that is not wanted, such as the weight of a cargo net or long line. The Right button is used to zero the Indicator reading. When the Right button is pressed the display is zeroed. The zero legend is turned on and the zeroed number is stored in memory. If the Right button is pressed again, before the Un-zero button is pressed, the display blinks in response to the button closure. Zero is only available in the Run Mode.

Figure 4-4 Zeroing the Display

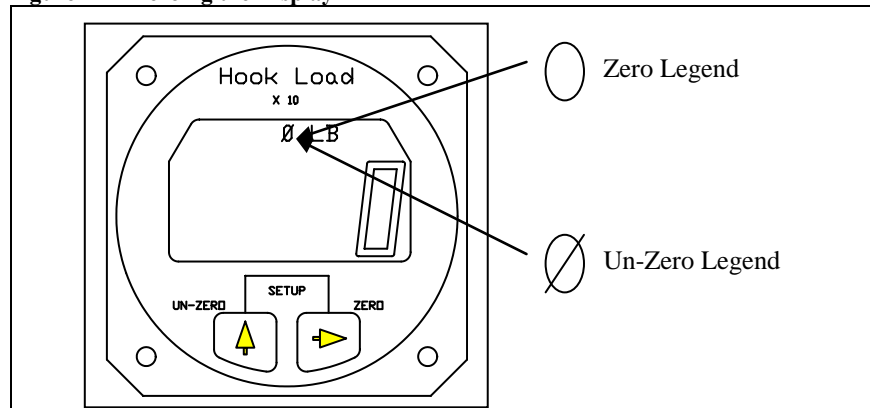

## To Un-Zero the Display

The Left button is used to add the zeroed value back into the current Indicator reading or Un-zero the display. When the Left button is pressed, the number previously zeroed is added to the current display and the Un-zero legend is turned on. If the Left button is again pressed before the zero button is pressed, the display blinks in response to the button closure. Un-Zero is only available in the Run Mode.

## Error Codes

Error Codes are the result of difficulties discovered during the Indicator diagnostic tests. Diagnostic tests occur at power up and during the execution of certain routines. Listed below is a matrix of the Error Code displays, their meaning and possible corrective action. Pressing either button will usually bypass the error code, however, the displayed information may be suspect.

**Table 4-1 Indicator Error Codes**

<b>DISPLAY</b>	<b>CAUSE</b>	<b>POSSIBLE CORRECTIVE ACTION</b>
Err 1	A/D or D/A circuit failure	Potential short in the optional analog meter cable. Clear short and power cycle the Indicator by turning the power to the Indicator off for a few moments. If Error Code continues, return the Indicator to the factory.
Err 2	NV Ram failure	Power cycle the Indicator; if Error Code continues, return the Indicator to the factory.
Err 3	NV Ram write failure	Re-enter data, if Error Code continues, return the Indicator to the factory.
Err 4	NV Ram busy failure	Power cycle the Indicator, if Error Code continues return the Indicator to the factory.

## The Setup Mode

The C-39 Indicator can be used with a wide range of helicopters and load cells. The Setup Mode on the Indicator matches the Indicator to the Load Cell and to the helicopter. This is done by entering data into the Indicator. Entered data includes the load cell Calibration Code, the units that the Indicator should read-out (pounds or kilograms), and several other items.

The Indicator has a group of Setup routines, arranged in menu form, that are used to configure the Indicator. Shown on the next page is a matrix of the Setup routines and a brief discussion of their function and how they are programmed. A complete discussion of each setup item is presented later in this section.

To enter the Setup Mode press both the Right and Left buttons at the same time while the Indicator is powered up and in the Run Mode. To exit the Setup Mode and return to the Run Mode, press both the buttons at the same time. If you are in a Setup routine and have started to change an entry, but you change your mind before completing the procedure, power cycle the Indicator to exit the Setup Mode and then go to the Run Mode without changing the item. The Indicator is power cycled by turning the Indicator power off for a few moments.

## The Setup Mode, continued

Table 4-2 Indicator Setup Routines

MENU	FUNCTION	DISPLAY
Press the Left button to scroll through the menu	Press the Right button to view or change the menu item.	To return to the Run Mode press both the Right and Left buttons at the same time.
DAMP	<u>Dampening Level</u> , sets the pilots preference for display dampening.	Blinking display is previously entered Dampening Level. Select the desired dampening level by pressing the Left button.
CODE	<u>Calibration Code</u> , matches the Indicator to the Load Cell.	Display is previously entered CAL Code. The Code is changed by selecting the digit to be changed with the Right button. The selected digit will blink. Change the blinking digit by pressing the Left button.
0 in	<u>Installation ZERO</u> , matches the Indicator to the installed Load Cell and to the helicopter. After this procedure the display will be zero when no load is on the Cargo Hook.	Display is a combination of load on the Load Cell, and normal load cell zero offset. Remove all weight from the installed Load Cell except the Cargo Hook, and press any button to complete the procedure and return to the Run Mode.
LOAD	<u>Load</u> , is used to calibrate the system by lifting a known load.	No previous display is shown. Enter the known load using the Right button to select the digit to be changed and Left button to enter the number. Known load is entered "X 10" i.e.; 5000 kilograms is entered as 500. After the known load is entered, press both buttons at the same time and lift the known load. When the load is stabilized press either button. A new Calibration Code will be calculated and the known load will be displayed. This completes the procedure.
Scale	<u>Scale</u> , matches the analog output of the Indicator to an optional remote analog meter.	Display is previously entered number. To change the number use the Right button to select a digit, use the Left button to scroll the digit to the desired number. Entry is times 10.
LB KG	<u>Units</u> , selects the Indicator units (pounds or kilograms).	Display is previously selected unit. To change the unit, use the Left button.
XX - V	<u>Version</u> , is the revision level of the Indicator hardware and software.	Version is for information only, it cannot be changed.

## Indicator Dampening

The Damp or dampening routine allows the pilot to adjust the Indicator dampening level to his preference. The dampening routine is a program that stabilizes the Indicator reading. It offers a trade-off between Indicator responsiveness and stability. Ten dampening levels are available, from 0 through 9. At level 0 the display responds to the slightest change in weight. However, if the load bounced even slightly, the display digits would respond instantly, making the display look unstable. With a dampening level of 9, the display would be stable under the most turbulent conditions, however, it would take several seconds for the display to respond to a change in weight. The ideal dampening level will depend on the flying conditions. A mid range setting of 5 or 6 is usually adequate.

### To Look at or Change the Dampening Level

With the Indicator powered up and in the Run Mode, press both buttons at the same time to go to Setup. Scroll through the menu, using the Left button, until the word DAMP is displayed. To look at or change the Dampening Level press the Right button. The display should look like this:

**Figure 4-5 Changing Dampening Level**

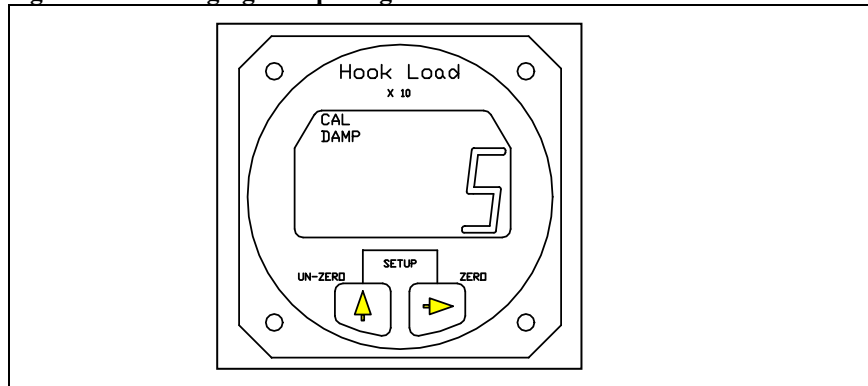

The CAL and the DAMP legend is turned on and the previously set dampening level is displayed. To return to Run without changing the current dampening level press both the Right and Left buttons at the same time. To change the dampening number, use the Left button to scroll the blinking digit to the desired number. After the selection has been made press both the Right and Left buttons at the same time to return to Run.

## Indicator Calibration

The Calibration Code, or CAL code, is a mandatory input. The Indicator will not accurately display the load without the correct Calibration Code. The Calibration Code scales the signal from the Load Cell.

If the C-39 Indicator was supplied as part of a Load Weigh System, the Calibration Code will have been entered into the Indicator by the factory, however, it should be confirmed. If the Indicator is to be mated to a different Load Cell, it must be calibrated before use. Calibration can be done by entering a known Calibration Code or by lifting a known load and having the Indicator calibrate itself. Both options are discussed below.

## To Look at or Change the Calibration Code

With the Indicator powered up and in the Run Mode, press both buttons at the same time to go to Setup. Scroll through the menu until the word CODE is displayed, then press the Right button. The display should look like this:

**Figure 4-6 Changing the CAL Code**

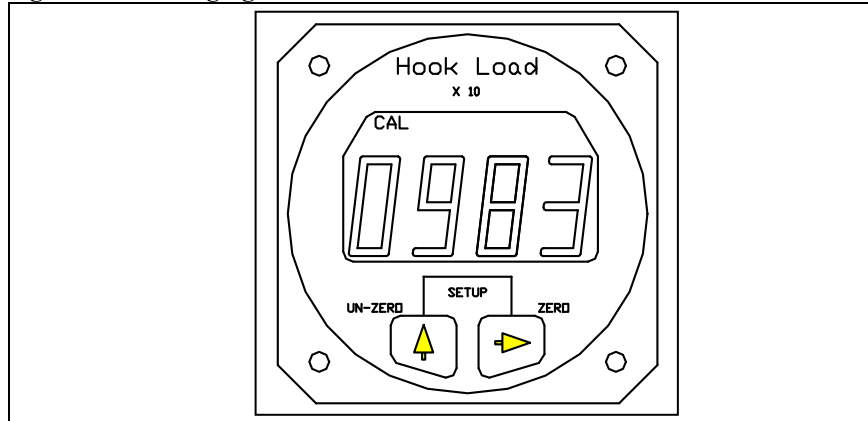

The CAL legend is turned on and the previously entered or computed Calibration Code is displayed. To return to Run without changing the CAL Code, press both the Right and Left buttons at the same time. To change the Calibration Code, use the Right button to select the digit to be changed, then use the Left button to scroll the blinking digit to the desired number. When the Calibration Code has been entered, press both the Right and Left button at the same time to return to Run.

# NOTICE

*Depending on the type of Load Cell, the Calibration code could be a 3 or 4 digit number. If the Calibration Code is a 3 digit number a leading zero (0) must be used. For example if a Load Cell had a CAL Code of 395 it would be entered as 0395*

If the load cell Calibration Code is not known or as a cross check, the Indicator can generate the Calibration Code. This is done by entering the weight of a known load into the Indicator LOAD routine and then lifting the load. See the section *Calibration by Lifting a Known Load*.

## Installation Zero

Installation zero is a routine that matches the Indicator to the ***INSTALLED*** Load Cell. It adjusts the Indicator reading to compensate for the weight of the Cargo Hook on the Load Cell and whatever zero offset is built into the Load Cell. The Installation Zero procedure is not mandatory. If done the Indicator will read zero when the Un-Zero button is pressed and there is no weight on the Cargo Hook. If the Installation Zero is not done, the Indicator will show the weight of the Cargo Hook plus the value of the Load Cell zero offset.

### To Run the Installation Zero Routine

With the Indicator powered up and in the Run Mode, press both buttons at the same time to go to Setup. Scroll through the menu until the symbol "0 in" is displayed, then press the Right button. The CAL legend will be turned on and the current weight on the Cargo Hook will be displayed and blinking. Remove any weight that is not to be zeroed out and press either button to complete the procedure and return to the Run Mode.

### Calibration by Lifting a Known Weight

Calibration by lifting a known weight is a Setup routine that calculates the Calibration Code for the Load Cell attached to the Indicator. It is useful if the load cell Calibration Code is not known or as a cross check to the accuracy of a known Calibration Code. The procedure is done by entering the known weight into the Indicator and then lifting the weight. This procedure can be done in the shop or on the helicopter. The accuracy of the procedure is directly related to the weight of the known load. If for example the procedure was done with a 1,000 pound load that was assumed to weigh only 900 pounds, all subsequent lifts would be displayed 10% light.



*Be sure to include the weight of everything between the Cargo Hook and the load, i.e. the cable, net, dirt, etc*

The closer the known load approaches the lifting capacity of the helicopter, the more accurate the calculated Calibration Code will be.

## Calibration by Lifting a Known Weight, continued

### To Run the Calibration by Lifting a Known Weight Routine

With the Indicator powered up and in the Run Mode, press both buttons at the same time to go to Setup. Scroll through the menu until the word LOAD is displayed, then press the Right button. The display should look like this:

**Figure 4-7 Running CAL Routine**

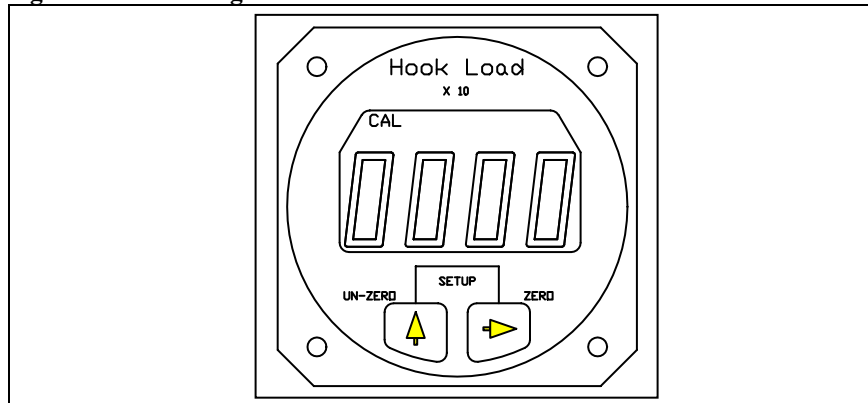

The CAL legend is turned on and the first digit is blinking. The previous load is not displayed. At this point if you wish to return to the Run Mode without changing the Calibration Code, power cycle the Indicator. At this point it is not possible to return to the Run Mode without changing the Calibration Code by using the buttons on the Indicator front panel.

To proceed with the procedure, use the Right button to select the digit to be changed, then use the Left button to scroll the blinking digit to the desired number. Note that the known weight is entered "X 10"; a 1000 pound load is entered as 100. When the known load has been entered, press both the Right and Left button at the same time. The display will look like this:

**Figure 4-8 Entering Load in CAL Routine**

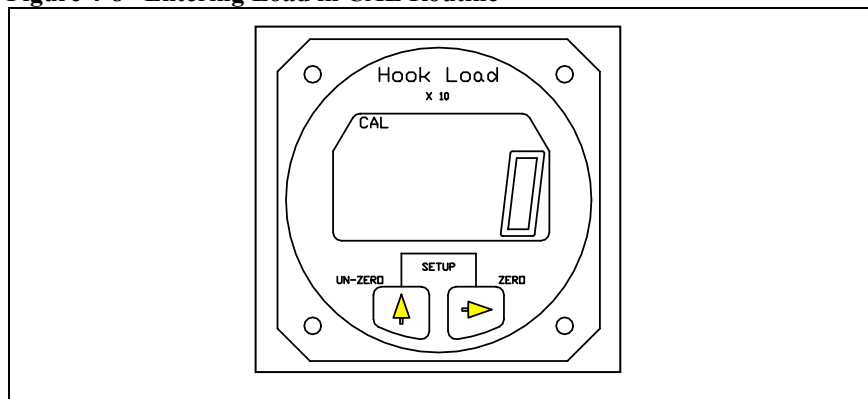



## Calibration by Lifting a Known Weight, continued

The CAL legend and the digits will be blinking. Again, at this point if you wish to return to the Run Mode without changing the Calibration Code, power cycle the Indicator. It is not possible to return to the Run Mode by using the buttons on the Indicator front panel without changing the Calibration Code. If you wish to proceed, lift the known load and when it is stabilized, press either button to complete the procedure. The Indicator will display the load. This ends the procedure. The Indicator is now calibrated to the Load Cell. It is a good practice to go to the Code routine and record the new Calibration code for later reference.

## Setting the Scale for a remote analog meter

The Scale routine is used when a user supplied analog meter is connected to the Indicator. It is used to match or calibrate the analog meter to the Indicator. The Indicator outputs a 0 to 5 VDC analog signal which is proportional to the Load Cell load. The Scale number tells the Indicator at what point in pounds or kilograms it should reach the 5 VDC output. If for example a 5 volt analog meter is used and its full scale reading is 10,000 pounds, the number entered into the Indicator Scale routine would be 1000 (the number is entered X 10). This number tells the Indicator that it should output the proportional 0 to 5 VDC signal between zero pounds and 10,000 pounds.

The Scale number does not affect Onboard Slave Meters, P/N 210-106-00 or 210-180-00. This number only affects user supplied instruments connected to the analog out signal.

## To Look at or Change the Scale

With the Indicator powered up and in the Run Mode, press both buttons at the same time to go to Setup. Scroll through the menu until the word SCALE is displayed, then press the Right button. The display should look like this:

**Figure 4-9 Changing the Scale**

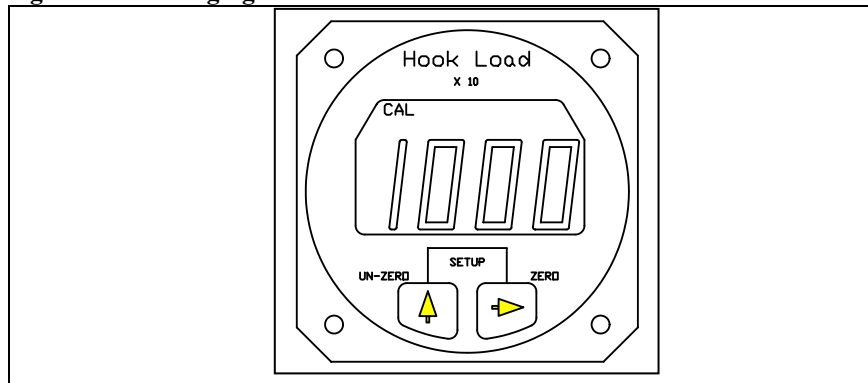

### To Look at or Change the Scale, continued

The CAL legend is turned on and the previously set Scale number is displayed. To return to Run without changing the Scale, press both the Right and Left button at the same time. To change the Scale number, use the Right button to select a digit to be changed, then use the Left button to scroll the blinking digit to the desired number. When the complete Scale number has been entered, press both the Right and Left button at the same time to return to Run.

### Select KG or LB Units

The units routine sets the display to read in pounds (LB) or kilograms (KG).

### To look at or change the Units

With the Indicator powered up and in the Run Mode, press both buttons at the same time to go to Setup. Scroll through the menu until the word LB or KG is displayed, then press the Right button. The display should look like this:

**Figure 4-10 Changing the Units**

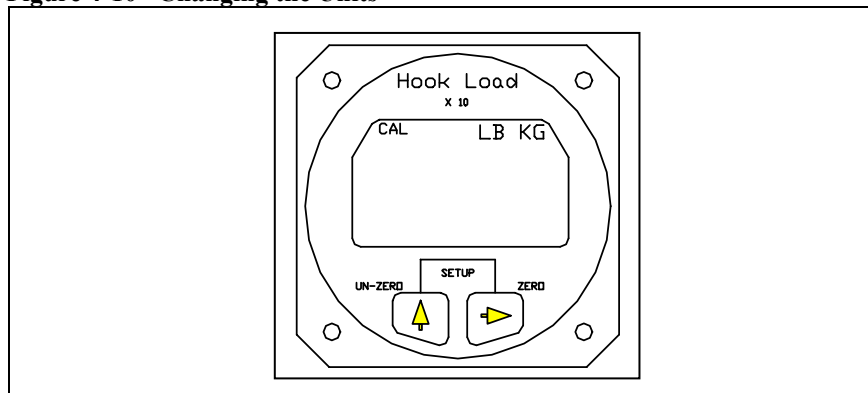

The CAL legend is turned on and the previously set unit is displayed. To return to Run without changing the units, press both the Right and Left button at the same time. To change the units press the Left button. When the selection has been made, press both the Right and Left button at the same time to return to Run.

**NOTICE**

*The selected units are displayed when in the Run Mode.*

## Indicator Version

The Version routine displays the Indicator's hardware and software revision levels. Version is set at the factory and cannot be changed.

**Figure 4-11 Looking at Indicator Version**

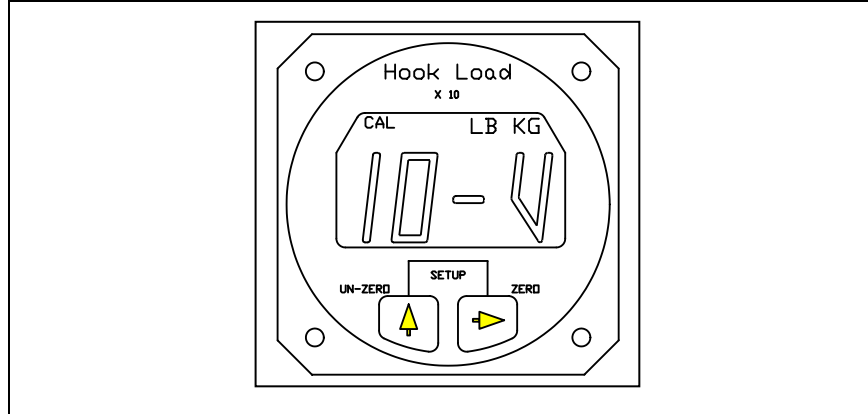

This page intentionally left blank.

# Section 5

## Maintenance

Refer to Cargo Hook Component Maintenance Manual (CMM) 122-002-00 for detailed maintenance information for the cargo hook.

### Storage Instructions

Clean the Cargo Hook Suspension System components thoroughly before packaging. Pack the unit in a heat-sealable package. If the unit is to be stored for long periods in a tropical climate it should be packed in a reliable manner to suit local conditions. Refer to relevant MIL specifications. After the Cargo Hook has been repaired or stored for an extended period of time it must be subjected to the Acceptance Test Procedure per CMM 122-002-00.

Package the unit in a suitable fiberboard box and cushion the unit to prevent shifting. Seal the fiberboard box with tape and mark the box with the contents and date of packaging.

### Preventive Maintenance

Remove caked-on dirt from the Cargo Hook Suspension System components with a brush and clean exposed surfaces with a mild solvent. Thoroughly dry all surfaces.

### Inspection

The scheduled inspection intervals noted below are maximums and are not to be exceeded. If the cargo hook suspension system is subjected to unusual circumstances, extreme environmental conditions, etc., it is the responsibility of the operator to perform the inspections more frequently to ensure proper operation.

---

**Annually or 100 hours of external load operations, whichever comes first, inspect the cargo hook and suspension per the following.**

---

**NOTICE**

*Hours of external load operations should be interpreted to be (1) anything is attached to the primary cargo hook (whether or not a useful load is being transported) and (2) the aircraft is flying. If these conditions are NOT met, time does NOT need to be tracked.*

## Inspection, continued

1. Activate the helicopter electrical system and press the cargo release button to ensure the cargo hook electrical release is operating correctly. The cargo hook must release. If the hook does not release or re-latch, do not use the unit until the problem is corrected.

# CAUTION

*Pressing the cargo electrical release button continuously in excess of 20 seconds will cause the cargo hook electrical release solenoid to overheat, possibly causing permanent damage.*

2. Activate the manual release system by pulling the release handle in the cockpit. The cargo hook must release. If the hook does not release or re-latch, do not use the unit until the problem is corrected.
3. Move the cargo hook and the suspension system throughout their full ranges of motion to ensure the manual and electrical release cables have enough slack. The cables must not be the stops that prevent the cargo hook or suspension from moving freely in all directions.
4. Move the cargo hook back and forth on the beam to ensure that it rolls freely and that there are no obstructions within the beam.
5. Rotate the beam assembly about its pivot point throughout its full range of motion and verify it moves freely.
6. Visually check for presence and security of fasteners and electrical connections.
7. Visually inspect the electrical cables for damage and security.
8. Visually inspect the manual release cable for damage and security.
9. Visually inspect for corrosion on the exterior of cargo hook and suspension system components (refer to Table 5-2 for limits for suspension components). Corrosion on the cargo hook side plates is cause for immediate overhaul. Additionally, any exfoliation corrosion in the upper attach lug area of the cargo hook is cause for immediate replacement of the side plate. Refer to the Cargo Hook CMM 122-002-00 for cargo hook assembly/disassembly.

# Overhaul

It is recommended that only minor repairs be attempted by anyone other than the factory. It is recommended that the Cargo Hook Suspension System be returned to the factory for overhaul or when any of the components are in need of major repair.

The instructions in this manual are provided for the benefit of experienced aircraft maintenance facilities capable of carrying out the procedures. They must not be attempted by those lacking the necessary expertise.

---

**Time Between Overhaul (TBO): 1000 hours of external load operations or 5 years, whichever comes first.**

---

Refer to CMM 122-002-00 for overhaul information for the Cargo Hook.

At overhaul, remove the suspension system from the helicopter, and disassemble per the following instructions and inspect. Refer to Figure 5-1 for part identification.

1. With the Cargo Hook Suspension System removed from the aircraft separate the Cargo Hook from the Beam Assembly at the Carriage.
2. Separate the two Beam Halves (6) by removing the fasteners (16, 17, & 18)
3. Remove the Carriage Assembly from the Beam and separate the bearings (22), shafts (19), and the thrust buttons (23) from the Carriage (20).
4. Remove the bearings (7) from the pillow block (9) by conventional means.

## Cargo Hook Suspension System Overhaul Inspection

Carefully inspect the detail parts in accordance with the instructions in Table 5-4. Inspect the parts in a clean, well lighted room.

Inspect bearings and the shafts they run on for wear and corrosion. Pitting, corrosion or roller dents on shafts is cause for rejection. Maximum permissible bushing clearances are .010” on diameter.

Perform magnetic particle inspection in accordance with ASTM E1444 and MIL-STD-1907, Grade A on the parts listed below. No cracks are permitted in any of these parts.

Carriage (21)      Trunnion Pins (3)      Shafts (19)  
Load Cell (25)

Perform penetrant inspection per ASTM E1417 and MIL-STD-1907, Grade A on the parts listed below. No cracks are permitted in any of these parts.

Beam Half (6)      Pillow Blocks (2)

## Cargo Hook Suspension System Inspection continued

**Table 5-1 Cargo Hook Suspension System Inspection**

<b>Part</b>	<b>Visually Inspect for</b>	<b>Remedy</b>
Threaded parts	Replace all threaded parts	Replace
Pillow Blocks	Dents, nicks, cracks, gouges corrosion or scratches	Repair minor, replace if otherwise damaged
Beam half	Dents, nicks, cracks, gouges corrosion or scratches	Repair minor, replace if otherwise damaged
Wear Plate	Dents, nicks, cracks, gouges corrosion or scratches	Repair minor, replace if otherwise damaged
Trunnion Pins	Dents, nicks, cracks, gouges corrosion or scratches	Repair minor, replace if otherwise damaged
Carriage	Dents, nicks, cracks, gouges corrosion or scratches	Repair minor, replace if otherwise damaged
Carriage Shafts	Dents, nicks, cracks, gouges corrosion or scratches	Repair minor, replace if otherwise damaged
Thrust Buttons	Nicks, cracks, scratches or wear	Replace if flange thickness is less than .050
Thrust Spacers	Nicks, cracks, scratches or wear	Replace
Manual Release Cable	Roughness, binding, looseness, or corrosion	Replace
Electrical Release Cable	Damaged cable and connectors	Replace
Nameplate	Mutilation or illegibility	Replace
Springs	Cracks and deformation	Replace
Bearings	Roughness, binding, looseness, or corrosion	Replace
Bushings	Cracks, deformation, wear & corrosion	Replace
Solenoid	Burning, check resistance with ohmmeter	Replace if burnt or if resistance is outside 2.0 to 2.5 ohm range
Bumpers	Wear and rubbing on load beam	Replace
Cargo Hook Case and cover assembly	Dents, nicks, cracks, gouges, or scratches	Repair minor, replace if otherwise damaged
Electrical wiring	Deterioration	Replace
Electrical connector	Loose, missing, or mutilated contact pins, cracked case, or worn insulator	Replace
Load beam	Gouges or burrs on wearing surfaces	Remove burrs, replace if gouged



## Beam Assembly Procedures

1. Replace all fasteners that have been removed at disassembly.
2. Assemble the shafts (19), bearings (22) and the thrust buttons (21) to the carriage (21) or load cell (25).
3. Install the wear plate (23) and the bumper (8) to the beam half (6), secure the fasteners.
4. Attach to aircraft as shown in Figure 2-5.

## Cargo Hook Suspension System Parts

Figure 5-1 Cargo Hook Suspension System Parts

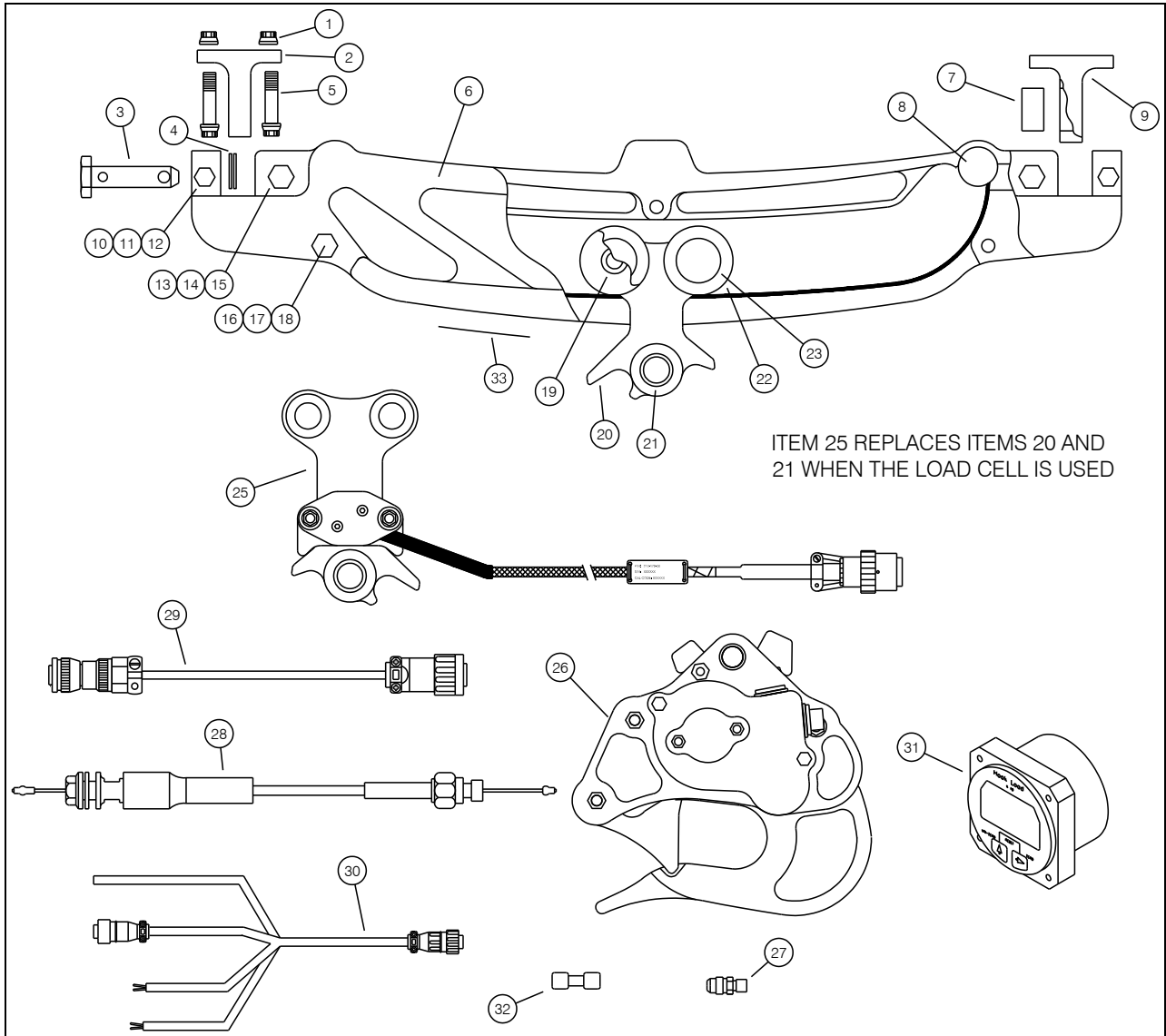

## Cargo Hook Suspension System Parts continued

**Table 5-2 Cargo Hook Suspension System Parts**

ITEM	PART NO.	DESCRIPTION	QTY
1	510-234-00	Nut	4
2	232-030-02*	Pillow Block Assembly	2
3	290-370-00	Trunnion Pin	2
4	290-374-00	Thrust Spacers	10
5	510-235-00	Bolt	4
6	290-368-00	Beam Half	2
7	517-012-00	Bearing	2
8	290-372-00	Bumper	4
9	290-371-02	Pillow Block, W/O bearing	2
10	510-229-00	Bolt	2
11	510-095-00	Washer	2
12	510-102-00	Nut	2
13	510-114-00	Nut	2
14	510-100-00	Washer	2
15	510-230-00	Bolt	2
16	510-231-00	Bolt	3
17	510-100-00	Washer	3
18	510-114-00	Nut	3
19	290-366-00	Shaft	2
20	290-364-00	Carriage Bushing	1
21	290-369-00	Carriage	1
22	517-011-00	Bearing	4
23	290-367-00	Thrust Button	4
24	290-373-00	Wear Plate	2
25	210-179-01**	Load Cell Assembly	1
26	528-017-00	Cargo Hook	1
27	290-331-00	Release Fitting	1
28	268-004-01	Manual Release Cable	1
29	270-095-00	Electrical Release Cable	1
30	270-048-04	Load Weigh Harness Assembly	1
31	210-095-00	C-39 Indicator	1
32	600-006-00	Release Cable Disconnect	1
33	215-105-00	External Load Limit Placard	1

\* Per Service Bulletin 159-020-00, Pillow Block Assembly P/N 232-030-01 was changed to 232-030-02. The -02 Pillow Block Assembly configuration can be identified by a “-02” engraving (see Figure 5-2).

\*\* P/N 210-179-01 supersedes P/N 210-179-00. These P/Ns are interchangeable.

## Cargo Hook Suspension System Parts continued

Figure 5-2. Identification of Pillow Block Assembly

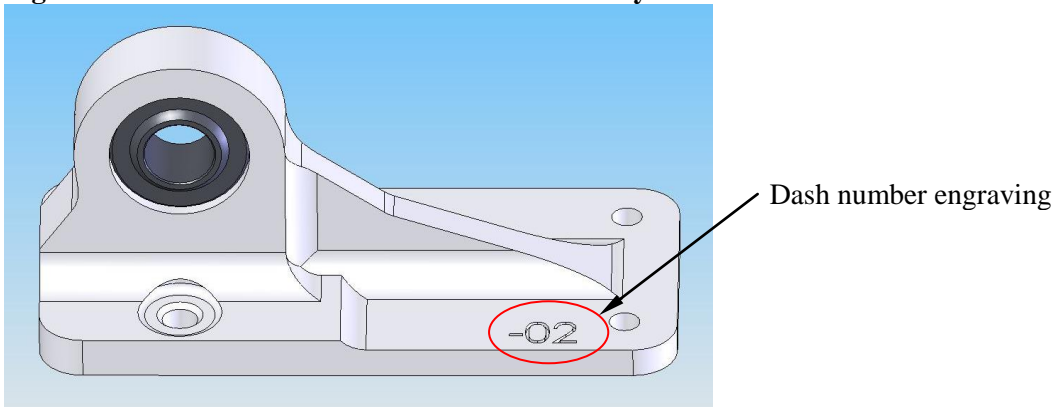

# Trouble Shooting

**Table 5-3 Trouble Shooting**

DIFFICULTY	PROBABLE CAUSE	CORRECTIVE ACTION
Cargo hook does not operate electrically, manual cable release operates normally.	Open electrical circuit, faulty wiring, circuit breaker, switch or solenoid	Disconnect cable from electrical connector on Cargo Hook. Using multimeter, check for 2.0 to 2.5 ohms between pins A and B of electrical connector. If open indication is obtained, check solenoid for 2.0 to 2.5 ohms resistance, per CMM 122-002-00. Replace solenoid if required.
Cargo hook does not operate electrically or manually.	Defective internal mechanism	Disassemble, and inspect internal mechanism for binding, jamming, and worn or broken parts per CMM 122-002-00. Repair as needed.
Cargo hook operates electrically, but not manually.	Defective manual release cable Defective manual release system	Check manual release cable and cable connection to Cargo Hook. Correct any defects.
Load beam fails to relatch after load release.	Defective latch mechanism	If load beam does not swing back up, check return spring, pin, and arm assembly per CMM 122-002-00. Replace defective part.
Cargo hook manual release pull-off exceeds 8 Lbs. (at the hook).		Check operation of unit using manual release knob. If knob force is high, disassemble hook per CMM 122-002-00. Check pivot points for excessive friction and lubricate. Check contact surfaces between latch and load beam.
Circuit breaker opens when Cargo Hook is energized.	Short in the system, faulty wiring, circuit breaker or solenoid	Check for shorts to ground. Check solenoid per CMM 122-002-00, Repair or replace defective parts See Table 2-1
The cargo hook will not roll smoothly back and forth on the beam.	Obstructions in the beam, bad bearings in the beam	Remove obstructions, replace bearings and associated parts as required.
The beam will not pivot on pillow block bearings	Obstructions or bad bearings in the beam	Obstructions or bad bearings in the beam
Circuit breaker opens when the circuit to Load Weigh System is energized.	Short in the system, faulty wiring, circuit breaker or switch.	Repair or replace defective wiring, circuit breaker and switch.
Load Weigh Indicator does not light up.	Faulty wiring, circuit breaker or switch.	Check the power switch, circuit breaker and wiring. If this doesn't help, return the unit to the factory.

## Trouble Shooting, continued

**Table 5-3 Trouble Shooting, continued**

DIFFICULTY	PROBABLE CAUSE	CORRECTIVE ACTION
Where Am I? (Lost when programming the Indicator)		Turn the Indicator power off for a few moments. When it comes to life it will be in the Run mode.
Indicator displayed load is incorrect.	Incorrect Calibration Code.	Insure the correct Calibration Code has been entered.
Indicator displayed load is not stable.	Dampening level is too small.	Adjust the Dampening level to a larger number.
Indicator displayed load takes too long to change the reading when the load is changed.	Dampening level is too large.	Adjust the Dampening level to a smaller number.
Do not recognize the Indicator displayed numbers.	NV Ram failure, A/D or D/A circuit failure.	Refer to <i>Error Codes</i> in section 3.
Indicator does not change with changing hook loads.	Defective load cell or damaged internal harness.	Check for damaged internal harness, replace load cell.

## Instructions for Returning Equipment to the Factory

If an Onboard Systems product must be returned to the factory for any reason (including returns, service, repairs, overhaul, etc) obtain an RMA number before shipping your return.



*An RMA number is required for all equipment returns.*

- To obtain an RMA, please use one of the listed methods.
  - Contact Technical Support by phone or e-mail ([Techhelp@OnboardSystems.com](mailto:Techhelp@OnboardSystems.com)).
  - Generate an RMA number at our website: <http://www.onboardsystems.com/rma.php>
- After you have obtained the RMA number, please be sure to:
  - Package the component carefully to ensure safe transit.
  - Write the RMA number on the outside of the box or on the mailing label.
  - Include the RMA number and reason for the return on your purchase or work order.
  - Include your name, address, phone and fax number and email (as applicable).
  - Return the components freight, cartage, insurance and customs prepaid to:

Onboard Systems  
13915 NW 3rd Court  
Vancouver, Washington 98685  
USA  
Phone: 360-546-3072

# Section 6 Certification

## FAA STC

United States of America  
Department of Transportation—Federal Aviation Administration  
**Supplemental Type Certificate**

*Number* SR00724SE

*This certificate, issued to* **Onboard Systems  
13915 NW 3rd Court  
Vancouver, WA 98685**

*certifies that the change in the type design for the following product with the limitations and conditions therefor as specified hereon meets the airworthiness requirements of Part 6 of the Civil Air Regulations.*

*Original Product—Type Certificate Number:* H2SW  
*Make:* Bell  
*Model:* 206L-1, 206L-3, 206L-4 and 407

*Description of the Type Design Change:* Fabrication of Onboard Systems Model 200-249-00 (without load weigh) or 200-250-00 (with load weigh) cargo hook suspension system in accordance with FAA Approved Onboard Systems Master Drawing List No. 155-049-00, Revision 8, dated April 20, 2007, or later FAA approved revision; and installation of this cargo hook suspension system in accordance with FAA approved Onboard Systems Owner's Manual No. 120-085-00, Revision 7, dated April 16, 2007, or later FAA approved revision. Inspect this cargo hook kit in accordance with Onboard Systems Owner's Manual No. 120-085-00, Revision 7, dated April 16, 2007, or later FAA approved revision.

*Limitations and Conditions:* Approval of this change in type design applies to only those Bell model rotorcraft listed above, which were previously equipped with an FAA approved installation of Bell Auxiliary Equipment Kit – Cargo Hook Provisions P/N 206-706-341-7, -9, -103, -111, or -113. This approval should not be extended to rotorcraft of these models on which other previously approved modifications are incorporated unless it is determined by the installer that the relationship between this change and any of those other previously approved modifications, including changes in type design, will introduce no adverse effect upon the airworthiness of that rotorcraft. Modified rotorcraft must be operated in accordance with an FAA approved copy of Onboard Rotorcraft Flight Manual Supplement (RFMS) No. 121-045-00, Revision 0, dated August 9, 2007, or later FAA approved revision. A copy of this Certificate and FAA approved RFMS must be maintained as part of the permanent records of the modified rotorcraft.

If the holder agrees to permit another person to use this certificate to alter the product, the holder shall give the other person written evidence of that permission.

*This certificate and the supporting data which is the basis for approval shall remain in effect until surrendered, suspended, revoked, or a termination date is otherwise established by the Administrator of the Federal Aviation Administration.*

*Date of application:* May 12, 1999  
*Date of issuance:* August 4, 1999  
*Date reissued:*  
*Date amended:* January 13, 2003, August 10, 2007

  
By direction of the Administrator  
*Kenneth Paulsen*  
(Signature)  
Acting Manager, Seattle Aircraft Certification Office  
(Title)

Any alteration of this certificate is punishable by a fine of not exceeding \$1,000, or imprisonment not exceeding 3 years, or both.

This certificate may be transferred in accordance with FAR 21.47.

FAA FORM 8110-2(110-68)



Department of Transport

Supplemental Type Certificate

This approval is issued to:

Onboard Systems
11212 NW St. Helens Road
Portland, OREGON 97231
UNITED STATES OF AMERICA

Number: SH01-52

Issue No.: 1

Approval Date: September 11, 2001

Issue Date: September 11, 2001

Responsible Office: PACIFIC

Aircraft/Engine Type or Model: Bell 206L 1, 206L 3, 206L 4, and 407

Canadian Type Certificate or Equivalent: H-92

Description of Type Design Change: Installation of Onboard systems Cargo Hook Suspension System per FAA STC SR00724SE

Installation/Operating Data,
Required Equipment and Limitations:

Installation of Onboard Systems Model 200-249-00 (without load weight) or 200-250-00 (with load weight) cargo hook suspension system is to be carried out in accordance with FAA approved Onboard Systems Owner's Manual No. 120-085-00, dated April 1, 1999. This cargo hook suspension system is to be fabricated in accordance with FAA approved Onboard Systems Master Drawing List No. 155-049-00, dated May 7, 1999. Inspect this cargo hook suspension system in accordance with Section 5 of Onboard Systems Owner's Manual No. 120-085-00, dated April 1, 1999.

Approval of this change in type design applies to Bell model rotorcraft listed above, which were previously equipped with an FAA approved installation of Bell Auxiliary Equipment Kit - Cargo Hook Provisions P/N 206-706-341-7, -9, -103, -111, or -113. Modified rotorcraft must be operated in accordance with an FAA approved copy of Onboard Rotorcraft Flight Manual Supplement No. 120-085-00, dated August 4, 1999.

Basis of Certification as defined in the applicable Type Certificate Data Sheets.

-- End --



Conditions: This approval is only applicable to the type/model of aeronautical product specified therein. Prior to incorporating this modification, the installer shall establish that the interrelationship between this change and any other modification(s) incorporated will not adversely affect the airworthiness of the modified product.

Signature of Henry Wong
Henry Wong
For Minister of Transport

