

**PLEASE CHECK WEB SITE AT WWW.ONBOARDSYSTEMS.COM FOR
THE LATEST REVISION OF THIS MANUAL**

Data Card System

Owner's Manual

C-30 Data Recorder System

And Optional Equipment

Document Number 120-089-00

Revision 6

September 18, 2007



13915 NW 3rd Court Vancouver Washington 98685 USA
Phone: 360-546-3072 Fax: 360-546-3073 Toll Free: 800-275-0883
www.OnboardSystems.com

Copyright © 1999 by Onboard Systems, Inc. Printed in the United States of America. All rights reserved. No part of this publication may be reproduced, stored in a retrieval system, or transmitted, in any form or by any means, electronic, mechanical, photocopying, recording, or otherwise, without prior written permission of Onboard Systems, Inc., 13915 NW 3rd Court, Vancouver Wa 98685. Telephone 360 546-3072. Fax 360 546-3073.

The information contained in this manual is offered as is, without warranty of any kind, express or implied. ONBOARD SYSTEMS DISCLAIMS SPECIFICALLY THE IMPLIED WARRANTIES OF MERCHANTABILITY AND FITNESS FOR A PARTICULAR PURPOSE. In no event shall Onboard Systems be liable for indirect, special, incidental or consequential damages resulting from the use of the information, even if Onboard Systems has been advised of the possibility of such damages.

If acquired subject to FAR or DFARS, the following shall apply as applicable:

- Unpublished — rights reserved under the copyright laws of the United States.
- RESTRICTED RIGHTS LEGEND
Use, duplication, or disclosure by the Government is subject to restrictions as set forth in subparagraph (c) (1) (ii) of the Rights in Technical Data and Computer Software clause at DFARS 52.227-7013. Onboard Systems, Inc., 13915 NW 3rd Court, Vancouver Wa 98685.

IBM is a registered trademark of International Business Machines.

RECORD OF REVISIONS

<i>Revision</i>	<i>Date</i>	<i>Page(s)</i>	<i>Reason for Revision</i>
1	6/17/02	3-41	Changed Indicator symbols on top 3 boxes. Original symbols taken from C-20 manual, C-30 is different.
2	9/17/02	Title, A-5	Factory address change.
3	04/26/06	1-9, 2-10, T.O.C.	Updated error codes, changed page numbering, add battery replacement section for card reader.
4	11/14/06	4-5	Added instructions for when printing in KG units.
5	08/07/07	7-2, &7 -3	Added instructions to adjust contrast from blank screen.
6	09/18/07	TOC, 2-1 to 2-5, 2-7 to 2-9, 3-21 to 3-24, 3-34, 4-3 to 4-6, 6-5, 6-12 & 7-1	Added explanation of warnings cautions and notes to introduction section. Updated warnings, cautions and notes through out.

Register Your Products for Automatic Notifications

Onboard Systems offers a free notification service via fax or email for product alerts and documentation updates. By registering your Onboard Systems products at our website, we will be able to contact you if a service bulletin is issued, or if the documentation is updated.

You can choose to receive notices on an immediate, weekly, or monthly schedule via fax, email or both methods. There is no charge for this service. Please visit our website at www.onboardsystems.com/notify.php to get started.

This page intentionally left blank.

Contents

***Section 1* Introduction**

- Warnings, Cautions and Notes, 1-1
- System Overview, 1-2
- Future Expansion of the C-30, 1-5
- Bill of Materials, 1-6
- Components, 1-7
 - C-30 Data Recorder, 1-7
 - C-23 Printer, 1-8
 - Data Card, 1-8
 - Data Card Reader, 1-9
 - Software, 1-9
 - System Requirements, 1-10
 - Serial Cable, 1-10

***Section 2* Installing the Data Card System and Optional Equipment**

- Unpacking Inspection, 2-1
- Installing the Data Recorder, 2-2
- Installing User-Supplied Switches, 2-3
 - Installing the Flight-Time Switch, 2-3
 - Installing a Capture Switch, 2-4
- Making Electrical Connections, 2-5
- Installing the Data Card Reader, 2-5
- Installing the PC Software, 2-7
 - IBM PC and Compatibles, 2-7
- Uninstalling the PC Software, 2-8
 - IBM PC and Compatibles, 2-8
- Upgrading the PC Software, 2-9

***Section 3* Operating the Data Recorder**

- About the Front Panel, 3-2
- Turning on the Data Recorder, 3-3
- Using the Menus, 3-4
 - Accessing Menus with the System Menu, 3-5
 - Scrolling Through a Menu, 3-6
 - Changing a Menu Selection, 3-6
 - Exiting a Menu, 3-6
- Entering Setup Data, 3-7

Section 3, cont. Operating the Data Recorder

- Entering Pilot Identifier, 3-9
- Entering Aircraft Identifier, 3-10
- Setting Recording Mode, 3-11
- Setting Minimum Lift Load, 3-12
- Setting Minimum Lift Time, 3-13
- Setting the Average Time, 3-14
- Setting the Average Start Time, 3-15
- Entering the Date, 3-16
- Entering the Time, 3-17
- Specifying Flight-Time Switch Polarity, 3-18
- Setting the Units Legend, 3-19
- Setting Dampening, 3-20
- Managing the Customer List, 3-21
- Managing the Location List, 3-23
- Entering Company Data, 3-25
- Using the Utilities Menu, 3-27
 - Viewing the Software Version Number, 3-28
 - Adjusting the Display Contrast, 3-28
 - Adjusting the Back-Lighting, 3-29
 - Erasing Memory, 3-29
- Using the Options Menu, 3-30
 - Internal Accelerometer, 3-31
 - Status, 3-32
- Using the Run Screen, 3-33
 - During a Lift, 3-33
 - Viewing Customer Totals, 3-34
- How Lifts are Recorded, 3-35
 - Determining When a Lift is Recorded, 3-35
 - Manual Method, 3-35
 - Automatic Method, 3-35
 - Determining the Weight of a Lift, 3-35
 - Manual Method, 3-35
 - Automatic Method, 3-36
- Improving the Accuracy of Lifts Recorded Automatically, 3-36
- Recording a Flight and Lift, 3-39
- C-30 Internal Battery, 3-42
- Attention Messages, 3-42
 - System Conditions, 3-42

***Section 4* Operating the Printer**

Turning on the Printer, 4-2
Printing a Self-Test, 4-2
Installing the Paper, 4-3
Installing the Cartridge Ribbon, 4-3
Clearing a Paper Jam, 4-4
Printing a Report, 4-5
Printing in KG Units, 4-6
Reading a Report, 4-6

***Section 5* Using the Data Card**

Copying the System Memory with the Data Card, 5-2
Memory Capacity of the Data Card, 5-3

***Section 6* Using the Optional Software**

Opening WinHook, 6-1
Retrieving Data, 6-2
Downloading Data from a Data Card, 6-3
Downloading Data from C-30 Serial Port, 6-5
Opening a File, 6-6
Saving Data, 6-7
Exporting Data, 6-8
Printing a Report, 6-9
Reading a Report, 6-11
Editing the Report Header, 6-12
Options, 6-13

***Section 7* Maintaining the System**

Data Recorder Care, 7-1
Cable and Connector Maintenance, 7-1
Troubleshooting, 7-2

***Section 8* Installation Authorization**

FAA Letter of Authorization, 8-1

Appendix

- Specifications, A-2
 - Physical Specifications, A-2
 - Electrical Specifications, A-2
- Ordering Information, A-4
- Limited Warranty, A-5
- Return Instructions, A-6

Figures

- 1-1 The data card system's aircraft-based components, 1-3
- 1-2 The data card system's office-based components, 1-4
- 1-3 The laptop attached to the C-30, 1-4
- 1-4 Potential features of the C-30, 1-5
- 1-5 C-30 Data Recorder, 1-7
- 1-6 C-23 Printer, 1-8
- 1-7 Data card, 1-8
- 1-8 Data card reader, 1-9
- 1-9 Serial Cable, 1-10
- 2-1 Installing the data recorder, 2-2
- 2-2 Flight-time switch wiring guide, 2-4
- 2-3 Capture switch wiring guide, 2-5
- 2-4 The data card installation, 2-6
- 2-5 Data Card Reader with an A-B Switch, 2-6
- 3-1 Data recorder front panel, 3-2
- 3-2 System Menu loop, 3-5
- 3-3 Setup Data menu loop, 3-8
- 3-4 Company Data menu loop, 3-26
- 3-5 Utilities menu loop, 3-27
- 3-6 Options menu loop, 3-30
- 3-7 Internal Accelerometer menu loop, 3-31
- 3-8 Run screen with lift information, 3-33
- 3-9 Run screen with customer totals, 3-34
- 3-10 Load Profile, 3-36
- 3-11 Exaggerated Load Profile, 3-37
- 3-12 Typical Automatic Setup, 3-37
- 3-13 Increasing Average Start Time, 3-38
- 3-14 Recording a lift, 3-41
- 4-1 An example full report, 4-7
- 4-2 An example summary for Customer 1, 4-8
- 5-1 Inserting the data card, 5-2
- 6-1 Typical customer report, 6-10

Tables

- 4-1 Report types and their screen selections, 4-5
- 4-2 Sections printed on a report or a summary, 4-8
- A-1 Physical specifications, A-2
- A-2 Data recorder electrical specifications, A-2
- A-3 Data Recorder Pin Out, A-2
- A-4 C-39 Indicator Pin Out, A-3
- A-5 Load Cell Pin Out, A-3
- A-6 Ordering information, A-4

This page intentionally left blank.

Section 1

Introduction

This manual describes installation and operation of the ONBOARD SYSTEMS Data Card System and optional equipment.

NOTE

Please read the procedures and other information given in this manual before attempting to install or operate this system.

Warnings, Cautions & Notes

The following definitions apply to Warnings, Cautions & Notes used in this manual.



WARNING

Means that if this information is not observed, serious injury, death or immediate loss of flight safety could occur



CAUTION

Means that there is a risk of injury or degradation in performance of equipment if this information is not observed.

NOTE

Draws the reader's attention to information which may not be directly related to safety, but which is important or unusual.

System Overview

The ONBOARD SYSTEMS Data Card System is a hook-load data recording accessory system designed to complement ONBOARD SYSTEMS E Series hook-load measuring systems. The data logging or recording system frees the pilot and ground personnel from the recording task by logging the hook-load weight, date and time, and duration for each lift. Summary totals and averages are also calculated. The recorded information can be printed directly or transferred to your computer for printing or further processing.

The system integrates hook-load measurement with computerized data recording. While the measuring system measures the weight of lifts during a job, the data recorder displays flight and lift information, and stores a comprehensive record of this data. The data can be retrieved from the data recorder by inserting a data card or connecting a laptop to the data recorder serial port. Reports can be printed directly from the data recorder using the C-23 printer.

The data card system complements your existing weighing system, providing an additional source of lift data that is rigorously collected throughout the job. However, you should not rely on the accuracy of the data unless you are confident that the system is correctly installed and that the pilot is using the system correctly.

A basic system includes a data recorder and two wires to install the flight time switch and the capture switch and an owner's manual. Optional equipment includes one or more data cards, a data card reader, a cockpit printer, computer software and a serial cable.

Figure 1-1 shows the data card system components together with optional equipment and load measuring equipment that are used in the aircraft. Figure 1-2 shows the optional components that are installed in the office. Figure 1-3 shows a laptop attached to the C-30 through the serial cable. The data card or the laptop is the link between the aircraft and the office. It carries data collected by the data recorder to the data card reader and the computer.

Figure 1-1 The data card system's aircraft-based components

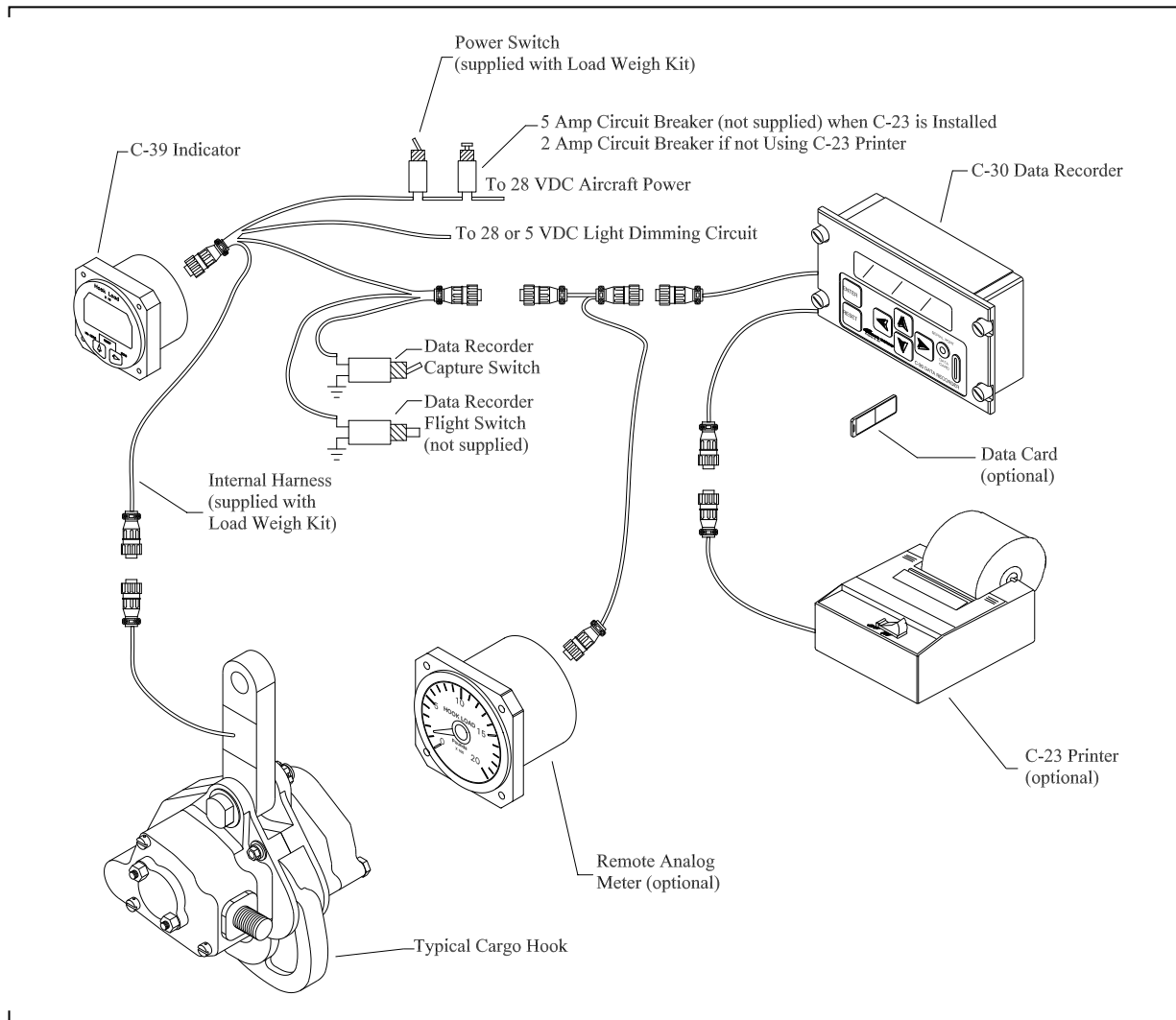

Figure 1-2 The data card system's office-based components

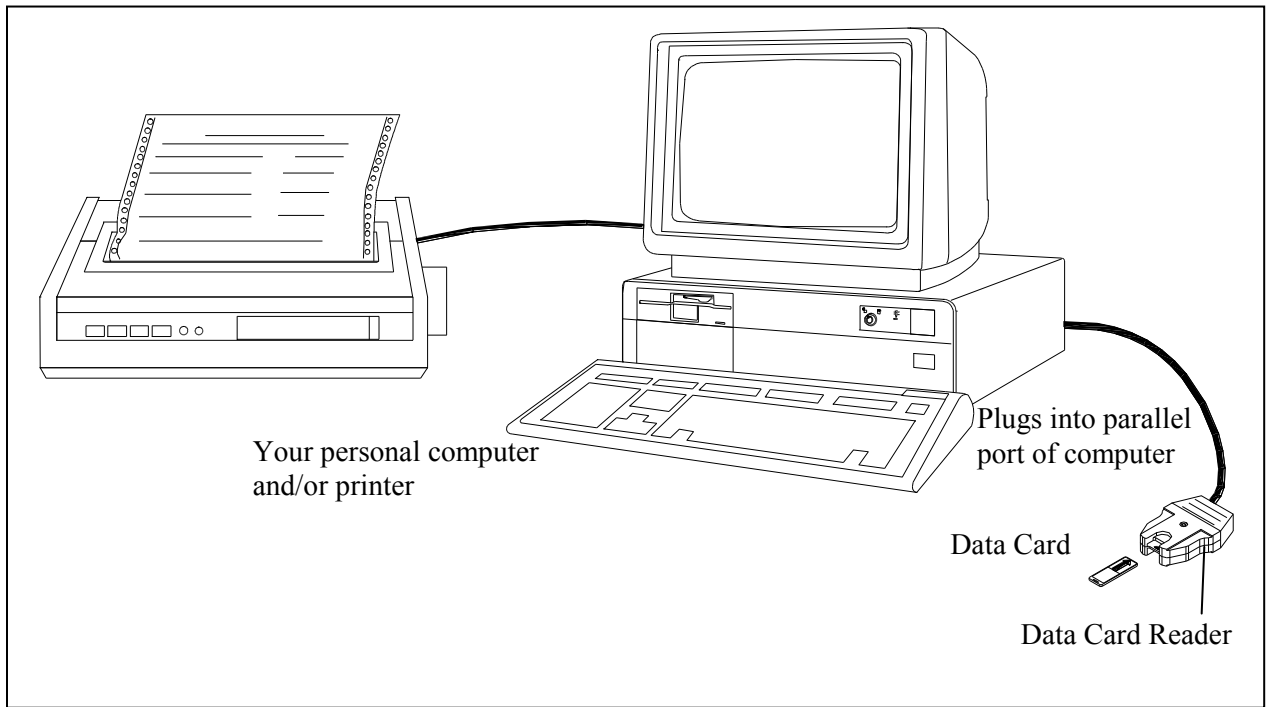
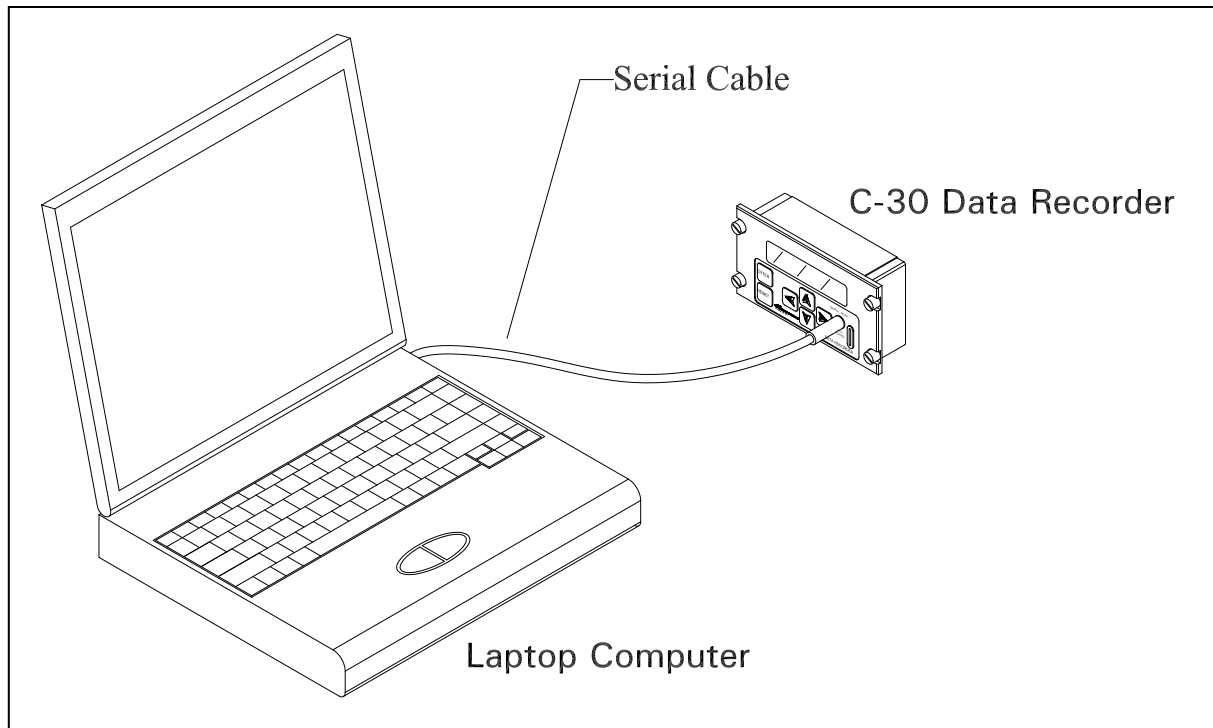

Figure 1-3 The laptop attached to the C-30



Future Expansion of the C-30

The C-30 Data Recorder is a powerful cockpit computer with significant expansion possibilities. The C-30 is equipped with a CAN Buss capable of communicating with up to 256 external devices. These devices could be external accelerometers, kneepads, engine sensors, GPS etc. Our expansion efforts are customer driven, please contact our sales department for details.

Figure 1-4 Potential features of the C-30

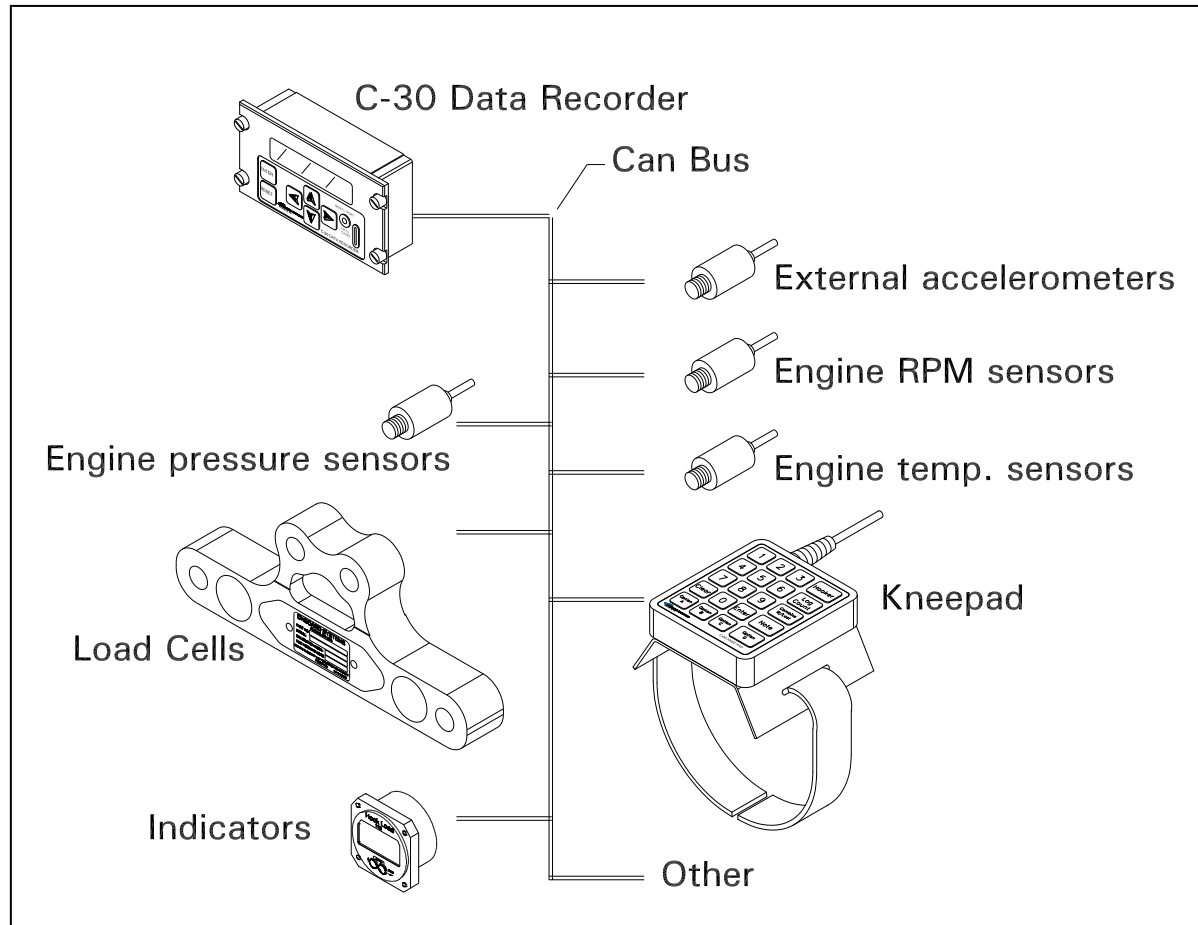

Bill of Materials

The following items are included with each Data Recording System P/N 200-257-00. If shortages are found contact the distributor from whom the system was purchased.

<u>P/N</u>	<u>DESCRIPTION</u>	<u>QUANTITY</u>
120-089-00	Owner's Manual	1
210-189-00	C-30 Data Recorder	1
270-019-00	Capture Switch Wire	1
270-022-00	Flight Time Switch Wire	1

The following items are optional and are ordered separately.

<u>P/N</u>	<u>DESCRIPTION</u>
475-021-00	Data Card
210-195-00	Data Card Reader
210-100-00	C-23 Printer
100-050-00	C-30 PC Software
270-099-00	Serial Cable

Components

The following paragraphs describe the major components of the data card system and optional equipment. These are the C-30 Data Recorder, the C-23 Printer, the Data Card, the Data Card Reader, interface software and the serial cable.

C-30 Data Recorder

The C-30 Data Recorder is a programmable microprocessor-based device that attaches to an existing connector on the Onboard Systems E Series hook-load measuring system in the cockpit. It reads data entered by the pilot and monitors the data from the weighing system. A two-line by 20-character alphanumeric LCD display shows duration information for the current flight, and duration and weight data for the current load in pounds or kilograms. Six front panel keys let the pilot enter identifying information and change display characteristics. The display shows current flight and lift data and can be used as a copilot remote indicator. Figure 1-5 shows the C-30 Data Recorder.

Figure 1-5 C-30 Data Recorder

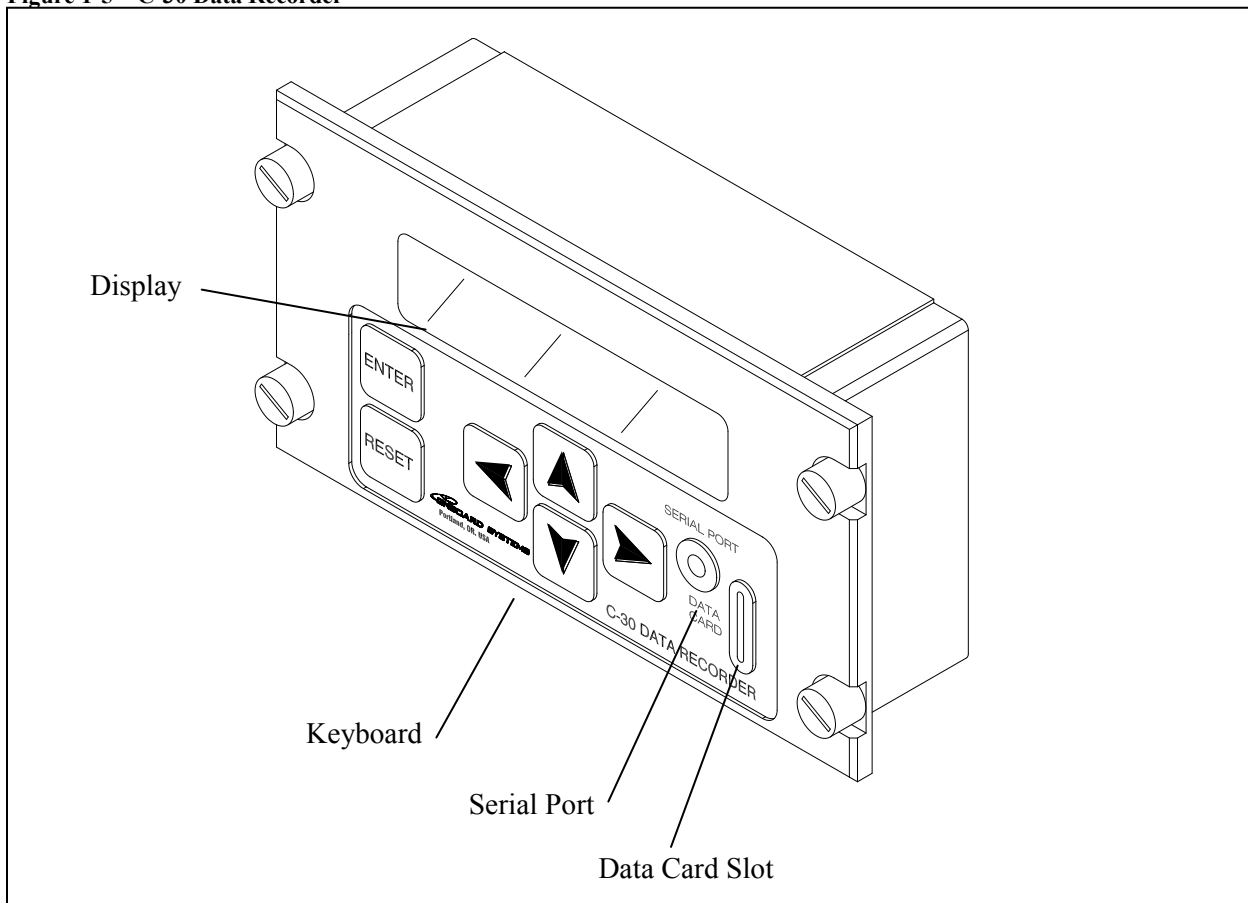

C-23 Printer

The C-23 Printer is a compact, easy to use, 24-characters per line printer. It is connected directly to the data recorder, making it possible to print reports in the aircraft. Figure 1-6 shows the C-23 Printer. **The printer is not intended to be mounted in the aircraft.**

Figure 1-6 C-23 Printer

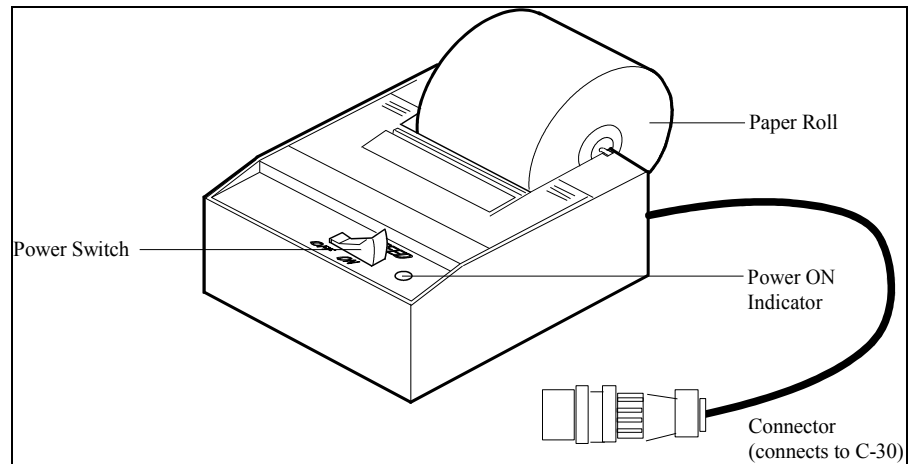

Data Card

The Data Card is a compact memory device used to retrieve the recorded data from the data recorder and transport it to the PC.

The data card can be erased at any time using the data recorder and reused. The memory of the data card is 1MB (Megabytes). The card stores approximately 60,000 entries. Refer to the section, *Using the Data Card*, for more information about the data card.

Figure 1-7 Data card

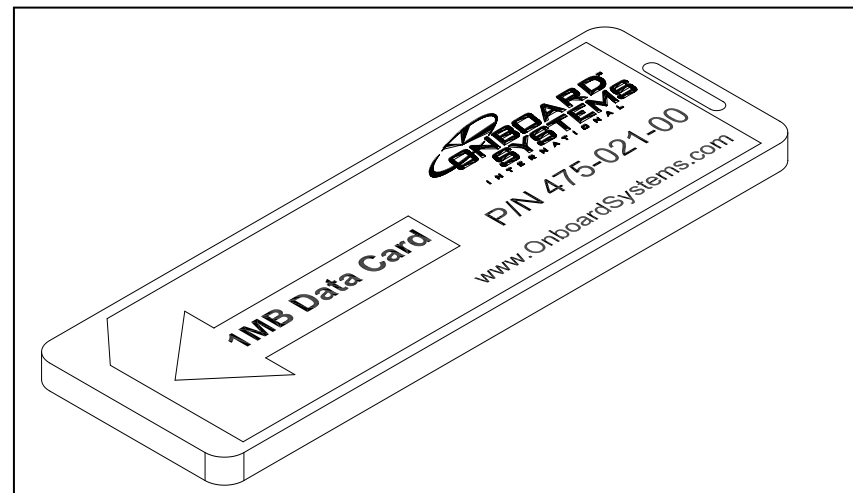

Data Card Reader

The Data Card Reader is a compact device used to receive the Data Card and transfer the stored data to the PC. The card reader attaches to a PC parallel port. To retrieve lift data from the Data Card, you plug the card into the Data Card Reader and use the optional PC software to display, print, and save the information. Figure 1-8 shows the data card reader. A single data card reader can support many data card systems installed in separate aircraft.

Figure 1-8 Data card reader

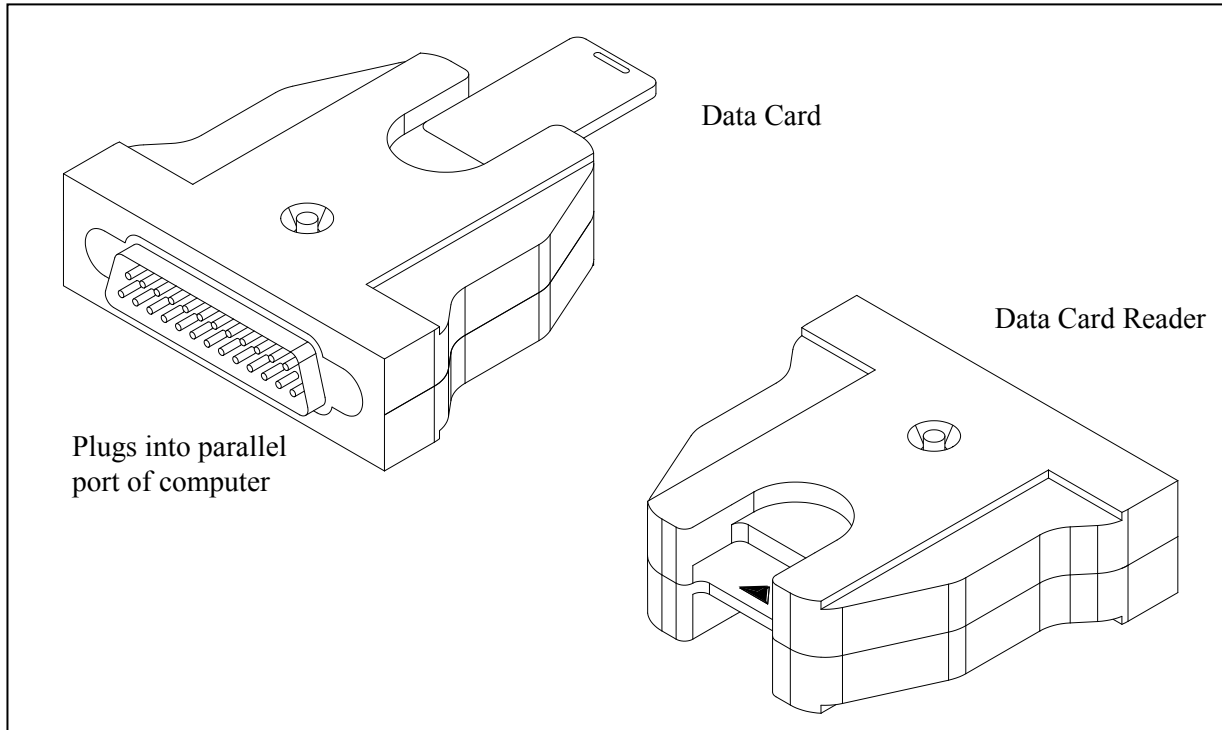

Replacing your Data Card Reader's batteries

With the label side of the data card reader facing up, gently pry the two casing halves apart using a flat head screwdriver. Lift top casing straight up taking care not to catch the casing on the internal pins.

Remove the old batteries. The new batteries should be set on the board as indicated on the board. The indicated side should contact the board so that plus meets plus and negative meets negative.

Replace top casing making sure the interior pins are aligned and press to close.

Software

Optional PC software, WinHook, for your IBM PC-compatible computer prompts the user to display, print, export and save the collected data.

System Requirements

The WinHook program is contained on two 3-1/4" diskettes. System requirements are as follows:

- Windows 95 or 98, (NT can be used with the serial port only)
- 486 PC's and above
- 8 MB RAM minimum
- 5 MB free hard disk space
- 3-1/4" floppy disk drive

Serial Cable

The Serial Cable is used to connect a laptop computer to the C-30. This connection allows the transfer of data from the C-30 to the laptop. The cable is fitted with a DB-9 connector on one end and a plug on the other. Figure 1-9 shows the serial cable.

Figure 1-9 Serial Cable

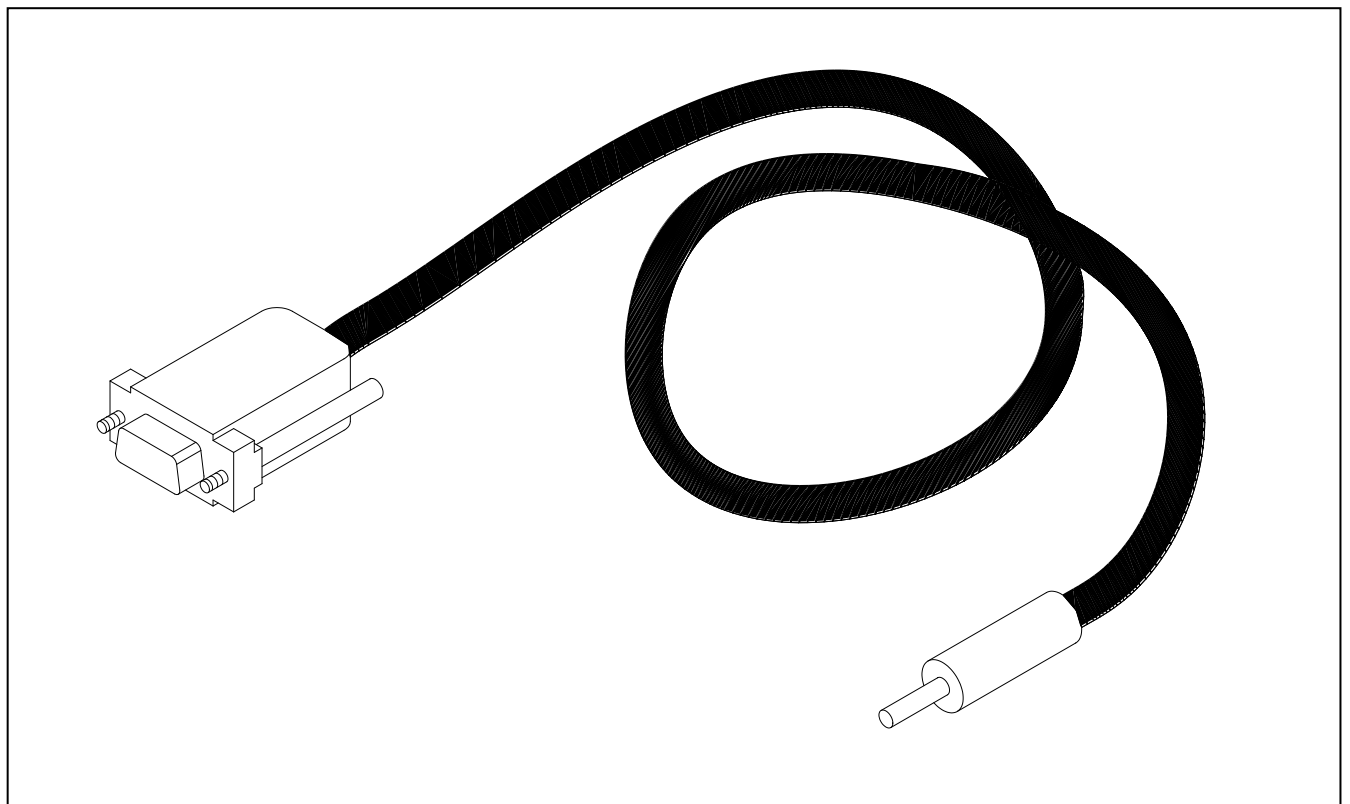

Section 2

Installing the Data Card System and Optional Equipment

This section describes how to install the components of the Data Card System and optional equipment.

Unpacking Inspection

After unpacking the components of your data card system, check each component against the packing list to ensure that you have received the correct items. If you find an error, notify the distributor immediately.

Inspect the components for evidence of mishandling or damage. All parts packaged at the factory were carefully tested, inspected, and packed. If damage is evident, do not proceed with installation. Instead, file a claim with the carrier and notify the distributor from whom the components were purchased. Refer to the *Appendix* for more information about returning a system component.

Installing the Data Recorder

Follow these steps to install the data recorder in the aircraft cockpit. Refer to Figure 2-1, and to Figure 1-1 earlier in this manual.

NOTE

When the optional C-23 printer is used, the system circuit breaker must be rated at 5 amp.

1. Select an installation location within easy reach of the pilot that allows comfortable viewing during flight.
2. Secure the data recorder to the Dzus rails or another suitable means of installation. The data recorder must be solidly mounted parallel with the ground, within 5°, and facing forward as illustrated in Figure 2-1.



The Data Recorder contains sensitive accelerometers. It is essential that the C-30 be installed parallel to the ground within 5° in the right and left orientation as illustrated in Figure 2-1.

3. The data recorder has two connectors. The connectors are configured differently to prevent mismatching them. Connect one to the load weigh system's internal harness and the other to the optional C-23 Printer. Refer to Figure 1-1 earlier in this manual.

Figure 2-1 Installing the data recorder

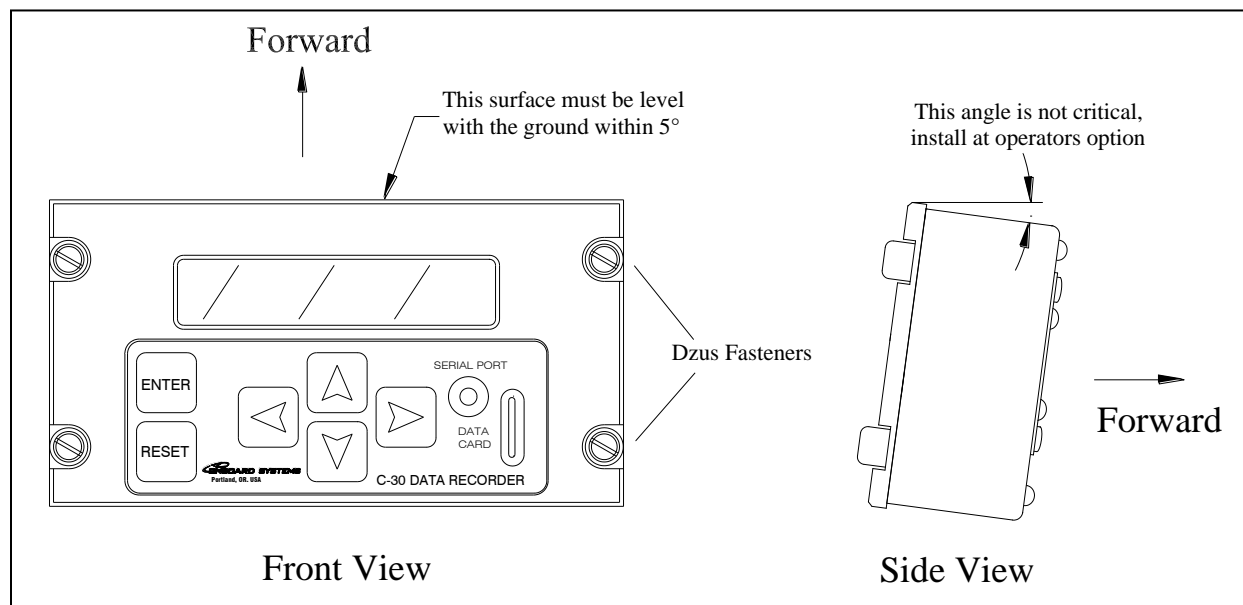

Installing User-Supplied Switches

The flight-time and load-capture switches are used to record the flight and to give the pilot control over when a load is recorded. The switches are user supplied.

Installing the Flight-Time Switch

Installation of the flight-time switch is required. The switch allows the data recorder to register the beginning and end of each flight. You can install the flight-time switch at any available switch, either normally open or normally closed, on the helicopter controls or in another location that is convenient to the pilot. For a typical installation you would install the flight-time switch on the collective so that when the pilot pulls up on the collective, the switch opens (or closes) and flight time begins counting. A six-foot length of red-coated 24-gauge wire is supplied for use in installing the flight-time switch. The wire is equipped with a pin connector on one end.

The flight-time switch can be wired several ways. Use this procedure and Figure 2-2 as a guide. Refer back to Figure 1-1 for an overview diagram of the switch location in the system.

1. Disassemble the data recorder connector located in the load weigh internal harness by unscrewing it. Notice that each pin socket is labeled with a number.
2. Insert the pin connector of the supplied wire into Pin Socket #4.

NOTE

Be sure the pin socket is the correct one. Once inserted, the pin cannot be removed without the use of an extraction tool.

3. Reassemble the data recorder connector.
4. Cut the free end of the wire to the desired length.
5. Connect the wire to the selected switch.
6. Connect the other side of the switch to a good airframe ground.
7. Using the data recorder's Setup Data menu, set the flight switch menu item to the appropriate polarity setting based on flight-time switch wiring: Select HIGH if the data recorder is connected to airframe ground during flight, select LOW if the data recorder is disconnected from airframe ground during flight.

Figure 2-2 Flight-time switch wiring guide

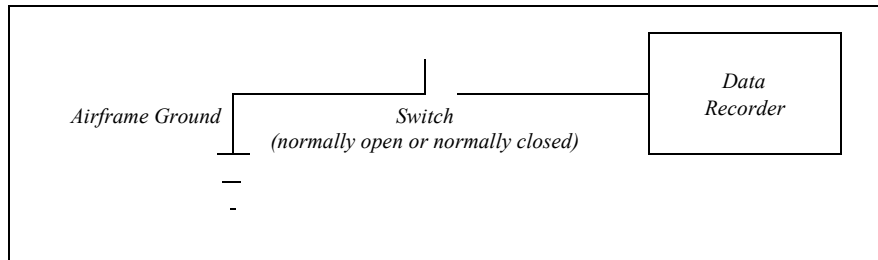

Installing a Capture Switch

A capture switch gives the data recorder the capability of registering the weight of a load at the moment the pilot presses the switch. A capture switch is not required; the data recorder automatically takes load readings throughout each lift, discards outlying values, and records an average weight for the lift. Lifts measured automatically and lifts captured with a capture switch can be intermingled. The display and the printouts indicate which method of recording was used.

If a capture switch is desired, you can use any available normally open switch on the helicopter controls or any other normally open switch. The switch location should be convenient for the pilot to use. A six-foot length of purple-coated 24-gauge wire is supplied for use in installing a capture switch. The wire is equipped with a pin connector on one end.

To install the capture switch, use this procedure and Figure 2-3 as a guide. Refer back to Figure 1-1 for an overview diagram of the switch location in the system.

1. Disassemble the data recorder connector located in the load weigh internal harness by unscrewing it. Notice that each pin socket is labeled with a number.
2. Insert the pin connector of the supplied wire into Pin Socket #2.

NOTE

Be sure the pin socket is the correct one. Once inserted, the pin cannot be removed without the use of an extraction tool.

3. Reassemble the data recorder connector.
4. Cut the free end of the wire to the desired length.
5. Connect the wire to the selected switch.
6. Connect the other side of the switch to a good aircraft ground source.

Figure 2-3 Capture switch wiring guide

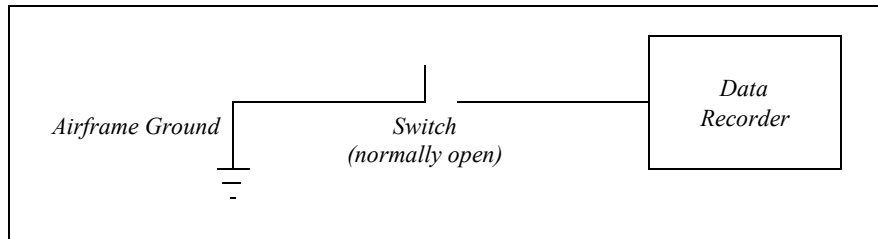

Making Electrical Connections

To connect the data recorder, plug the connector on the data recorder into the socket provided on the internal harness of the load weighing system. Refer back to Figure 1-1 for an overview diagram.

Installing the Data Card Reader

Follow this procedure to install the Data Card Reader to a personal computer. Refer back to Figure 1-2 and Figure 2-4 for an overview diagram.

NOTE

The card reader is connected to a personal computer (PC) parallel port. If a printer is connected to the parallel port it is recommended that the card reader be attached to a second parallel port. Optionally, the use of an A-B Switch box could be used so that a printer and the card reader share a single port. A-B Switch boxes are widely available from computer supply houses. The switch should be equipped with DB-25 connectors and all 25 pins must be switched. An A-B Switch Box is not supplied with the system.

The card reader can be connected directly to the port or for convenience a standard parallel cable can be used to locate the card reader in a more convenient location. A parallel cable is not supplied with the system.

1. Ensure that the power is off to your computer.
2. Connect the data card reader to an available parallel port or A-B switch.
3. Turn on your computer.

Figure 2-4 The data card installation

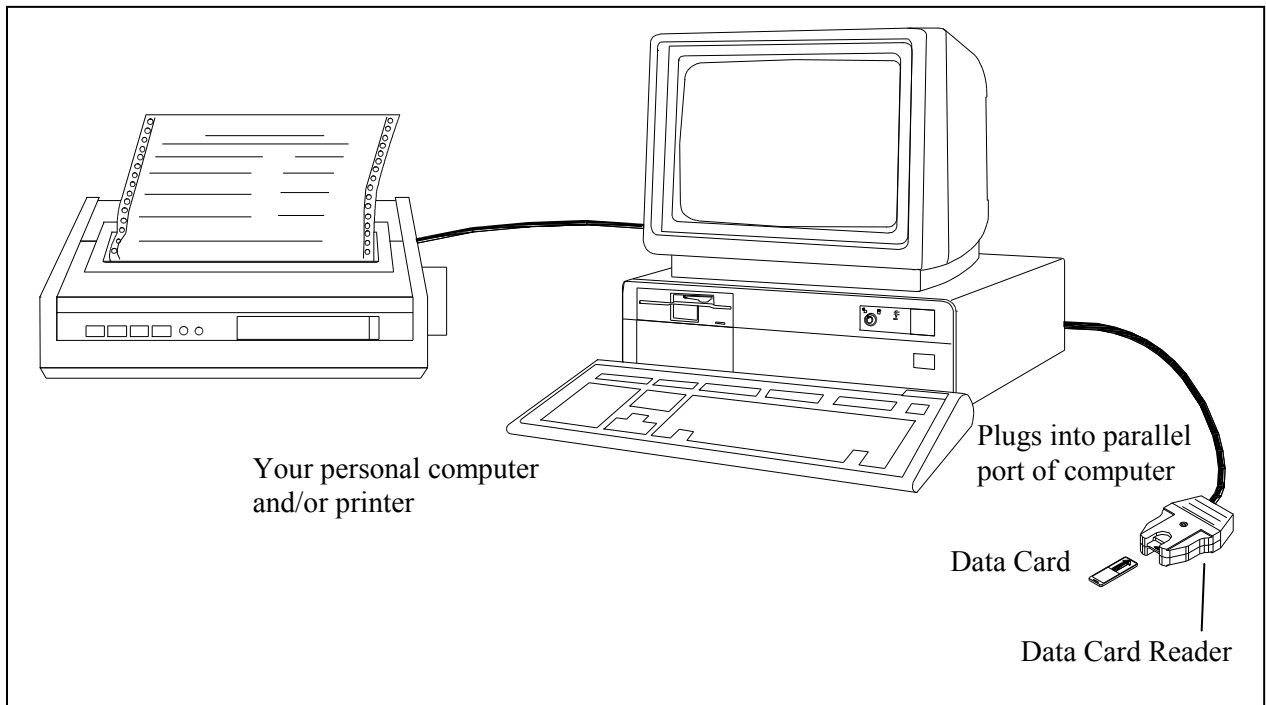
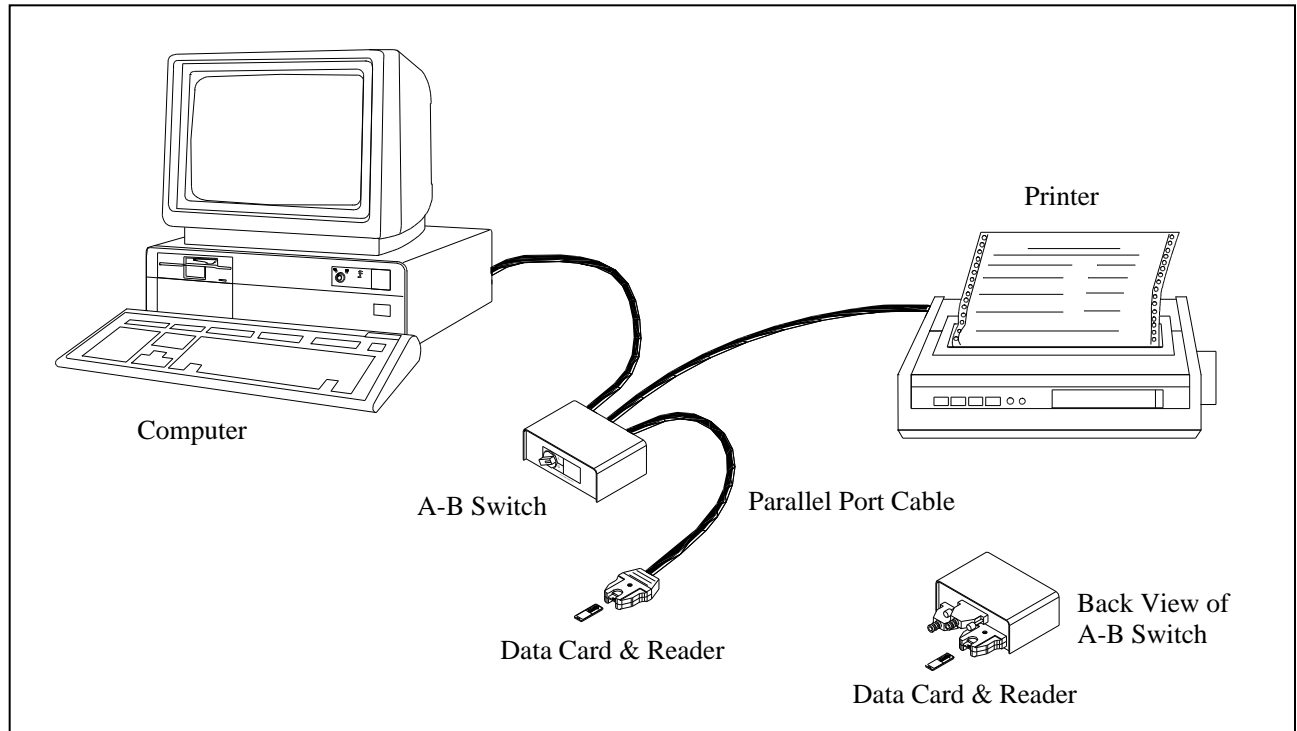

Figure 2-5 Data Card Reader with an A-B Switch



Installing the PC Software

The PC software allows you to display, print, save and export the collected data.

IBM PC and Compatibles

The *WinHook* program is contained on two 3-1/4" diskettes or on one CD-ROM. To install WinHook follow these steps.

1. Insert Disk #1 into your floppy drive or insert CD-ROM into CD Drive. Use Windows Explorer to click on the file Setup.exe.
2. Follow the instructions on the screen.

NOTE

Users who are running earlier versions of Windows 95 may see a box stating that some system components need updated before the WinHook installation can be completed. When asked if it is okay to update the system, click yes and then wait for the system to reboot. If the installation window does not automatically appear, begin these instructions from step 1.

Uninstalling the PC Software

Uninstall WinHook prior to installing a new version or when you would like to remove the program from your computer.

IBM PC and Compatibles

To uninstall WinHook, follow these steps.

1. From the Start menu, click Settings and then click on Control Panel.
2. Double click on Add/Remove Programs.
3. Scroll down until you locate WinHook and double click on it.
4. Click yes to confirm the removal of the program.

NOTE

When WinHook is uninstalled, you may receive an error message that states the system was unable to remove all WinHook components. This is because WinHook creates a configuration file called "Onboard.ini" in the WinHook directory and the uninstaller program does not remove this file. It will not hurt to leave this file on the system.

Even though the WinHook program has been uninstalled, the WinHook directory will still remain on your system since that is the default location for data files (files with .onb extension). You can delete the WinHook directory but keep in mind that if the WinHook directory is deleted, all files contained in that directory will also be deleted.

Upgrading the PC Software

When upgrading the WinHook program, first uninstall the old version by following the steps in *Uninstalling the PC Software*. Once the old version has been removed, follow the steps in *Installing the PC Software* to install the new version.

NOTE

Failure to remove the old version of WinHook before installing a new version does not cause critical problems, but it will result in duplicate Windows Registry entries, making it appear to Windows9x as though multiple copies of WinHook are installed, when in fact there is only one copy installed.

This page intentionally left blank.

Section 3

Operating the Data Recorder

This section describes operation of the C-30 Data Recorder. Here are the topics in this section.

- *About the Front Panel* describes the keys, switches, and display of the front panel.
- *Turning on the Data Recorder* describes how to power up the data recorder.
- *Using the Menus* describes the System Menu and gives general procedures for operating and accessing its submenus.
- *Entering Setup Data* gives detailed procedures and information about the values that can be entered using the Setup Data menu.
- *Managing the Customer List* describes the procedure for entering up to 10 different customers on the Manage Customer List menu.
- *Managing the Location List* describes the procedure for entering up to 10 different locations on the Manage Location List menu.
- *Entering Company Data* describes the procedure for entering information on the Company Data menu for inclusion in a report header.
- *Using the Utilities Menu* describes the screens and procedures available using the Utilities menu.
- *Setting the Display* describes how to set the display contrast and back-lighting to accommodate current lighting conditions and the position of the data recorder.
- *Using the Options Menu* describes the screens and procedures available using the Options menu.
- *Using the Run Screen* shows the primary screen used during flight operations and describes its displays.
- *Recording a Lift* describes the steps to follow when recording a lift.
- *Attention Messages* describes messages that can appear on the front panel display under certain conditions, which require pilot attention.

About the Front Panel

The front panel of the data recorder includes the following features, as shown in Figure 3-1.

- The 2-line by 20-character *liquid crystal display* (LCD) shows lift data, menu settings, and other information of interest to the pilot.
- The *ENTER* key is used to enter new information, select menu choices, and change menu settings.
- The *RESET* key is used to reset data settings.
- The *Up, Down, Left, and Right arrow keys* are used to scroll through the menus and change menu settings.

Figure 3-1 Data recorder front panel

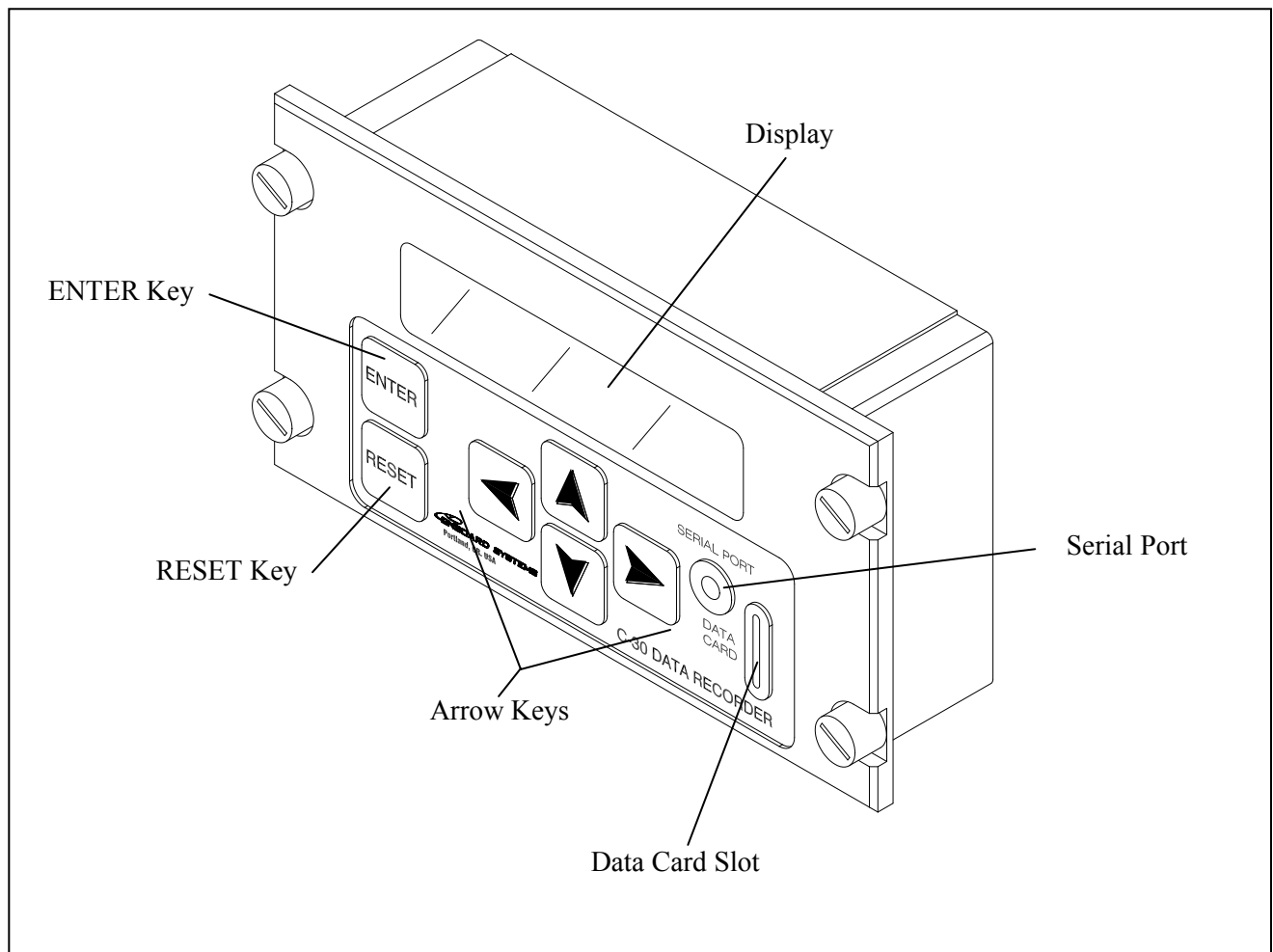

Turning on the Data Recorder

Engage the Data Recorder circuit breaker to power on the unit. The unit does a self-diagnostic routine and then a screen similar to the following appears on the display for 5 seconds. It displays the version number, date and time.

C30	V1.14
7/06/2000	14:26

A screen similar to the following then appears on the display, this is the system's Run Screen. If, instead, a message appears, refer to *Attention Messages* for more information.

Load:	0	↓	(0)
Flight:	000		00:00:00	

Using the Menus

The functions of the data recorder are grouped into menus that you use to enter and display information.

- The *System Menu* accesses the Setup Data, Customer List, Location List, Company Data, Utilities and Options menus. Once you enter information in these menus, it is retained until you change it.
- The *Setup Data menu* contains job identification and setup data that are determined by the pilot on-site. Once set, most of the entries, such as date, time, pilot and aircraft rarely need to be reset.
- The *Manage Customer List menu* allows you to enter up to ten different customer names. Different information can be recorded for each customer
- The *Manage Location List menu* allows you to enter up to ten different locations. Different information can be recorded for each customer.
- The *Company Data menu* provides six 20-character lines for the entry of your company name and address or other information you want printed as a report header.
- The *Utilities menu* displays the system version number and allows you to erase internal memory and change the display back-lighting and contrast.
- The *Options menu* contains the optional equipment setup information.
- The *Print menu* is accessed by pressing ENTER when the Run screen is displayed. The menu allows you to specify full report or summary format, and to select a particular customer for the report.

The selections that appear on these menus are described in detail later in this section.

The following paragraphs describe how to:

- Use the System Menu to access the Setup Data, Customer List, Location List, Company Data, Utilities and Options menu.
- Scroll through a menu
- Change the value of a menu setting
- Exit a menu and return to the Run screen

For detailed information on a particular menu setting, refer to the description of that setting later in this section.

Accessing Menus with the System Menu

You use the System Menu to access the Setup Data, Customer List, Location List, Company Data, Utilities and Options menus. You can access the System Menu whenever the Run screen is displayed. To access a menu, follow these steps.

1. From the run screen press the Up *and* Down keys simultaneously to enter the System Menu.
2. Use the Up or Down keys to select the desired menu name. Figure 3-2 shows the screens on the System Menu.
3. Press ENTER to access the selected menu.

Figure 3-2 System Menu loop

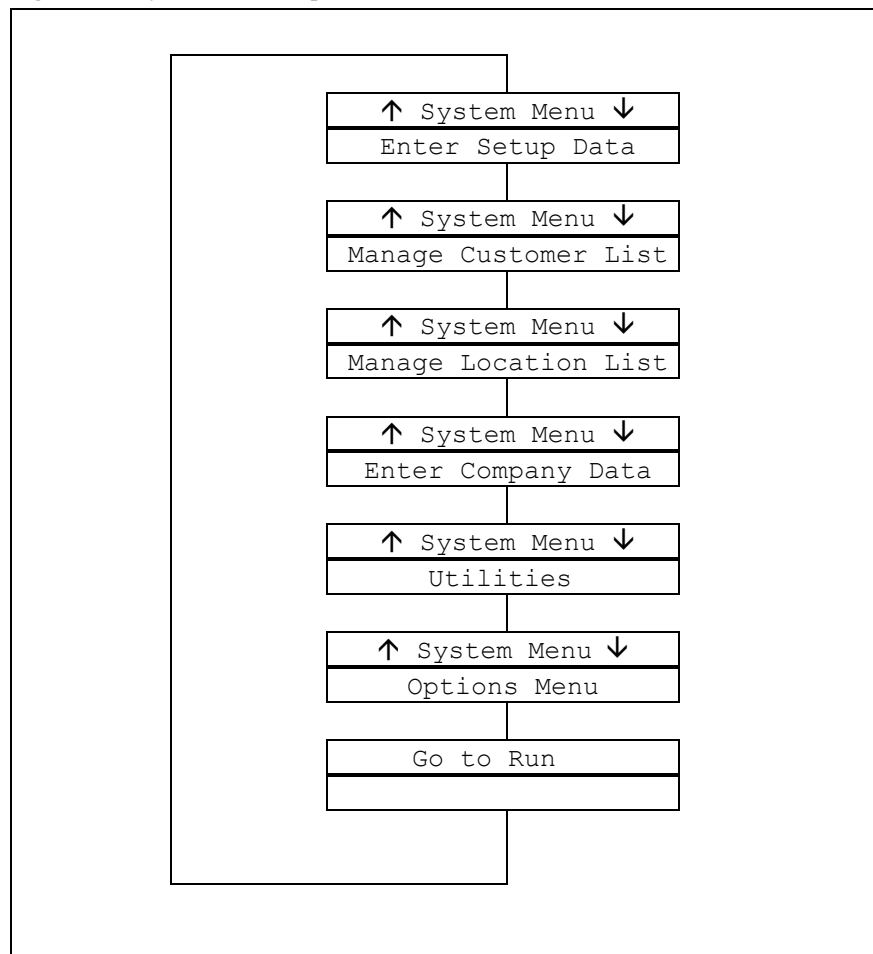

Scrolling Through a Menu

To scroll through the selections on a menu without changing any settings, press either the Up key or the Down key. The selections on each menu are arranged in a continuous loop.

Changing a Menu Selection

To change the current setting of a particular menu selection, follow these steps.

1. Access the desired menu.
2. Use the Up or Down keys to scroll through the menu until you see the desired selection.
3. Press the Right or Left key to access entry mode for the menu selection. A cursor appears below the first character that you can change.
4. Now enter the desired setting. Use the Left or Right keys to position the cursor under the character, number, or setting you want to enter or change. Then use the Up or Down keys to scroll through the choices.
 - For *alphanumeric* entries such as aircraft identifier or company data, the choices are the characters A-Z, 0-9, space, hyphen, slash, apostrophe, and period.
 - For *numeric* entries such as date or time, the choices are 0-9.
 - For entries that are *alternate choices*, such as English and Metric, you toggle between the choices.
 - Angle brackets are used to show the last choice entered.
5. When the setting is displayed correctly, press ENTER to enter the new setting and return to the current menu. The menu selection that follows the selection you just set is displayed.

Exiting a Menu

To exit a menu and return to the Run screen, follow these steps.

1. Press the Up or Down key to scroll through the menu until the following display appears.

Go to Run

2. Press the ENTER key. The Run screen appears.

Entering Setup Data

The Setup Data menu allows you to view and enter setup data and job information that are determined or verified by the pilot on-site. Some values, such as aircraft and pilot identifiers, help identify the job. Some entries, such as time and date, are used by the data recorder to calculate data such as length of lift. Other settings, such as operating mode, minimum lift load, minimum lift time, flight switch polarity, or units setting, are determined by job conditions or the configuration of your aircraft or weighing system.

Setup Data menu entries include these items.

- Pilot identifier
- Aircraft identifier
- Operating mode, either automatic or manual recording
- Minimum lift load, used during automatic recording
- Minimum lift time, used during automatic recording
- Average time
- Average Start Time
- Current date
- Current time
- Flight switch polarity
- Units legend, either LB or KG
- Dampening

Descriptions of each menu selection appear on the following pages.

To access the Setup Data menu from the Run screen, follow these steps.

1. Press the Up *and* Down keys simultaneously to access the System Menu.
2. Use the Up or Down keys to display the "Enter Setup Data" selection.

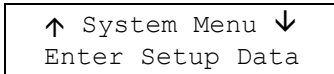

3. Press ENTER. You can now scroll through the selections in the Setup Data menu loop shown in Figure 3-3.

Figure 3-3 Setup Data menu loop

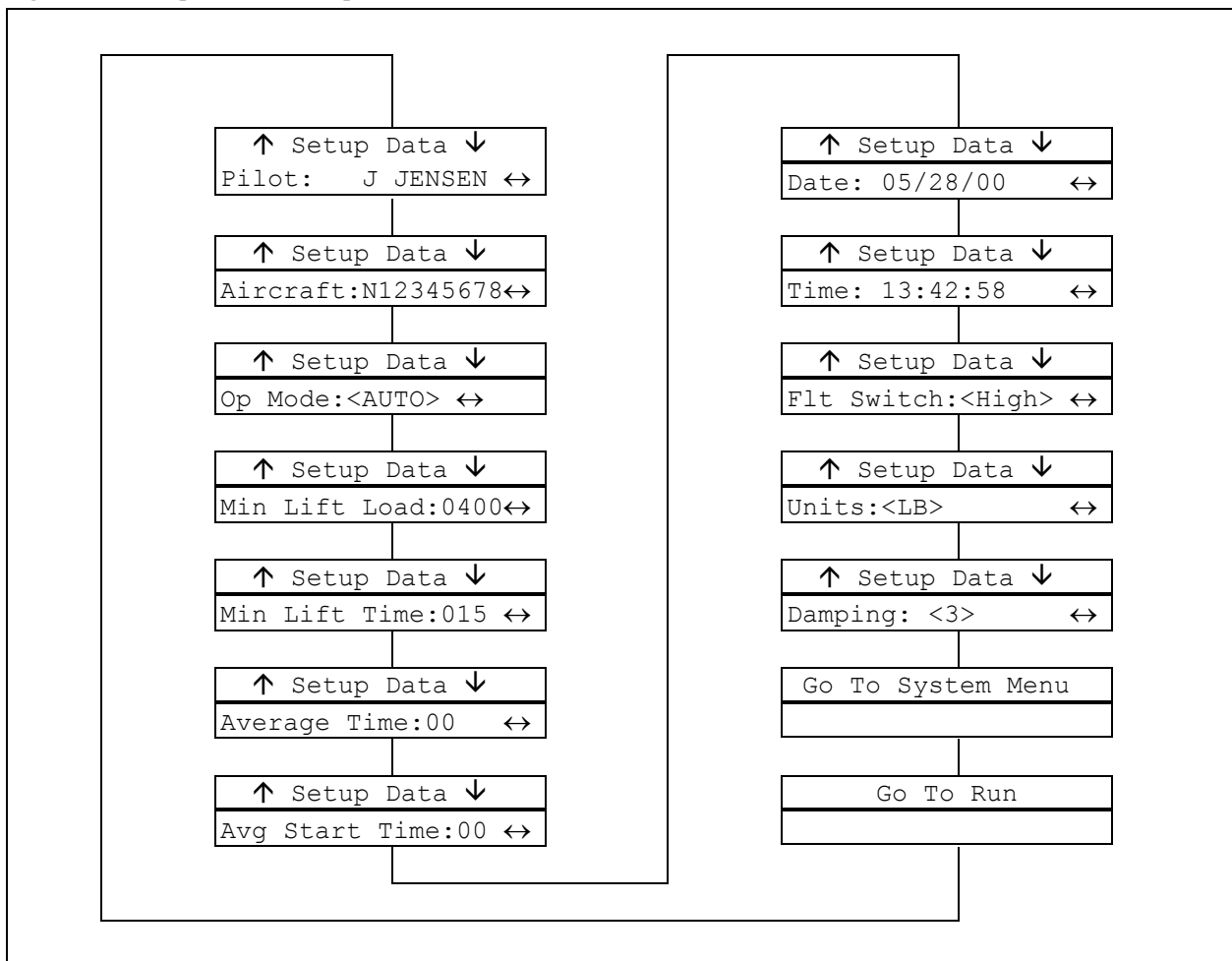

Entering Pilot Identifier

The pilot identifier serves to connect a particular pilot to the job information stored in the data card and printed in the reports. A change of pilots during a job is noted on the reports. The identifier can be any alphanumeric string up to nine characters long.

To enter the pilot identifier, follow these steps.

1. Scroll through the Setup Data menu until you see a screen like this.

```
↑ Setup Data ↓  
Pilot:  J JENSEN ↔
```

2. Press the Right or Left key to place a cursor under the first character that can be changed.

```
Setup Data  
Pilot:_ J JENSEN ↔
```

3. Use the Right or Left keys to position the cursor under each character you want to change, and then use the Up or Down keys to scroll through the choices for that character. For example, you might enter this value.

```
Setup Data  
Pilot:K HILLEN _↔
```

4. When all changes have been made, press ENTER to save the new setting and move to the next menu selection.
5. If you are finished making changes in the Setup Data menu, use the Up or Down key to scroll to the Go To System Menu selection or the Go To Run selection. Press ENTER to display the selected screen.

Entering Aircraft Identifier

The aircraft identifier serves to connect a particular aircraft to the job data stored in the data card and printed in the reports. Depending on your need, the identifier might be the aircraft's tail number or serial number, or any other alphanumeric string up to nine characters long.

To enter the aircraft identifier, follow these steps.

1. Scroll through the Setup Data menu until you see a screen like this.

```
↑ Setup Data ↓  
Aircraft:N12345678↔
```

2. Press the Right or Left key to place a cursor under the first character that can be changed.

```
Setup Data  
Aircraft:N12345678↔
```

3. Use the Right or Left keys to position the cursor under each character you want to change, and then use the Up or Down keys to scroll through the choices for that character. For example, you might enter this value.

```
Setup Data  
Aircraft:N87654321↔
```

4. When all changes have been made, press ENTER to save the new setting and move to the next menu selection.
5. If you are finished making changes in the Setup Data menu, use the Up or Down key to scroll to the Go To System Menu selection or the Go To Run selection. Press ENTER to display the selected screen.

Setting Recording Mode

The recording mode setting allows you to select between automatic and manual recording modes. In automatic mode, the system automatically records any lift that exceeds both the minimum load and minimum lift time set. In manual mode, the system records the lift only when the pilot presses the capture switch.

If manual mode is set, the minimum lift load and minimum lift time information is not needed.

To set the system for automatic or manual recording, follow these steps.

1. Scroll through the Setup Data menu until you see an item like this.

```
↑ Setup Data ↓  
Op Mode:<AUTO> ↔
```

The angle brackets around the word "AUTO" indicate that in this example the current setting is for automatic recording.

2. Press the Right or Left key to access the following screen.

```
Setup Data  
Set Mode:MANUAL ↔
```

3. Use the Right or Left key to toggle between the choices until the desired selection is displayed.
4. Press ENTER to save the new setting and move to the next menu selection.
5. If you are finished making changes in the Setup Data menu, use the Up or Down key to scroll to the Go To System Menu selection or the Go To Run selection. Press ENTER to display the selected screen.

Setting Minimum Lift Load

The minimum lift load setting allows you to specify the minimum weight that determines a valid load. Defining a minimum load prevents the system from recording every small load that is applied to the hook. The minimum lift load setting can be any number up to four digits long, to a maximum of 9999. There is no scale in this function, entering 0400 means 400 LBs or KGs. The units legend (LB or KG) depends on the units setting. Refer to Setting *the Units Legend* later in this section.

If manual recording mode is set, this information is not needed.

To change the minimum lift load, follow these steps.

1. Scroll through the Setup Data menu until you see an item like this.

```
↑ Setup Data ↓  
Min Lift Load:0400↔
```

2. Press the Right or Left key to access the following screen. A cursor appears under the first digit. The display also indicates the units setting that is in effect.

```
Setup Data  
Min Load (LB):0400↔
```

3. Use the Right or Left keys to position the cursor under each digit you want to change, and then use the Up or Down keys to scroll through the setting choices for that digit.

```
Setup Data  
Min Load (LB):0250↔
```

4. When all changes have been made, press ENTER to save the new setting and move to the next menu item.
5. If you are finished making changes in the Setup Data menu, use the Up or Down key to scroll to the Go To System Menu selection or the Go To Run selection. Press ENTER to display the selected screen.

Setting Minimum Lift Time

The minimum lift time setting allows you to specify the length of time in seconds that a load must be carried to be recorded as a valid load. Defining a minimum time prevents the system from recording a quick tug on the hook as a valid load. The minimum lift time setting can be any integer up to three digits long, to a maximum of 999 seconds.

If manual recording mode is set, this menu item does not appear.

To change the minimum lift time, follow these steps.

1. Scroll through the Setup Data menu until you see an item like this.

```
↑ Setup Data ↓  
Min Lift Time:015 ↔
```

This example indicates a minimum lift time of fifteen seconds.

2. Press the Right or Left key to access the following screen. A cursor appears under the first digit.

```
Setup Data  
Min Time (sec):015↔
```

3. Use the Right or Left key to position the cursor under each digit you want to change, and then use the Up or Down keys to scroll through the setting choices for that digit.

```
Setup Data  
Min Time (sec):010↔
```

4. When all changes have been made, press ENTER to save the new setting.
5. If you are finished making changes in the Setup Data menu, use the Up or Down key to scroll to the Go To System Menu selection or the Go To Run selection. Press ENTER to display the selected screen.

Setting the Average Time

The average time sets the length of time that the load is averaged during a lift. The average time setting can be any number up to two digits long, to a maximum of 99 seconds. If the average time is zero, the load is averaged from the time the load exceeds the minimum lift time and lift load until the load is reduced by 75%.

If the system is set for manual mode this setting is not required.

To change the average time setting, follow these steps.

1. Scroll through the Setup Data menu until you see the average time entry. The time reads in seconds.

```
↑ Setup Data ↓  
Average Time:00 ↔
```

2. Press the Right or Left key to place a cursor under the first character that can be changed.

```
Setup Data  
Avg Time (sec):00 ↔
```

3. Use the Right or Left key to position the cursor under each digit you want to change, and then use the Up or Down keys to scroll through the choices for that digit.

```
Setup Data  
Avg Time (sec):45 ↔
```

4. When all changes have been made, press ENTER to save the new setting and move to the next menu selection.
5. If you are finished making changes in the Setup Data menu, use the Up or Down key to scroll to the Go To System Menu selection or the Go To Run selection. Press ENTER to display the selected screen.

Setting the Average Start Time

The average start time is the time after a lift has exceeded the minimum start time and minimum lift load and before the average time begins. The average start time setting can be any number up to two digits long, to a maximum of 99 seconds. If the average start time is zero, the average time begins when the load exceeds the minimum lift time and lift load.

If the system is set for manual mode this setting is not required.

To change the average start time setting, follow these steps.

1. Scroll through the Setup Data menu until you see the average start time entry. The time reads in seconds.

```
↑ Setup Data ↓  
Avg Start Time:00 ↔
```

2. Press the Right or Left key to place a cursor under the first character that can be changed.

```
Setup Data  
Start Time(sec):00↔
```

3. Use the Right or Left key to position the cursor under each digit you want to change, and then use the Up or Down keys to scroll through the choices for that digit.

```
Setup Data  
Start Time(sec):45↔
```

4. When all changes have been made, press ENTER to save the new setting and move to the next menu selection.
5. If you are finished making changes in the Setup Data menu, use the Up or Down key to scroll to the Go To System Menu selection or the Go To Run selection. Press ENTER to display the selected screen.

Entering the Date

The date setting helps identify job data and is printed on the job report. The date is updated by the data recorder clock, which is powered by an internal lithium battery. Once set, the correct date should remain in the system as long as the battery is good.

Check the data occasionally to ensure that it is correct. For information on the battery, read *C-30 Internal Battery* at the end of this section.

To change the date setting, follow these steps.

1. Scroll through the Setup Data menu until you see the date entry. The format of the date is MM/DD/YY.

```
↑ Setup Data ↓  
Date: 05/28/00 ↔
```

2. Press the Right or Left key to place a cursor under the first character that can be changed.

```
Setup Data  
Set Date: 05/28/00↔
```

3. Use the Right or Left keys to position the cursor under each digit you want to change, and then use the Up or Down keys to scroll through the choices for that digit.

```
Setup Data  
Set Date: 05/29/00↔
```

4. When all changes have been made, press ENTER to save the new setting and move to the next menu selection.
5. If you are finished making changes in the Setup Data menu, use the Up or Down key to scroll to the Go To System Menu selection or the Go To Run selection. Press ENTER to display the selected screen.

Entering the Time

The time setting is used to identify the job data. The start time and duration of each lift is printed in the reports. The time is controlled by the data recorder clock. Once set, the correct time should remain in the system as long as the battery is good.

Check the time occasionally to ensure that it is correct. For information on the battery, read *C-30 Internal Battery* at the end of this section.

To change the time setting, follow these steps.

1. Scroll through the Setup Data menu until you see the time entry. The format of the time display is HH:MM:SS using a 24-hour clock.

```
↑ Setup Data ↓  
Time: 13:42:58 ↔
```

2. Press the Right or Left key to place a cursor under the first character that can be changed.

```
Setup Data  
Set Time: 13:42:58↔
```

3. Use the Right or Left keys to position the cursor under each digit you want to change then use the Up or Down keys to scroll through the choices for that digit.

```
Setup Data  
Set Time: 14:35:00↔
```

4. When all changes have been made, press ENTER to save the new setting and move to the next menu selection.
5. If you are finished making changes in the Setup Data menu, use the Up or Down key to scroll to the Go To System Menu selection or the Go To Run selection. Press ENTER to display the selected screen.

Specifying Flight-Time Switch Polarity

You set flight-time switch polarity to specify the type of connection used by the flight-time switch wiring. The correct setting depends on how this user-supplied switch is installed. There are two menu settings: High specifies that the switch connects the data recorder to an airframe ground source during flight; Low specifies that the switch disconnects the data recorder from airframe ground during flight.

Follow these steps to specify the flight-time switch polarity.

1. Scroll through the Setup Data menu until you see an item like this.

```
↑ Setup Data ↓  
Flt Switch:<HIGH> ↔
```

The angle brackets around the High selection in this example indicate that when the aircraft is in flight, the flight-time wire of the data recorder is connected by the switch to airframe ground. When the aircraft is on the ground, the switch disconnects the wire from airframe ground.

2. Press the Right or Left key to access the following screen.

```
Setup Data  
Polarity:LOW ↔
```

3. Use the Right or Left key to toggle between High and Low until the desired selection is displayed. Select Low if the flight time counts when the flight-time wire is disconnected from airframe ground.
4. Press ENTER to save the new setting and move to the next menu item.
5. If you are finished making changes in the Setup Data menu, use the Up or Down key to scroll to the Go To System Menu selection or the Go To Run selection. Press ENTER to display the selected screen.

Setting the Units Legend The units legend setting allows you to set the data recorder screens and report printouts to list values using either pounds (LB) or kilograms (KG). The data recorder should be set to match the output of your C-39 indicator. The C-39 indicator's output scale can be changed by the operator.

Follow these steps to set the units of measurement display.

1. Scroll through the Setup Data menu until you see this item.

```
↑ Setup Data ↓  
Units:<LB> ↔
```

The angle brackets around the legend "LB" in this example indicate that load weight measurements will display the legend in pounds.

2. Press the Right or Left key to access the following screen.

```
Setup Data  
Set Units:KG ↔
```

3. Use the Right or Left key to toggle between the LB and KG until the desired selection is displayed.
4. Press ENTER to save the new setting and move to the next menu item.
5. If you are finished making changes in the Setup Data menu, use the Up or Down key to scroll to the Go To System Menu selection or the Go To Run selection. Press ENTER to display the selected screen.

Setting Dampening

Dampening is a software routine, located in the C-39 that averages the peaks and valleys before the load reading is displayed to the pilot. This makes the display more stable. The C-39 dampening level is pilot selectable from 1–9. The higher the number the more the load is dampened.

It is necessary to set the C-30 dampening to the same level as it is in the C-39. Later models of the C-39 transfer this information automatically. If you have a C-39 indicator with version numbers of 21 or higher it is not necessary to set the dampening level in the C-30.

To enter the dampening menu, follow these steps.

1. Scroll through the Setup Data menu until you see an item like this:

```
↑ Setup Data ↓  
Damping: <3> ↔
```

2. Press the Right or Left key to access the following screen.

```
Setup Data  
Damping: 3 ↔
```

3. Use the Up or Down key to change the dampening setting until the desired selection is displayed.
4. When all changes have been made, press ENTER to save the new setting and move to the next menu item.
5. If you are finished making changes in the Setup Data menu, use the Up or Down key to scroll to the Go To System Menu selection or the Go To Run selection. Press ENTER to display the selected screen.

Managing the Customer List

The customer list links job data to a particular customer. When work is performed for several customers, a separate job report can be generated for each customer. The customer names can be any alphanumeric string up to nine characters long. Up to ten customers can be entered and this information will be stored until it is changed.

To enter or edit customer names, follow these steps.

1. Scroll through the System Menu until you see this screen:

```
↑ System Menu ↓  
Manage Customer List
```

2. Press ENTER and use the Up or Down arrow key to scroll to the customer that needs to be changed or added.
3. Press the Right or Left key to place a cursor under the first character that can be changed.

```
Customer # 4  
_BILL
```

4. Use the Right or Left key to position the cursor under each character you want to change, and then use the Up or Down keys to scroll through the choices for that character. For example, you might enter this value.

```
Customer # 4  
JERRY
```

5. When all changes have been made, press ENTER to save the new setting and then use the Up or Down key to scroll to the next customer.
6. If you are finished making changes in the Customer List menu, select the desired customer by using the Up or Down arrow key until the correct customer appears and then press ENTER to get back to the System Menu.

NOTE

Be sure that when you exit out of the Manage Customer List menu, the correct customer has been selected. The flight information will be recorded for the customer last selected. To verify customer or change to another customer, follow the procedures on the following page.

To access the Customer List menu from the Run screen, follow these steps.

- 1. If accessing during flight, press the Up or Down arrow key to end the turn.**

If the turn is not ended and a new customer is selected, the last lift will be added to the new customer. Press the Up or Down key to end the turn.

2. Press the Up *and* Down arrow keys simultaneously to access the System Menu. You should see Manage Customer List on the screen, press ENTER.
3. Follow the guidelines on the previous page to select, add or change customers.

Managing the Location List

The location list helps to further describe work done for a particular customer on the job report. The locations can be changed at any time between lifts, and the lifts corresponding to each location are indicated on the report. The locations can be any alphanumeric string up to nine characters long. Up to ten different locations can be entered and will remain stored until they are changed.

To enter or edit locations, follow these steps.

1. Scroll through the System menu until you see this screen:

```
↑ System Menu ↓  
Manage Location List
```

2. Press ENTER and use the Up or Down arrow keys to scroll to the location that needs to be changed or added.
3. Press the Right or Left key to place a cursor under the first character that can be changed.

```
Location # 3
```

4. Use the Right or Left keys to position the cursor under each character you want to change, and then use the Up or Down keys to scroll through the choices for that character. For example, you might enter this value.

```
Location # 3  
Vancouver
```

5. When all changes have been made, press ENTER to save the new setting and then use the Up or Down arrow keys to scroll to the next location.
6. If you are finished making changes in the Location List menu, select the desired location by using the Up or Down arrow keys until the correct location appears and then press ENTER to get back to the System Menu.

NOTE

Be sure that when you exit out of the Manage Location List menu, the correct location has been selected. The flight information will be recorded for the location last selected. To verify location or change to another location, follow the procedures on the following page.

To access the Location List menu from the Run screen, follow these steps.

- 1. If accessing during flight, press the Up or Down arrow key to end the turn.**

If the turn is not ended and a new location is selected, the last lift will be added to the new location. Press the Up or Down key to end the turn.

2. Press the Up *and* Down arrow keys simultaneously to access the System Menu. Use the Up or Down arrow keys to scroll to Manage Location List and then press ENTER.
3. Follow the guidelines on the previous page to add or change locations.

Entering Company Data

The Company Data menu allows you to enter standard information about your company, such as name, address, and phone number. This information is printed in the header at the top of all reports. Six lines of 20 characters each are available. Entering data on these lines is optional.

To access the Company Data menu from the Run screen, follow these steps.

1. Press the Up *and* Down keys simultaneously to access the System Menu.
2. Use the Up or Down keys to display the Company Data selection.

```
↑ System Menu ↓  
Enter Company Data
```

3. Press ENTER. You can now scroll through the lines in the Company Data menu loop. Figure 3-4 shows the Company Data menu loop with example entries for the fictional company Rotor-to-Order.

To enter company data, follow these steps.

1. Access the Company Data menu as described above. A display like this appears.

```
↑ Company line:1 ↓
```

2. Press the Right or Left key to access the following screen. A cursor appears in the first position on the second line of the display.

```
Enter Company line:1  
_
```

3. Use the Up or Down keys to scroll through the character choices — A-Z, 0-9, space, hyphen, slash, apostrophe, and period. When the desired character is displayed, use the Right or Left keys to place the cursor under the next position where you want to change or enter a character.
4. When all changes have been made to the first line of company data, press ENTER to save the new setting and move to the next line.
5. Edit Lines 2 through 6 as you did for Line 1.
6. When you are finished, return to the System Menu or the Run screen by pressing ENTER when the appropriate choice is displayed.

Figure 3-4 Company Data menu loop

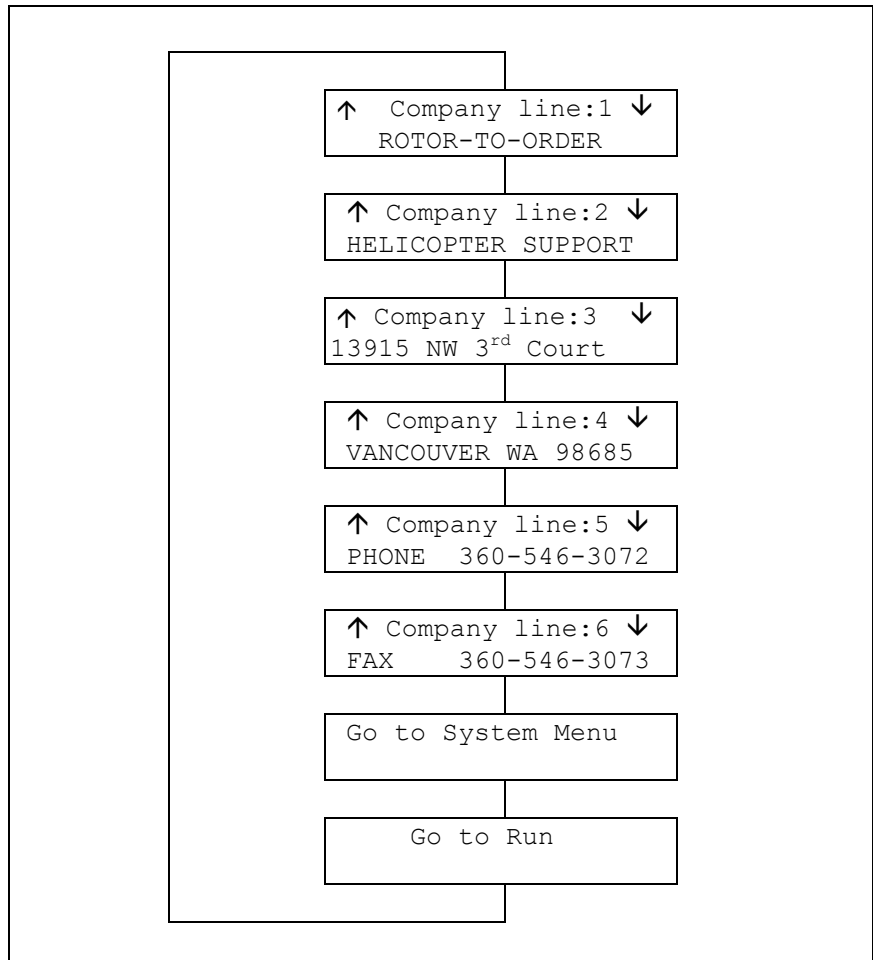

Using the Utilities Menu

The Utilities menu displays the system version number and allows you to adjust the display contrast, adjust the display backlight and erase a data card.

To access the Utilities menu from the Run screen, follow these steps.

1. Press the Up *and* Down keys simultaneously to access the System Menu.
2. Use the Up or Down keys to display the Utilities selection.

```
↑ System Menu ↓  
Utilities
```

3. Press ENTER. You can now scroll through the lines in the Utilities menu loop, shown in the example in Figure 3-5.

Figure 3-5 Utilities menu loop

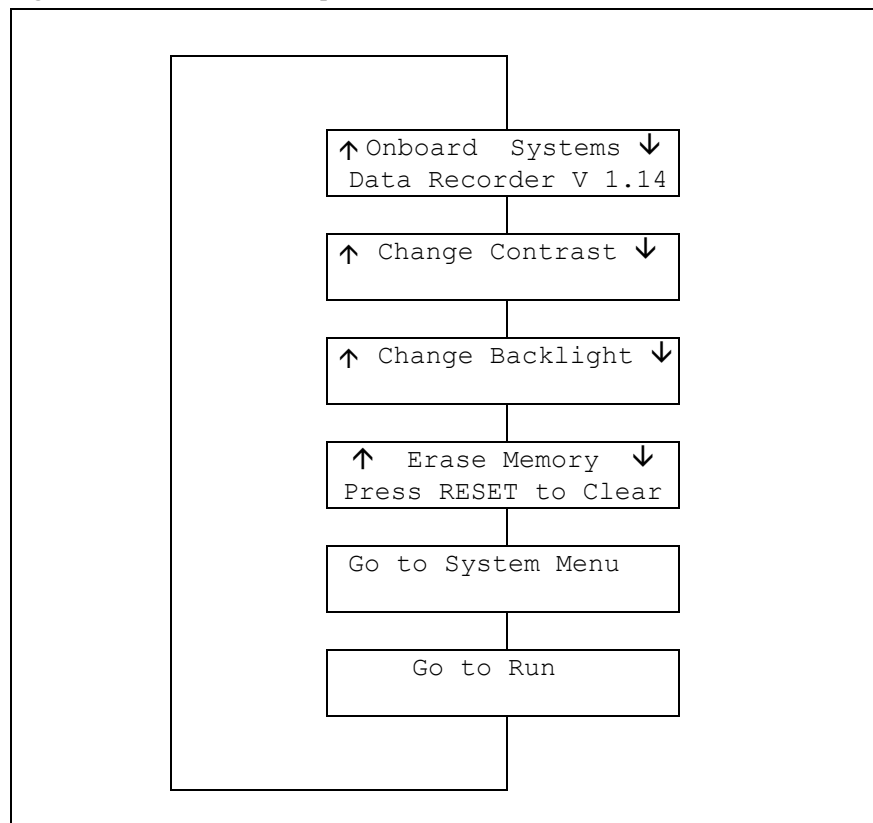

Viewing the Software Version Number

The first screen in the Utilities menu displays the version number of the data recorder software.

To view the version number, follow these steps.

1. Scroll through the Utilities menu until you see a screen similar to this example.

```
↑ Onboard Systems ↓  
Data Recorder V 1.14
```

2. Press the Down key to move to the next menu screen, or press the Up key to get the Go to Run screen.

Adjusting the Display Contrast

The data recorder display is equipped with adjustable contrast control. Setting the contrast adjusts the display to help compensate for different viewing angles.

To change the contrast setting, follow these steps.

1. Go to the Change Contrast menu in the Utilities menu loop.
2. Press the ENTER key to enter the change menu. The display should look like this.

```
Change Contrast  
***** -----
```

3. Use the Right or the Left arrow keys to change the contrast.
4. Press the ENTER key when the desired contrast is achieved.

Adjusting the Back-Lighting

The data recorder display includes an electroluminescent back-lighting feature. Back-lighting helps compensate for different ambient lighting conditions.

To change the intensity of the back-lighting, follow these steps.

1. Go to the Change Backlight menu in the Utilities menu loop.
2. Press the ENTER key to enter the change menu. The display should look like this.

```
Change Backlight
***** -----
```

3. Hold down the Right arrow key to increase the backlight intensity.
4. Hold down the Left arrow key to reduce the intensity.
5. Press the ENTER key when the desired intensity is achieved.

Erasing Memory

The data recorders internal memory stores all of the accumulated flight and lift information. Once the data is retrieved by a data card or laptop, the data recorder's internal memory should be erased.

To erase the internal memory of the data recorder, follow these steps.

1. Go to the Erase Memory menu in the Utilities menu loop.
2. Press the RESET key to enter the Erase Memory menu. The display should look like this.

```
Erase Current Data?
Enter to confirm
```

3. Press the ENTER key to erase the internal memory. The display should look like this.

```
Formatting Memory
***** -----
```

4. Press the RESET key to escape out of the Erase Memory menu and return to the Utilities menu.

Using the Options Menu

The Options menu allows you to enable and disable installed options.

Options menu entries include these items.

- Internal Accelerometer
- External Accelerometer
- Keypad

To access the Options menu from the Run screen, follow these steps.

1. Press the Up *and* Down keys simultaneously to access the System Menu.
2. Use the Up or Down keys to display the "Options" selection.

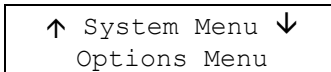

3. Press ENTER. You can now scroll through the selections in the Options menu loop shown in Figure 3-6.

Figure 3-6 Options menu loop

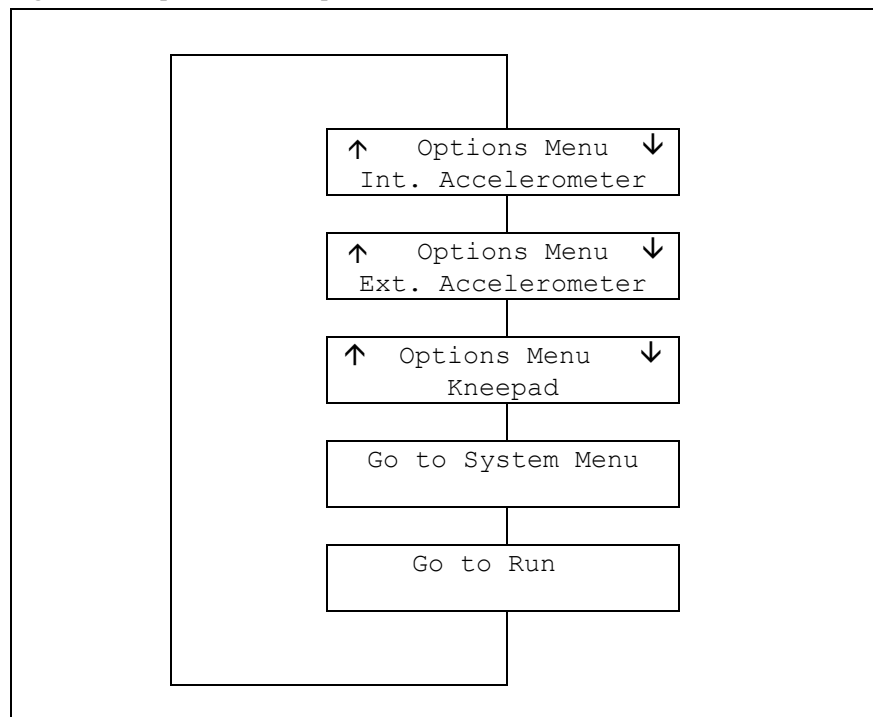

Internal Accelerometer

The data recorder is equipped with internal accelerometers. They are used to determine the optimum time for the data recorder to record a lift, when the system is set to Auto mode. Refer to the *Setting the Recording Mode* section. This feature is not affected by enabling or disabling the accelerometers.

The internal accelerometers are also used to correct the recorded lift weight for the effect of acceleration. This feature is turned off when the internal accelerometers are disabled.

To access the Internal Accelerometer menu from the Options screen, follow these steps.

1. Scroll through the Options menu until you see this screen:

```
↑ Options Menu ↓  
Int. Accelerometer
```

2. Press ENTER. You can now scroll through the selections in the Internal Accelerometer menu loop shown in Figure 3-7.

Figure 3-7 Internal Accelerometer menu loop

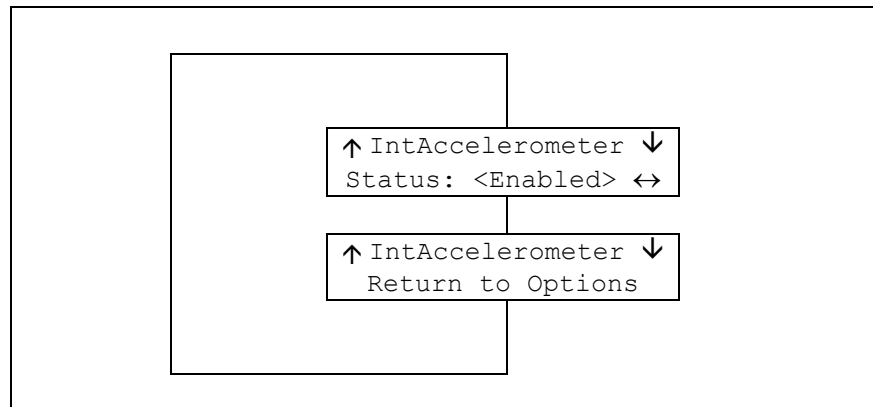

Status

The internal accelerometers can be turned on or off at the status menu.

To enter the status menu, follow these steps.

1. Scroll through the Internal Accelerometer menu until you see an item like this:

```
↑ IntAccelerometer↓  
Status: <Enabled> ↔
```

2. Press the Right or Left key to access the following screen.

```
↑ IntAccelerometer↓  
Status: Disabled ↔
```

3. Use the Right or Left key to toggle between enabled and disabled.
4. When all changes have been made, press ENTER to save the new setting and move to the next menu selection.
5. If you are finished making changes in the Internal Accelerometer menu, use the Up or Down key to scroll to the Return to Options Menu selection. Press ENTER to display the selected screen.

Using the Run Screen

The Run screen is the screen that appears when you turn on the data recorder. It is displayed during normal operation. The Run screen must be displayed to record lift data. If a screen other than the Run screen appears on power up, refer to *Attention Messages* at the end of this section for more information.

Several types of information can be displayed on the Run screen, as described in the following paragraphs.

During a Lift

Figure 3-8 shows an example of the Run screen as it appears during lift operations. The first line of the Run screen shows the weight of the load, the flight status indicator, and any load weight captured using the optional capture switch. The flight status indicator appears as follows:

- ↓ Ground indicator. The flight has not yet begun, or the flight has ended.
- ↑ Flight indicator. The aircraft is in flight but is not performing a lift. Flight time is accruing.
- Lift indicator. A load is being carried. Turn time and flight time are accruing. The indicator and lift information appear when lift load and time minimums are met.
- ← Turn indicator. The load has been dropped and the aircraft is returning for another load. Turn time and flight time are accruing. Turn time is the time from the beginning of one lift to the beginning of the next lift.

Figure 3-8 Run screen with lift information

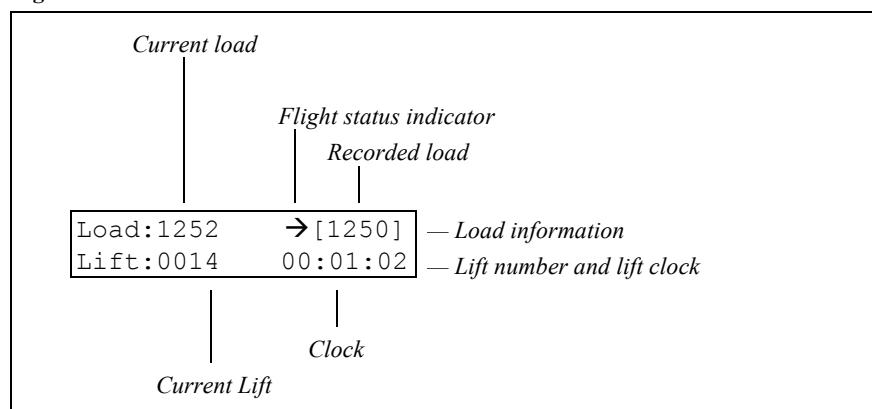

Viewing Customer Totals

You can also use the Run screen to display flight and lift totals for a particular customer. This feature allows you to display summary customer data in the cockpit. Two screens of customer information are available; one shows the number of flights and total flight time, the other shows the number of lifts and total load.

To view the customer totals:

1. If needed, use the Manage Customer List menu to set the customer identifier to the name of the customer whose data you want to view.
2. Return to the Run screen, then press the Right or Left key one or more times until the desired data is displayed.

NOTE

If you begin a lift when a customer totals screen is displayed, the lift data Run screen automatically appears. The current customer identifier setting is used to identify the lift.

Figure 3-9 shows examples of Run screens with customer totals.

Figure 3-9 Run screens with customer totals

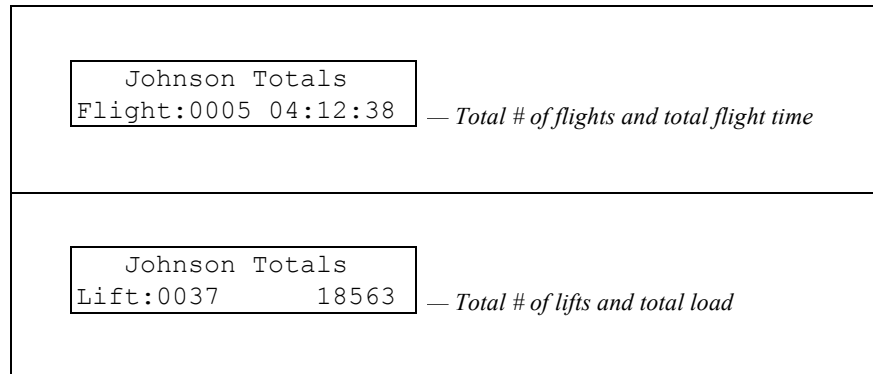

How Lifts Are Recorded

Determining When a Lift is Recorded

The system uses two methods to determine when a lift is recorded, manual and automatic. The setup menu is used to select between automatic and manual. See sections *Setting Recording Mode*.

Manual Method

The pilot can use the capture switch at any time during a lift to record a lift manually. The captured weight is not averaged, it is the weight of the load at that moment. If the capture switch is again activated the first record is replaced by the new captured weight, only the last record is kept. The capture switch can also be used when the system is in the automatic recording mode. Activating the capture switch will overwrite lifts recorded automatically. If the system is in the manual recording mode and the capture switch is not activated during the lift, no record of the lift will be made. The PC report will list how the lift was recorded, automatic or manual.

Automatic Method

The automatic method uses the minimum lift load and the minimum lift time settings. When the weight of the load exceeds the weight entered into the minimum lift load and the load is carried for a period of time that exceeds the time entered into the minimum lift time the lift is recorded.

Determining the Weight of a Lift

The system uses two methods to determine the weight of a load. One is manual and another is average.

Manual Method

At any time during a lift the pilot can use the manual switch to capture a lift. The captured weight is the weight of the load at that moment. If the internal accelerometers are enabled the captured weight will be corrected for acceleration and the report note will be <cap><acc>. If the internal accelerometers are disabled the captured weight will be the uncorrected weight and the report note will be <cap><std>. The capture switch overwrites any automatic records. The manual switch can be used repeatedly during a lift, only the last capture is recorded.

Automatic Method

The automatic method uses the setting in the average time and average start time. When the average time clock begins the system repeatedly computes the standard deviation for both the accelerometer corrected and uncorrected weights and the standard deviation with the lowest value is used as the weight of the load.

If the internal accelerometers are enabled and the standard deviation for the accelerometer corrected weight is the lowest the report will show (acc) to indicate the recording method. If the standard deviation for the uncorrected weight is the lowest the report will show (std). If the internal accelerometers are disabled the recorded weight will be the uncorrected weight and the report note will be <std>.

If the load is dropped before the average time has expired, the computations are done over the time the data was gathered. If the load is dropped before minimum lift time has expired or minimum weight value met, no lift is reported.

Improving the Accuracy of Lifts Recorded Automatically

The accuracy of the recorded load can be optimized by understanding how the system records the weight. Illustrated below is a graphical representation of a lift profile. It shows the load being picked up and carried for a period of time before being set down. It's not particularly realistic as the initial vertical acceleration and drag are not shown.

Figure 3-10 Load Profile

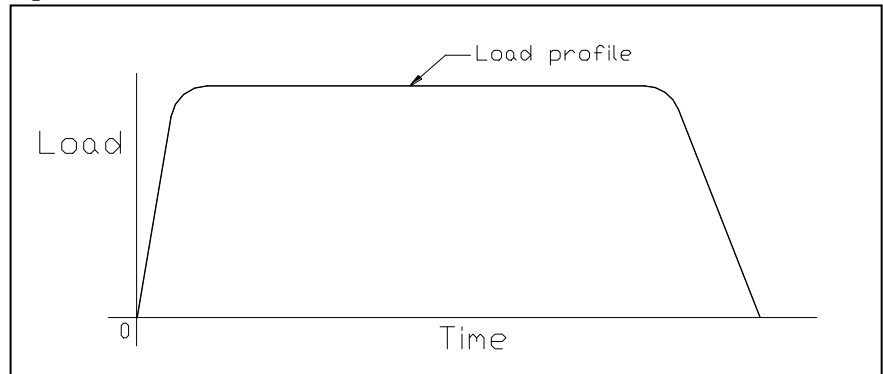

A somewhat more accurate, though exaggerated for illustration purposes, is the load profile in Figure 3-11. This shows the initial vertical acceleration and the increase in airframe load due to drag. Not illustrated in this figure is the initial jerking that may be present and the bounce that may occur after transition.

Figure 3-11 Exaggerated Load Profile

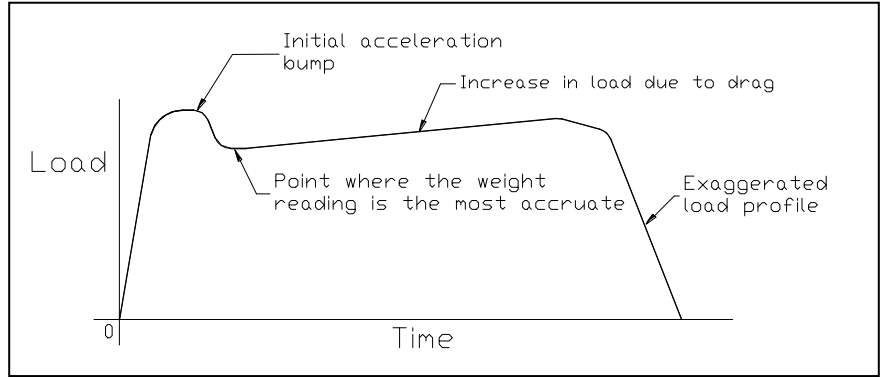

No two load profiles are the same but, with an understanding of their common elements such as initial acceleration, bounce, drag and time and an understanding of the previous section, fairly accurate records are possible.

Putting it all together a typical automatic setup, with the internal accelerometers enabled, might look like this.

Figure 3-12 Typical Automatic Setup

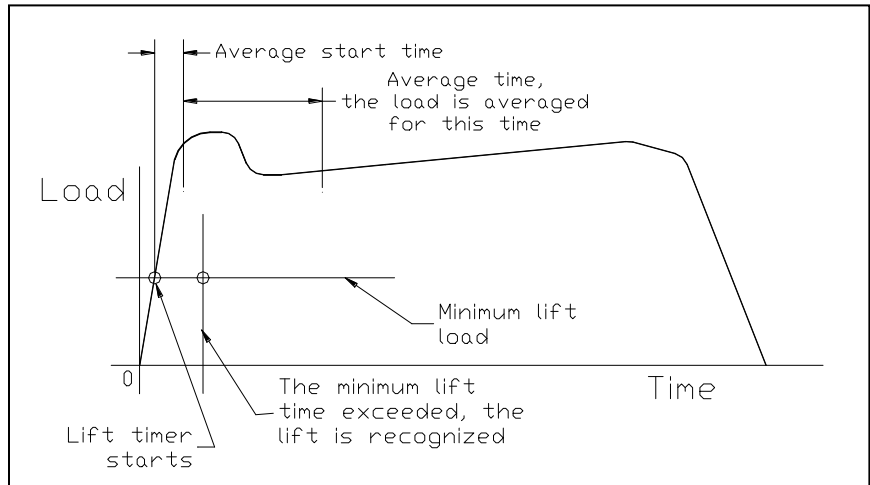

Note that the average time includes the initial jerking that may be present as the load clears the ground. The internal accelerometers should take care of the initial acceleration bump and the average time ends prior to the introduction of significant drag.

A longer average time could be used to gain more accuracy if the load did not introduce significant drag.

If the internal accelerometers are disabled the system calculates the standard deviation for the uncorrected weight only. For the optimum accuracy the average start time should be moved out to miss the initial acceleration bump as illustrated in Figure 3-13.

Figure 3-13 Increasing average start time

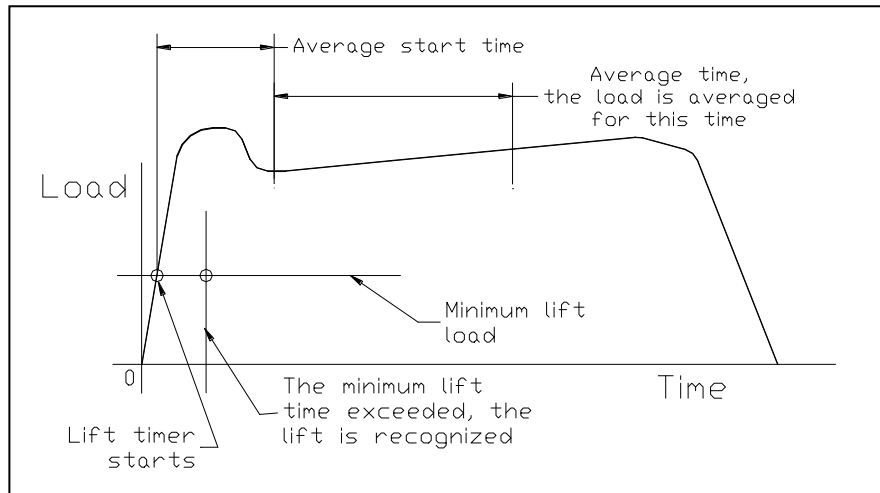

Recording a Flight and Lift

This procedure describes the steps you follow to record a flight and lift data. See fig 3-14.

1. Turn on the power to the weighing system and the data recorder.
2. Use the Setup Data and Company Data menus to change any menu settings, as needed.
3. Ensure that the Run screen or one of the customer total screens is displayed. See Figure 3-14a.

Load:	0	↓	(0)
Flight:	000		00:00:00	

4. The zero button on the weighing system indicator can be used to zero the load readings on both the indicator and the data recorder. See C-39 operation for tare weights.

NOTE

You can use the data recorder as a remote indicator.

5. Begin the flight. The flight counter starts and the ground indicator ↓ changes to the flight indicator ↑. See Figure 3-14b.

Load:	0	↑	(0)
Flight:	001		00:00:01	

6. Begin a lift. When both the minimum lift time and minimum lift load are met, the system records a lift. On the Run screen, the load weight registers and the lift indicator → appears. The lift data line appears, the lift counter increments, and the lift clock begins counting. See Figure 3-14c.

The system displays and records the full duration of the lift, even if a minimum lift time is set. For example, if the minimum lift time is five seconds, the display looks something like this when the lift indicator first appears.

Load:	1251	→	<1251>
Lift:	0001		00:00:05

During manual operations, the pilot must press the capture switch to begin recording a lift. During automatic operations, if the pilot presses the capture switch at any time during the lift, the data recorder captures the weight of the load that is measured at the moment the switch is pressed and applies that weight to the entire lift. See Figure 3-14d. The measurement can be recaptured at any time during the lift; only the last value is saved. The captured load weight appears next to the current load display.

Load:1250	→ [1250]
Lift:0001	00:01:02

If a capture switch is not used during automatic recording, the average weight of the load during the lift is recorded.

7. For both automatic and manual recording, flight information and the turn indicator ← appear when the load is reduced by 75%.

Load: 312	← [1250]
Flight:001	00:04:13

For example, if the load weighs 1000 pounds, lift timing ends when the system registers 250 pounds. Turn time accrues until the next load is picked up or the flight ends. See Figure 3-14e.

8. Repeat Step 7 for all the lifts you want to record on this flight.
9. Landing the aircraft ends the current flight. There is a 20-second delay before the ground indicator appears.

Changing new customer information ends the current flight and begins a new flight. This can be done at any time during a flight.

Figure 3-14 Recording a lift

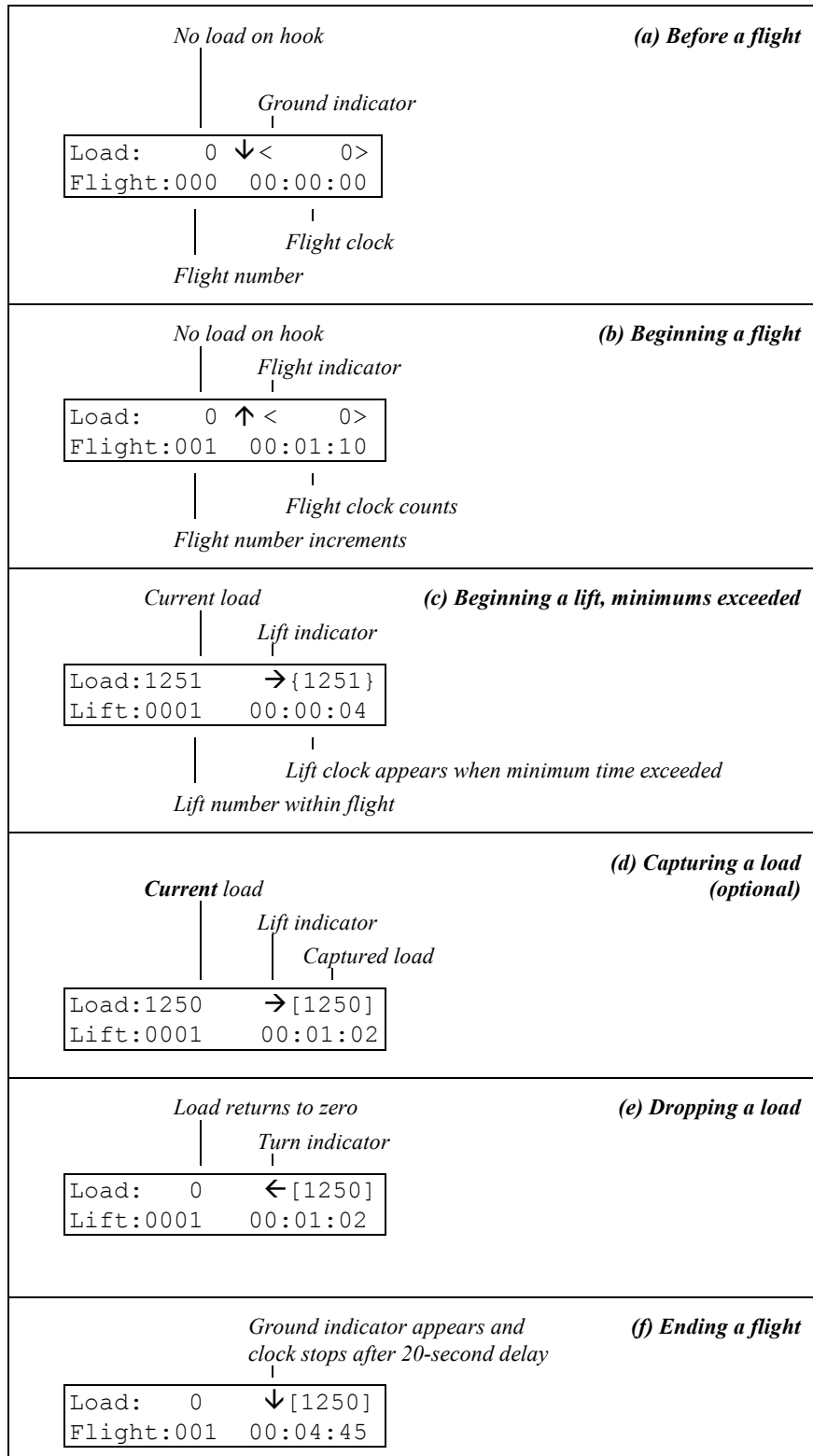

C-30 Internal Battery

When the data recorder is turned on, it is powered by the aircraft electrical system. When the data recorder is turned off or is disconnected, its internal memory and clock are maintained by a lithium battery inside the data recorder. The projected battery life is 10 years. The indication that the battery life is at its end is inconsistent clock and date readings.

The unit should be returned to the factory for battery replacement.

Attention Messages

The data recorder displays certain messages when an action other than normal operation is required.

System Conditions

System condition messages indicate a situation with data card system hardware that requires pilot attention.

```
No data from hook  
Flight: 1 00:00:10
```

The data card system is not receiving information from the C-39 indicator. There are four possible causes for this condition.

1. The load cell is not connected to the internal wiring harness.
2. There is no power to the indicator, but there is power going to the data recorder.
3. The C-39 indicator is in some mode other than run.
4. The transmitting circuits in the C-39 indicator are defective. The indicator and data recorder should be returned to the factory for inspection and service.

```
Memory is >80% full  
Copy to a Card
```

The system memory is nearing its memory capacity. The data must be down loaded or it will be overwritten by new data when it reaches 100% capacity. Save the data by connecting a PC to the serial port or inserting a data card.

Section 4

Operating the Printer

This section describes operation of the optional C-23 Printer. Here are the topics in this section.

- *Turning on the Printer*
- *Printing a Self Test*
- *Installing the Paper*
- *Installing Cartridge Ribbon*
- *Clearing a Paper Jam*
- *Printing a Report*
- *Reading a Report*

Turning on the Printer

The C-23 Printer should be turned on after the load weigh system is powered up. The power switch has three positions. The OFF position is all the way to the left, the ON position is in the center, and the PAPER FEED position is all the way to the right. To turn the printer on, follow these steps.

1. Turn on the printer by pushing the POWER switch down on the right side. Now release the switch and it will remain in the center ON position.
2. The power LED should now be lit and a READY message should have been printed.
3. When turning the printer off, wait at least 3 seconds before turning the printer back on.

Printing a Self-Test

The print head and ribbon can be tested *only after inserting paper*. *Do not print without paper*. To print a self-test follow these steps.

1. Make sure the printer is in the OFF position.
2. Depress power switch until it reaches PAPER FEED position.
3. Hold the switch in the PAPER FEED position until the LED light goes on and the printer starts to operate. Release switch.
4. To stop the printer during the self-test or at any other time, turn the power switch to the OFF position and wait 3 seconds to turn it back on.

Installing the Paper

The C-23 printer uses a 2.25-inch roll paper, available as Part Number 215-051-00. To install a roll of paper in the printer compartment, follow these steps.

1. Press the power switch to the OFF position.
2. There are small grooves embossed on the printer cover, push down on the grooves using both your index fingers. The printer cover will tilt up, then lift the lid completely off.
3. Unroll several inches of the paper. Cut a straight edge on the paper roll if it is jagged. This will facilitate the entry of the paper into the printer.
4. Slide the paper through the slot connecting the paper compartment and the printer compartment. You can slide it in about one-quarter inch before it stops.
5. Press the power switch to the ON position and wait for a few seconds.
6. While holding the paper in place, press the power switch to the PAPER FEED position. The printer will activate, and a rubber roller will pull the paper into the printer compartment. Hold the switch in the PAPER FEED position until the paper emerges from the top of the printer mechanism. When an inch of paper has emerged from the top of the printer, release the PAPER FEED button.
7. Now pull the paper through the printer, until several inches are exposed.
8. Replace the printer cover by sliding the paper through the slot in the printer cover. Push the back of the printer cover down and into place. Press the front of the printer cover down to lock in place.
9. Put the paper roll holder into the paper roll and place the holder onto the grooves near the back of the printer. Turn the paper roll so as to take up any slack in the paper feeding to the printer. Make sure the roll of paper moves freely. If it does not move freely, the paper will jam and will possibly damage the printer mechanism.

Installing the Cartridge Ribbon

When printing becomes faint or difficult to see, the cartridge should be replaced. The ribbon is available as Part Number 212-006-00. To install a cartridge ribbon in the printer, follow these steps.

1. Press the power switch into the OFF position.
2. Remove the printer cover following the procedures above.

Installing the Cartridge Ribbon, continued

3. Push down on the right side of the ribbon cartridge (marked "PUSH") and remove the cartridge.
4. Install the new cartridge. Be sure the ink cartridge is inserted firmly to prevent weak or irregular printing. The cartridge must be properly seated and aligned for best printing.
5. Turn the cartridge "knob" (marked by an arrow) clockwise to stretch the ribbon.
6. Replace the cover following the procedures above.
7. Replace the paper.

You may also insert the ribbon cartridge if there is already paper in the printer. Follow the steps above. Slide the cartridge over the paper and into the printer compartment. Be sure the paper goes between the ribbon cartridge and the ink ribbon.

NOTE

If ribbon ink gets on the printer case, wipe it off immediately. Once it dries, it is difficult to remove.

Clearing a Paper Jam

If paper jams in the C-23 Printer, follow these steps to clear the jam.

1. Press the power switch into the OFF position.
2. Remove the printer cover following the procedures on the previous page.
3. To remove the paper roll, lift the paper roll away from the printer housing. With a pair of scissors cut the paper feeding to the printer. Try to make the cut as square as possible to facilitate the next reloading of the paper. Now pull the remaining paper through the printer mechanism. Be sure to pull the paper from the front (paper cutter side).



Never pull the paper backwards from the printer.

4. Carefully clear the jam, and replace the printer cover.

Printing a Report

The C-23 Printer can print a report whenever and as often as needed. Printing a report does not erase or change the information stored in the data recorder.

A full report or a summary can be printed for either a single customer or all customers. Table 4-1 shows the possible types of report selections.

Follow these steps to print a lift report from the data recorder.

1. Connect the printer to the data recorder printer connector.
2. Turn on system power.
3. Press the ENTER button while the Run screen is displayed. The print format selection screen appears.

```
Print Format
Format: <Summary> ↔
```

4. Use the Right or Left keys to select Summary to print summary information about the lifts, or select Report to print a full lift report.
5. Press ENTER to enter your selection and display the next screen, the customer selection screen.

```
Select Customer:
<HAYES ENT> ↔
```

6. Press the Right or Left key to loop through the list of customer until the desired name is displayed, or display ALL to print data for all customers.
7. Press ENTER to enter your selection and print the report.

Table 4-1 Report types and their screen selections

Report type	FORMAT screen	CUSTOMER ID screen
Full report, all customers	REPORT	ALL
Full report, one customer	REPORT	<customer>
Summary, all customers	SUMMARY	ALL
Summary, one customer	SUMMARY	<customer>

NOTE

Printing in KG Units

When printing in KG units from the C-30 to the C-23 it is required that the units be reset each time that the C-30 is powered off and on. Go to the Units entry and using the left and/or right arrow buttons change the entry to LB then back to KG. Press Enter to accept the KG legend. You are now ready to return to the Run screen and print your report.

Reading a Report

The information printed in a data recorder report or summary depends on the options you select when you request the report. All reports show sections that contain company data and summary flight statistics. A full report includes sections with detailed lift logs by customer.

The various report sections contain the following information.

- The *report header* contains the information stored in Lines 1 – 6 of the Company Data menu.
- The *customer header* lists information stored in the Setup menu, including customer identification and location, and aircraft and pilot identification.
- The *date* is the date the information was stored.
- The *flight detail* includes a header with flight number, start time, end time and duration; lift detail for each lift, including lift number, load, start time, load and time minimum designator, and turn time; and an end-of-flight footer.
- The *flight summary* supplies the number of flights and lifts for the customer, and totals and averages for flight time, weight, and turn time.
- The *codes for minimum settings* are automatically assigned by the system whenever a lift is performed with a different combination of minimum load and minimum lift time. These codes are designated by letters, starting with A, that appear next to the start time in the lift detail. An asterisk * indicates the weight of a load that was captured.
- The *report footer* shows the model number and manufacturer information for the printer.

Figure 4-1 is an example of a full report from a data card storing information about two customers; Figure 4-2 is a summary for one of those customers. Table 4-2 shows which report sections are printed on a report and a summary.

Figure 4-1 An example full report

<p><i>Report Header</i> (from Lines 1 – 6 of the Company Information menu)</p>	<p>ROTOR-TO-ORDER HELICOPTER SUPPORT 13915 NW 3rd Court VANCOUVER WA 98685 PHONE 360-546-3072 FAX 360-546-3073</p>	<p><i>Customer 1 Flight Summary</i></p>	<p>***** * Totals & Averages * ***** Flights: 2 T Flt Time: 00:03:59 A Flt Time: 00:01:59 Lifts: 4 T Weight: 20190LB A Weight: 5047LB T Trn Time: 00:03:34 A Trn Time: 00:00:53 *****</p>	
<p><i>Customer 1 Header</i></p>	<p>***** Customer: TERRY T. Location: ZONE 102 Aircraft: ONB-07970 Pilot ID: KARSTEN *****</p>	<p><i>Customer 2 Header</i></p>	<p>Customer: JASON Location: HILL 282 Aircraft: ONB-07970 Pilot ID: KARSTEN ***** = Date: 04/04/2000 = -----</p>	
<p><i>Date</i></p>	<p>= Date: 04/04/2000 = -----</p>	<p><i>Flight 1</i></p>	<p><i>Header</i></p>	<p>Flight: 1 Start: 08:45:31 End: 08:48:33 Duration: 00:03:02 -----</p>
<p><i>Lift Detail</i></p>	<p>Lift: 1 5100 LB+ Start: 08:40:00A Turn Time: 00:00:39 Lift: 2 5100 LB+ Start: 08:40:39A Turn Time: 00:00:41 -- Flight 1 End-- -----</p>	<p><i>Lift Detail</i></p>	<p>Lift: 1 1250 LB+ Start: 08:45:58C Turn Time: 00:00:31 Lift: 2 1250 LB* Start: 08:46:29C Turn Time: 00:00:46 -- Flight 1 End-- -----</p>	
<p><i>Footer</i></p>	<p>-----</p>	<p><i>Footer</i></p>	<p>-----</p>	
<p><i>Flight 2</i></p>	<p>Flight 2 Start: 08:41:23 End: 08:43:52 Duration: 00:02:29 -----</p>	<p><i>Customer 2 Flight Summary</i></p>	<p>***** * Totals & Averages * ***** Flights: 1 T Flt Time: 00:03:02 A Flt Time: 00:03:02 Lifts: 2 T Weight: 2500LB A Weight: 1250LB T Trn Time: 00:01:17 A Trn Time: 00:00:38 =====</p>	
<p><i>Lift Detail</i></p>	<p>Lift: 3 5000 LB* Start: 08:41:38A Turn Time: 00:01:23 Lift: 4 4990 LB+ Start: 08:43:01A Turn Time: 00:00:51 -- Flight 2 End-- -----</p>	<p><i>Codes for the the minimum load and time settings used</i></p>	<p>Lift Minimum Codes A = 0300 LB 005 Sec B = 0500 LB 005 Sec C = 0500 LB 010 Sec * = Captured Lift + = Acc Corrected % = Averaged Lift =====</p>	
<p><i>Footer</i></p>	<p>-----</p>	<p><i>Report Footer</i></p>	<p>C-23 DATA RECORDER/PRINTER ONBOARD SYSTEMS Vancouver Washington</p>	

Figure 4-2 An example summary for Customer 1

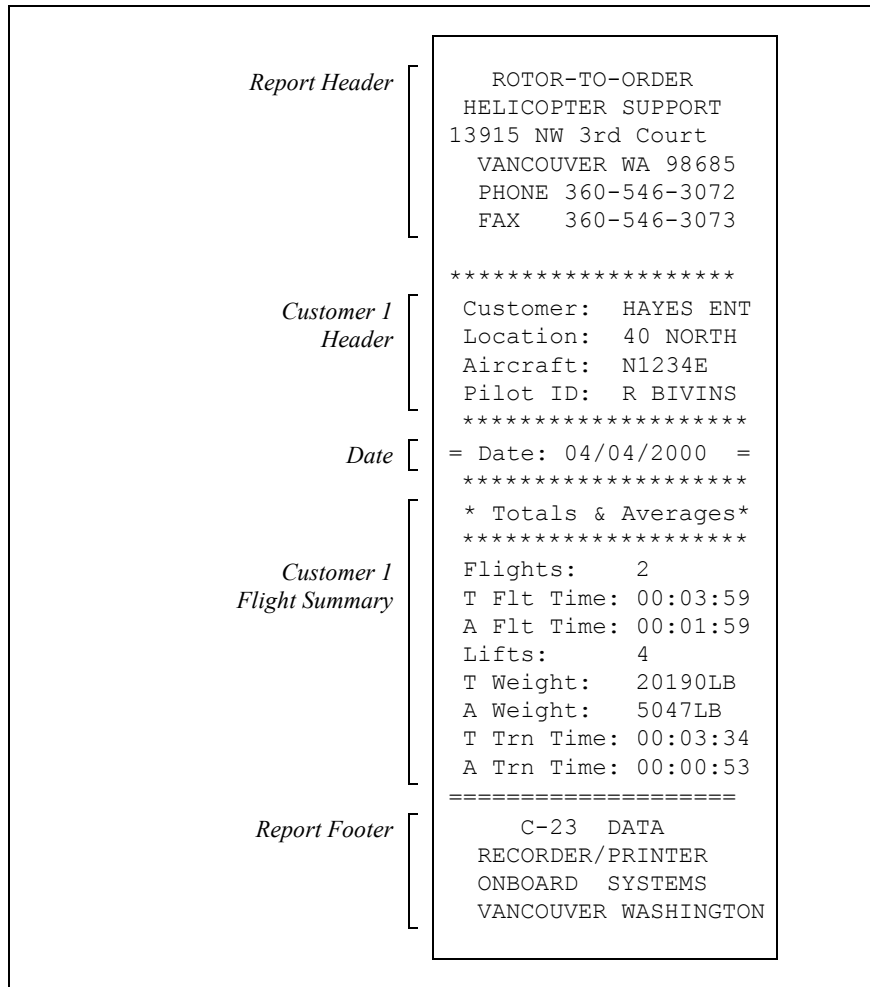

Table 4-2 Sections printed on a report or a summary

Report section	REPORT	SUMMARY
Report header	X	X
Date	X	X
Customer header	X	X
Flight information	X	
Flight summary	X	X
Codes for minimum settings	X	
Report footer	X	X

Section 5

Using the Data Card

The Data Card is used to retrieve data that is generated by the weighing system and the data recorder. This section describes the data card and its use. Here are the topics in this section.

- *Inserting the Data Card* shows how to insert the data card into the data recorder or data card reader.
- *Erasing the Data Card* describes how to erase information that is stored on the data card.
- *Memory Capacity of the Data Card* describes the type and amount of information that is stored on the data card.

Copying the System Memory with the Data Card

The data card is used to transfer the information contained in the data recorders internal memory to the office PC. The card should not be left in the data recorder when not transferring data. Transferring data to the data card does not erase the data recorders internal memory.

To insert the data card refer to Figure 5-1 and follow these steps.

1. Orient the card such that the card arrow is pointing towards the Data Card slot with the arrow on the key pad side, as illustrated in Figure 5-1. It is possible to put the card in backward (with the arrow opposite the key pad) but the system will not transfer data in this orientation.
2. Gently guide the card straight into the slot until it stops. Do not force the card.

When a Data Card is inserted into the C-30, the system checks to see if data is stored on the card. If there is, a message is displayed indicating that data is stored on the card. Press the ENTER key to overwrite or erase the data. A message will appear when it is safe to remove the card. The C-30's memory is not erased by this process. Each time the card is inserted the entire contents of the C-30 memory is transferred to the card.

Figure 5-1 Inserting the data card

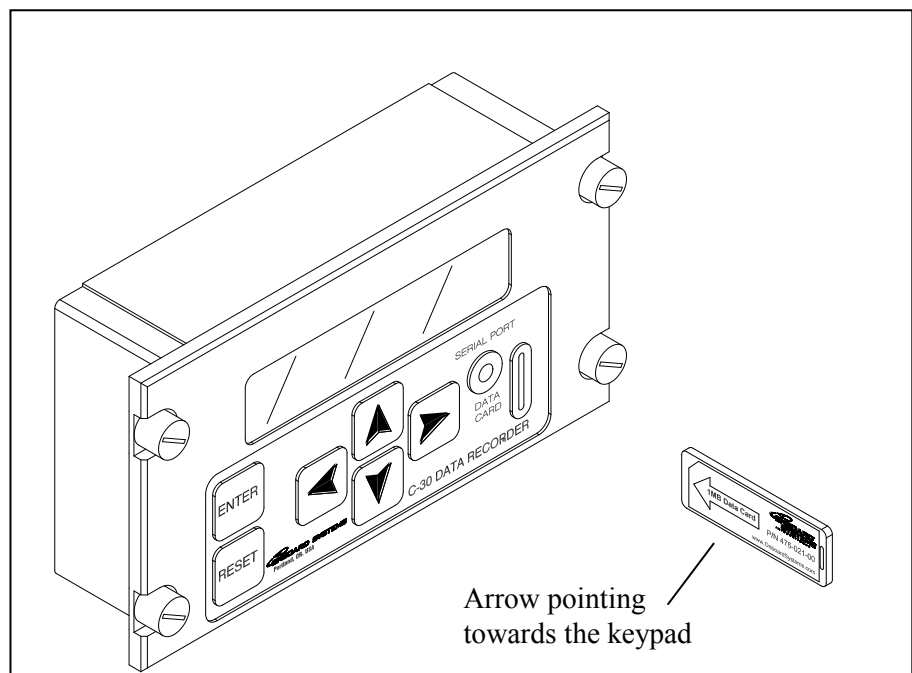

Memory Capacity of the Data Card

The Data card has a memory capacity of 1 MB. The card will store information for approximately 60,000 lifts.

This page intentionally left blank.

Section 6

Using the Optional Software

This section describes how to use the optional software.

Opening WinHook

Click on the WinHook icon to open the program, The screen should look like this:

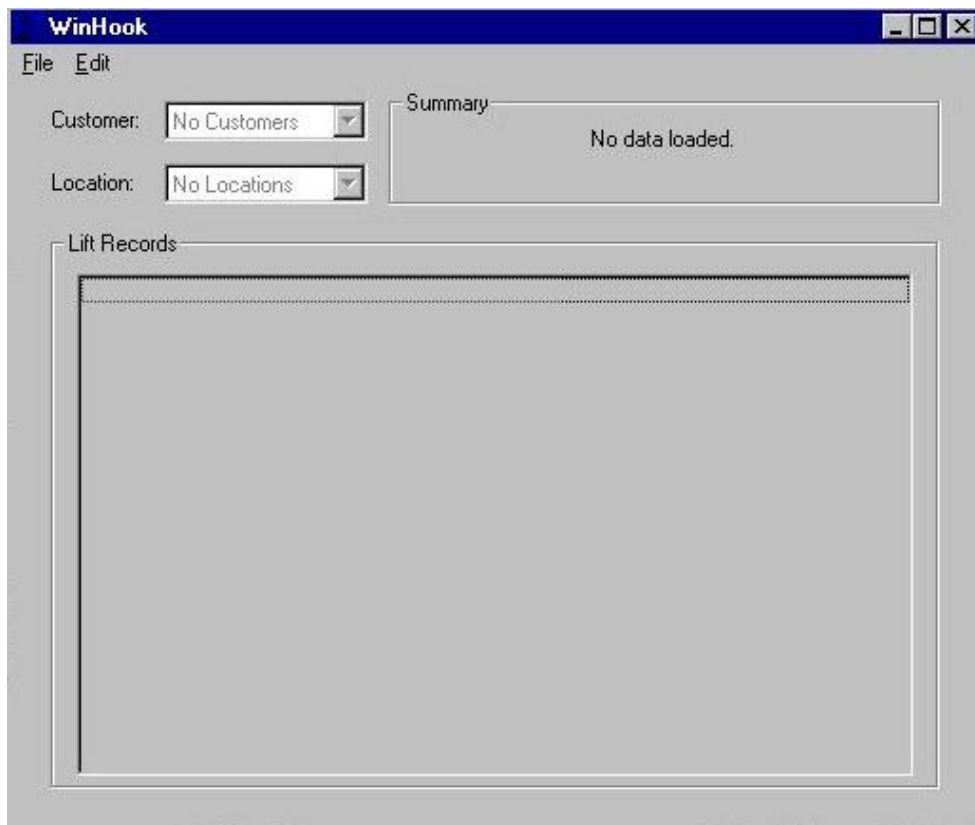

Retrieving Data

There are three ways to retrieve data. Data can be read from a Data Card, a serial port or opened from a previously saved file. Refer to *Downloading Data from a Data Card*, *Downloading Data from C-30 Serial Port* and *Opening a File* for explanations.

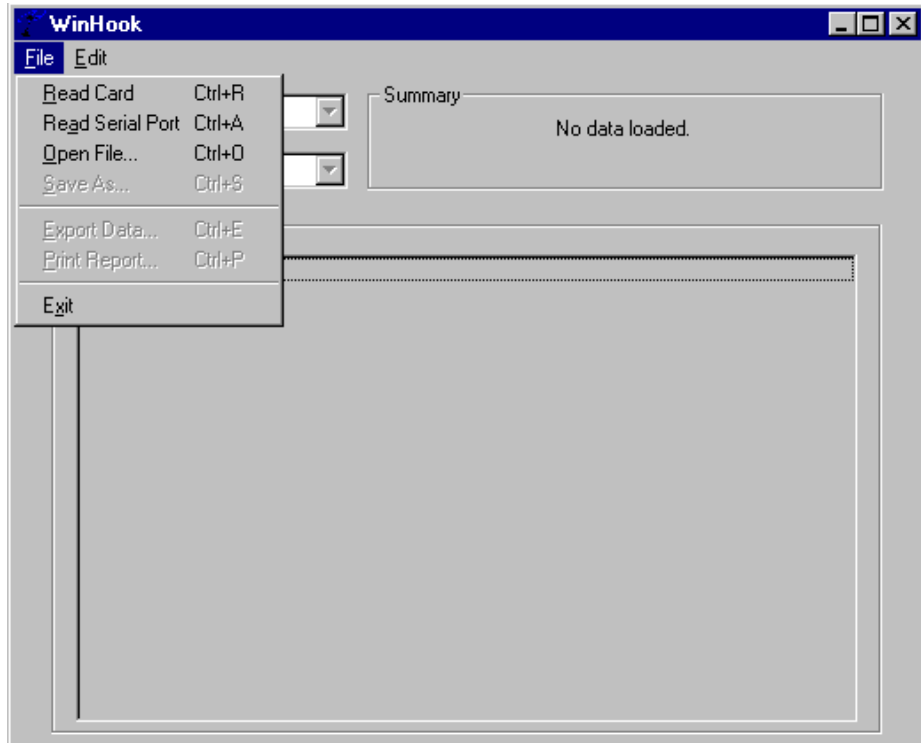

Downloading Data from a Data Card

Read Card from the File menu will allow you to download the information on the inserted data card.

1. Select Read Card from the File Menu

If there is a problem reading the data card, a window will appear that says: “No data card found. Please make sure the card is properly inserted.” Ensure that the data card reader is properly installed in the computer parallel port and that the data card is correctly installed in the card reader. Repeat Step 1.

2. The screen should look similar to this:

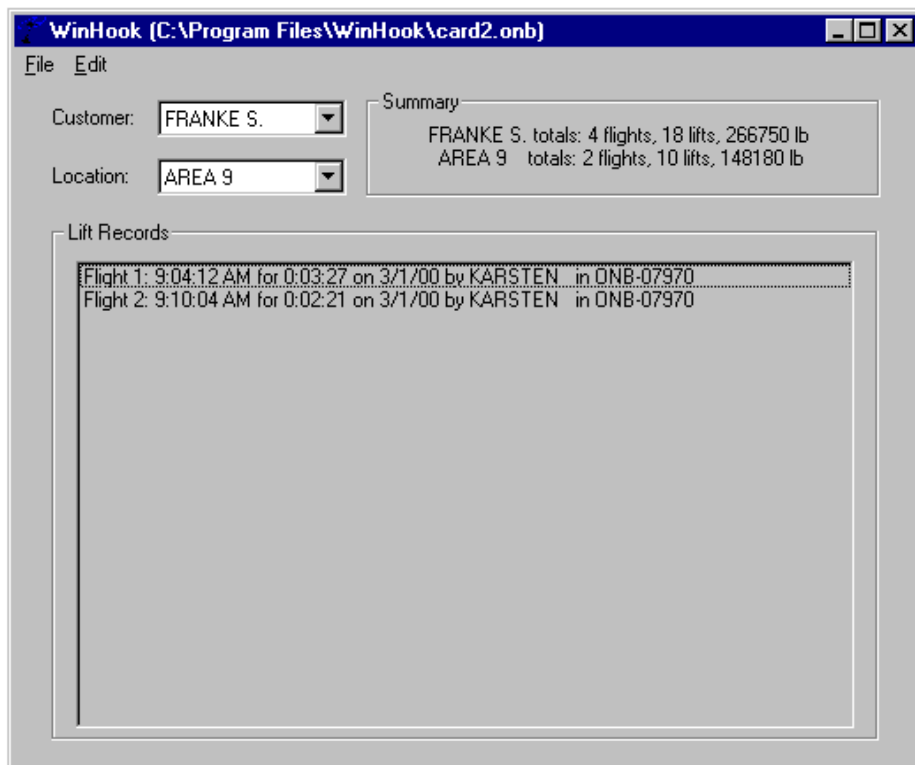

A summary box in the upper right hand corner displays summary information for a particular customer and location. In the upper left hand corner you can select different customers and different locations.

The bottom half of the screen displays the lift records for a particular customer and location. Double click a particular flight to view the individual lifts of the particular flight. Double click again to collapse the lift details.

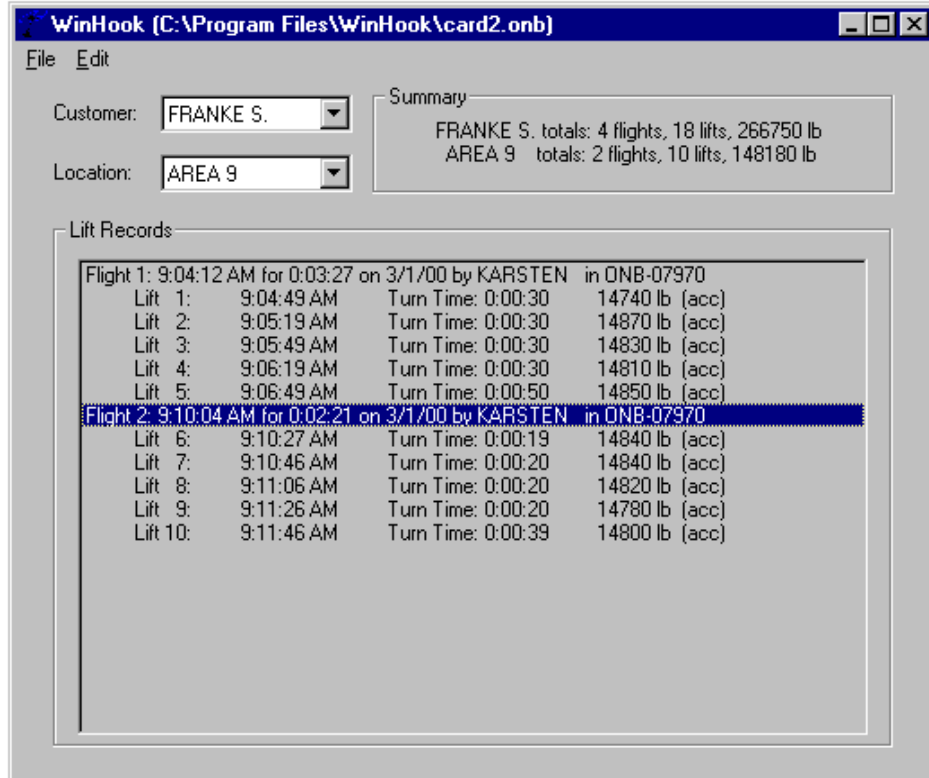

Downloading Data from C-30 Serial Port

C-30 data can be downloaded directly to a PC without using a data card. The download is completed by using a serial cable, P/N 270-099-00.

To download data from the C-30 Data Recorder to a PC, follow these steps.

1. Connect the C-30 Data Recorder to a PC by using serial cable, P/N 270-099-00.
2. Open WinHook program.
3. Select Options from the Edit menu. Select the applicable COM port.
4. Select Read Serial Port from the File menu.
5. The data will be displayed as soon as the download is complete.
6. Once the data is downloaded you can print, save or export the data as explained in this section.

NOTE

The C-30 Data Recorder cannot perform a download while flying, you must land in order to end the flight. Also, it is not possible to download data to a data card and to a PC via the serial port simultaneously.

Opening a File

Open File from the File menu will allow you to open any file with a .ONB extension.

1. Select Open File from the File Menu.
2. Choose a file with a .ONB extension

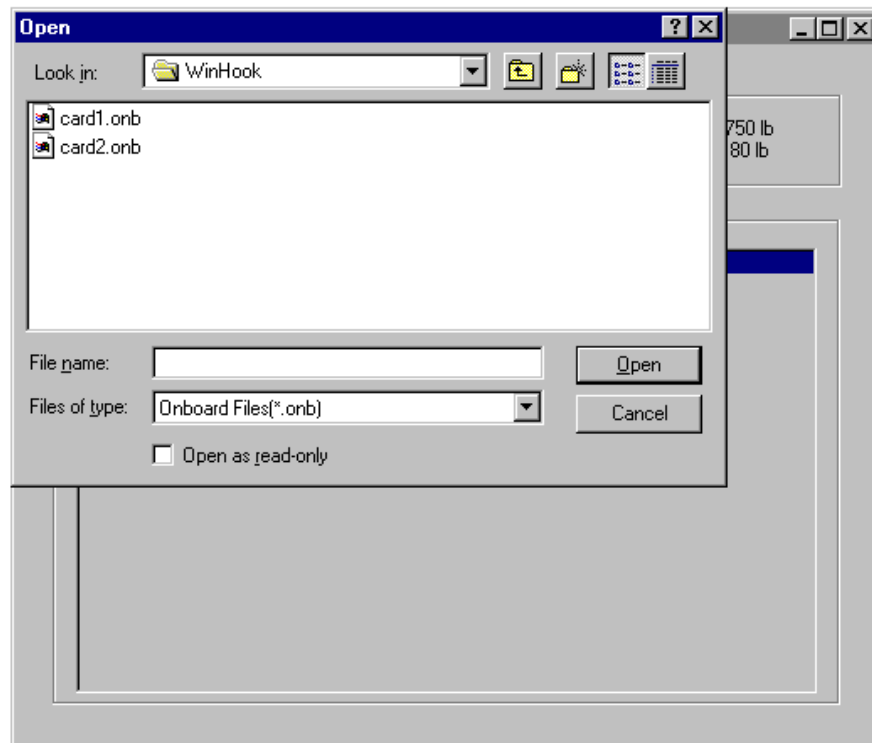

3. Click Open to open the file.

Saving Data

Save As from the File menu will allow you to save the file as a .ONB extension.

1. Select Save As from the File Menu.

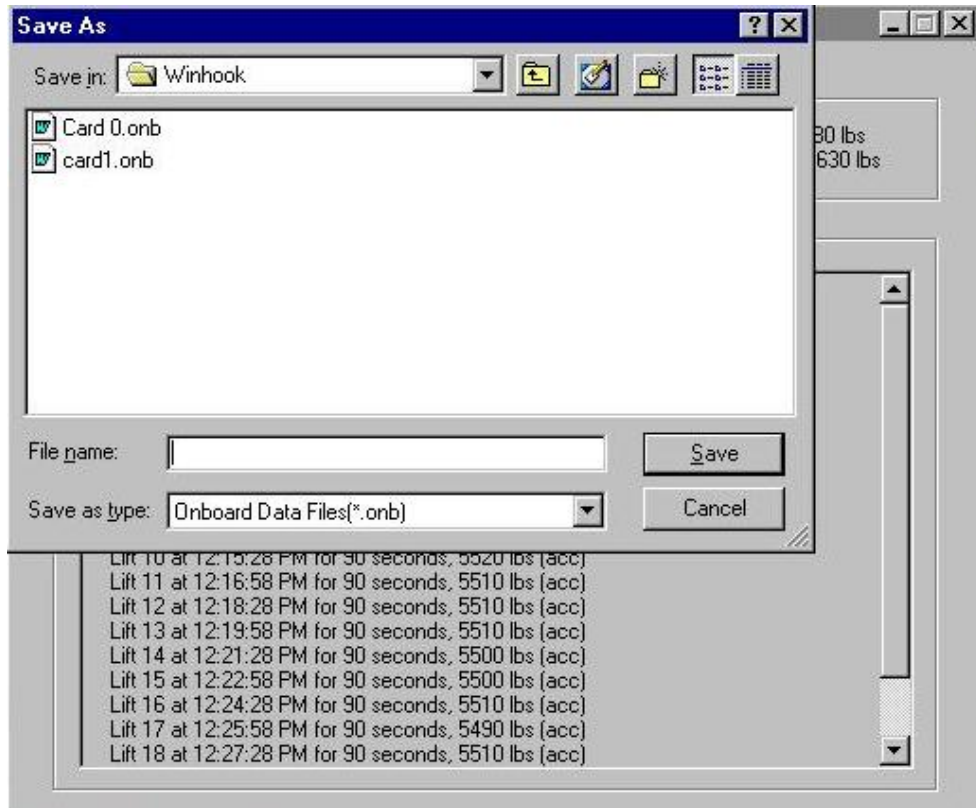

2. Select a location and name for the file.
3. Press okay to save and return to the main screen.

Exporting Data

Export Data from the File menu will allow you to save the data as a text file. This will allow you to open the data in a word processing or spreadsheet program. The data can be exported as a comma or tab delimited file.

1. Use the options menu to select a comma or tab delimited file. Refer to *Options* in this section.
2. Select Export Data from the File Menu.

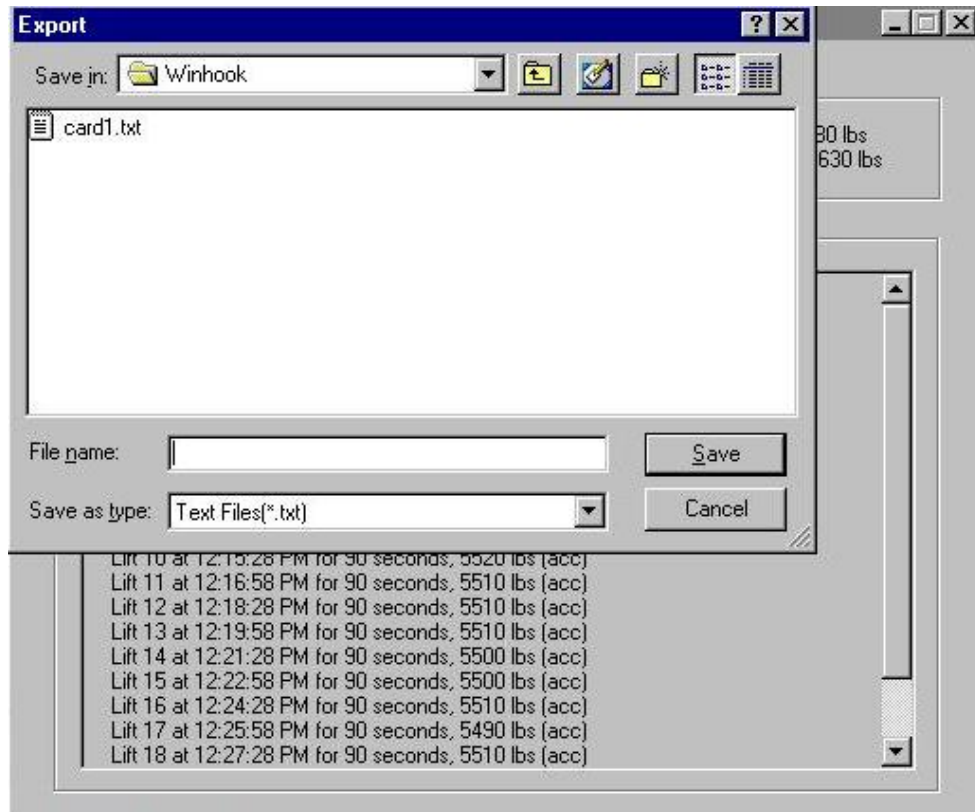

3. Select a location and name for the file.
4. Press okay to save and return to the main menu.

Printing a Report

Print Report from the File menu will allow you to print the data. You can print a particular customer and location or you can print all customers and locations. You can also print a summary or a detailed report.

1. Select Print Report from the File Menu.

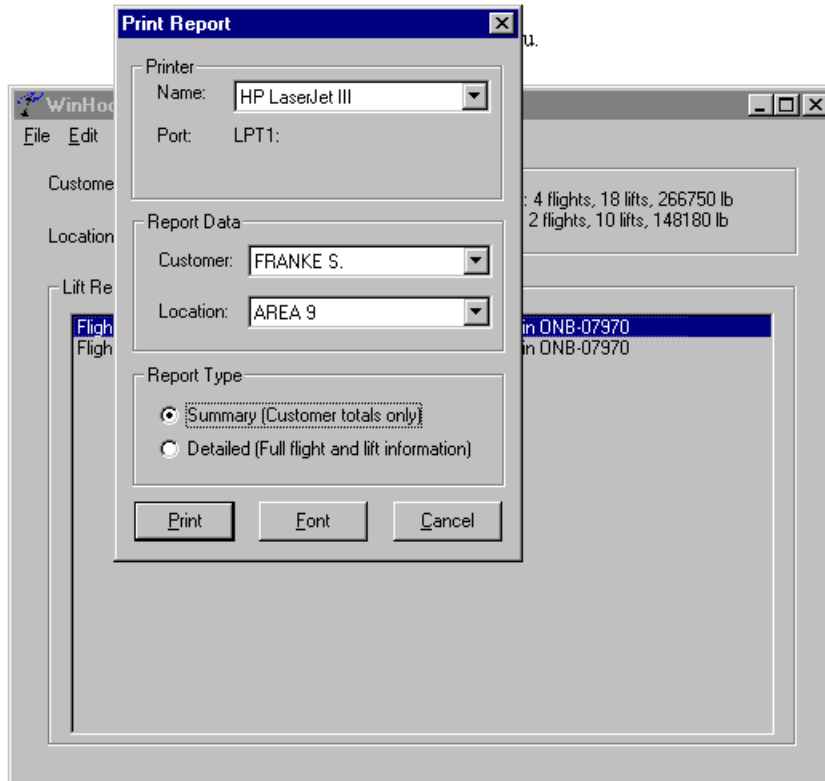

2. Select the desired print location.
3. Choose a particular customer or select all customers.
4. Choose a particular location or select all locations.
5. Select the report type, summary or detailed.
6. Select the report font and font size.

Figure 6-1 is an example of a detailed report.

Figure 6-1 Typical customer report

<p style="text-align: center;">HELICOPTER SUPPORT 1234 AIRPORT ROAD PORTLAND OR 97229 (503) 123-4567</p>								
Customer: J.APLSEED			Pilot: J. JENSEN					
Location: HILL 282			Aircraft: N12345678					
Flight	Date	Start	Duration	Lift	Load (lb)	Start Time	Turn Time	Notes
Date/Time Change: 03:24:2000 00:03:56								
1	03/24/2000	14:49:25	00:05:27					
				1	1020	14:49:42	00:00:30	(std) ¹
				2	1020	14:50:12	00:00:30	(avg) ¹
				3	1010	14:50:42	00:00:30	(std) ¹
				4	1010	14:51:12	00:00:30	(std) ¹
				5	1020	14:51:42	00:00:34	(std) ¹
				6	1020	14:52:16	00:00:26	(avg) ²
				7	1020	14:52:42	00:00:30	(std) ²
				8	1020	14:53:12	00:00:30	(std) ²
				9	1020	14:53:42	00:00:30	(std) ²
				10	1020	14:54:12	00:00:30	(cap) (std) ²
2	03/24/2000	15:07:16	00:06:10					
				11	1350	15:07:41	00:00:40	(std) ²
				12	1350	15:08:21	00:00:40	(std) ²
				13	1360	15:09:01	00:00:40	(std) ²
				14	1340	15:09:41	00:00:40	(std) ²
				15	1340	15:10:21	00:00:40	(std) ²
				16	1350	15:11:01	00:00:40	(avg) ²
				17	1350	15:11:41	00:00:40	(avg) ²
				18	1350	15:12:21	00:00:40	(std) ²
Date/Time Change: 03:24:2000 17:56:59								
Total Flights:		2		Total Lifts:		18		
Total Flight Time:		00:11:37		Total Lift Time:		00:10:20		
Average Flight Time:		00:05:48		Average Lift Time:		00:00:34		
Average Weight (lb):		1,090		Total Weight (lb):		19,620		
Lift recognition thresholds:								
				¹	400 lb	15 seconds		
				²	400 lb	5 seconds		
								05/29/2000: Page 1
								WinHook (C:\Program Files\WinHook\Cascade Cedar.onb)

Reading a Report

The System uses the following rules to structure a report.

- If the customer, location, pilot, date or aircraft ID changes, a banner line is printed showing the change, and the lift count and summary data is restarted.
- The notes column next to each lift shows the method used to record the lift and the lift minimums. See the section *How Lifts Are Recorded* for an explanation of the items in parentheses.

Editing the Report Header

Report header from the Edit menu will allow you to change the heading on your reports.

1. Select Header from the Edit Menu
2. A window with your own heading that was previously entered in the data recorder will be displayed:

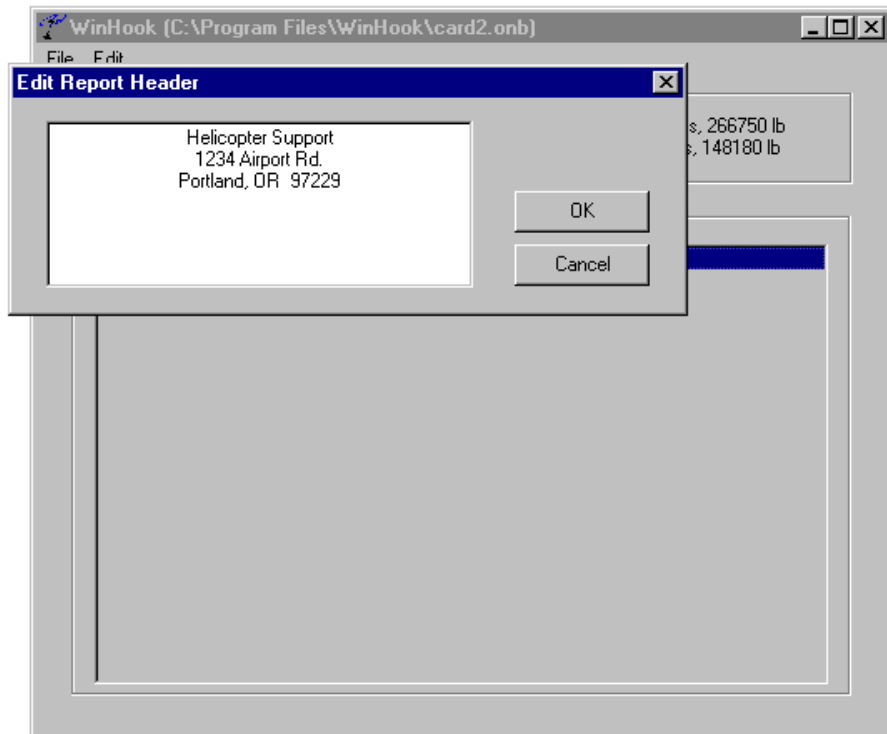

3. Edit the header.
4. Press okay to save and return to the main screen.

NOTE

This procedure does not change the data on the data card. It only changes the way files are saved or printed.

Options

Options from the Edit menu will allow you to set Export File delimiter options, Lift Record Display and COM Port options.

1. Select Options from the Edit Menu

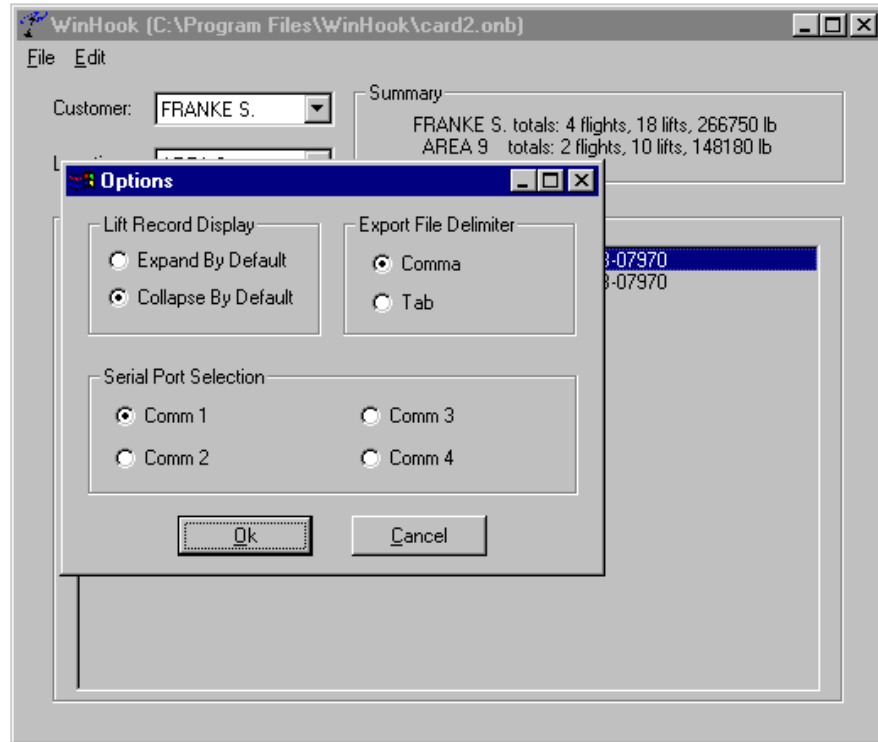

2. Choose whether you would like to export files delimited by a comma or a tab.
3. Choose whether you would like lift records expanded or collapsed by default. This applies when a file is saved and later opened again. If you select expanded lifts, the lifts will be automatically shown in the main screen. If you select collapsed lifts, the lifts will not be shown and in order to view them you will have to double click on the flight.
4. Select the appropriate COM Port.
5. Press okay to save and return to the main screen.

This page intentionally left blank.

Section 7

Maintaining the System

This section describes the maintenance procedures you should observe to obtain maximum life and accuracy from the data card system. It also includes some trouble-shooting hints should problems occur with the system.

Data Recorder Care

The data recorder does not require periodic maintenance.

Follow these guidelines in caring for the data recorder.

- Keep the data recorder dry to extend its useful life. During wet weather, remove the unit from the aircraft, or cover it to reduce the possibility of water absorption.

NOTE

Do not open the data recorder. Opening the data recorder voids its warranty. There are no user replaceable parts in the data recorder.

Cable and Connector Maintenance

Follow these guidelines for cable and connector maintenance.

- Check cables and connectors periodically for signs of wear. Replace cables that have worn through the foil shield.
- Attempt to identify and correct the causes of cable wear including bending, shearing, and chafing.
- Cover and protect the connectors when not in use to prevent corrosion and mechanical damage to the pins.

Troubleshooting

This topic lists problems you may encounter when using the Data Card System, and describes possible solutions.

Problem	Corrective Action
<p>Power is on but the data recorder display does not show a readout. The unit appears to be dead.</p>	<ol style="list-style-type: none"> 1. Check the fuse or circuit breaker between the positive battery wire and the data recorder. Replace the fuse if it is faulty. 2. Check the entire power cable for damage, corrosion or a faulty connection. Clean or replace wiring if problems are found. 3. Reset the contrast settings as the contrast may be set to light to see. After power-up wait at least 1 minute. Then enter the following key sequence: <ul style="list-style-type: none"> • Press down arrow + up arrow together (1) one time • Press up arrow (3) three times • Press “Enter” (1) one time • Press down arrow (1) one time • Press “Enter” (1) one time • Press “Reset” (1) one time. After this step, the bottom bar of the screen should be half filled with boxes. • Press “Enter” (1) time 4. If there is no response to these solutions, refer to the <i>Appendix</i> for instructions for returning the unit to the factory.
<p>Numbers appear on the display but they do not change with weight or when a key is pressed.</p>	<p>This problem is caused by a momentary burst or lapse of electrical power, causing a break in the flow of the program in the data recorder.</p> <ol style="list-style-type: none"> 1. The problem can usually be reversed by shutting off the data recorder power for several seconds. 2. As a long term solution, ensure that all electrical wiring is secure and free of corrosion, and install an electrical filter.

Troubleshooting, continued

This topic lists problems you may encounter when using the WinHook software program, and describes possible solutions.

Problem	Corrective Action
You receive the message, “No Data card was found. Please make sure the card is properly seated.”	Check the card reader’s connection to the parallel port. Check to make sure the data card is properly seated. Replace batteries. See Replacing your Data Card Reader’s Batteries.
You receive the message, “Error parsing data stream: multiple setup sectors”	Defective data is on the card. Complete the following steps in order, checking to see if the error still exists after each step, until you no longer receive error. <ol style="list-style-type: none"><li data-bbox="609 730 889 762">1. Down load new data.<li data-bbox="609 772 862 804">2. Reformat memory.<li data-bbox="609 814 857 846">3. Re-initialize C-30.
You receive the message, “Warning: No setup data was found”	1. Serial cable is damaged or wired incorrectly. Contact Onboard Systems.

This page intentionally left blank.

Section 8

Installation Authorization

The Data Card System installation is authorized by the Federal Aviation Administration (FAA) for use with all Onboard Systems Electronic Load Weigh Systems.

FAA Letter of Authorization



U.S. Department
of Transportation
**Federal Aviation
Administration**

**Transport Airplane Directorate
Aircraft Certification Service**

1601 Lind Avenue S.W.
Renton, Washington 98055-4056

March 22, 1990

Onboard Systems
11212 NW St. Helens Rd.
Portland, OR 97231

Gentlemen:

This is in response to your letter dated March 15, 1990, concerning the disposition of your proposed helicopter cargo hook Data Logger System. From your letter, we understand that your Data Logger will provide a continuous record of the load (weight) carried on a cargo hook, when connected to the output plug predestined into your helicopter electronic cargo hook load system display units, previously approved by our office.

We agree with your position that a portable Data Logger System such as that defined in your letter will not adversely impact aircraft safety. Accordingly, we do not deem it necessary that you obtain formal FAA approval for the manufacture and sale of your unit.

If we may be of further assistance, please do not hesitate to contact us.

Sincerely,

Original Signed by
David G. Hmeil

David G. Hmeil
Manager, Aircraft Modification Branch
Seattle Aircraft Certification Office

This page intentionally left blank.

Appendix

This appendix contains the following information for the Data Card System.

- Specifications
- Ordering information
- Limited warranty
- Return instructions

Specifications

The tables in this section give the specifications for the data card system components and optional equipment.

Physical Specifications

Table A-1 shows the physical specifications for the data card system components.

Table A-1 Physical specifications

Component	Height	Width	Depth	Weight
C-30 Data Recorder	3.1 in	5.75 in	1.55 in	1.0 lb
	7.9 cm	14.6 cm	3.9 cm	454 g
C-23 Printer	2.0 in	4.0 in	4.5 in	12 oz
	5.1 cm	10.2 cm	11.4 cm	340 g
Data Card	0.6 in	1.78 in	0.07 in	0.1 oz
	1.5 cm	4.5 cm	1.8 mm	2.8 g
Data Card Reader	0.75 in	2.30 in	2.25 in	1.5 oz
	1.9 cm	5.8 cm	5.7 cm	43 g

Electrical Specifications

Table A-2 shows the electrical specifications for the data recorder and the optional printer.

Table A-2 Data recorder electrical specifications

Characteristic	Specification
Operating voltage	18 – 30 Vdc
Current consumption	
C-30 Data Recorder	250 mA
C-23 Printer	1.5 A continuous, 5 A start up
Storage temperature	-40° – 158°F (-40° – 70°C)
Operating temperature	
C-30 Data Recorder	-5° - 158°F (-20° - 70°C)
C-23 Printer	41° - 104°F (5° - 40°C)

Tables A-3, A-4 and A-5 show the connector pinouts of the Data Recorder and the Load Weigh System components.

Table A-3 Data Recorder Pin Out

Connector to Internal Harness		
Pin	Color	Function
1	Black	Ground
2	Blue	Capture SW
3	Red	Power
4	Brown	Flight SW
5	Shield	Shield
7	Green	Clock
9	White	Data

Connector to C-23 Printer		
Pin	Color	Function
1	Black	Ground, Aircraft
2	Blue	+5V
4	Red	+28V, Aircraft
5	Shield	Shield
6	White	RxD
8	Green	TxD
9	Brown	Ground, C-30

Table A-4 C-39 Indicator Pin Out

Pin Letter	Function
A	+ 28 VDC In
B	- Load Cell Signal
C	+ Load Cell Signal
D	+ Load Cell Excitation
E	Load Cell Common
F	Analog Out Common
G	+ Analog Out
H	Hook Open
J	Data Recorder Clock
K	Data Recorder Data
L	Shield
M	Back Light Common
N	Back Light Source 28 VDC
P	Aircraft Ground
R	Not Used

Table A-5 Load Cell Pin Out

Pin Letter	Wire Color
A	Red
B	Green
C	White
D	Black
E	Shield

Ordering Information

Order additional data card system components, accessories, and supplies by quantity and the part number shown in Table A-6. All items can be ordered separately.

Table A-6 Ordering information

Description		Part number
Hardware components	C-30 Data Recorder	210-189-00
	C-23 Printer	210-100-00
	Data Card	475-021-00
	Data Card Reader	210-195-00
Software components	Software, IBM PC and 100%-compatibles	100-050-00
Accessories	Data Card System Owner's Manual	120-089-00
	Capture switch wire	270-019-00
	Flight-time switch wire	270-022-00
	Serial Cable	270-099-00
Supplies	Roll paper for C-23 Printer	215-051-00
	Cartridge ribbon for C-23 Printer	212-006-00

Limited Warranty

ONBOARD SYSTEMS Data Card System components are warranted to be free from defects in workmanship and materials for a period of one year from the date of purchase. The components are warranted to function as intended when properly installed and used for their intended purpose. Parts which prove to be defective are repaired or replaced free of charge FOB factory at the manufacturer's option if the following conditions have been met.

- No repairs have been attempted by other than Onboard Systems personnel.
- The system or component is returned properly packaged, insured, with transportation charges prepaid.
- After examination, Onboard Systems personnel are satisfied that the defects were not caused by abuse, and that the components were not subjected to conditions that violate system specifications.

The following are specifically excluded from this warranty.

- Software
- Cables

This warranty covers only the original purchaser. In no event shall Onboard Systems be liable for indirect, special, incidental or consequential damage resulting from the use of this product, even if Onboard Systems has been advised of the possibility of such damage. Each user must satisfy himself that the system is suited to his needs and is performing according to his requirements.

Instructions for Returning Equipment to the Factory

If an Onboard Systems product must be returned to the factory for any reason (including returns, service, repairs, overhaul, etc) obtain an RMA number before shipping your return.



An RMA number is required for all equipment returns.

- To obtain an RMA, please use one of the listed methods.
 - Contact Technical Support by phone or e-mail (Techhelp@OnboardSystems.com).
 - Generate an RMA number at our website: <http://www.onboardsystems.com/rma.php>
- After you have obtained the RMA number, please be sure to:
 - Package the component carefully to ensure safe transit.
 - Write the RMA number on the outside of the box or on the mailing label.
 - Include the RMA number and reason for the return on your purchase or work order.
 - Include your name, address, phone and fax number and email (as applicable).
 - Return the components freight, cartage, insurance and customs prepaid to:

Onboard Systems
13915 NW 3rd Court
Vancouver, Washington 98685
USA
Phone: 360-546-3072