

**PLEASE CHECK WEB SITE AT [WWW.ONBOARDSYSTEMS.COM](http://WWW.ONBOARDSYSTEMS.COM) FOR  
THE LATEST REVISION OF THIS MANUAL**

**Cargo Hook  
Suspension System  
For the  
Bell 206L & 407 Series With  
Talon LC Keeperless  
Cargo Hook**

**System Part Numbers  
200-258-00, W/O Load Weigh  
200-259-00, W/ Load Weigh  
200-259-01, W/Load Weigh and 5V Lighting**

*Owner's Manual Number 120-092-00  
Revision 12  
03/12/15*



13915 NW 3<sup>rd</sup> Court Vancouver Washington 98685 USA  
Phone: 360-546-3072 Fax: 360-546-3073 Toll Free: 800-275-0883  
[www.OnboardSystems.com](http://www.OnboardSystems.com)

This page intentionally left blank.

## Record of Revisions

<i>Revision</i>	<i>Date</i>	<i>Page(s)</i>	<i>Reason for Revision</i>
4	04/28/06	2-7	Added electrical connection caution statement.
5	09/07/06	1-2, 2-11, 2-12,	Updated manual to allow the installation of wire harness 270-048-04.
6	04/16/07	Section 1, 2-2, 2-7, 2-10, 2-12, 3-9 & 3-1 Section 4	Changed P/N 232-030-01 to 232-030-02 (per Service Bulletin 159-020-00). Updated warnings, cautions and notes to current format.
7	07/10/08	1-3, 2-1, 2-6, 2-7	Added kit P/N 200-245-00 to BOM, added note regarding forward pair of pillow block fasteners, updated torque instructions for nut 510-170-00, and clarified release cable rigging dimension.
8	09/15/08	1-1, 2-1	Added P/Ns 206-706-341-117, -123, and -125 as compatible Bell provisions kits. Clarified Figure 2-1 and corresponding instructions.
9	08/11/09	1-3, 2-7	Added caution note and revised figure 2-7. Changed P/N 268-004-00 to 268-004-01 for improved service life.
10	12/18/09	2-11 to 2-14	Updated manual to reflect new load weigh harness configuration. Updated EMI note in installation check-out section.
11	12/22/09	1-1	Added P/N 200-328-00 as an eligible fixed provisions kit for the 407 model.
12	03/12/15	Section 1, 2-1, 2-2, 2-7, 2-8, 2-10, 2- 11, 2-13, 2-14, 3- 8, 3-9, 3-12, 4-1, 4-3, 5-1	Updated safety labels to ANSI format throughout, added load cell P/N 210-179-01, updated cargo hook load rigging section.

### Register Your Products for Automatic Notifications

Onboard Systems offers a free notification service via fax or email for product alerts and documentation updates. By registering your Onboard Systems products at our website, we will be able to contact you if a service bulletin is issued, or if the documentation is updated.

You can choose to receive notices on an immediate, weekly, or monthly schedule via fax, email or both methods. There is no charge for this service. Please visit our website at [www.onboardsystems.com/notify.php](http://www.onboardsystems.com/notify.php) to get started.

This page intentionally left blank.

# ***CONTENTS***

## ***Section 1*** **General Information**

- Introduction, 1-1
- Safety Labels, 1-2
- Specifications, 1-3
- Inspection, 1-3
- Bill of Materials, 1-4
- Theory of Operation, 1-5

## ***Section 2*** **Installation Instructions**

- Cargo Hook Suspension System Removal, 2-1
- Cargo Hook Suspension System Installation, 2-1
- Load Weigh System Installation, 2-11
- Internal Harness Installation, 2-11
- C-39 Cockpit Indicator Installation, 2-11
- Indicator Internal Back Light, 2-11
- Indicator Hook-Open Warning, 2-12
- Remote Analog Meter, 2-12
- Electrical Connections, 2-12
- Installation Check-Out, 2-13
- Component Weights, 2-13
- Suspension System Location, 2-14
- Paper Work, 2-14

## ***Section 3*** **Load Weigh Systems Operation Instructions**

- Indicator Front Panel, 3-1
- The Run Mode, 3-2
  - To Zero or Tare the Display, 3-3
  - To Un-Zero the Display, 3-3
  - Error Codes, 3-4
- The Setup Mode, 3-5
  - Indicator Dampening, 3-7
    - To look at, or change the dampening level, 3-7
  - Indicator Calibration, 3-7
    - To look at or change the calibration code, 3-8
  - Installation Zero, 3-9
    - To run the installation zero routine, 3-9
  - Calibration by Lifting a Known Weight, 3-9
    - To run calibration by known weight routine, 3-10
  - Setting the Scale on a Remote Analog Meter, 3-11
    - To look at or change the scale, 3-11
  - Select KG or LB Units, 3-12
    - To look at or change the units, 3-12
  - Indicator Version, 3-13

# ***CONTENTS, continued***

## ***Section 4* Cargo Hook Suspension System Operation Instructions**

Operating Procedures, 4-1

Cargo Hook Loading, 4-2

Cargo Hook Rigging, 4-3

## ***Section 5* Maintenance**

Instructions for Returning a System to the Factory, 5-1

## ***Section 6* Certification**

FAA STC, 6-1

Canadian Approval, 6-2

EASA Approval, 6-3

Brazilian Approvals, 6-5

# *Section 1*

## **General Information**

### **Introduction**

The 200-258-00, 200-259-00 and 200-259-01 Cargo Hook Suspension Systems are approved for installation on the following Bell helicopters:

Model	Serial Numbers
206L	45001-45153
206L-1	45154 and on
206L-3	51001 and on
206L-4	52001 and on
407	All

The system replaces the Bell kit part numbers 206-706-341-101, -105, and -109 Auxiliary Equipment Kit - Cargo Hook. It must be installed with the Bell part number 206-706-341-7, -9, -103, -111, -113, -117, -123, or -125 Auxiliary Equipment Kit- Cargo Hook Provisions or Onboard Systems P/N 200-328-00 Fixed Provisions Kit. The 200-328-00 fixed provisions kit is approved for the 407 model under Onboard Systems STC SR01943SE.

## Safety Labels

The following definitions apply to safety labels used in this manual.



Indicates a hazardous situation which, if not avoided, will result in death or serious injury.



Indicates a hazardous situation which, if not avoided, could result in death or serious injury.



Indicates a hazardous situation which, if not avoided, could result in minor or moderate injury.



Draws the reader's attention to important or unusual information not directly related to safety.



Used to address practices not related to personal injury.



# Specifications

**Table 1-1 Suspension System Specifications**

Design load	3,000 lb. (1360 kg.)
Design ultimate strength	13,500 lb. (6120 kg.)
Unit weight P/N 200-258-00	12 pounds (5.44 kg.)
Unit weight P/N 200-259-00	13 pounds (5.90 kg.)

**Table 1-2 P/N 528-023-01 Cargo Hook Specifications**

Design load	3,500 lb. (1,588 kg.)
Design ultimate strength	13,125 lb. (5,953 kg.)
Electrical release capacity	8,750 lb. (3,969 kg.)
Mechanical release capacity	8,750 lb. (3,969 kg.)
Force required for mechanical release at 3,500 lb.	8 lb. Max. (.600" travel)
Electrical requirements	22-32 VDC 6.9 – 10 amps
Minimum release load	0 pounds
Unit weight	3.0 pounds (1.35 kg.)
Mating electrical connector	PC06A8-2S SR

## Inspection

Inspect the kit items for evidence of damage, corrosion and security of lock wire and fasteners. If damage is evident, do not use the items until they are repaired.

## Bill of Materials

The following items are included with the Suspension System, if shortages are found contact the company from whom the system was purchased. The Bell Helicopter provisions kit is required to complete the installation.

Part No.	Description	200-258-00 Quantity	200-259-00 Quantity	200-259-01 Quantity	200-245-00 Quantity**
210-167-00	Beam Assembly w/o Load Cell	1	-	-	-
210-178-00	Beam Assembly with Load Cell	-	1	1	-
210-179-01***	E-85 Load Cell Assembly	-	-	-	1
268-004-01	Manual Release Cable	1	1	1	-
270-074-00	Electrical Release Cable	1	1	1	-
528-023-01	3,500 Lb. Cargo Hook	1	1	1	-
290-331-00	Release Fitting	1	1	1	-
510-229-00	Bolt	2	2	2	-
510-095-00	Washer	2	2	2	-
510-102-00	Nut	2	2	2	-
290-370-00	Trunnion Pin	2	2	2	-
290-374-00	Thrust Spacer	10	10	10	-
510-234-00	Nut	4	4	4	-
510-235-00	Bolt	4	4	4	-
510-114-00	Nut	2	2	2	-
510-100-00	Washer	2	2	2	-
510-230-00	Bolt	2	2	2	-
232-030-02	Pillow Block Assembly	2	2	2	-
600-006-00	Release Cable Disconnect	1	1	1	-
210-095-00	C-39 Indicator	-	1	-	1
210-177-00	C-39 Indicator, 5V Lighting	-	-	1	-
270-048-04	Harness Assembly	-	1	1	1
400-048-00	Power Switch	-	1	1	1
215-010-00	Placard	-	2	2	1
215-012-00	Placard	-	1	1	1
512-001-00	Ty-Wrap	-	10	10	10
510-028-00	Screw	-	6	6	6
510-029-00	Nut	-	6	6	6
510-062-00	Washer	-	8	8	8
235-035-00	QD Bracket	-	1	1	1
120-092-00	Owner's Manual	1	1	1	1
121-003-00	RFM Supplement	1	1	1	-
122-005-00	Cargo Hook Service Manual	1	1	1	-
123-007-00	ICA Maintenance Manual	1	1	1	-

\* The 210-177-00 Indicator is equipped with a 5 Volt back lighting system. It is an optional indicator that can be ordered in place of the 210-095-00 Indicator.

\*\* P/N 200-245-00 is a load weigh kit that can be purchased separately to upgrade the 200-258-00 kit to a 200-259-00 kit.

\*\*\* P/N 210-179-01 supersedes P/N 210-179-00. These assemblies are interchangeable.

## Theory of Operation

The primary elements of the Cargo Hook are the load beam, the internal mechanism, and a DC solenoid. The load beam supports the load and is latched through the internal mechanism. The DC solenoid, an external manual release cable and a manual release lever provide the means for unlatching the load beam.

The load is attached to the load beam by passing the cargo sling ring into the throat of the load beam and pushing the ring against the upper portion of the load beam throat, which will initiate the hook to close. In the closed position, a latch engages the load beam and latches it in this position.

To release the load, the latch is disengaged from the load beam. With the latch disengaged, the weight of the load causes the load beam to swing to its open position, and the cargo sling slides off the load beam. The load beam then remains in the open position awaiting the next load.

A load release can be initiated by three different methods. Normal release is achieved by pilot actuation of the push-button switch in the cockpit. When the push-button switch is pressed, it energizes the DC solenoid in the Cargo Hook, and the solenoid opens the latch in the internal mechanism. In an emergency, release can be achieved by operating a mechanical release cable. The release cable operates the internal mechanism of the Cargo Hook to unlatch the load beam. The load can also be released by the actuation of a lever located on the side of the Cargo Hook

This page intentionally left blank.

# Section 2

## Installation Instructions

These procedures are provided for the benefit of experienced aircraft maintenance facilities capable of carrying out the procedures. They must not be attempted by those lacking the necessary expertise.

### Cargo Hook Suspension System Installation

If installing the cargo hook suspension system on a helicopter that has a Bell P/N 206-706-341-125 Fixed Provisions Kit installed, the pillow blocks included with this kit must be removed. Retain the forward pairs of screws and nuts for each pillow block (the aft pairs of fasteners will not be re-used).



*The cargo hook suspension systems must be installed with the supplied 232-030-02 Pillow Blocks. These systems are not compatible with Pillow Blocks supplied by Bell.*

Attach the two P/N 232-030-02 Pillow Block Assemblies as illustrated below. Use sealant on the faying surfaces. At the forward pair of holes at each pillow block, re-use the screws and washers provided with the Bell Helicopter provisions kit. At the aft pairs of fasteners at each pillow block torque the 510-234-00 nuts and 510-235-00 bolts to 100-130 in-lbs.



*The 232-030-02 Pillow Blocks install exactly as the Bell pillow blocks with the exception of the P/N 510-235-00 bolts. These bolts are a shorter grip length than those used with the Bell pillow blocks and they are installed with the heads down to give clearance for the beam when it rotates.*

**Figure 2-1 Pillow Block Installation**

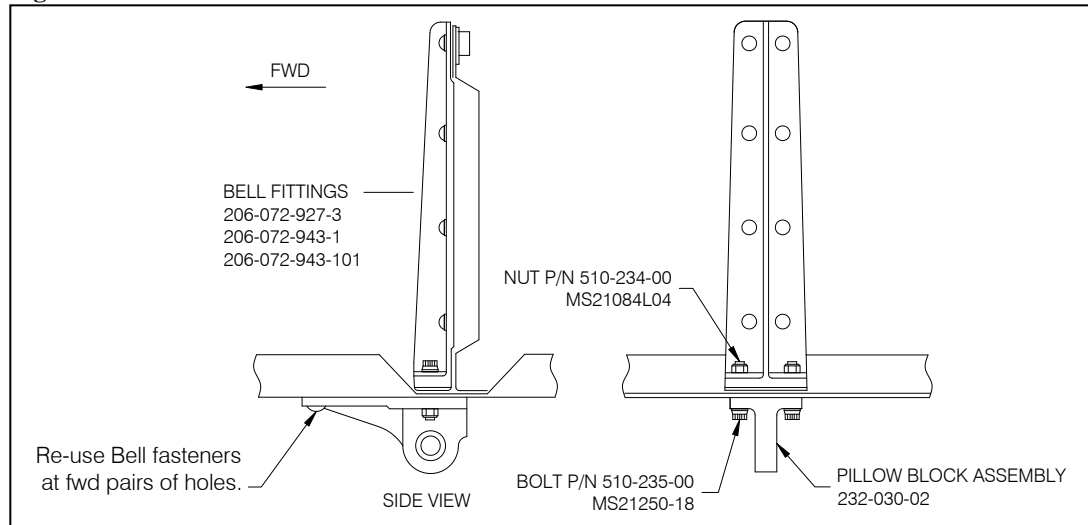

## Cargo Hook Suspension System Installation, continued

Attach the Beam Assembly, P/N 210-167-00 or 210-178-00, to the Pillow Blocks as illustrated.

# NOTICE

*The long end of the Carriage must point to the left side of the aircraft as illustrated below.*

Position the Thrust Spacers, P/N 290-374-00, on both sides of the Pillow Blocks to center the Beam Assembly between the Pillow Blocks and allow .000/.060 lateral movement of the beam assembly. The thrust spacers must be positioned on both sides of the pillow block so that when a lateral load is applied, the beam will not rub directly (metal to metal) against the pillow block. In addition to the above, the thrust spacers must be positioned so that when a lateral load is applied it will be distributed to both pillow blocks. To check this, apply approximately 10 pounds to the beam in the lateral direction. There should be a maximum of .060 gap when measured as shown in the Figures 2-3 and 2-4.

**Figure 2-2 Cargo Hook Suspension Assembly Installation**

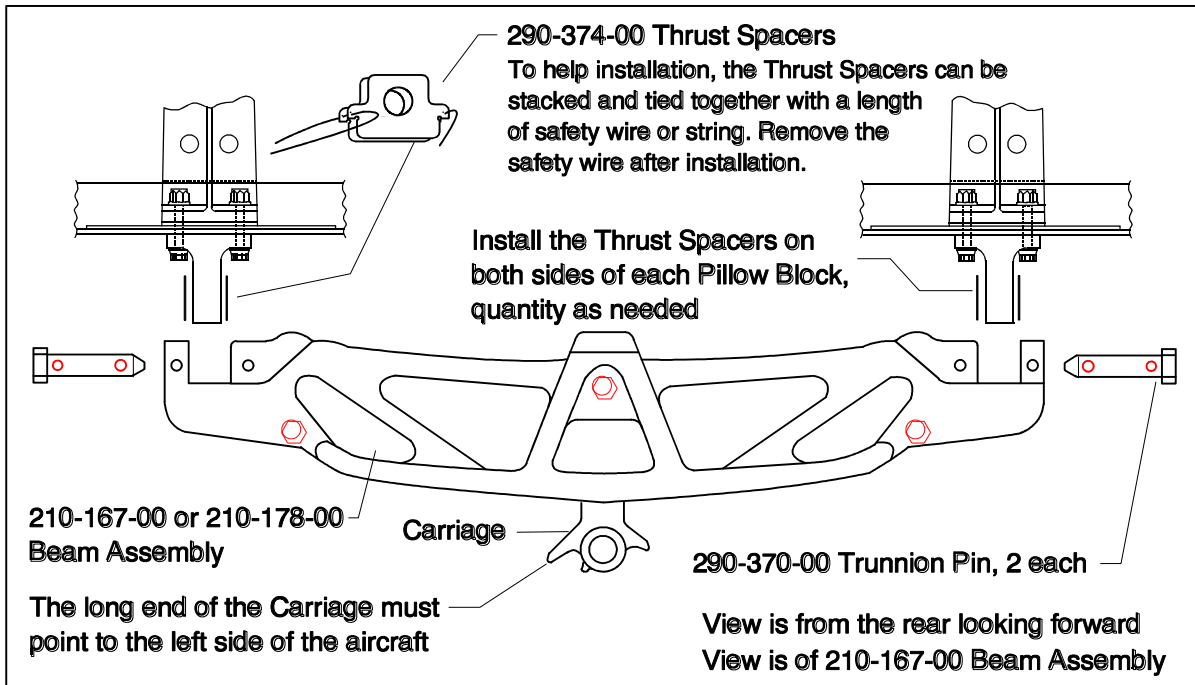

## Cargo Hook Suspension System Installation, continued

Figure 2-3 Beam Assembly, Left End Play Adjustment

Move the Beam Assembly in this direction with approximately 10 pounds force and then measure the gap between the Thrust Spacers and the Beam Assembly at the locations illustrated. Add sufficient Thrust Spacers to make the gap .00 to .060 inches at both locations.

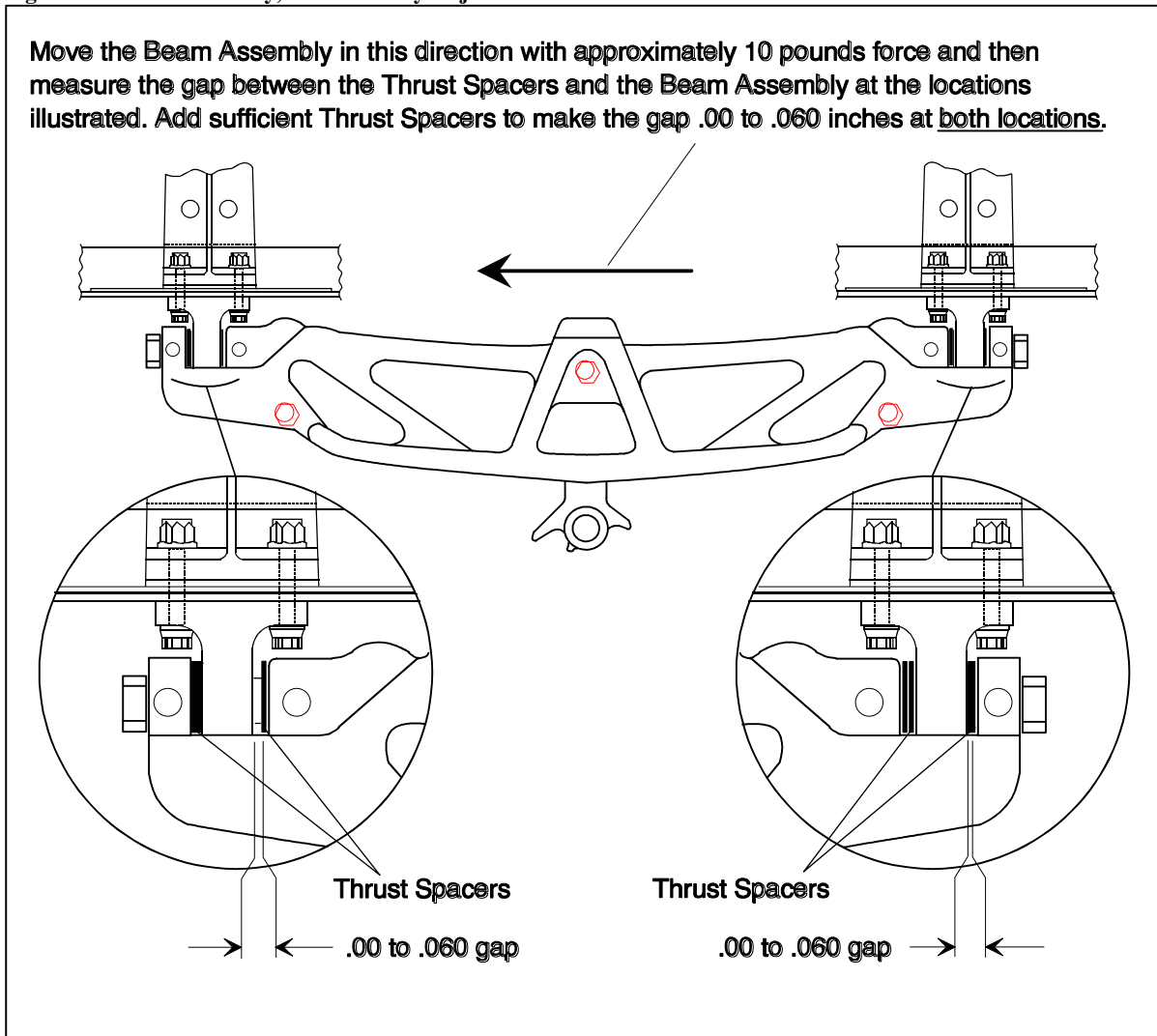

# Cargo Hook Suspension System Installation, continued

Figure 2-4 Beam Assembly, Right End Play Adjustment

Move the Beam Assembly in this direction with approximately 10 pounds force and then measure the gap between the Thrust Spacers and the Beam Assembly at the locations illustrated. Add sufficient Thrust Spacers to make the gap .00 to .060 inches at both locations.

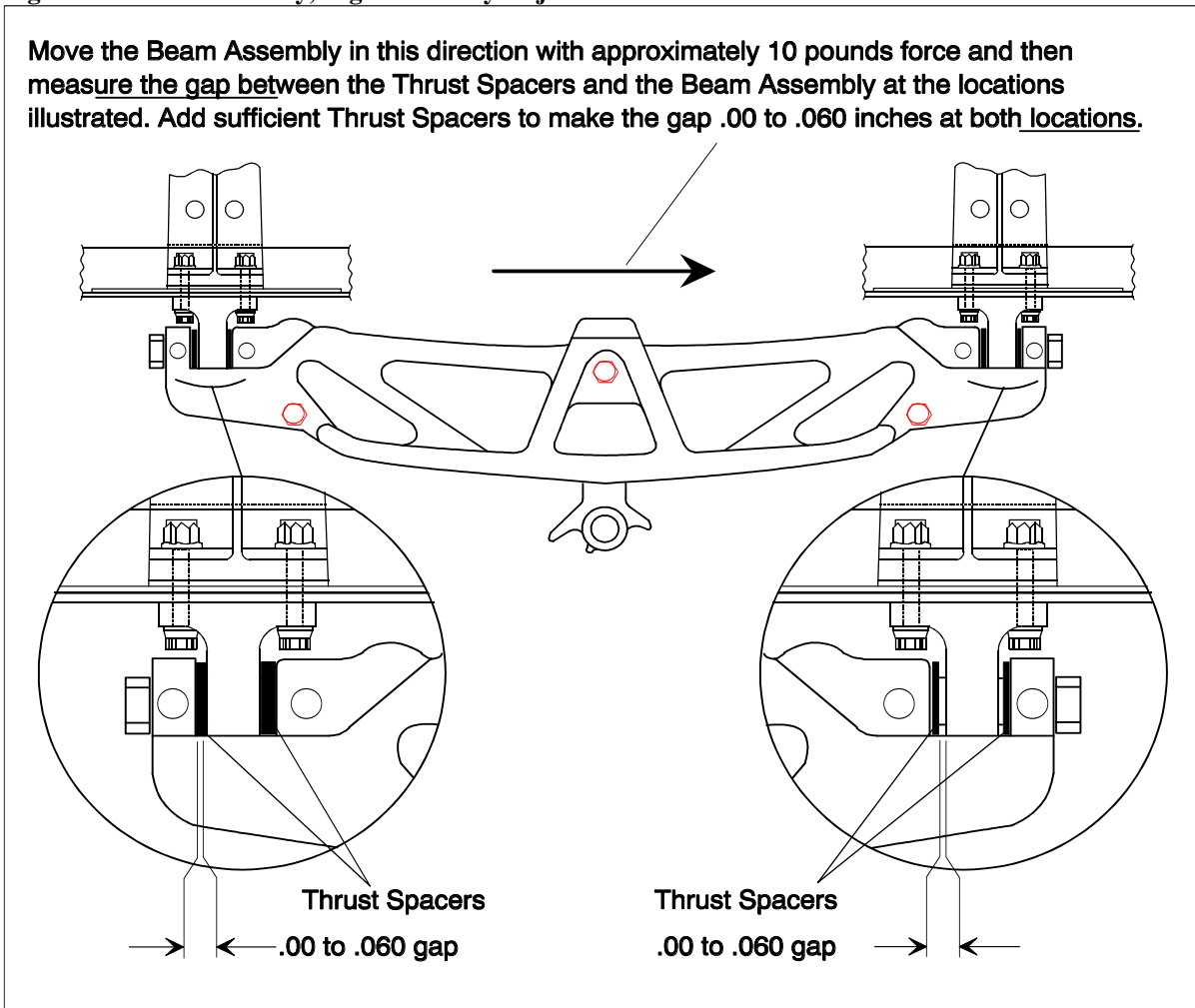



## Cargo Hook Suspension System Installation, continued

Secure the two Trunnion Pins, P/N 290-370-00, with fasteners as illustrated. Torque the 510-230-00 bolts and 510-114-00 nuts to 56-79 in-lbs. Torque the 510-229-00 bolts and 510-102-00 nuts to 20-25 in-lbs.

**Figure 2-5 Trunnion Pin Fasteners**

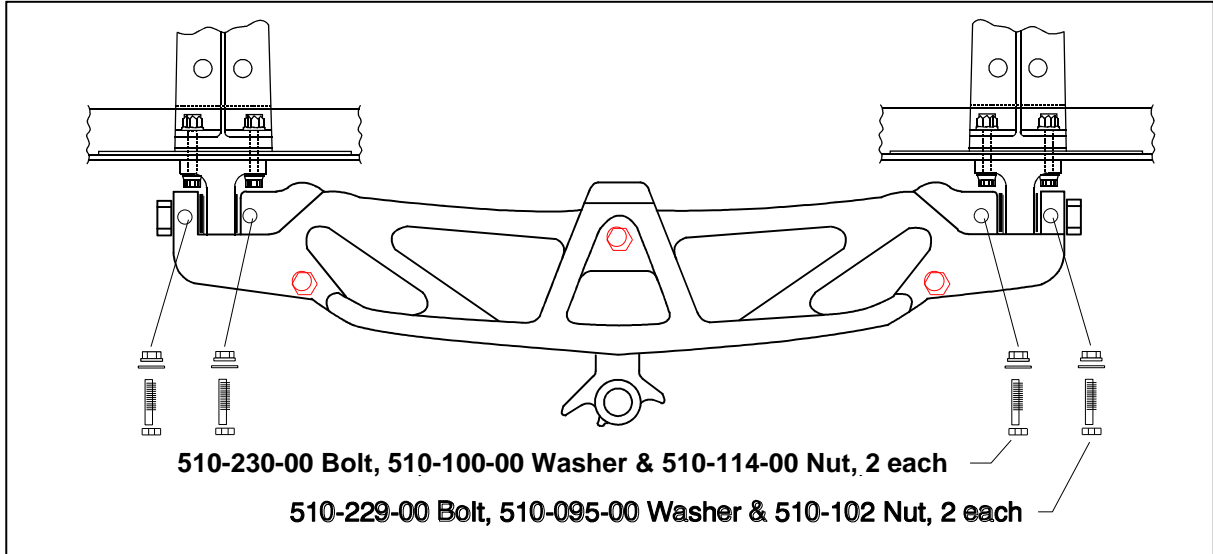

## Cargo Hook Suspension System Installation, continued

Attach the Cargo Hook, P/N 528-023-01 to the Suspension Assembly as illustrated. The Cargo Hook load beam must point to the right.

**Figure 2-6 Cargo Hook to Carriage Installation**

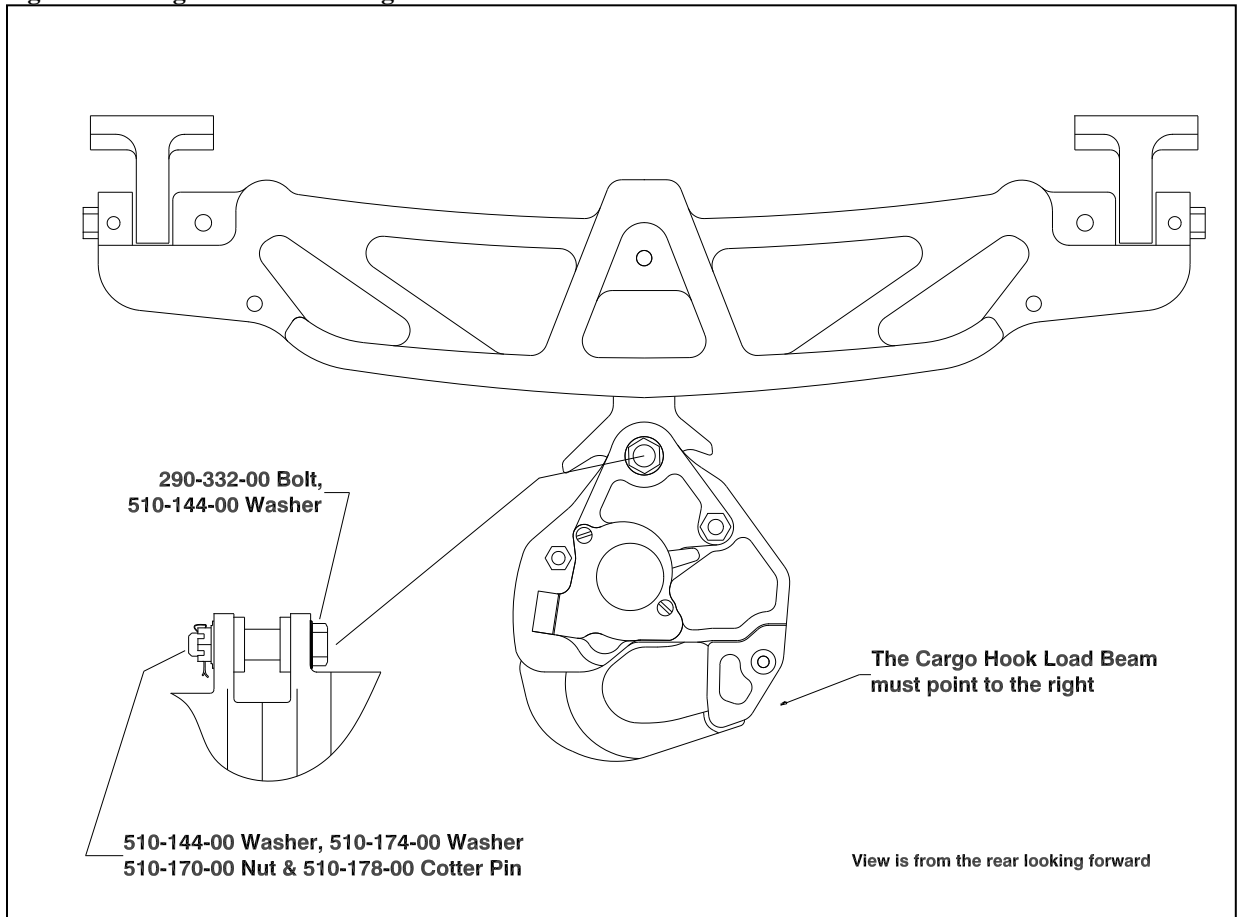

Tighten nut 510-170-00 on bolt 290-332-00 to finger tight, then rotate to next castellation to install and secure cotter pin 510-178-00.

## Cargo Hook Suspension System Installation, continued

Remove the manual release cover from the new cargo hook. Thread the manual release adapter, P/N 290-331-00 into the new cargo hook manual release boss on the hook sideplate. Connect the manual release cable to the adapter. Place the cable ball end fitting into the hook manual release fork fitting as illustrated in Figure 2-7. Move the manual release lever in the clockwise direction until it is against the cam stop (this is felt as the lever moves relatively easily for several degrees before hitting the cam stop). Measure the cable ball end free play with the manual release handle in the cockpit in the non-release position. Adjust the manual release cable system to allow a minimum of .125" of free play at the fork fitting as shown in Figure 2-7.



*Manual release cable rigging must be done with the cargo hook in the closed and locked position.*

**Figure 2-7 Manual Release Cable Rigging**

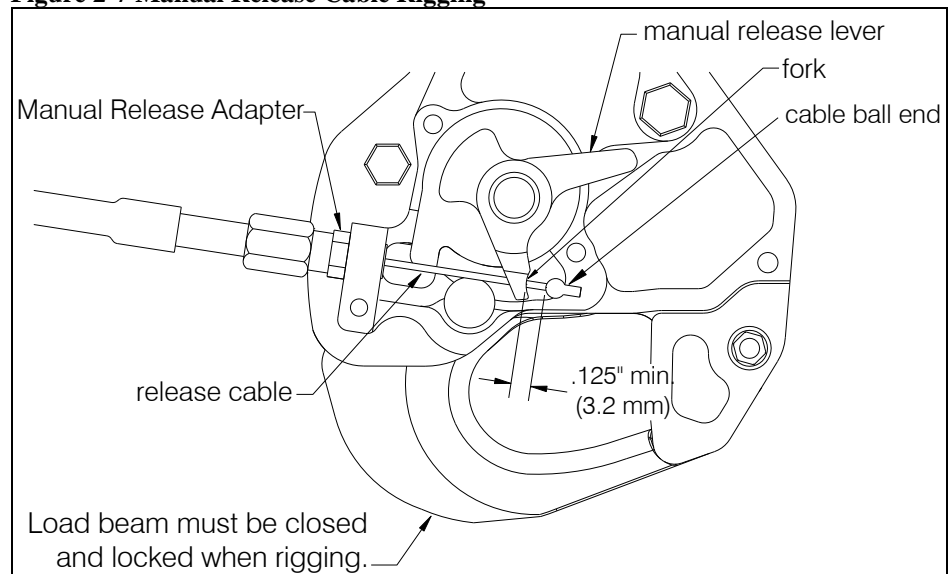

Route the Manual and the Electrical Release cables as illustrated in Figures 2-8 and 2-9.

Connect the cargo hook electrical release cable connector to the Cargo Hook. Listed below is the pin out for the cargo hook connector.

**Table 2-1 Cargo Hook Connector**

<i>Pin</i>	<i>Function</i>
A	Ground
B	Positive

## Cargo Hook Suspension System Installation, continued



Earlier versions of the cargo hook were equipped with a suppression diode that will be damaged if the cargo hook electrical connection is reversed. Do not attach the electrical connector until polarity of the aircraft connector is determined to be compatible with the Cargo Hook connector listed in Table 2-1.

Figure 2-8 Manual and Electrical Release Cable Routing, without Load Weigh

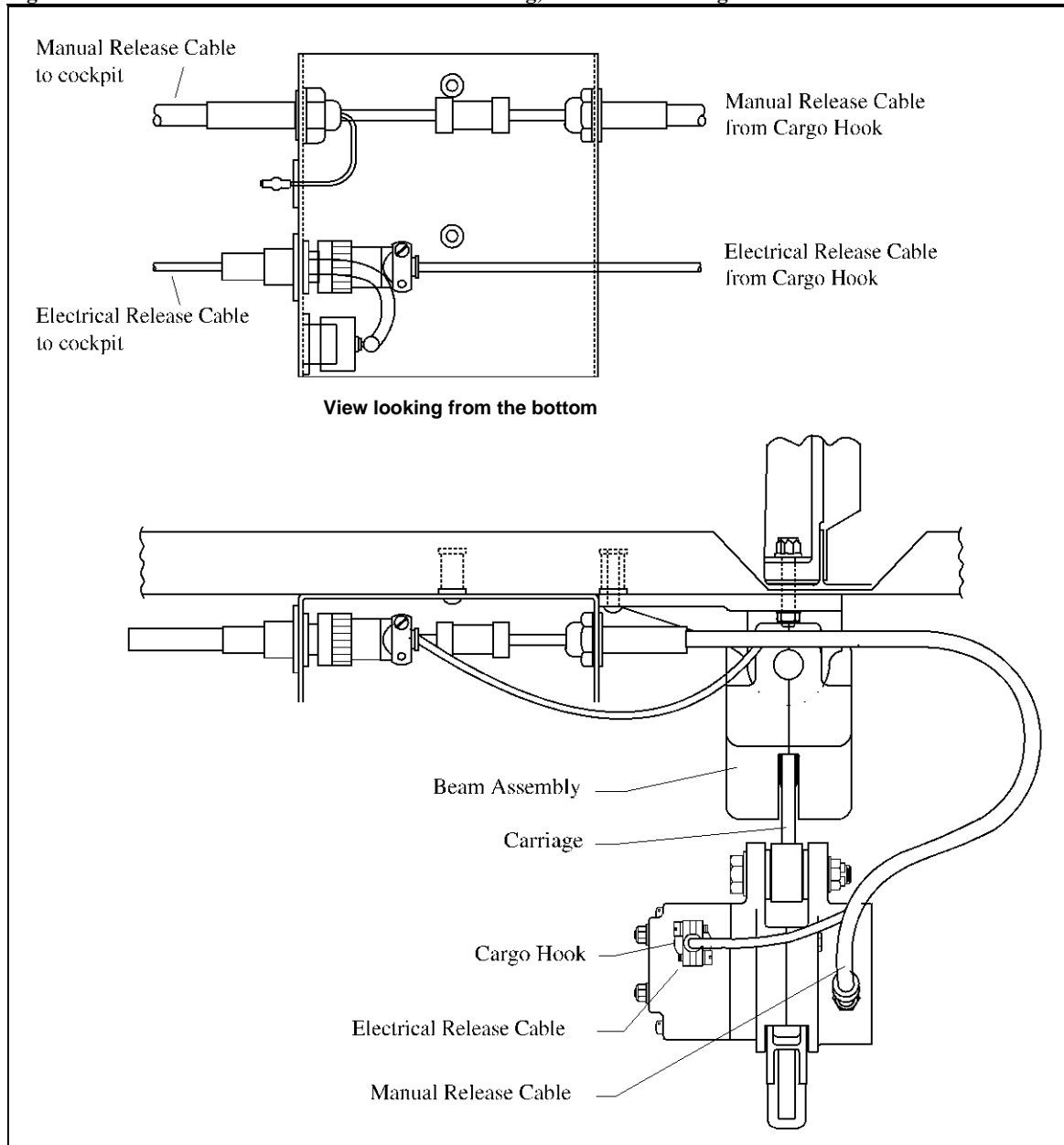

# Cargo Hook Suspension System Installation, continued

Figure 2-9 Manual and Electrical Release Cable Routing, with Load Weigh

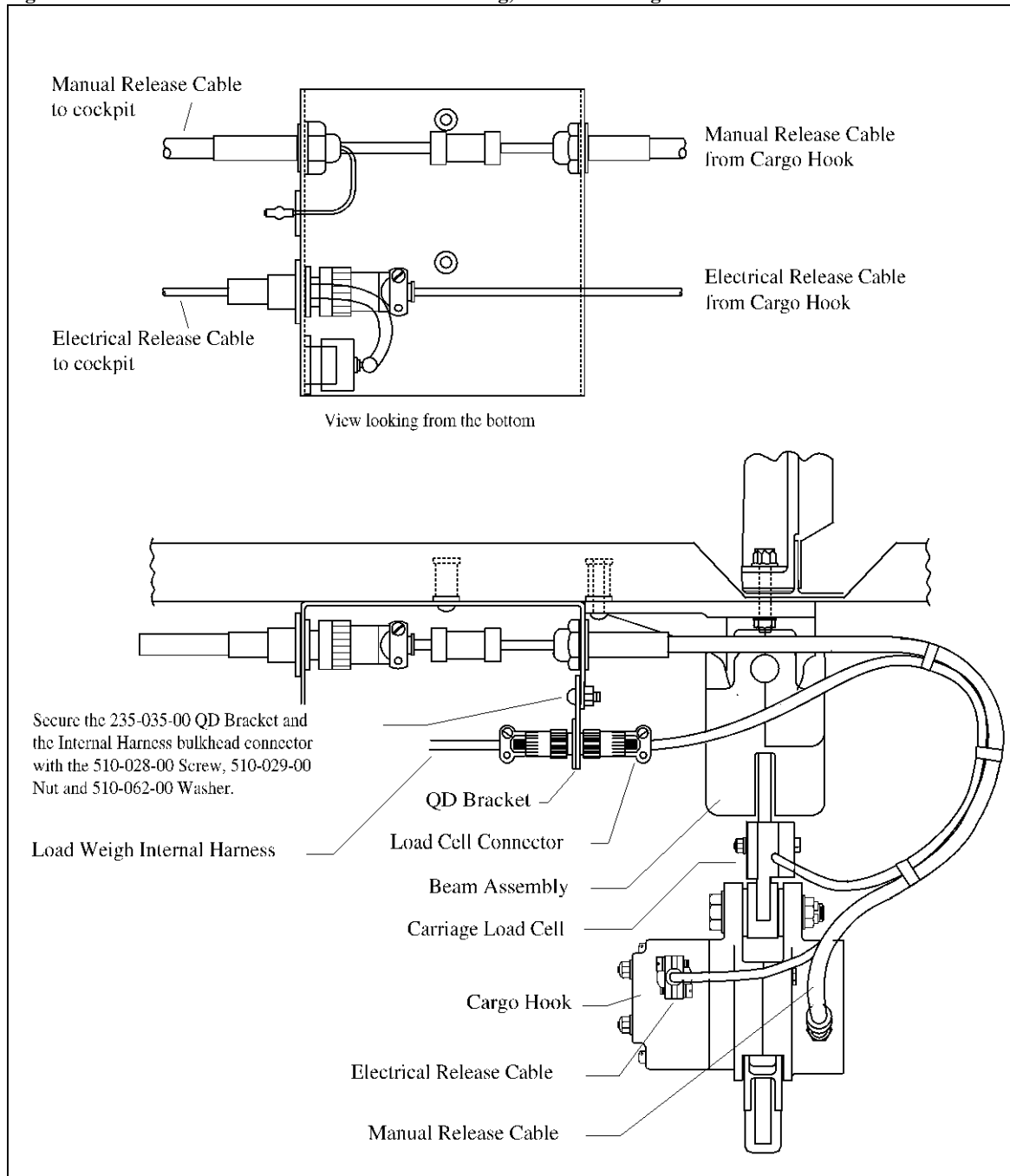

## Cargo Hook Suspension System Installation, continued



*Un-commanded cargo hook release will happen if the manual release cable is improperly restrained. The cables must not be the stops that prevent the Cargo Hook from swinging freely in all directions. If the Cargo Hook loads cause the hook to strain against the manual release cable the swaged end of the cable may separate allowing the inner cable to activate the cargo hook manual release mechanism. The result is an un-commanded release. Ensure that no combination of cyclic stick or Cargo Hook position is restrained by the manual release cable.*

**Figure 2-10 Un-commanded Release From Incorrectly Secured Cable**

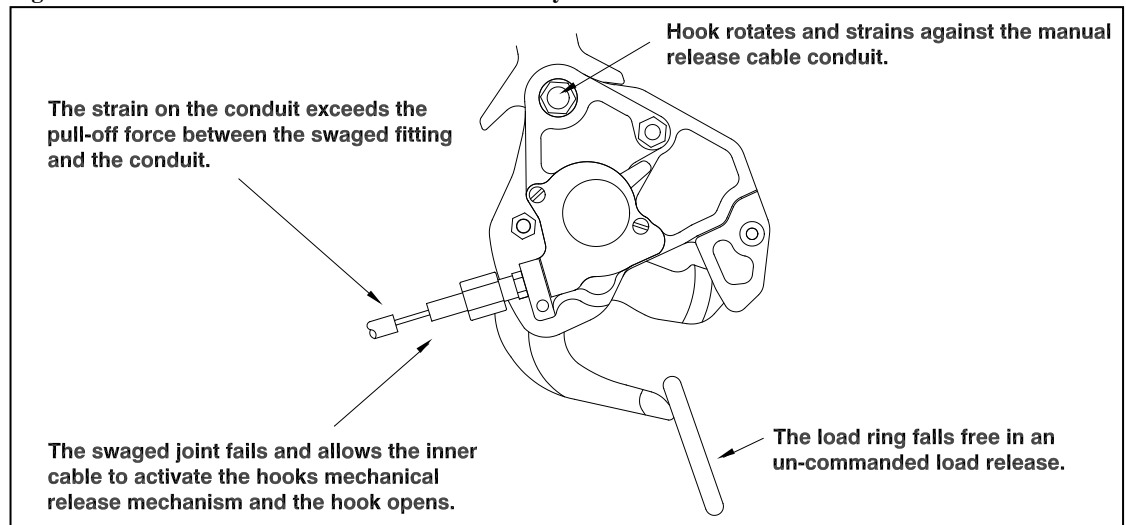

# Load Weigh System Installation Instructions

## Internal Harness Installation

The Internal Harness is made up of four cables terminated to one large connector. The connector is plugged into the back of the Indicator. One of the cables is marked "LOAD CELL" and is fitted with a bulkhead connector. Hardware is provided to attach the bulkhead connector to the Quick Disconnect Bracket, P/N 235-035-00. Attach the Quick Disconnect Bracket to the bracket that holds the manual and electrical release fittings on the skin of the aircraft at the cargo hook area.

Another cable is marked "POWER" and is connected to the aircraft electrical power. Another cable is marked "LIGHT", refer to the *Indicator Internal Back Light* section for installation instructions. The last cable is marked "DATA" and can be connected to the optional Data Recorder or Analog Slave Meter. These optional items are not included under this STC.



*The data cable may or may not be terminated with a connector depending on part number and manufacture date.*

Route the cables in the most convenient manner. Secure the cables to the existing wiring bundles with the Ty-wraps. Secure the cables clear of flight control rods.

## C-39 Cockpit Indicator Installation

The Indicator, P/N 210-095-00 or P/N 210-177-00, should be mounted in a position that is convenient, accessible and visible to the pilot. It can be mounted in a standard 2¼" instrument hole. Connect the Indicator to its Internal Harness, refer to *Internal Harness Installation*.

## Indicator Internal Back Light

The Indicator is equipped with an Internal Back Lighting System that can be connected to the aircraft 28 VDC light dimming circuit. Use a 22 gauge, twisted pair, shielded cable to connect the aircraft dimming circuit to the Internal Harness. Connect the cable shield wire to airframe ground at the light dimmer end of the cable **ONLY**.

## Indicator Hook-Open Warning

The Indicator is equipped with a Hook-Open Warning feature that can be connected to a cargo hook equipped with a hook open switch. Depending on the capabilities of the cargo hook switch, the Indicator will flash "HOOK OPEN" when the cargo hook load beam is open. The cargo hook switch must be normally open when the cargo hook load beam is in the closed position. When the load beam is open, one side of the switch must be grounded and the other side of the switch is to be connected to the Indicator. Use a 22 gauge, shielded wire to connect the cargo hook switch to the Indicator. Disassemble the Indicator mating connector and carefully solder the wire, from the cargo hook switch, to pin H. Connect the cable shield wire to airframe ground as close to the cargo hook as possible, at the cargo hook end of the cable **ONLY**.

## Remote Analog Meter

The Indicator is equipped with an Analog drive circuit that can be connected to a remote analog meter. Use a 22 gauge, twisted pair, shielded cable to connect the Remote Analog Meter to the Indicator. Disassemble the Indicator mating connector and carefully solder the positive wire, from the analog meter, to pin G and the common wire to pin F. Connect the cable shield wire to airframe ground as close to the Analog Meter as possible, at the Analog Meter end of the cable **ONLY**.

The 210-095-00 Indicator can be connected to Onboard Systems' Analog Slave Meter, P/N 210-180-00, through the "DATA" cable. This meter gives solid weight indications without needle bounce. The Analog Slave Meter may be mounted in any convenient location in a standard 3" instrument hole. Attach connector, P/N 410-130-00, to data line per pin out (Figure 2-11) to connect the Analog Slave Meter to the Internal Harness "DATA" cable. If a data connector is present on the data line use cable, P/N 270-059-00, to connect to Analog Slave Meter.

## Electrical Connections

Connect the Internal Harness to the Indicator and route the other end to a convenient location for the Indicator power switch part number 400-048-00. The cable is supplied extra long, cut off the excess cable and use as needed to connect the switch and circuit breaker. Connect the white (red wire if wire harness P/N 270-048-00 is installed) wire in the power cable to one side of the power switch, connect another piece of suitable wire to the other side of the switch and then to an available 1 or 2 amp circuit breaker. Connect the white/blue (black if wire harness P/N 270-048-00 is installed) wire to the ground bus. The bare wire (present on P/N 270-048-00 harness only) should be cut off as it is not needed at this end of the cable.



**Figure 2-11 Wiring Arrangement**

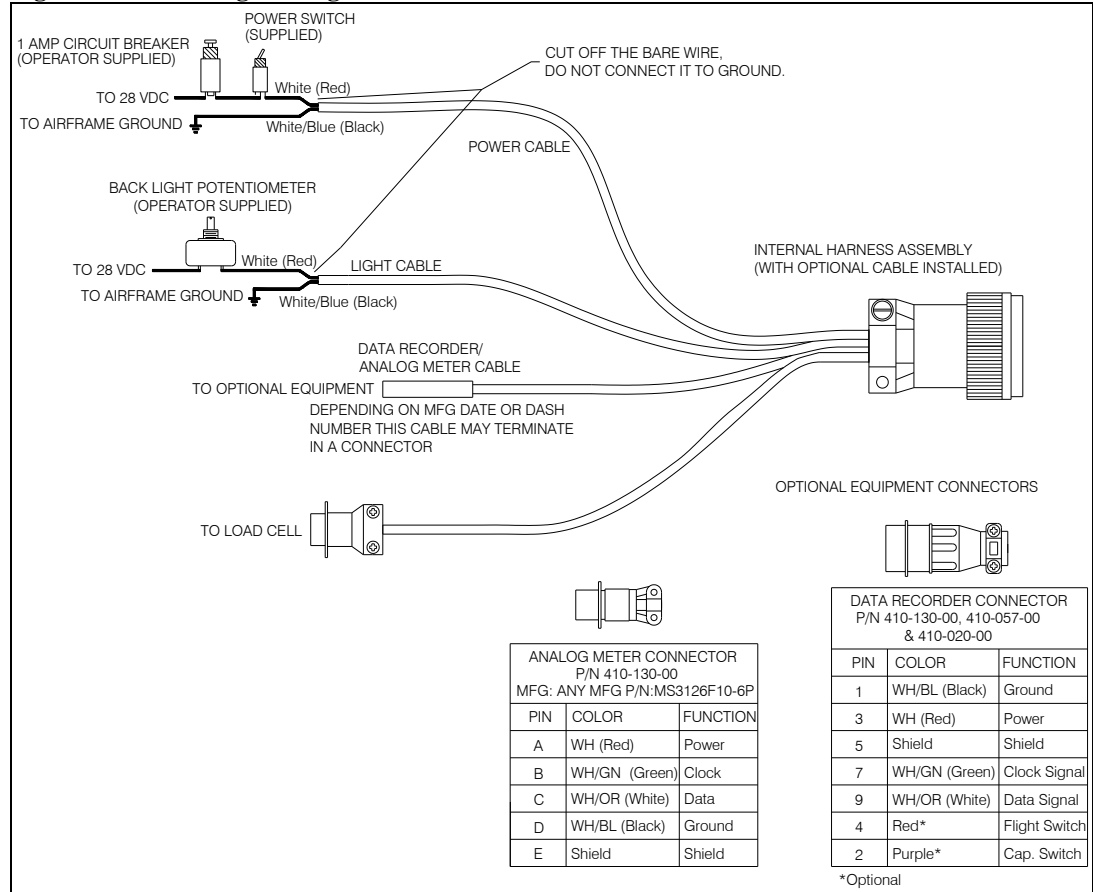

# NOTICE

*If the C-23 Printer is being utilized with the C-20 or C-30 Data Recorder, a 5 amp circuit breaker should be used.*

Install the placard 215-010-00 "ELECTRONIC WEIGHING SYSTEM" next to the power switch and circuit breaker. Install the placard 215-012-00 "TURN THE WEIGHING SYSTEM OFF WHEN NAVIGATION EQUIPMENT IN USE" "NO AIRCRAFT OPERATION SHOULD BE PREDICATED ON THE READING OF THE ONBOARD WEIGHING SYSTEM" next to the Indicator.

## Installation Check-Out

After installation of the Cargo Hook Suspension System, perform the following functional checks.

1. Swing the installed Cargo Hook on the beam to its full extremes to ensure that the manual release cable assembly and the electrical release cable have enough slack to allow full swing of the suspension assembly without straining or damaging the cables. The cables must not be the stops that prevent the Cargo Hook from swinging freely in all directions.
2. With no load on the cargo hook load beam, pull the handle operated cargo hook mechanical release, the Cargo Hook should release. Reset the cargo hook load beam.
3. Close the cargo hook release circuit breaker and position the battery switch to the ON position. With no load on the cargo hook load beam, depress the cargo hook electrical release button, the Cargo Hook should release. Reset the cargo hook load beam.
4. See the Bell Helicopter service instructions for your specific helicopter model for additional installation instructions.
5. Perform an EMI ground test per AC 43.13-lb section 11-107. For equipment that can only be checked in flight an EMI flight test may be required.

### NOTICE

*The cargo hook and load cell are of a class of equipment not known to have a high potential for interference. This class of equipment does not require special EMI installation testing (i.e. FADEC) as required in paragraphs 7 and 8 of FAA policy memorandum ASW-2001-01.*

6. Power on the Indicator and allow to warm up for 5 minutes (with no load on the hook). Press both Indicator buttons at the same time to go to the Setup Mode. Scroll through the menu until the symbol “0 in” is displayed, then press the right button. Remove any weight that is not to be zeroed out and press either button to complete the procedure.

## Component Weights

The weight of the Cargo Hook Suspension System components are listed below.

**Table 2-2 Component Weights**

<b>Item</b>	<b>Weight</b>
Suspension System W/ hook, W/O Load Cell	12.0 lbs (5.5 kgs)
Suspension System W/ hook, W/ Load Cell	12.5 lbs (5.7 kgs)
Indicator and Wire Harness	0.5 lbs (.23 kgs)

## Suspension System Location

**Table 2-3 Suspension System Location**

Fuselage Station	121.0
------------------	-------

## Paper Work

In the US, fill in FAA form 337 for the initial installation. This procedure may vary in different countries. Make the appropriate aircraft log book entry. Insert the Rotorcraft Flight Manual Supplement (document no. 121-003-00) into the Rotorcraft Flight Manual.

This page intentionally left blank.

## Section 3

# Load Weigh System Operation Instructions

## Indicator Front Panel

The C-39 Indicator front panel includes the following features.

- The four 7 segment LCD digits show the weight on the Cargo Hook and displays various Setup information.
- The Legends clarify the digital display. i.e. when the LB Legend is turned on, the display will be pounds, etc.
- The Right button is used to Zero the display in the Run Mode and select the digit to be changed in the Setup Mode.
- The Left button is used to Un-Zero the display in the Run Mode and scroll the selected digit in the Setup Mode.

Figure 3-1 Front Panel

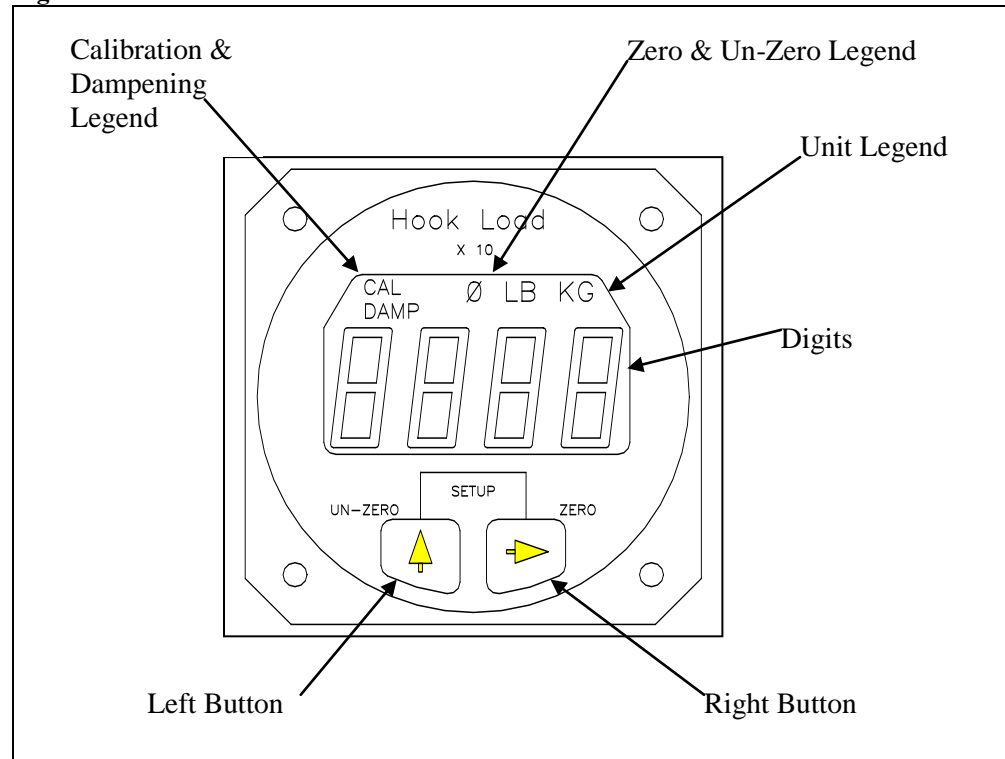

# The Run Mode

The C-39 Indicator has two operating modes, Run and Setup. The Run Mode is used to display the cargo hook weight and the Setup Mode is used to setup or configure the Indicator to the helicopter and to the Load Cell. When powered up, the Indicator always comes to life in the Run Mode.

After the Indicator has been correctly installed, power it up by activating the Load Weigh Circuit Breaker. The Indicator will go through a self diagnostic routine. During this routine the display will display all of the digits and legends. If a problem is found during the routine an Error Code will be displayed. For an explanation of Error Codes see the section *Error Codes*. After the diagnostic routine the display should look like this:

**Figure 3-2 After Diagnostic Routine**

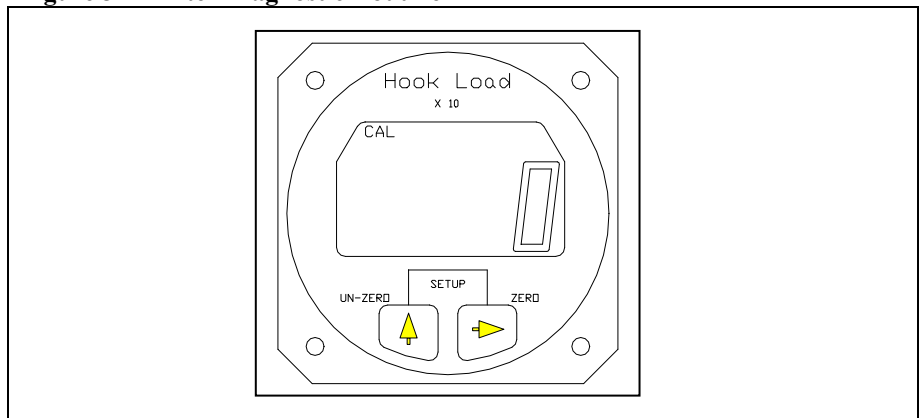

The illustration is of the Indicator in the Run Mode with no load on the hook. Note the LB legend displayed.

**Figure 3-3 LB Legend Displayed**

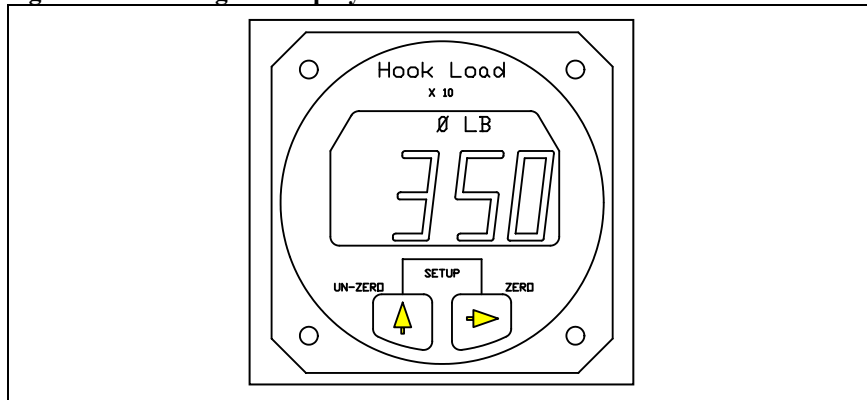

The illustration is a typical hook load reading. The display is 3,500 pounds, note the last digit is not displayed.

### ***To Zero or Tare the Display***

The zero feature is used to zero or tare the weight on the Cargo Hook that is not wanted, such as the weight of a cargo net or long line. The Right button is used to zero the Indicator reading. When the Right button is pressed the display is zeroed. The zero legend is turned on and the zeroed number is stored in memory. If the Right button is pressed again, before the Un-zero button is pressed, the display blinks in response to the button closure. Zero is only available in the Run Mode.

**Figure 3-4 Zeroing the Display**

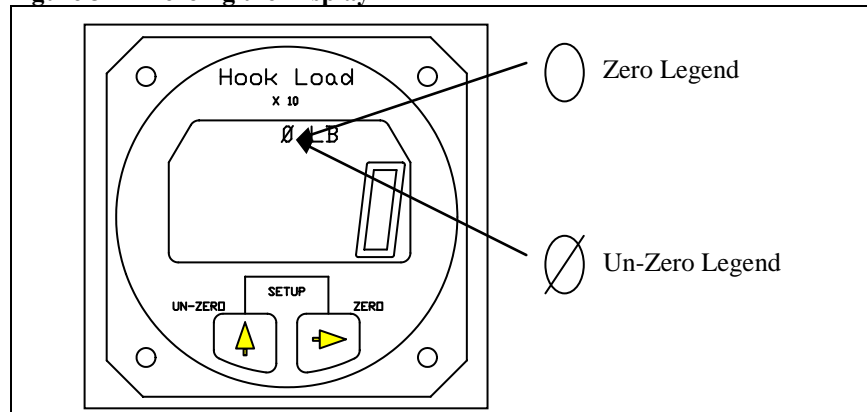

### ***To Un-Zero the Display***

The Left button is used to add the zeroed value back into the current Indicator reading or Un-zero the display. When the Left button is pressed, the number previously zeroed is added to the current display and the Un-zero legend is turned on. If the Left button is again pressed before the zero button is pressed, the display blinks in response to the button closure. Un-Zero is only available in the Run Mode.

## The Run Mode *continued*

### *Error Codes*

Error Codes are the result of difficulties discovered during the Indicator diagnostic tests. Diagnostic tests occur at power up and during the execution of certain routines. Listed below is a matrix of the Error Code displays, their meaning and possible corrective action. Pressing either button will usually bypass the error code, however, the displayed information may be suspect.

**Table 3-1 Indicator Error Codes**

<b>DISPLAY</b>	<b>CAUSE</b>	<b>POSSIBLE CORRECTIVE ACTION</b>
Err 1	A/D or D/A circuit failure	Potential short in the optional analog meter cable. Clear short and power cycle the Indicator by turning the power to the Indicator off for a few moments. If Error Code continues, return the Indicator to the factory.
Err 2	NV Ram failure	Power cycle the Indicator; if Error Code continues, return the Indicator to the factory.
Err 3	NV Ram write failure	Re-enter data, if Error Code continues, return the Indicator to the factory.
Err 4	NV Ram busy failure	Power cycle the Indicator, if Error Code continues return the Indicator to the factory.



## The Setup Mode

The C-39 Indicator can be used with a wide range of helicopters and load cells. The Setup Mode on the Indicator matches the Indicator to the Load Cell and to the helicopter. This is done by entering data into the Indicator. Entered data includes the load cell Calibration Code, the units that the Indicator should read-out (pounds or kilograms), and several other items.

The Indicator has a group of Setup routines, arranged in menu form, that are used to configure the Indicator. Shown on the next page is a matrix of the Setup routines and a brief discussion of their function and how they are programmed. A complete discussion of each setup item is presented later in this section.

To enter the Setup Mode press both the Right and Left buttons at the same time while the Indicator is powered up and in the Run Mode. To exit the Setup Mode and return to the Run Mode, press both the buttons at the same time. If you are in a Setup routine and have started to change an entry, but you change your mind before completing the procedure, power cycle the Indicator to exit the Setup Mode and then go to the Run Mode without changing the item. The Indicator is power cycled by turning the Indicator power off for a few moments.

## The Setup Mode, continued

Table 3-2 Indicator Setup Routines

MENU	FUNCTION	DISPLAY
Press the Left button to scroll through the menu	Press the Right button to view or change the menu item.	To return to the Run Mode press both the Right and Left buttons at the same time.
DAMP	<u>Dampening Level</u> , sets the pilots preference for display dampening.	Blinking display is previously entered Dampening Level. Select the desired dampening level by pressing the Left button.
CODE	<u>Calibration Code</u> , matches the Indicator to the Load Cell.	Display is previously entered CAL Code. The Code is changed by selecting the digit to be changed with the Right button. The selected digit will blink. Change the blinking digit by pressing the Left button.
0 in	<u>Installation ZERO</u> , matches the Indicator to the installed Load Cell and to the helicopter. After this procedure the display will be zero when no load is on the Cargo Hook.	Display is a combination of load on the Load Cell, and normal load cell zero offset. Remove all weight from the installed Load Cell except the Cargo Hook, and press any button to complete the procedure and return to the Run Mode.
LOAD	<u>Load</u> , is used to calibrate the system by lifting a known load.	No previous display is shown. Enter the known load using the Right button to select the digit to be changed and Left button to enter the number. Known load is entered "X 10" i.e.; 5000 kilograms is entered as 500. After the known load is entered, press both buttons at the same time and lift the known load. When the load is stabilized press either button. A new Calibration Code will be calculated and the known load will be displayed. This completes the procedure.
Scale	<u>Scale</u> , matches the analog output of the Indicator to an optional remote analog meter.	Display is previously entered number. To change the number use the Right button to select a digit, use the Left button to scroll the digit to the desired number. Entry is times 10.
LB KG	<u>Units</u> , selects the Indicator units (pounds or kilograms).	Display is previously selected unit. To change the unit, use the Left button.
XX - V	<u>Version</u> , is the revision level of the Indicator hardware and software.	Version is for information only, it cannot be changed.

## The Setup Mode, continued

### *Indicator Dampening*

The Damp or dampening routine allows the pilot to adjust the Indicator dampening level to his preference. The dampening routine is a program that stabilizes the Indicator reading. It offers a trade-off between Indicator responsiveness and stability. Ten dampening levels are available, from 0 through 9. At level 0 the display responds to the slightest change in weight. However, if the load bounced even slightly, the display digits would respond instantly, making the display look unstable. With a dampening level of 9, the display would be stable under the most turbulent conditions, however, it would take several seconds for the display to respond to a change in weight. The ideal dampening level will depend on the flying conditions. A mid range setting of 5 or 6 is usually adequate.

### *To Look at or Change the Dampening Level*

With the Indicator powered up and in the Run Mode, press both buttons at the same time to go to Setup. Scroll through the menu, using the Left button, until the word DAMP is displayed. To look at or change the Dampening Level press the Right button. The display should look like this:

**Figure 3-5 Changing Dampening Level**

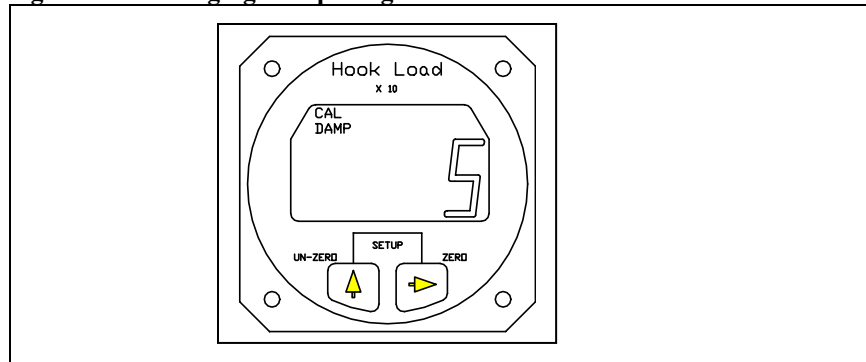

The CAL and the DAMP legend is turned on and the previously set dampening level is displayed. To return to Run without changing the current dampening level press both the Right and Left buttons at the same time. To change the dampening number, use the Left button to scroll the blinking digit to the desired number. After the selection has been made press both the Right and Left buttons at the same time to return to Run.

### *Indicator Calibration*

The Calibration Code, or CAL code, is a mandatory input. The Indicator will not accurately display the load without the correct Calibration Code. The Calibration Code scales the signal from the Load Cell.

If the C-39 Indicator was supplied as part of a Load Weigh System, the Calibration Code will have been entered into the Indicator by the factory, however, it should be confirmed. If the Indicator is to be mated to a different Load Cell, it must be calibrated before use. Calibration can be done by entering a known Calibration Code or by lifting a known load and having the Indicator calibrate itself. Both options are discussed below.

## The Setup Mode, continued

### *To Look at or Change the Calibration Code*

With the Indicator powered up and in the Run Mode, press both buttons at the same time to go to Setup. Scroll through the menu until the word CODE is displayed, then press the Right button. The display should look like this:

**Figure 3-6 Changing the CAL Code**

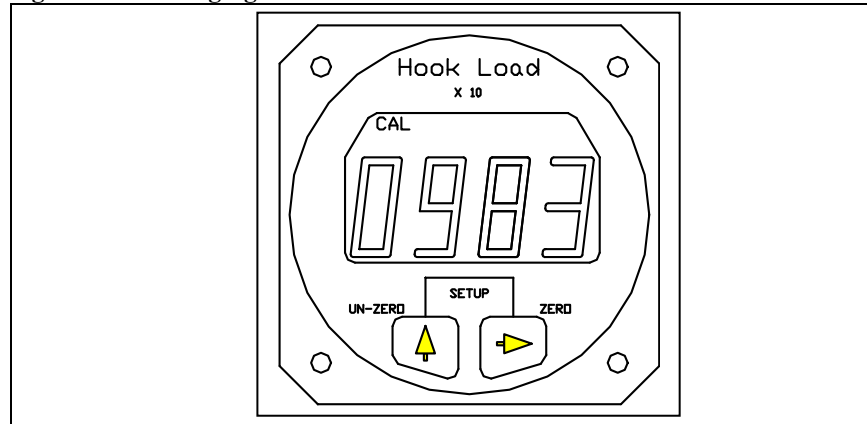

The CAL legend is turned on and the previously entered or computed Calibration Code is displayed. To return to Run without changing the CAL Code, press both the Right and Left buttons at the same time. To change the Calibration Code, use the Right button to select the digit to be changed, then use the Left button to scroll the blinking digit to the desired number. When the Calibration Code has been entered, press both the Right and Left button at the same time to return to Run.

## NOTICE

*Depending on the type of Load Cell, the Calibration code could be a 3 or 4 digit number. If the Calibration Code is a 3 digit number a leading zero (0) must be used. For example if a Load Cell had a CAL Code of 395 it would be entered as 0395.*

If the load cell Calibration Code is not known or as a cross check, the Indicator can generate the Calibration Code. This is done by entering the weight of a known load into the Indicator LOAD routine and then lifting the load. See the section *Calibration by Lifting a Known Load*.

## The Setup Mode, continued

### *Installation Zero*

Installation zero is a routine that matches the Indicator to the ***INSTALLED*** Load Cell. It adjusts the Indicator reading to compensate for the weight of the Cargo Hook on the Load Cell and whatever zero offset is built into the Load Cell. The Installation Zero procedure is not mandatory. If done the Indicator will read zero when the Un-Zero button is pressed and there is no weight on the Cargo Hook. If the Installation Zero is not done, the Indicator will show the weight of the Cargo Hook plus the value of the Load Cell zero offset.

### *To Run the Installation Zero Routine*

With the Indicator powered up and in the Run Mode, press both buttons at the same time to go to Setup. Scroll through the menu until the symbol "0 in" is displayed, then press the Right button. The CAL legend will be turned on and the current weight on the Cargo Hook will be displayed and blinking. Remove any weight that is not to be zeroed out and press either button to complete the procedure and return to the Run Mode.

### *Calibration by Lifting a Known Weight*

Calibration by lifting a known weight is a Setup routine that calculates the Calibration Code for the Load Cell attached to the Indicator. It is useful if the load cell Calibration Code is not known or as a cross check to the accuracy of a known Calibration Code. The procedure is done by entering the known weight into the Indicator and then lifting the weight. This procedure can be done in the shop or on the helicopter. The accuracy of the procedure is directly related to the weight of the known load. If for example the procedure was done with a 1,000 pound load that was assumed to weigh only 900 pounds, all subsequent lifts would be displayed 10% light.



*Be sure to include the weight of everything between the Cargo Hook and the load, i.e. the cable, net, dirt, etc.*

The closer the known load approaches the lifting capacity of the helicopter, the more accurate the calculated Calibration Code will be.

## The Setup Mode, continued

### To Run the Calibration by Lifting a Known Weight Routine

With the Indicator powered up and in the Run Mode, press both buttons at the same time to go to Setup. Scroll through the menu until the word LOAD is displayed, then press the Right button. The display should look like this:

Figure 3-7 Running CAL Routine

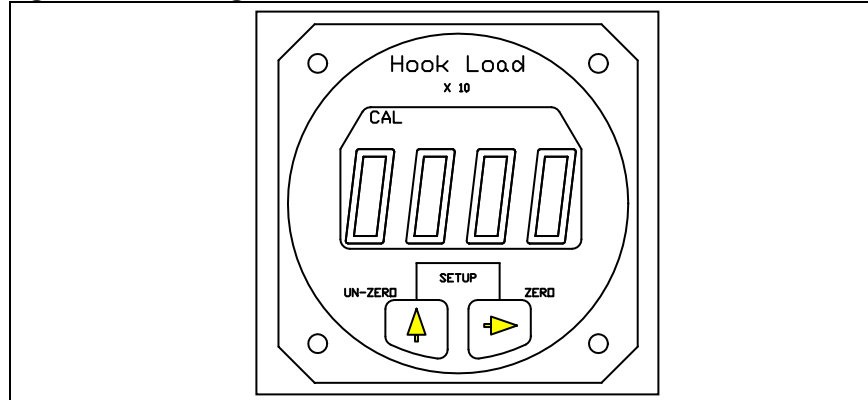

The CAL legend is turned on and the first digit is blinking. The previous load is not displayed. At this point if you wish to return to the Run Mode without changing the Calibration Code, power cycle the Indicator. At this point it is not possible to return to the Run Mode without changing the Calibration Code by using the buttons on the Indicator front panel.

To proceed with the procedure, use the Right button to select the digit to be changed, then use the Left button to scroll the blinking digit to the desired number. Note that the known weight is entered "X 10"; a 1000 pound load is entered as 100. When the known load has been entered, press both the Right and Left button at the same time. The display will look like this:

Figure 3-8 Entering Load in CAL Routine

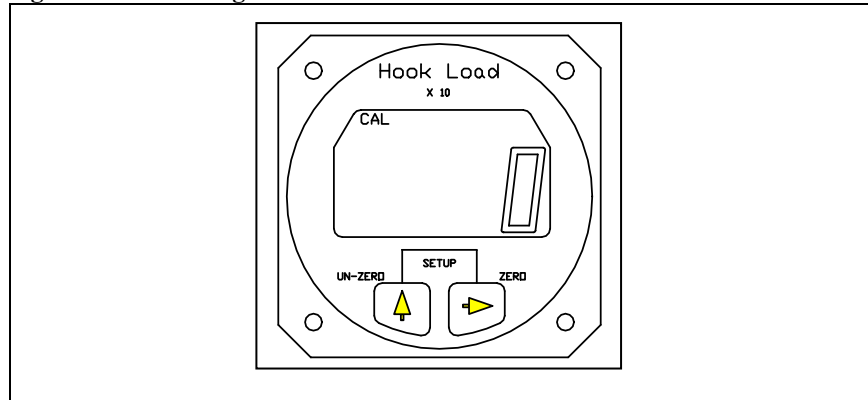

# The Setup Mode, continued

## *Calibration by Lifting a Known Weight, continued*

The CAL legend and the digits will be blinking. Again, at this point if you wish to return to the Run Mode without changing the Calibration Code, power cycle the Indicator. It is not possible to return to the Run Mode by using the buttons on the Indicator front panel without changing the Calibration Code. If you wish to proceed, lift the known load and when it is stabilized, press either button to complete the procedure. The Indicator will display the load. This ends the procedure. The Indicator is now calibrated to the Load Cell. It is a good practice to go to the Code routine and record the new Calibration code for later reference.

## *Setting the Scale for a remote analog meter*

The Scale routine is used when a user supplied analog meter is connected to the Indicator. It is used to match or calibrate the analog meter to the Indicator. The Indicator outputs a 0 to 5 VDC analog signal which is proportional to the Load Cell load. The Scale number tells the Indicator at what point in pounds or kilograms it should reach the 5 VDC output. If for example a 5 volt analog meter is used and its full scale reading is 10,000 pounds, the number entered into the Indicator Scale routine would be 1000 (the number is entered X 10). This number tells the Indicator that it should output the proportional 0 to 5 VDC signal between zero pounds and 10,000 pounds.

The Scale number does not affect Onboard Slave Meters, P/N 210-106-00 or 210-180-00. This number only affects user supplied instruments connected to the analog out signal.

## *To Look at or Change the Scale*

With the Indicator powered up and in the Run Mode, press both buttons at the same time to go to Setup. Scroll through the menu until the word SCALE is displayed, then press the Right button. The display should look like this:

**Figure 3-9 Changing the Scale**

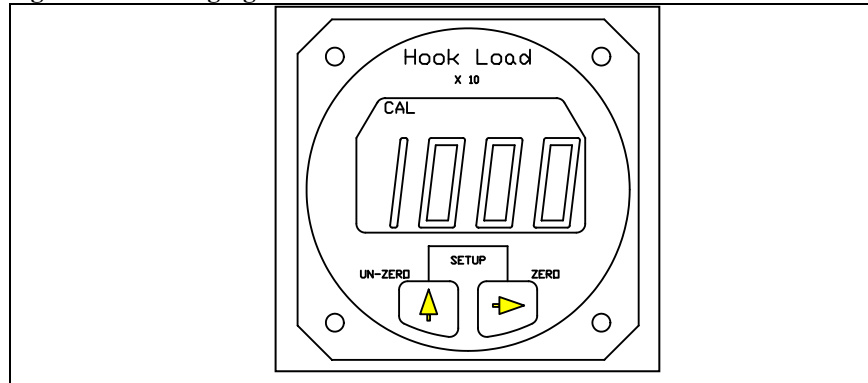

## The Setup Mode, continued

### *To Look at or Change the Scale, continued*

The CAL legend is turned on and the previously set Scale number is displayed. To return to Run without changing the Scale, press both the Right and Left button at the same time. To change the Scale number, use the Right button to select a digit to be changed, then use the Left button to scroll the blinking digit to the desired number. When the complete Scale number has been entered, press both the Right and Left button at the same time to return to Run.

### *Select KG or LB Units*

The units routine sets the display to read in pounds (LB) or kilograms (KG).

### *To look at or change the Units*

With the Indicator powered up and in the Run Mode, press both buttons at the same time to go to Setup. Scroll through the menu until the word LB or KG is displayed, then press the Right button. The display should look like this:

**Figure 3-10 Changing the Units**

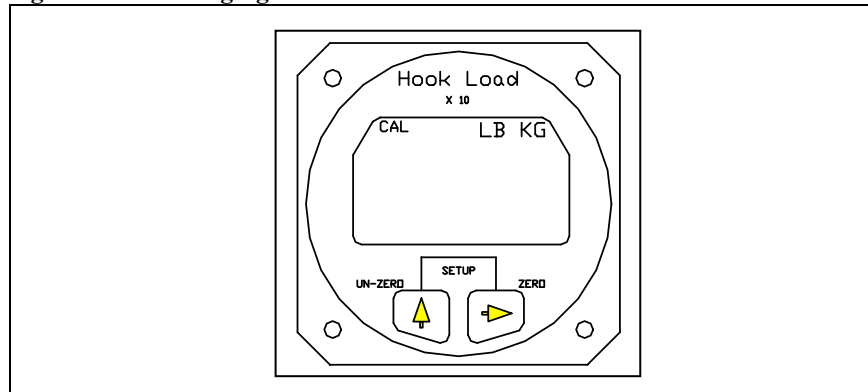

The CAL legend is turned on and the previously set unit is displayed. To return to Run without changing the units, press both the Right and Left button at the same time. To change the units press the Left button. When the selection has been made, press both the Right and Left button at the same time to return to Run.

**NOTICE**

*The selected units are displayed when in the Run Mode.*



## The Setup Mode, continued

### *Indicator Version*

The Version routine displays the Indicator's hardware and software revision levels. Version is set at the factory and cannot be changed.

**Figure 3-11 Looking at Indicator Version**

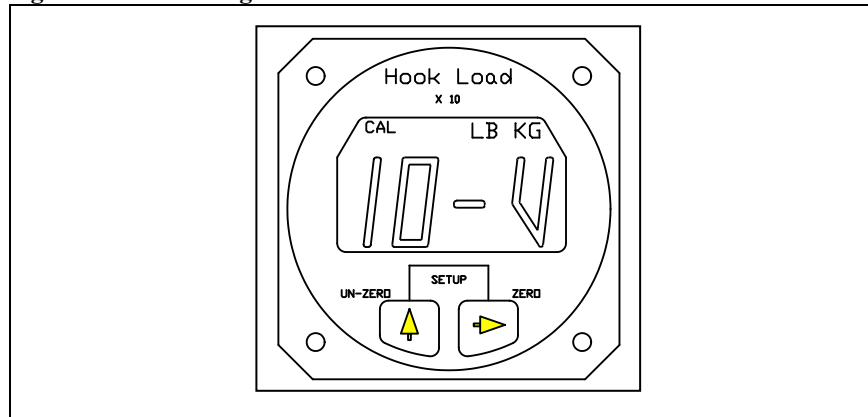

This page intentionally left blank.

## *Section 4*

# Operation Instructions

## Operating Procedures

Prior to a flight involving external load operations perform the following:

1. Ensure that the Cargo Hook Kit has been properly installed and that the manual and electrical release cables do not limit the movement of the hook.
2. Be completely familiar with this Owner's Manual, Cargo Hook Component Maintenance Manual 122-005-00 and the ICA Maintenance Manual 123-007-00.
3. Activate the electrical system and press the Cargo Hook release button to ensure the cargo hook electrical release is operating correctly. The Cargo Hook must release. Reset the hook by hand after release. If the hook does not release or re-latch, do not use the unit until the difficulty is resolved.



*The release solenoid is intended to be energized only intermittently. Depressing the electrical release button continuously in excess of 20 seconds will cause the release solenoid to overheat, possibly causing permanent damage.*

4. Activate the manual release lever to test the cargo hook manual release mechanism. The mechanism should operate smoothly and the Cargo Hook must release. Reset the hook by hand after release. If the hook does not release or re-latch, do not use the unit until the difficulty is resolved.

## Cargo Hook Loading

The cargo hook can easily be loaded with one hand. A load is attached to the hook by pushing the ring upward against the upper portion of the load beam throat, as illustrated in Figure 4-1, until an internal latch engages the load beam and latches it in the closed position.

**Figure 4-1 Cargo Hook Loading**

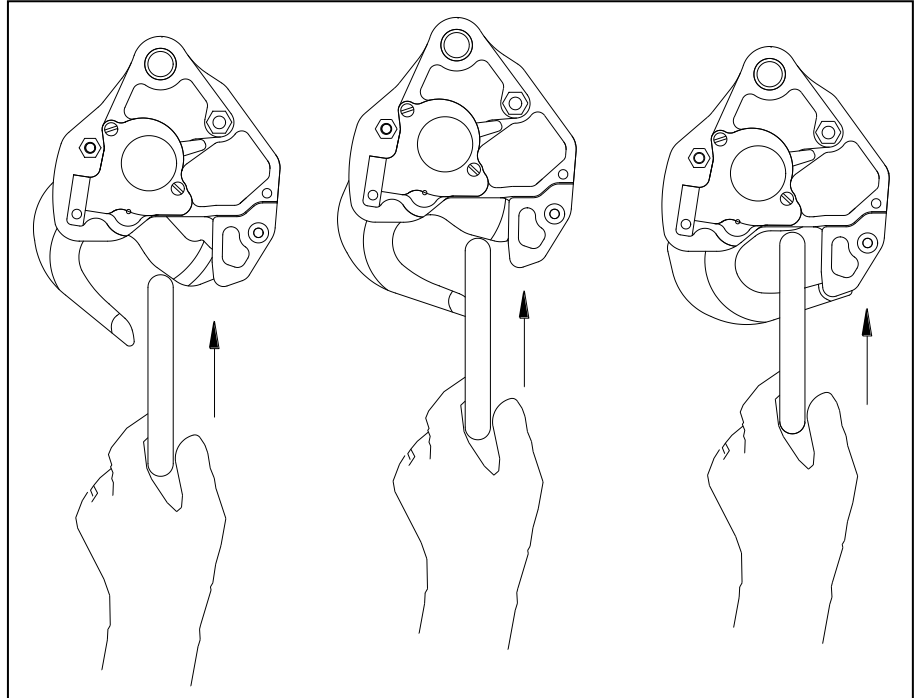

## Cargo Hook Rigging

Extreme care must be exercised when rigging a load to the Cargo Hook. Steel load rings are recommended to provide consistent release performance and resistance to fouling. Figure 4-2 shows the recommended rigging and rigging to avoid, but is not intended to represent all rigging possibilities.

### **WARNING**

*It is the responsibility of the operator to ensure the cargo hook will function properly with each rigging.*

### **WARNING**

*Nylon type straps (or similar material) or rope must not be used directly on the cargo hook load beam. If nylon straps or rope must be used they should be first attached to a steel primary ring. Verify that the ring will freely slide off the load beam when it is opened. Only the primary ring should be in contact with the cargo hook load beam.*

**Figure 4-2 Examples of Cargo Hook Rigging**

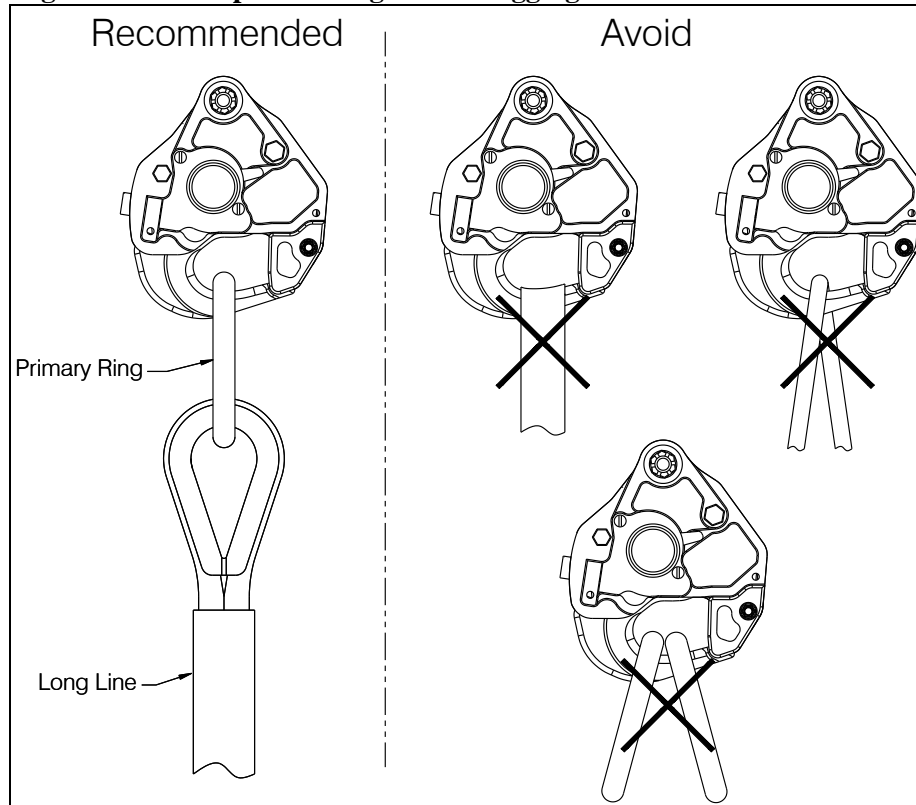

This page intentionally left blank.

# Section 5

## *Maintenance*

Refer to the Instructions for Continued Airworthiness (ICA) manual 123-007-00 for maintenance of the cargo hook suspension system. For maintenance of the cargo hook refer to Cargo Hook Service Manual 122-005-00.

### **Instructions for Returning Equipment to the Factory**

If an Onboard Systems product must be returned to the factory for any reason (including returns, service, repairs, overhaul, etc) obtain an RMA number before shipping your return.



*An RMA number is required for all equipment returns.*

To obtain an RMA, please use one of the listed methods.

- Contact Technical Support by phone or e-mail ([Techhelp@OnboardSystems.com](mailto:Techhelp@OnboardSystems.com)).
- Generate an RMA number at our website: <http://www.onboardsystems.com/rma.php>

After you have obtained the RMA number, please be sure to:

- Package the component carefully to ensure safe transit.
- Write the RMA number on the outside of the box or on the mailing label.
- Include the RMA number and reason for the return on your purchase or work order.
- Include your name, address, phone and fax number and email (as applicable).

Return the components freight, cartage, insurance and customs prepaid to:

Onboard Systems  
13915 NW 3rd Court  
Vancouver, Washington 98685  
USA  
Phone: 360-546-3072

This page intentionally left blank.



# Section 6 Certification

## FAA STC

United States of America  
Department of Transportation—Federal Aviation Administration

# Supplemental Type Certificate

*Number* SR00898SE

*This certificate, issued to:* Onboard Systems  
13915 NW 3rd Court  
Vancouver, WA 98685

*certifies that the change in the type design for the following product with the limitations and conditions therefore as specified hereon meets the airworthiness requirements of Part 6 of the Civil Air Regulations.*

*Original Product—Type Certificate Number* H2SW  
*Make:* Bell  
*Model:* 206L, 206L-1, 206L-3, 206L-4, and 407

*Description of the Type Design Change:* Fabrication of Onboard Model 200-258-00 (without load weigh), 200-259-00 (with load weigh) or 200-259-01 (with load weigh and 5V Lighting) cargo hook system in accordance with Onboard Master Drawing List No. 155-058-00, Rev. 8, dated September 16, 2008, or later FAA-approved revision; and installation and inspection of these Onboard cargo hook systems in accordance with FAA-approved Onboard Systems Instructions for Continued Airworthiness Document 123-007-00, Rev. 5, dated April 17, 2007, Cargo Hook Owner's Manual, Document 120-092-00, Rev. 8, dated September 15, 2008, and Cargo Hook Service Manual, Document 122-005-00, Rev. 1, dated November 9, 2000, or later FAA-approved revisions.

*Limitations and Conditions:* Approval of this change in type design applies only to those Bell model rotorcraft listed above, which are equipped with an FAA approved installation of a Bell Auxiliary Equipment Kit - Cargo Hook Provisions, P/N's 206-706-341-7, -9, -103, -111, -113, -117, -123 or -125 only. This approval should not be extended to other rotorcraft of these models on which other previously approved modifications are incorporated unless it is determined by the installer that the relationship between this change and any of those other previously approved modifications, including changes in type design, will introduce no adverse effect upon the airworthiness of that rotorcraft. This modification has been approved by the FAA for Class B and C Rotorcraft-Load Combinations, Non-human External Cargo only. Modified rotorcraft must be operated in accordance with FAA-approved Onboard Rotorcraft Flight Manual Supplement (RFMS) No. 121-003-00, Rev. 2, dated August 2, 2007, or later FAA-approved revision. A copy of this certificate and FAA-approved RFMS must be maintained as part of the permanent records for the modified rotorcraft.

If the holder agrees to permit another person to use this certificate to alter the product, the holder shall give the other person written evidence of that permission.

*This certificate and the supporting data which is the basis for approval shall remain in effect until surrendered, suspended, revoked, or a termination date is otherwise established by the Administrator of the Federal Aviation Administration.*

*Date of application:* September 22, 2000  
*Date of issuance:* March 26, 2001

*Date reissued:*  
*Date amended:* January 13, 2003, October 9, 2008



*By direction of the Administrator*

  
(Signature)

Acting Manager, Seattle Aircraft  
Certification Office

(Title)

Any alteration of this certificate is punishable by a fine of not exceeding \$1,000, or imprisonment not exceeding 3 years, or both.

This certificate may be transferred in accordance with FAR 21.47.

FAA FORM 8110-2(10-88)

# Canadian Approval



Transport Canada Transports Canada

Department of Transport

## Supplemental Type Certificate

This approval is issued to:

Onboard Systems  
13915 NW 3rd Court  
Vancouver, Washington  
United States of America 98685

**Number:** SH05-33

**Issue No.:** 1

**Approval Date:** July 04, 2005

**Issue Date:** July 04, 2005

**Responsible Office:**

Pacific

**Aircraft/Engine Type or Model:**

BELL 206L, 206L-1, 206L-3, 206L-4, 407

**Canadian Type Certificate or Equivalent:**

H-92

**Description of Type Design Change:**

Installation of Onboard System Model 200-258-00, 200-259-00 or 200-259-01 Hook System per FAA STC SR00898SE

**Installation/Operating Data,  
Required Equipment and Limitations:**

Installation and Inspection of Onboard Systems Model 200-258-00 (without load weigh) or 200-259-00 (with load weigh) or 200-259-01 (with load weigh and 5V Lighting) cargo hook system is to be carried out in accordance with Onboard Systems Instructions for Continued Airworthiness Document 123-007-00, Revision 3, dated May 9, 2005; FAA approved Onboard Systems Cargo Hook Owner's Manual Document 120-092-00, dated January 23, 2001 and Cargo Hook Service Manual, Document 122-005-00, Revision 1, dated November 9, 2000. This cargo hook suspension system is to be fabricated in accordance with FAA approved Onboard Systems Master Drawing List No. 155-058-00, dated January 24, 2001.

This modification has been approved by the FAA for Class B and C Rotorcraft-Load Combinations, Non-human External Cargo only.

Approval of this change in type design applies to Bell model rotorcraft listed above, which were previously equipped with an FAA approved installation of Bell Auxiliary Equipment Kit - Cargo Hook Provisions P/N 206-706-341-7, -9, -103, -111, or -113 only. Modified rotorcraft must be operated in accordance with an FAA approved copy of Onboard Rotorcraft Flight Manual Supplement No. 121-003-00, dated March 26, 2001.

— End —

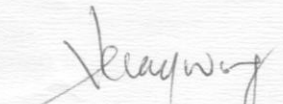

**Conditions:** This approval is only applicable to the type/model of aeronautical product specified therein. Prior to incorporating this modification, the installer shall establish that the interrelationship between this change and any other modification(s) incorporated will not adversely affect the airworthiness of the modified product.

  
Henry Wong  
For Minister of Transport

Canada



European Aviation Safety Agency

## SUPPLEMENTAL TYPE CERTIFICATE

**EASA.IM.R.S.00595**

This certificate, established in accordance with Regulations (EC) No 1592/2002 and (EC) No 1702/2003 and issued to:

**Onboard Systems**  
13915 NW 3rd Court,  
Vancouver,  
WA 98685,  
USA

certifies that the change in the type design for the product listed below with the limitations and conditions specified meets the applicable type certification basis and environmental protection requirements when operated within the conditions and limitations specified below:

**Original Product Type Certificate number:** *FAA TC No. H2SW*

**Manufacturer:** *Bell Helicopter*

**Model:** *Bell Model 206L, 206L1, 206L3, 206L4 and 407*

**Description of Design Change:**

Fabrication, Installation and Inspection on Onboard Systems Model 200-258-00 (without load weigh) or Model 200-259-00 (with load weigh) Cargo Hook System per FAA STC SR00898SE.



**European Aviation Safety Agency**

**Associated Technical Documentation:**

- Owner's Manual No. 120-092-00, Revision 2 dated 10, October 2001.
- Instructions for Continued Airworthiness No. 123-007-00, Revision 2, dated 10 October 2003.
- Service Manual Document No. 122-005-00, Revision 7 dated 10, October 2003.
- Master Drawing List No. 155-058-00 Revision 2, dated 10 October 2003.
- Rotorcraft Flight Manual Supplement No. 121-003-00, dated 26 March 2001.

**Limitations and Conditions:**

1. This Cargo Hook System P/N 200-258-00 (without load weight), 200-259-00 (with load weight) or 200-259-01 (with load weight and 5V lighting) are to be fabricated in accordance with FAA approved Onboard Systems Master Drawing List No. 155-058-00, dated 24, January 2001.
2. Approval of this change in Type Design applies to Bell 206L, 206L1, 206L3, 206L4 and 407 rotorcraft which were previously equipped with an FAA approved installation of the Bell Auxiliary Equipment Kit-Cargo Hook Provisions, P/N 206-706-341-7; -9; -103; -11 and, -113 only.
3. Modified Rotorcraft must be operated in accordance with an FAA approved Onboard Systems RFMS.
4. Basis of certification as defined in the applicable Type Certificate Data Sheet.
5. This STC is approved only for the product configuration as defined in the approved design data referred to in the paragraph "Description". Compatibility with other aircraft/engine configurations shall be determined by the installer.

This certificate shall remain valid unless otherwise surrendered or revoked.

For the European Aviation Safety Agency,  
Date of Issue: 1 March 2005

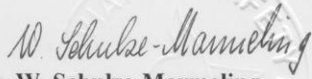
  
**W. Schulze-Marmeling**  
Head of Programmes Certification

STC- EASA.IM.R.S.00595 - Onboard Systems

## Brazilian Approvals



**MINISTÉRIO DA DEFESA**  
**COMANDO DA AERONÁUTICA**  
**DEPARTAMENTO DE PESQUISAS E DESENVOLVIMENTO**  
**CENTRO TÉCNICO AEROESPACIAL**  
**INSTITUTO DE FOMENTO E COORDENAÇÃO INDUSTRIAL**  
**CERTIFICADO DE HOMOLOGAÇÃO SUPLEMENTAR DE TIPO**  
(Supplemental Type Certificate)

**NÚMERO** 2006S01-23  
(Number)

**Este certificado, emitido com base na Lei nº 7565 "Código Brasileiro de Aeronáutica", de 19 de dezembro de 1986,**  
(This certificate issued in the basis of the Law No. 7565 "Código Brasileiro de Aeronáutica", dated 19 December 1986.)

**é conferido ao (à):** Onboard Systems  
(is granted to:) 13915 NW 3rd Court  
Vancouver, WA 98685  
USA

**por ter a modificação ao projeto de tipo do produto abaixo citado, observadas as limitações e condições**  
(for having the change to the type design of the product mentioned below, with the limitations and conditions thereof as)  
**especificadas, satisfeito aos requisitos de aeronavegabilidade aplicáveis.**  
(specified hereon, met the applicable airworthiness requirements.)

**Produto Original - Número do Certificado de Tipo:** H2SW (FAA)  
(Original Product - Type Certificate No.)

**Fabricante:** Bell  
(Manufacturer:)

**Modelo(s):** 206L, 206L-1, 206L-3 and 206L-4.  
(Model(s):)

**DESCRIÇÃO DA MODIFICAÇÃO AO PROJETO DE TIPO:**  
(Description of Type Design Change:)

Installation of Onboard Systems Model 200-258-00 (without load weigh), 200-259-00 (with load weigh) or 200-259-01 (with load weigh and 5V Lighting) Cargo Hook Suspension System, in accordance with Master Drawing List Nº 155-058-00, Rev. 4, dated 17 Jun. 2005 or later approved revision.

This CHST validates in Brazil the STC # SR00898SE, issued by FAA (USA).

**LIMITAÇÕES E CONDIÇÕES:**  
(Limitations and Conditions:)

See continuation sheet for applicable data.

**DATAS:**  
(Dates of:)

**Do Requerimento:** 02 Nov. 2005  
(Application:)

**Da emissão:** 31 Jan. 2006  
(Issue:)

**Da reemissão:**  
(Reissue:)

  
**GERALDO CURCIO NETO** Ten Cel Av  
Chefe da Divisão de Certificação de Aviação Civil  
(Chief, Divisão de Certificação de Aviação Civil)

  
**LUIZ ALBERTO C. MUNARETTO** Cel Av  
Diretor do Instituto de Fomento e Coordenação Industrial  
(Director, Instituto de Fomento e Coordenação Industrial)

F-400-01B (08.04)

Fl. 01 de 02  
(Sheet) (of)

H.02-2515-0



**MINISTÉRIO DA DEFESA**  
**COMANDO DA AERONÁUTICA**  
**DEPARTAMENTO DE PESQUISAS E DESENVOLVIMENTO**  
**CENTRO TÉCNICO AEROESPACIAL**  
**INSTITUTO DE FOMENTO E COORDENAÇÃO INDUSTRIAL**

Folha de Continuação ao  
(Continuation Sheet to)

**CERTIFICADO DE HOMOLOGAÇÃO SUPLEMENTAR DE TIPO**  
(Supplemental Type Certificate)

**NÚMERO 2006S01-23**  
(Number)

**LIMITAÇÕES E CONDIÇÕES:**  
(Limitations and Conditions.)

- I. The approval of this type design change should not be extended to other rotorcraft of this model on which other previously approved modifications are incorporated unless it is determined by the installer that the relationship between this change and any of those other previously approved modifications, including changes in Type Design, will introduce no adverse effect upon the airworthiness of that rotorcraft.
- II. If the holder agrees to permit another person to use this certificate to alter the product, the holder shall give the other person written evidence of that permission.
- III. Installation of this modification must be performed according to the Owners Manual, Document N° 120-092-00, Rev 3, dated 17 Jun. 2005, including the placard of Onboard System N° 215-190-00, IR, dated 30 Jan. 2006.
- IV. Operation must be performed in accordance with FAA Approved Rotorcraft Flight Manual Supplement, document No. 121-003-00, Rev. 1, dated 09 Sep. 2004, or later approved revision.
- V. Maintenance of this installation must be performed in accordance with Instructions for Continued Airworthiness, document N° 123-007-00, Rev. 3, dated 09 May 2005, and Service Manual, document N° 122-005-00, Rev. 8, dated 30 Jun. 2005, or later approved revisions.
- VI. A copy of this Certificate and the Supplement referred on item IV above shall be maintained as part of the permanent records of the modified rotorcraft.

----- END -----

  
F-400-01B (08.04)

  
Fl. 02 de 02  
(Sheet) (of)

H.02-2515-0

**Brazilian Approvals** continued



**MINISTÉRIO DA DEFESA**  
**COMANDO DA AERONÁUTICA**  
**DEPARTAMENTO DE PESQUISAS E DESENVOLVIMENTO**  
**CENTRO TÉCNICO AEROESPACIAL**  
**INSTITUTO DE FOMENTO E COORDENAÇÃO INDUSTRIAL**

**CERTIFICADO DE HOMOLOGAÇÃO SUPLEMENTAR DE TIPO**  
(Supplemental Type Certificate)

**NÚMERO**      **2006S01-24**  
(Number)

**Este certificado, emitido com base na Lei nº 7565 "Código Brasileiro de Aeronáutica", de 19 de dezembro de 1986,**  
(This certificate, issued in the basis of the Law No. 7565 "Codigo Brasileiro de Aeronautica", dated 19 December 1986,

**é conferido ao (à):** Onboard Systems  
(is granted to:) 13915 NW 3rd Court  
Vancouver, WA 98685  
USA

**por ter a modificação ao projeto de tipo do produto abaixo citado, observadas as limitações e condições**  
(for having the change to the type design of the product mentioned below, with the limitations and conditions therefor as)  
**especificadas, satisfeito aos requisitos de aeronavegabilidade aplicáveis.**  
(specified hereon, met the applicable airworthiness requirements.)

**Produto Original - Número do Certificado de Tipo:** 9603 (CTA)  
(Original Product - Type Certificate No:)

**Fabricante:** Bell  
(Manufacturer:)

**Modelo(s):** 407.  
(Model(s):)

**DESCRIÇÃO DA MODIFICAÇÃO AO PROJETO DE TIPO:**  
(Description of Type Design Change:)

Installation of Onboard Systems Model 200-258-00 (without load weigh), 200-259-00 (with load weigh) or 200-259-01 (with load weigh and 5V Lighting) Cargo Hook Suspension System, in accordance with Master Drawing List Nº 155-058-00, Rev. 4, dated 17 Jun. 2005, or later approved revision.

This CHST validates in Brazil the STC # SR00898SE, issued by FAA (USA).

**LIMITAÇÕES E CONDIÇÕES:**  
(Limitations and Conditions:)

See continuation sheet for applicable data.

**DATAS:**  
(Dates of:)

**Do Requerimento:** 02 Nov. 2005  
(Application)

**Da emissão:** 31 Jan. 2006  
(Issue)

**Da reemissão:**  
(Reissue)

  
**GERALDO CURCIO NETO** Ten Cel Av  
Chefe da Divisão de Certificação de Aviação Civil  
(Chief, Divisão de Certificação de Aviação Civil)

  
**LUIZ ALBERTO C. MUNARETTO** Cel Av  
Diretor do Instituto de Fomento e Coordenação Industrial  
(Director, Instituto de Fomento e Coordenação Industrial)

F-400-01B (08.04)

Fl. 01 de 02  
(Sheet) (of)

H.02-2516-0



**MINISTÉRIO DA DEFESA**  
COMANDO DA AERONÁUTICA  
DEPARTAMENTO DE PESQUISAS E DESENVOLVIMENTO  
CENTRO TÉCNICO AEROESPACIAL  
INSTITUTO DE FOMENTO E COORDENAÇÃO INDUSTRIAL

Folha de Continuação ao  
(Continuation Sheet to)

**CERTIFICADO DE HOMOLOGAÇÃO SUPLEMENTAR DE TIPO**  
(Supplemental Type Certificate)

**NÚMERO 2006S01-24**  
(Number)

**LIMITAÇÕES E CONDIÇÕES:**  
(Limitations and Conditions)

- I. The approval of this type design change should not be extended to other rotorcraft of this model on which other previously approved modifications are incorporated unless it is determined by the installer that the relationship between this change and any of those other previously approved modifications, including changes in Type Design, will introduce no adverse effect upon the airworthiness of that rotorcraft.
- II. If the holder agrees to permit another person to use this certificate to alter the product, the holder shall give the other person written evidence of that permission.
- III. Installation of this modification must be performed according to the Owners Manual, Document N° 120-092-00, Rev 3, dated 17 Jun. 2005, including the placard of Onboard System n° 215-190-00, IR, dated 30 Jan. 2006.
- IV. Operation must be performed in accordance with FAA Approved Rotorcraft Flight Manual Supplement, document No. 121-003-00, Rev. 1, dated 09 Sep. 2004, or later approved revision.
- V. Maintenance of this installation must be performed in accordance with Instructions for Continued Airworthiness, document N° 123-007-00, Rev. 3, dated 09 May 2005, and Service Manual, document N° 122-005-00, Rev. 8, dated 30 Jun. 2005, or later approved revisions.
- VI. A copy of this Certificate and the Supplement referred on item IV above shall be maintained as part of the permanent records of the modified rotorcraft.

----- END -----

F-400-01B (08.04)

Fl. 02 de 02  
(Sheet) (of)

H.02-2516-0