

**PLEASE CHECK WEB SITE AT WWW.ONBOARDSYSTEMS.COM FOR
THE LATEST REVISION OF THIS MANUAL**

Owner's Manual
for the
**Cargo Hook Sling
Suspension System**
for the
AS350 Series

System Part Number
200-282-03

*Owner's Manual Number 120-105-01
Revision 2
July 26, 2013*



13915 NW 3rd Court Vancouver, Washington 98685 USA
Phone: 360-546-3072 Fax: 360-546-3073 Toll Free 800-275-0883
www.onboardsystems.com

This page intentionally left blank.

Record of Revisions

<i>Revision</i>	<i>Date</i>	<i>Page(s)</i>	<i>Reason for Revision</i>
0	10/08/09	All	Initial Release
1	02/07/12	All	Corrected system weights, updated safety labels to current format and updated electrical schematic to reflect current Eurocopter configurations.
2	07/26/13	2-11, 2-12, 4-4 & 6-6	Changed Load Cell 210-203-00 to 210-203-03. Changed rigging cautions to warnings. Updated electrical schematic to reflect current aircraft electrical interface, updated instructions related to connecting to aircraft electrical interface.

Register Your Products for Automatic Notifications

Onboard Systems offers a free notification service via fax or email for product alerts and documentation updates. By registering your Onboard Systems products at our website, we will be able to contact you if a service bulletin is issued, or if the documentation is updated.

You can choose to receive notices on an immediate, weekly, or monthly schedule via fax, email or both methods. There is no charge for this service. Please visit our website at www.onboardsystems.com/notify.php to get started.

This page intentionally left blank.

CONTENTS

Section 1

General Information

Introduction, 1-1
Warnings, cautions & notes, 1-1
Specifications, 1-2
Inspection, 1-2
Bill of Materials, 1-3
Theory of Operation, 1-5

Section 2

Installation Instructions

Fixed Manual Release Cable Assembly Installation, 2-1
Cockpit Indicator Installation, 2-6
Electrical Wiring Installation, 2-8
Sling Suspension Installation, 2-13
Removable Manual Release Cable Assembly Installation, 2-14
External Electrical Release and Load Cell Cable Installation, 2-17
Placard Installation, 2-18
Installation Check-Out, 2-18
Component Weights, 2-19
Paper Work, 2-19

Section 3

Load Weigh Systems Operation Instructions

Indicator Front Panel, 3-1
The Run Mode, 3-2
 To Zero or Tare the Display, 3-3
 To Un-Zero the Display, 3-3
 Error Codes, 3-4
The Setup Mode, 3-5
 Indicator Dampening, 3-7
 To look at, or change the dampening level, 3-7
 Indicator Calibration, 3-8
 To look at or change the calibration code, 3-8
 Installation Zero, 3-9
 To run the installation zero routine, 3-9
 Calibration by Lifting a Known Weight, 3-9
 To run calibration by known weight routine, 3-10
 Setting the Scale on a Remote Analog Meter, 3-11
 To look at or change the scale, 3-11
 Select KG or LB Units, 3-12
 To look at or change the units, 3-12
 Indicator Version, 3-13

CONTENTS, continued

Section 4 Operation Instructions

Operating Procedures, 4-1
Disconnecting Removable Provisions, 4-2
Cargo Hook Loading, 4-3
Cargo Hook Rigging, 4-4

Section 5 Maintenance

Instructions for Returning Equipment to the Factory, 5-1

Section 6 System Part Numbers

210-204-00 AS 350 Sling Fixed Provisions, 6-1
210-206-01 AS 350 Sling Removable Provisions, 6-2
232-150-00 Release Handle Assembly, 6-3
232-151-00 Quick Disconnect Support assembly, 6-4
232-144-00 Sling Gimbal Sub-Assembly, 6-5
232-435-00 Cargo Hook Sling Assembly, 6-6

Section 7 Certification

FAA STC, 7-1
Canadian Approval, 7-3
EASA STC, 7-4

Section 1

General Information

Introduction

The 200-282-03 Cargo Hook Sling Suspension System kit consists of fixed provisions (P/N 210-204-00) and removable provisions (P/N 210-206-01). The fixed provisions are permanently installed on the aircraft while the removable provisions are easily removed when not required on the helicopter's mission.

These kits are approved for installation on Eurocopter AS350B, AS350BA, AS350D, AS350B1, AS350B2, and AS350B3 helicopters.

Safety Labels

The following definitions apply to safety labels used in this manual.



Indicates a hazardous situation which, if not avoided, will result in death or serious injury.



Indicates a hazardous situation which, if not avoided, could result in death or serious injury.



Indicates a hazardous situation which, if not avoided, could result in minor or moderate injury.



Draws the reader's attention to important or unusual information not directly related to safety.



Used to address practices not related to personal injury.

Specifications

Table 1-1 Suspension System Specifications

Design load	1,660 lb. (750 kg.)
Design ultimate strength	6,225 lb. (2823 kg.)
Unit weight, Fixed Provisions	3.7 lbs (1.68 kg.)
Unit weight, Removable Provisions	5.0 lbs (2.27 kg.)

Table 1-2 P/N 528-029-00 Cargo Hook Specifications

Design load	3,600 lb. (1,633 kg.)
Design ultimate strength	13,500 lb. (6,123 kg.)
Electrical release capacity	9,000 lb. (4,082 kg.)
Mechanical release capacity	9,000 lb. (4,082 kg.)
Force required for mechanical release at 3,600 lb.	8 lb. max. (.600" travel)
Electrical requirements	22-32 VDC 6.9 – 10 amps
Minimum release load	0 pounds
Unit weight	3.0 pounds (1.35 kg.)
Mating electrical connector	PC06A8-2S SR



Load capacities given are for the equipment described only. Loading limits for your particular helicopter model still apply. Consult your flight manual.

Inspection

Inspect the kit items for evidence of damage, corrosion and security of lock wire and fasteners. If damage is evident, do not use the items until they are repaired.

Bill of Materials

The following items are included with the 200-282-03 Sling Suspension System, the 210-204-00 fixed provisions, or the 210-206-01 removable provisions. If shortages are found contact the company from whom the system was purchased.

Table 1-3 Onboard Systems Bill of Materials

Part Number	Description	200-282-03 Qty	210-204-00 Qty	210-206-01 Qty
120-105-01	Owner's Manual	1	1	1
121-013-01	RFMS	1	1	1
122-017-00	Cargo Hook Service Manual	1	-	1
123-012-01	ICA Manual	1	1	1
210-095-00	C-39 indicator Assembly	1	1	-
215-165-00	Multiple Decal Sheet	1	1	-
215-167-00	Max Hook Load 1660 Decal	1	-	1
232-435-00	Cargo Hook Sling Assembly	1	-	1
232-150-00	Release Handle Assembly	1	1	-
232-151-00	Quick Disconnect Support Assembly	1	1	-
268-024-02	Manual Release Cable Assembly	1	-	1
270-106-02	Load Weigh Internal Harness	1	1	-
270-108-00	Electrical Release Internal Harness	1	1	-
270-110-01	Electrical Release Cable Assembly	1	-	1
290-772-00	Indicator Mount Bracket	1	1	-
290-781-00	Cable Support Bracket	1	1	-
290-782-00	Connector Bracket	1	1	-
290-783-00	Relay Bracket	1	1	-
445-005-00	Relay	1	1	-
500-065-00	Grommet Edging	1	1	-
510-029-00	Nut	8	8	-
510-042-00	Washer	3	3	-
510-062-00	Washer	8	8	-
510-085-00	Washer	3	3	-
510-095-00	Washer	3	3	-
510-102-00	Nut	5	5	-
510-277-00	Screw	2	2	-
510-278-00	Washer	2	2	-
510-279-00	Nut	2	2	-
510-453-00	Bolt	3	3	-
510-455-00	Bolt	2	2	-
510-457-00	Screw	4	4	-
510-475-00	Screw	3	3	-
510-481-00	Screw	8	8	-
512-024-00	Adel Clamp	2	2	-

Bill of Materials continued

To complete the cargo hook installation the following Eurocopter parts may be necessary to obtain (these parts are frequently found to be on the aircraft or are standard Eurocopter parts).



These items may or may not be installed with a standard aircraft, therefore verification is recommended before purchasing them.

Table 1-4 Eurocopter Parts

Eurocopter P/N	Onboard P/N	Description	Qty
DHS751-160.62	610-007-00	Grommet	1
SL211M5-1	610-009-00	Nut	3
A3125-2 H179	610-011-00	Quick Disconnect Clamp	2
350A86-0020-33	610-016-00	Bracket	1
ASNA0078A403	610-019-00	Rivet	3

The cargo hook electrical system interfaces with the aircraft's electrical panel. Earlier versions (pre-mod. #07-3274) of the AS350 utilize a fuse type switch panel. The following electrical panel components for these versions are typically found to be on the aircraft, but may be necessary to obtain.

Table 1.5 Eurocopter Electrical Parts – Pre-mod. #07-3274

Eurocopter P/N	Onboard P/N	Description	Qty
DHS775-160-42	610-012-00	Indicator Light Body	1
DHS775-240-22	610-013-00	Indicator Light	1
EN2240-6839	610-014-00	Lamp	4
D1-2-5	610-017-00	Fuse 2.5A	1
DA8-16A	610-018-00	Fuse 16A	1

AS350B2 and B3 aircraft with modification #07-3274 incorporated utilize a circuit breaker type switch panel. The following electrical panel components for these versions are typically found to be on the aircraft, but may be necessary to obtain.

Table 1.6 Eurocopter Electrical Parts – with Mod. #07-3274

Eurocopter P/N	Onboard P/N	Description	Qty
045004A127A	610-027-00	Cargo Hook Sling Switch	1
ECS0744A02A5	610-028-00	Circuit Breaker 2.5A	1
ECS0744B15A0	610-029-00	Circuit Breaker 15A	1

Theory of Operation

The 200-282-03 Cargo Hook Sling Suspension System is comprised of:

- A gimbaled suspension with load cell that supports the cargo hook.
- An electrical release system that provides means for release by pilot actuation of the push-button switch in the cockpit. When the push-button switch is pressed, it energizes the DC solenoid in the cargo hook, and the solenoid opens the latch in the internal mechanism.
- A manual release system, which provides a means of releasing a cargo hook load in the event of an electrical release system failure. A lever mounted to the collective stick actuates it.
- Ground personnel may also release a load by the actuation of a lever located on the side of the cargo hook.
- A load weigh system, which is comprised of an Indicator mounted to the RH door pillar within the cockpit connected to a load cell between the cargo hook and frame.

A load is attached to the cargo hook by passing a cargo sling ring into the throat of the load beam and pushing the ring against the upper portion of the load beam throat, which will cause the hook to close. In the closed position, a latch engages the load beam and latches it in this position. To release the load, the latch is disengaged from the load beam. With the latch disengaged, the weight of the load causes the load beam to swing to its open position, and the cargo sling ring slides off the load beam. The load beam then remains in the open position awaiting the next load.

This page intentionally left blank.

Section 2

Installation Instructions

These procedures are provided for the benefit of experienced aircraft maintenance facilities capable of carrying out the procedures. They must not be attempted by those lacking the necessary expertise.

2.1 Fixed Manual Release Cable Assembly Installation

Remove lower fairings to access areas underneath cabin floor where cable is routed.

The manual release cable installation consists of a fixed section (P/N 268-025-00) and a removable section. The fixed section is routed from the release lever at the collective, aft to a bracket at the forward fuel tank support (as shown in Figure 2.1.1). Figure 2.1.1 is an overview of the cable routing and the figures and instructions following detail the cable support installations at various points.

Figure 2.1.1 Fixed Manual Release Cable Installation Overview

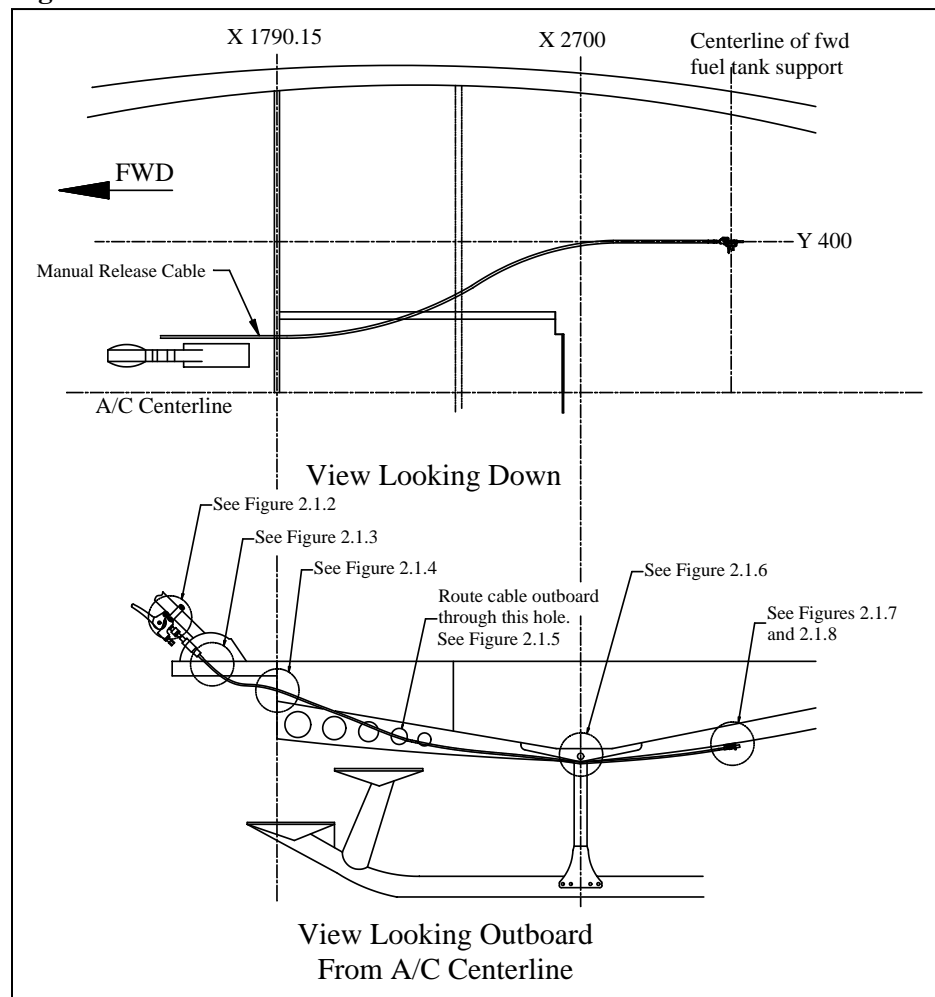

2.1 Fixed Manual Release Cable Assembly Installation continued

- Mount the manual release lever (assembly P/N 232-150-00) to the collective shaft with the Clamp Half (P/N 290-753-00) and two screws (P/N 510-390-00) provided pre-assembled on the release lever assembly, as illustrated below.

Figure 2.1.2 Manual Release Lever Installation

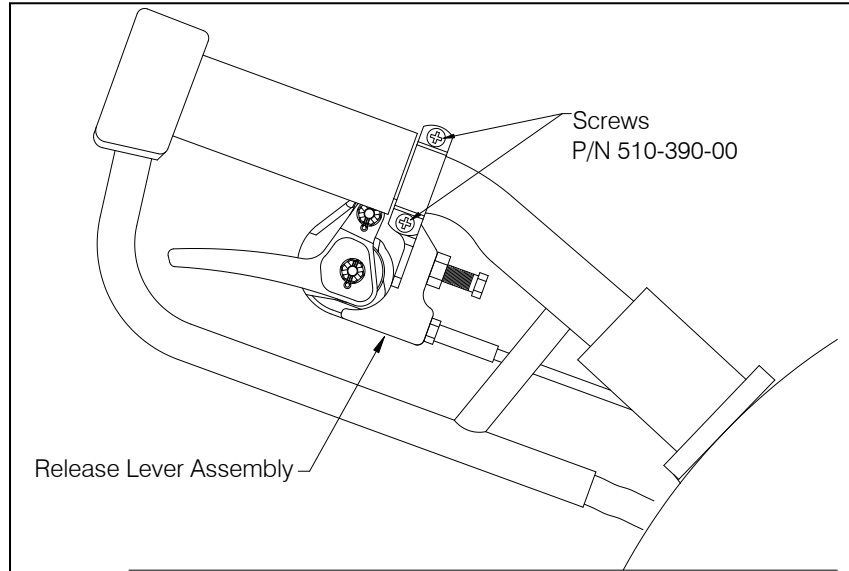

- Route the cable to underneath the cabin floor through the existing slot by removing the grommet to allow the cable end fitting to be fed through. Re-install grommet.

If the slot in the floor does not exist, create one with dimensions as shown below in the cabin floor 43 mm from the collective pitch lever unit and 150 mm forward of X1790.15 (see below) and install the grommet (Eurocopter P/N DG-38).

Figure 2.1.3 Cabin Floor Hole Detail

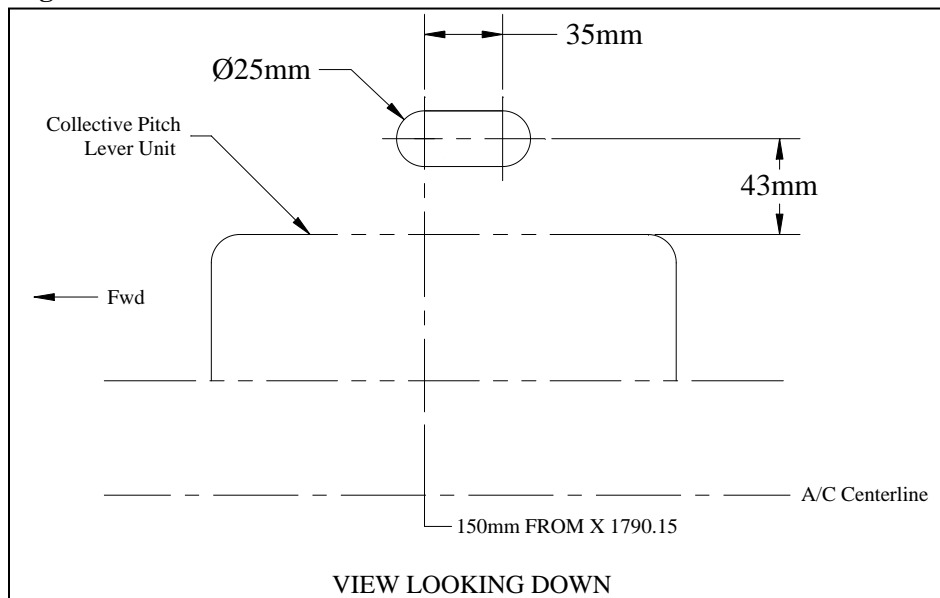

2.1 Fixed Manual Release Cable Assembly Installation continued

- Underneath the floor route the manual release cable through an existing hole in the frame immediately aft of the collective by securing an Adel clamp (P/N 512-024-00) to the existing bracket (Eurocopter P/N 350A86-1051-00) with hardware as illustrated below and routing the cable through it.

Figure 2.1.4 Cable Routing Through Frame

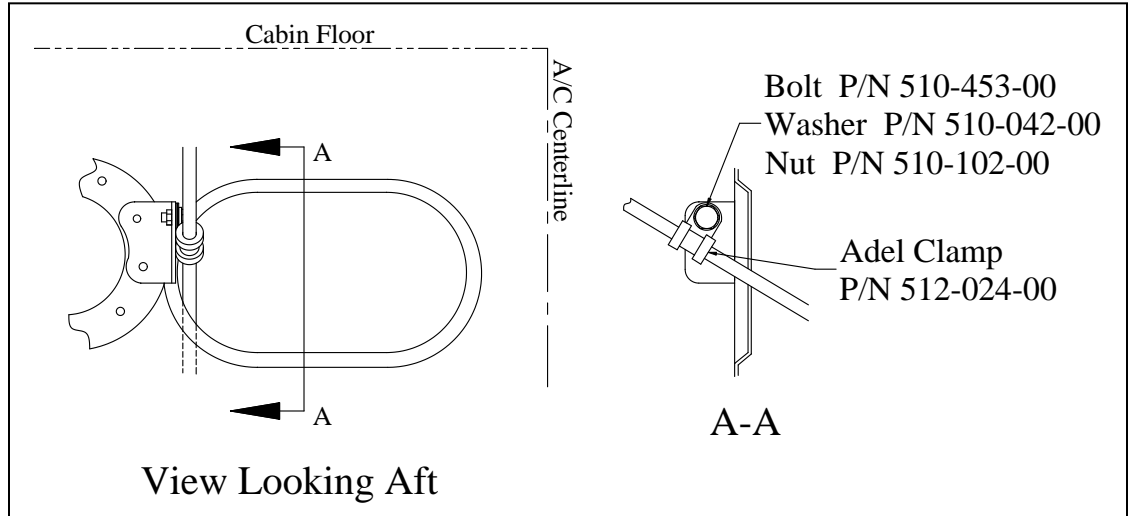

- Aft of the frame, route the cable outboard through the hole in the structural member as shown in Figure 2.1.1 and Figure 2.1.5 and install Plastic Edging Grommet (P/N 500-065-00).

Figure 2.1.5 Grommet Installation

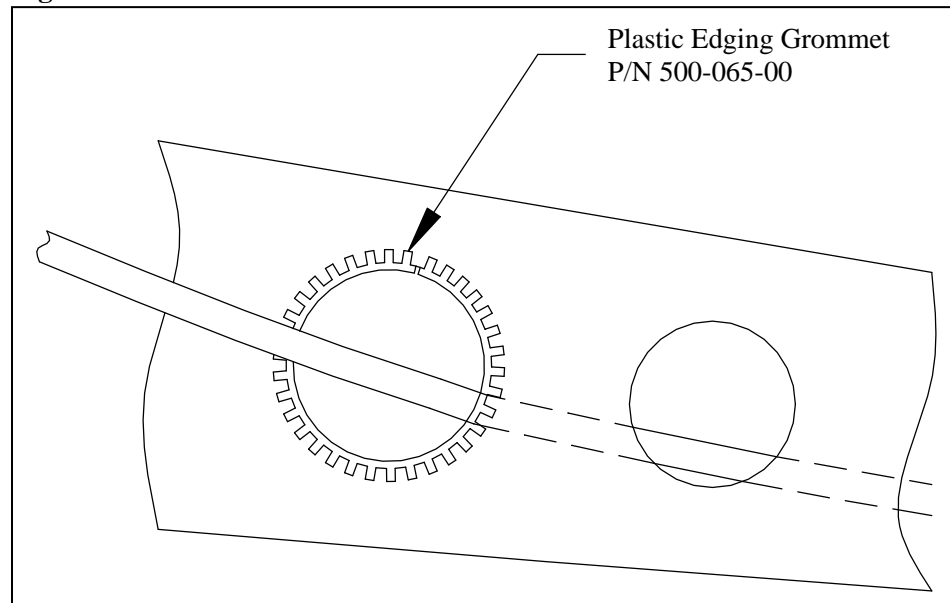

2.1 Fixed Manual Release Cable Assembly Installation continued

- At the inboard side of the RH forward landing gear fitting (X2700) secure Cable Support Bracket (P/N 290-781-00) with hardware as illustrated below. Route release cable through and secure Adel Clamp (P/N 512-024-00) to Cable Support Bracket with hardware as illustrated below.

Figure 2.1.6 Cable Support Bracket Installation

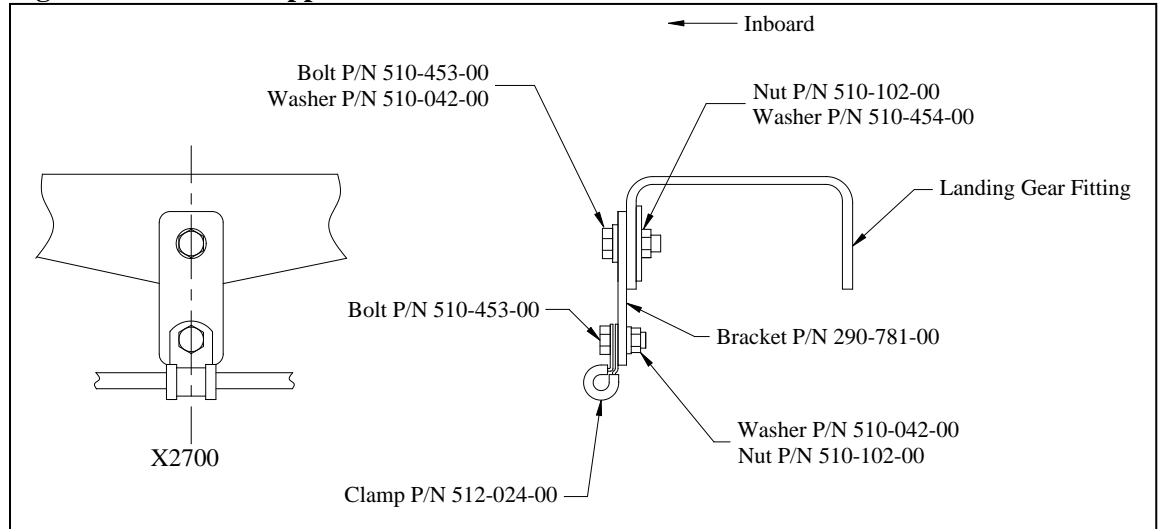

- Install the Quick Disconnect Bracket Assembly (P/N 232-151-00) on the RH rear lower fairing (with fairing removed) at a location 400mm (15.7 in.) to the right of the A/C centerline and in line with the forward fuel tank support (reference Figure 2.1.1) utilizing the existing insert holes in the honeycomb panel structure. Secure with fasteners (provided pre-assembled on bracket) as illustrated below.

NOTICE

If your helicopter does not have holes in the honeycomb panel, modify panel per Eurocopter Service Bulletin No. 25.00.62.

Figure 2.1.7 QD Bracket Installation

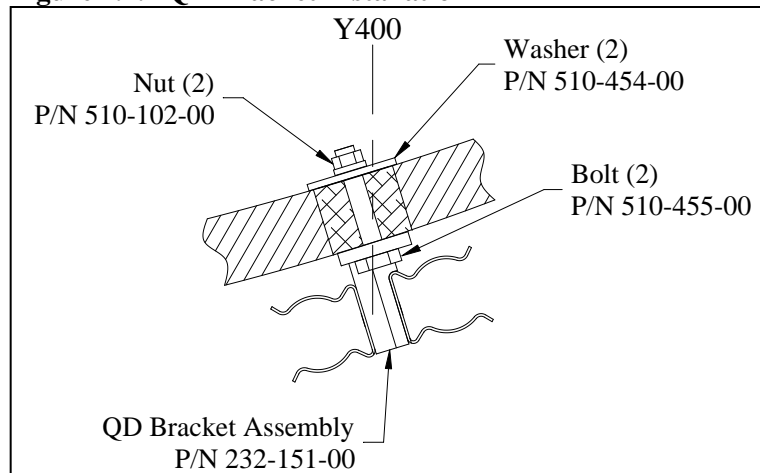

2.1 Fixed Manual Release Cable Assembly Installation continued

- Install the 2 clamps (Eurocopter P/N A3125-2 H179) that will support the removable section of the manual release cable. The clamps are installed at points 1 and 2 (see below) using existing inserts in the belly of the helicopter.

NOTICE

If your helicopter does not have holes in the honeycomb panel, modify panel per Eurocopter Service Bulletin No. 25.00.62.

Figure 2.1.8 Cable Support Clamp Installation

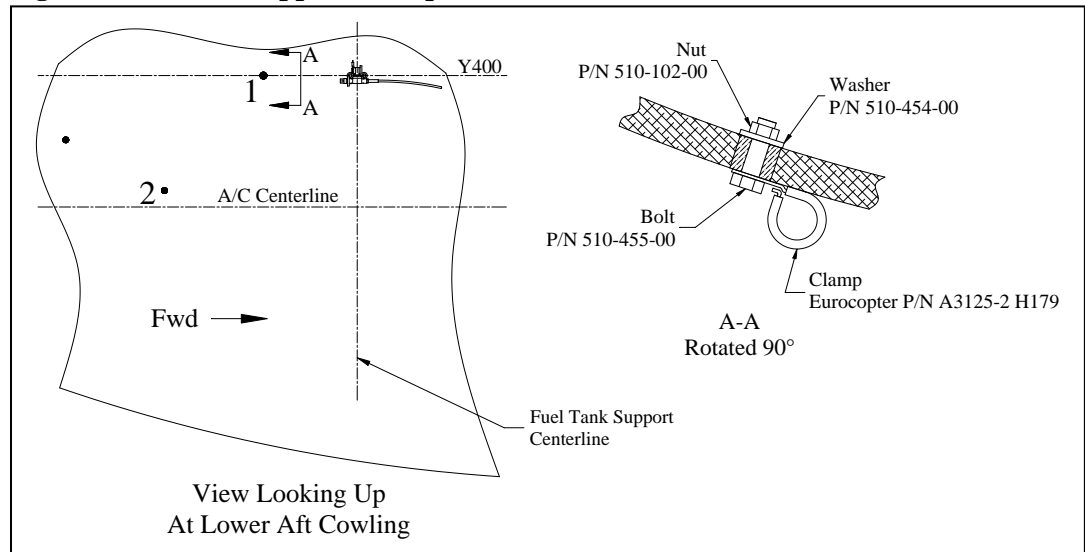

2.2 Cockpit Indicator Installation

The Indicator is mounted on the RH door pillar. If nut clips are not pre-installed in the door pillar, install them per the following.

- Hold the Indicator Bracket (P/N 290-772-00) at location as shown below and transfer its hole pattern to the door pillar.

Figure 2.2.1 Indicator Bracket Installation

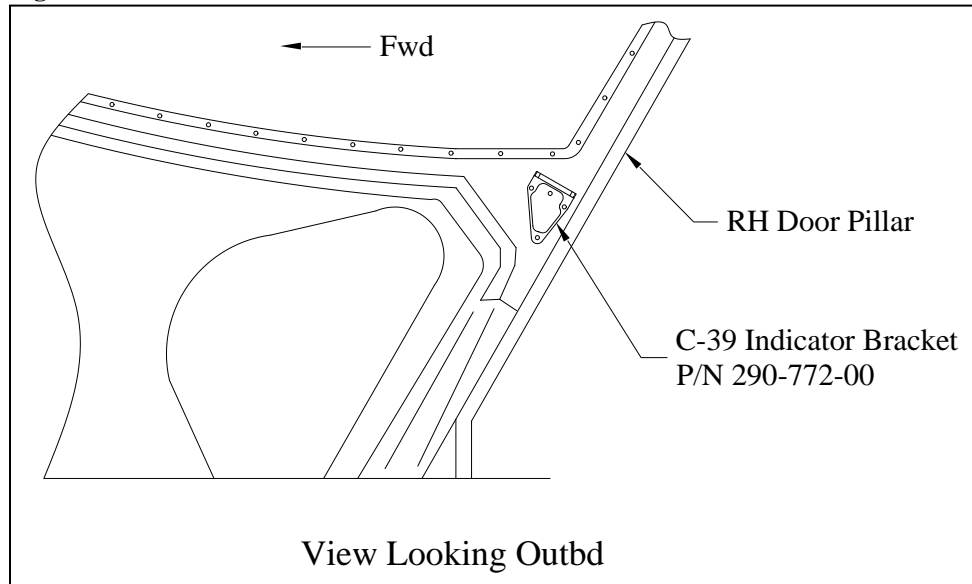

- Drill three mounting holes in the RH door pillar to install the nut clips. Reuse the electrical bonding screw at the fourth location (see below).
- After completing electrical bonding, install the three nut clips (Eurocopter P/N SL211M5-1) and fasten Indicator Bracket with three screws (P/N 510-475-00) and three washers (P/N 510-095-00).

Figure 2.2.2 Indicator Bracket Hardware

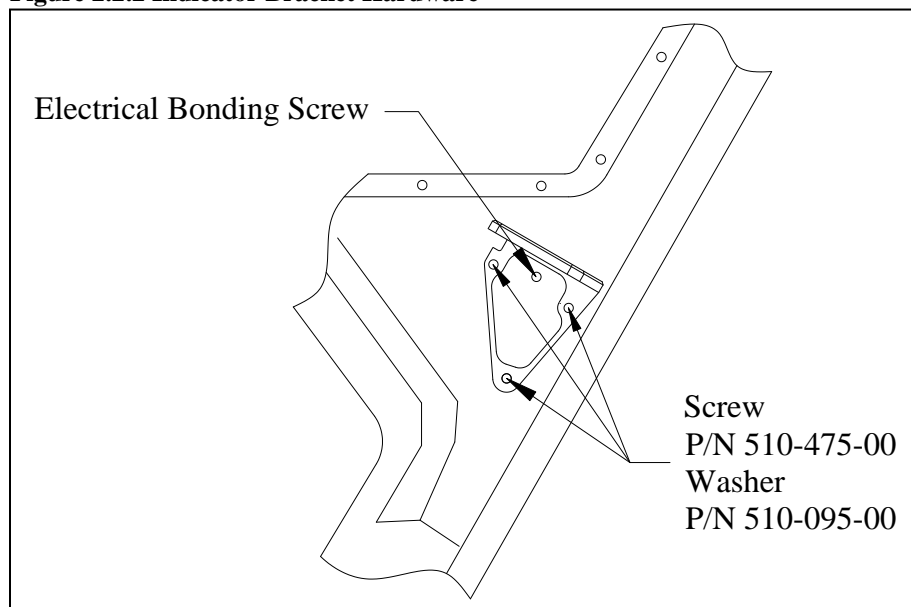

2.2 Cockpit Indicator Installation *continued*

- Install C-39 Indicator (P/N 210-095-00) onto the bracket with hardware as illustrated below.

Figure 2.2.3 C-39 Indicator Installation

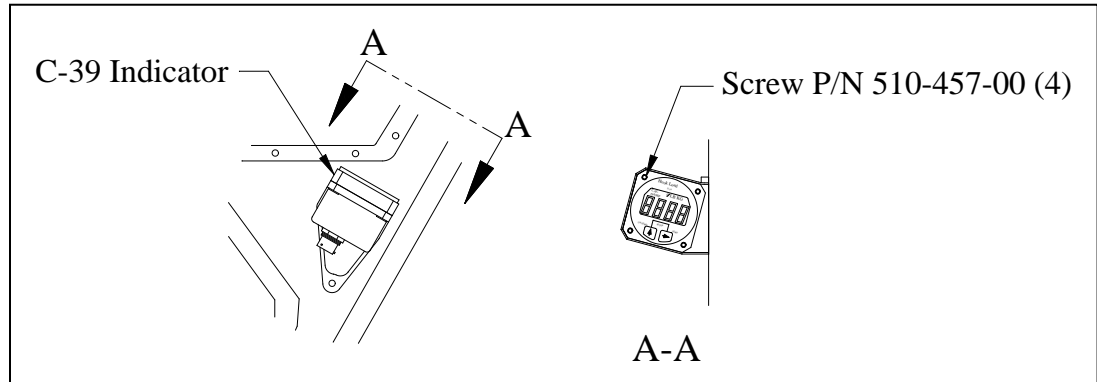

2.3 Electrical Wiring Installation

Install electrical harnesses (P/N 270-106-02 and P/N 270-108-00). Route them along the existing harnesses (reference Figure 2.3.1) while observing the following precautions:

- Pick up existing wire runs by opening existing cable clamps. Nylon ties alone may not be used for primary support.
- The distance between supports should not exceed 21”.
- Bend radius of wire or harness must not be less than 10 times the wire or harness diameter.
- Inspect and verify that the wire harness may not be manually deflected into a structure with a bend radius of less than .13”.

Make the appropriate connections with electrical contacts supplied with kit. Secure the C-39 indicator harness (P/N 270-106-02) along the canopy with clamps and connect the C-39 indicator connector. Refer to Figure 2.3.6 for electrical schematic.

The electrical harness includes a line that can be equipped with an accessory connector for use with an Onboard Systems Data Recorder or Analog Meter. These items are not included under this STC. If the accessory line is not used, stow this line of the harness.

Figure 2.3.1 Electrical Wiring Routing Overview

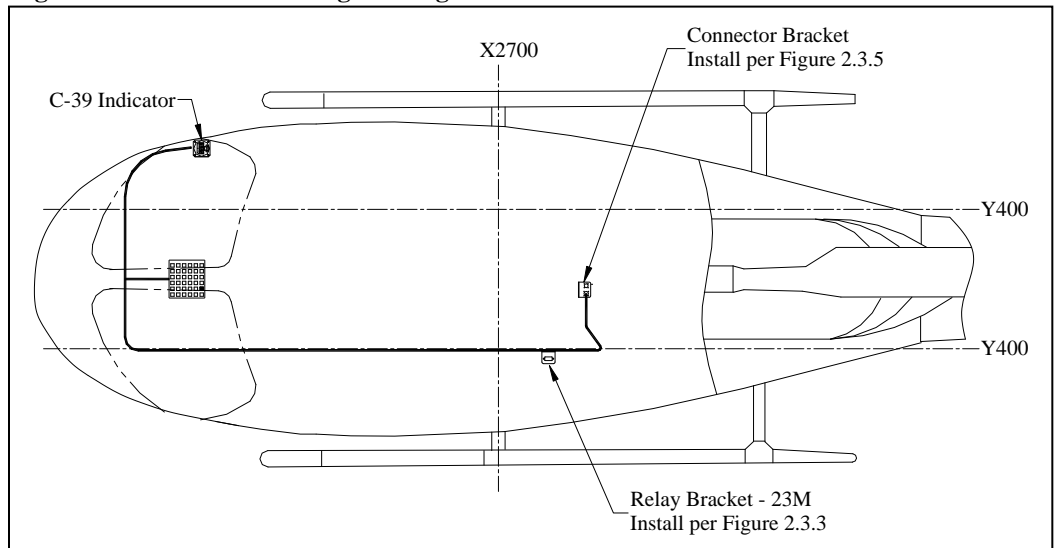

2.3 Electrical Wiring Installation continued

If installing the wire harnesses on a newer AS350B2 or B3 model equipped with a switch panel of circuit breaker design (Eurocopter mod. #07-3274 incorporated) the electrical harness P/N 270-108-00 requires minor modification as follows. Cut the ME1E wire off just prior to the butt splice and discard the splice and the 20 ga. wires.

Figure 2.3.2 P/N 270-108-00 Harness Modification

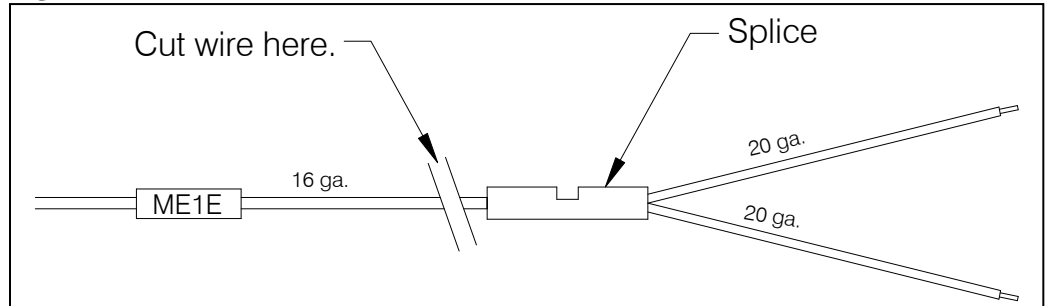

- Create two holes for the Relay Bracket (P/N 290-783-00) in the LH beam at Y400 as illustrated in Figure 2.3.3.

Figure 2.3.3 Relay Bracket Installation

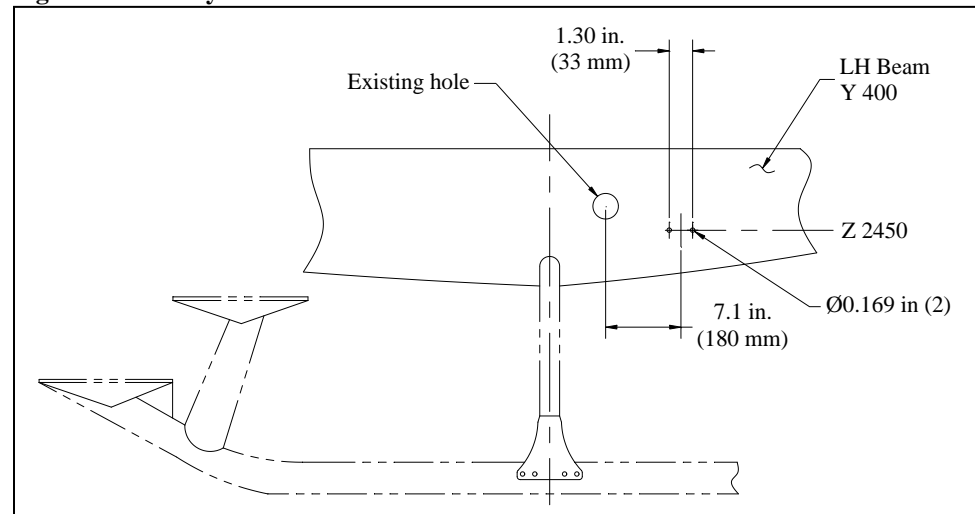

- Secure Relay Bracket with two screws (P/N 510-277-00), washers (P/N 510-278-00), and nuts (P/N 510-279-00).
- Place relay socket (part of 270-108-00 electrical harness) into relay bracket mounting holes from below and secure to relay and Relay Bracket with hardware provided with relay (as illustrated below).

2.3 Electrical Wiring Installation continued

Figure 2.3.4 Relay Installation

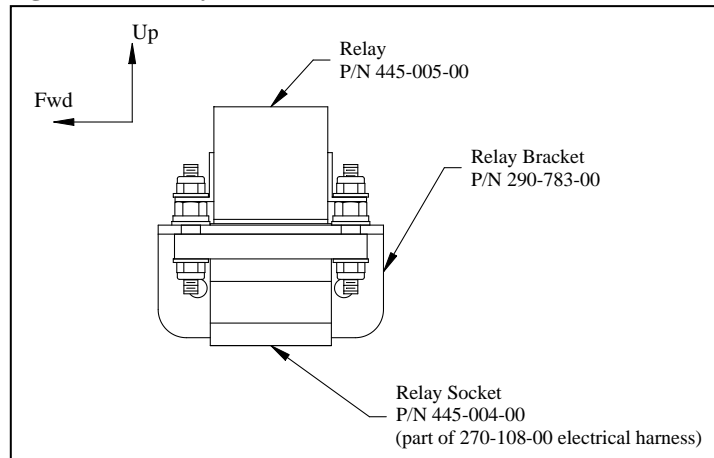

- Locate Connector Bracket at forward fuel tank support as shown below and drill support frame for rivets (Eurocopter P/N ASNA0078A403) to match its hole pattern.
- Drill out pilot holes in Connector Bracket for rivets.
- Fasten hook release connector (32M) and load cell connector (55M) to the Connector Bracket with screws (P/N 510-481-00), washers (P/N 510-062-00), and nuts (P/N 510-029-00).

NOTICE

Install screws with their heads on the bottom side of bracket flange (if nuts are installed on bottom side they will interfere with mating connector).

Figure 2.3.5 Connector Bracket Installation

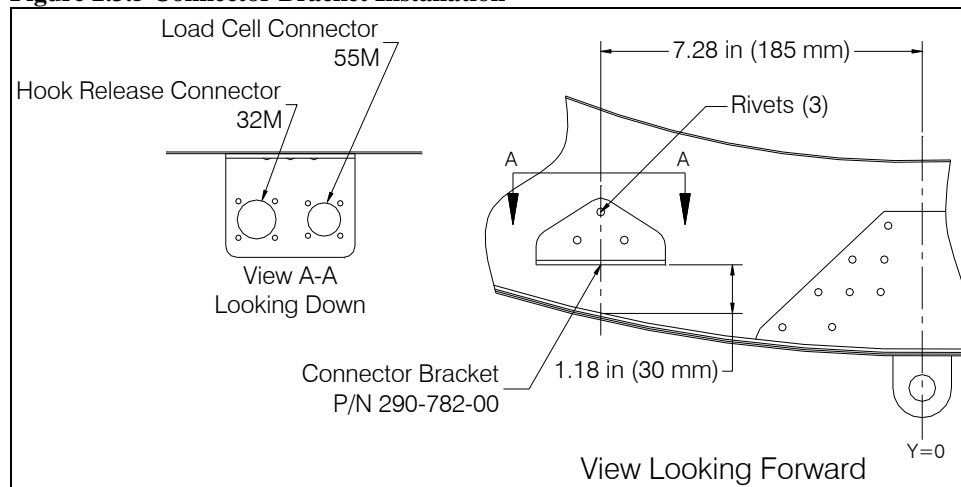

- Install electrical markers (P/N 215-165-00).
- Re-install lower fairings.

2.3 Electrical Wiring Installation continued

The electrical schematic for the electrical release system and the load weigh system is shown below along with the aircraft's interface points. Eurocopter modification #'s 07-4280 and 07-3450 are reflected below. Earlier Eurocopter configurations which affected how and where wire numbers ME1E, ME2E and ME10E of the electrical release harness and load weigh harness interface with the helicopter are shown on the following page. Refer to the applicable Eurocopter Wiring Diagrams Manual for additional information and for other cargo hook aircraft side wiring configurations that may not be shown.

For the C-39 Indicator backlighting, install wire 2LK71E to an available pin in the instrument panel or console lighting circuit (31L for pre-mod 07-4280), at 28 volts the indicator's internal bulb draws 25 mA.

If existing Eurocopter cargo hook or load weigh wiring is installed and terminated at the locations below, remove the wires completely or remove from connectors and cap and stow them.

Figure 2.3.6 Electrical Schematic

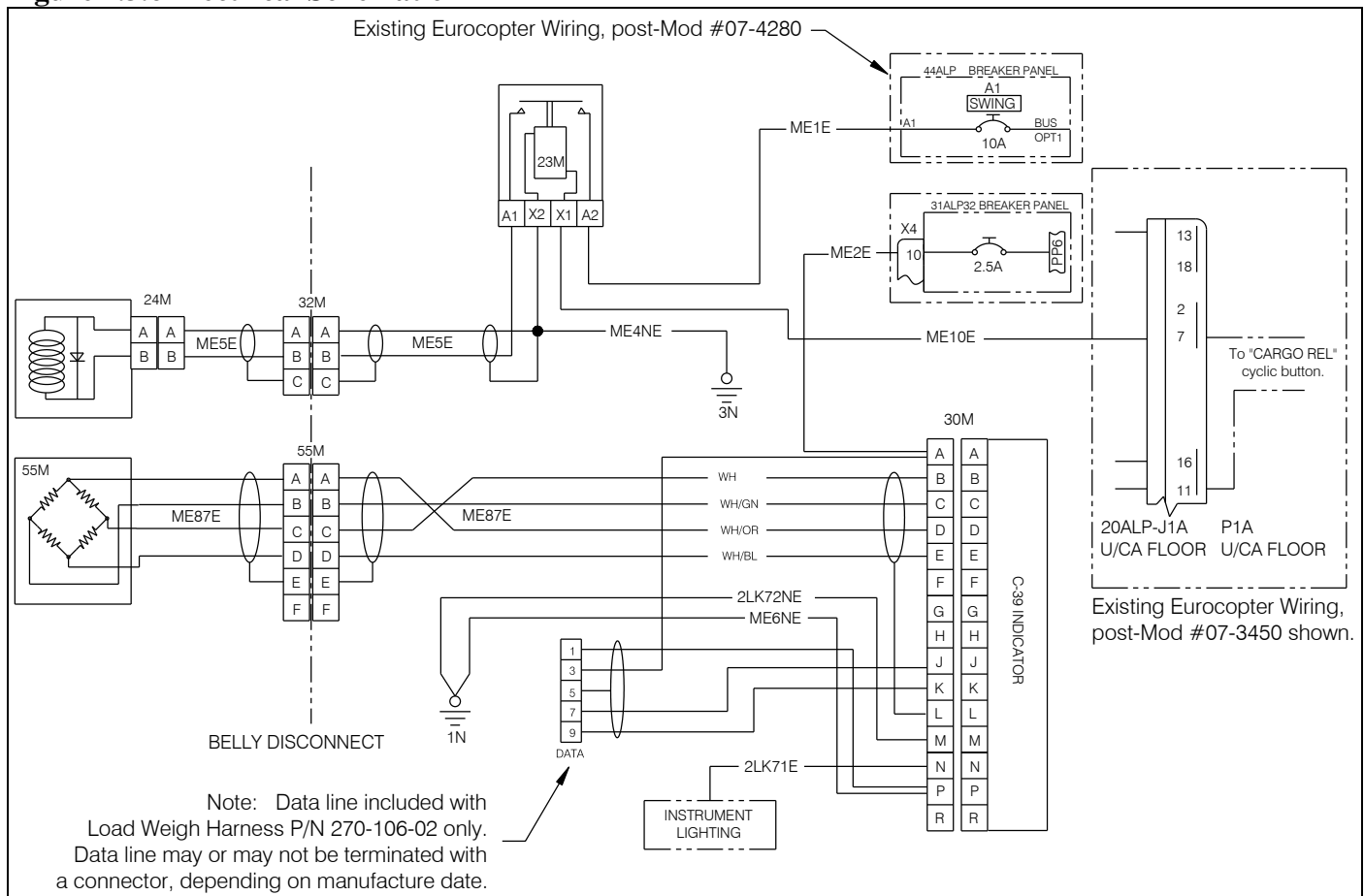

2.3 Electrical Wiring Installation continued

Figure 2.3.6 Electrical Schematic continued

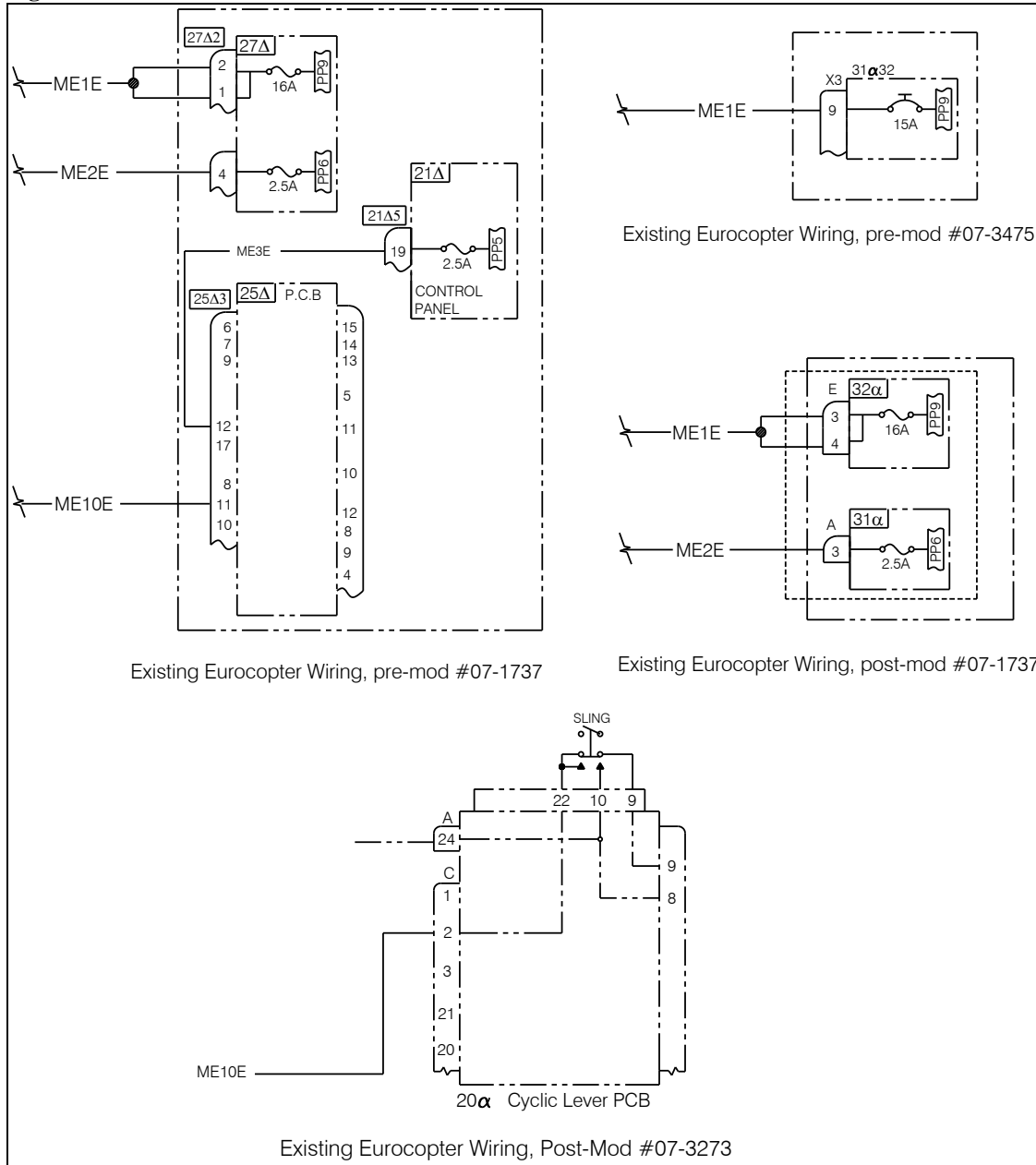

2.4 Sling Suspension Installation

Remove the hardware (shown below) that is pre-assembled onto the Cargo Hook Sling Assembly (P/N 232-435-00). With the cargo hook oriented as shown, attach the Cargo Hook Sling Assembly onto the hard point at the helicopter centerline using the hardware, as illustrated below. Tighten the nut finger tight, then rotate it to the next castellation to install the cotter pin.

Figure 2.4.1 Sling Suspension Installation

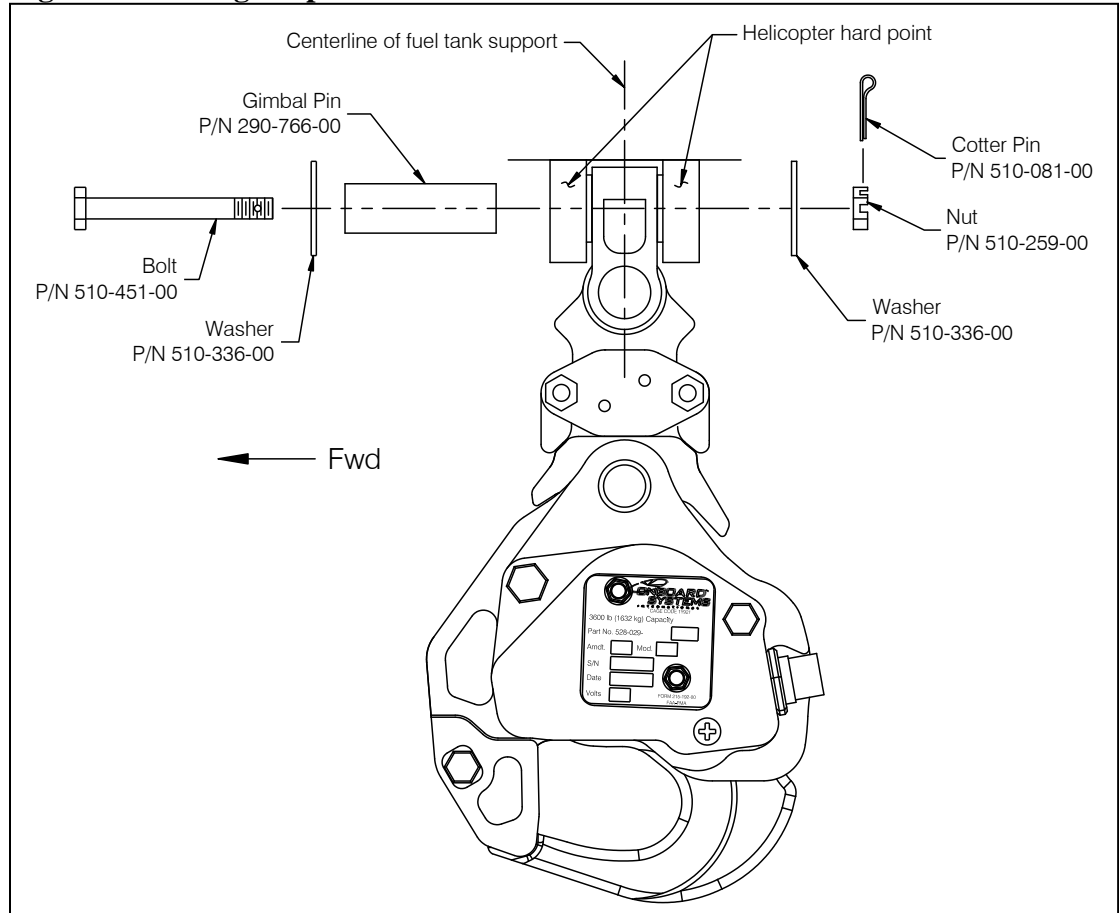

2.5 Removable Manual Release Cable Assembly Installation

Connect the manual release cable (P/N 268-024-02) to the cargo hook per the following instructions:

- Remove the manual release cover from the cargo hook by removing two screws (see below).

Figure 2.5.1 Manual Release Cover Removal

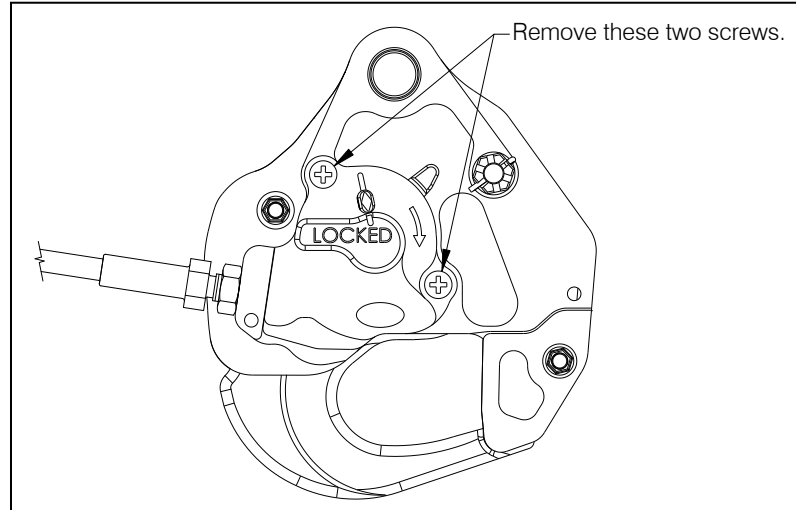

- Thread the fitting at the end of the manual release cable into the manual release boss on the cargo hook side plate until the threads protrude approximately .125 inches beyond the boss and secure with jam nut (as shown in Figure 2.2.2). Leave the manual release cover off of the cargo hook until the other end of the release cable is connected, in order to verify proper setting.

Figure 2.5.2 Initial Release Cable Adjustment

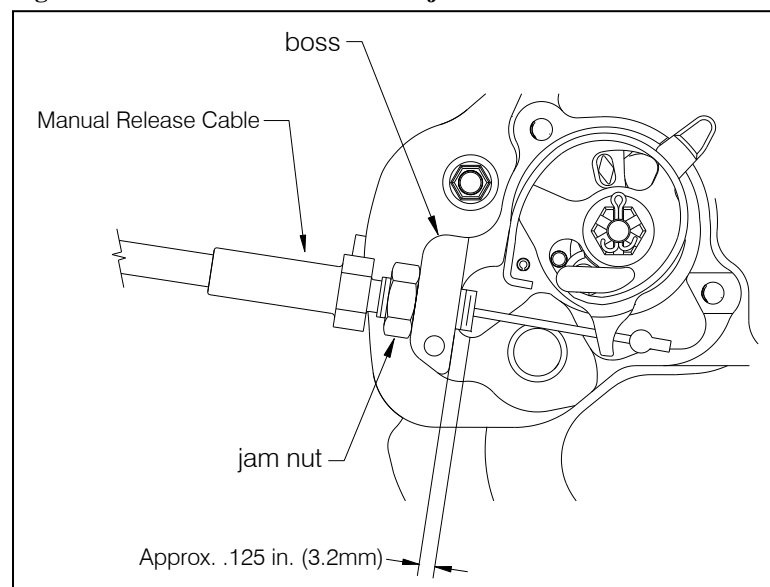

2.5 Removable Manual Release Cable Assembly Installation continued

- Connect the other end of the removable cable assembly to the end of the fixed cable by sliding the Adapter Fitting back to expose the swaged cable end fitting and connecting this fitting to the swaged cable end fitting on the fixed cable as shown below.



The pre-set compressed spring length is set at the factory to be 1.94/2.00 inches (see below). If necessary, minor adjustments may be made at the release handle assembly on the collective.

- Thread the Adapter Fitting on the removable cable onto the fixed cable adapter fitting and lock in position by engaging a castellation with the Locking Pin (P/N 514-052-00).
- Snap the removable cable Adapter Fitting into the inboard spring clip on the Quick Disconnect Support Assembly.

Figure 2.5.3 Manual Release Cable Connection

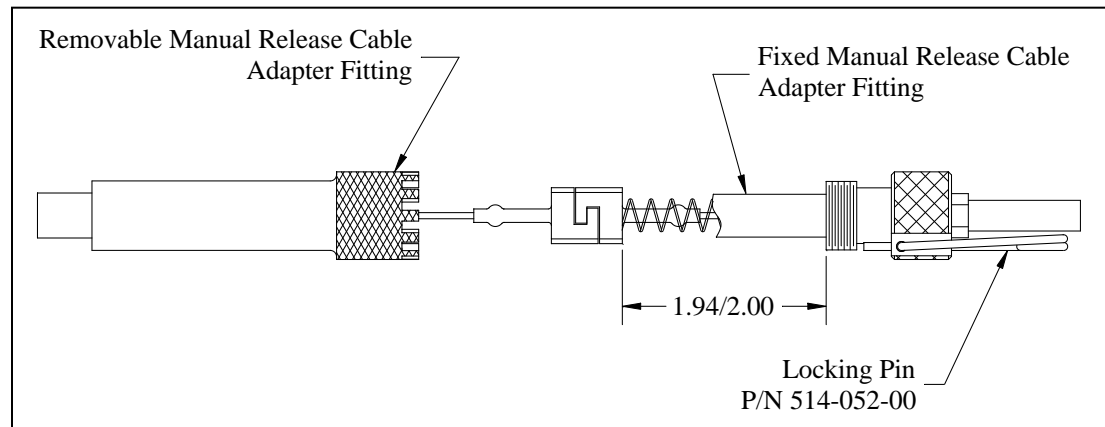

- At the cargo hook, ensure the manual release cable is between the two prongs of the release lever fork as illustrated in Figure 2.5.4.

2.5 Removable Manual Release Cable Assembly Installation continued



Manual release cable rigging must be done with the cargo hook in the closed and locked position.

- With the cargo hook closed and locked, rotate the release lever in the clockwise direction to remove free play (the free play is taken up when the hook lock indicator begins to move, this is also felt as the lever rotates relatively easily for several degrees as the free play is taken up) and measure the gap between the cable ball end and the release lever fork with the manual release lever in the cockpit in the non-release position. This gap should be a minimum of .125 inches (3.2 mm) as shown in Figure 2.5.4.

Figure 2.5.4 Manual Release Cable Rigging

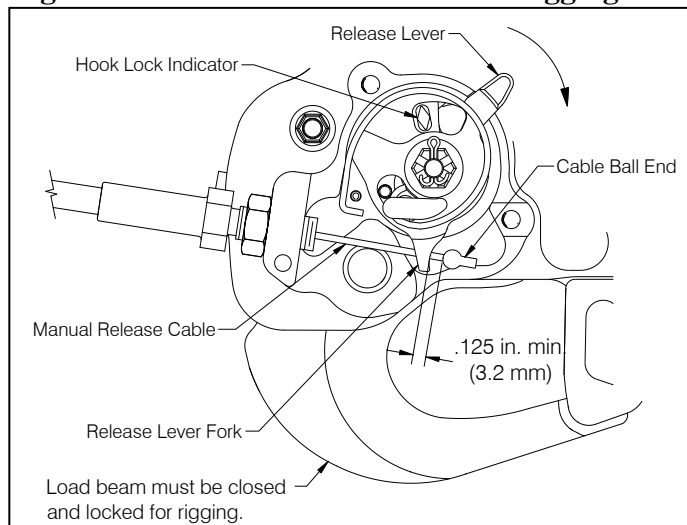

- If necessary adjust the manual release cable system to obtain the minimum gap of .125 inches at the release lever fork as shown in Figure 2.5.4 (the maximum gap is limited by the manual release cover, i.e.- the release cable must fit within the cover when it is installed). The system can be adjusted at the manual release lever on the collective or minor adjustments can be made at the cargo hook by loosening the jam nut and turning the manual release cable in the required direction (this requires that the manual release cable be disconnected from the fixed release cable and the quick release clamps on the belly). Be sure to maintain full thread engagement between the manual release cable fitting and cargo hook.
- Re-install the manual release cover with the two screws and ensure the manual release cable jam nut is tightened securely against the cargo hook.

2.6 External Electrical Release and Load Cell Cable Installation

Connect the appropriate end of the cargo hook electrical release cable (P/N 270-110-01) to the Cargo Hook (24M, ref. Figure 2.3.4) and secure with safety wire. Connect the other end of the cable to the appropriate connector (32M) mounted per section 2.3. See table 2-1 for connector pin out information.

Table 2-1 Cargo Hook Connector

<i>Pin</i>	<i>Function</i>
A	Ground
B	Power

CAUTION

The cargo hook is equipped with a suppression diode that will be damaged if the cargo hook electrical connection is reversed.

Connect the electrical cable from the load cell (55M) cable to the appropriate connector (55M) mounted per section 2.3.

! WARNING

Un-commanded cargo hook release will happen if the manual release cable is improperly restrained. The cable must not be the stops that prevent the Cargo Hook from swinging freely in all directions. If the Cargo Hook loads cause the hook to strain against the manual release cable the swaged end of the cable may separate allowing the inner cable to activate the cargo hook manual release mechanism. The result is an un-commanded release. Ensure that no combination of cyclic stick or Cargo Hook position is restrained by the manual release cable.

Figure 2.6.1 Un-commanded Release From Incorrectly Secured Cable

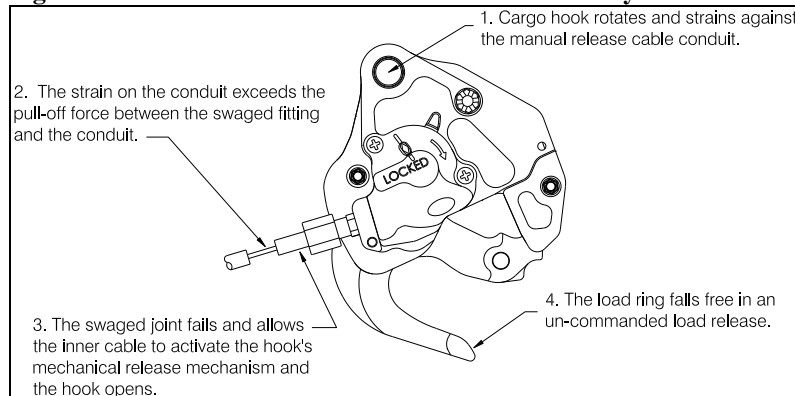

2.7 Placard Installation

Install appropriate load limitation placard, P/N 215-167-00 (1660 lb max. hook load). Locate the placard on the belly of the helicopter, visible to the ground operator and near the hook.

2.8 Installation Check-Out

After installation of the Cargo Hook Sling Suspension System, perform the following functional checks.

1. Swing the installed Cargo Hook Sling Suspension to its full extremes to ensure that the manual release cable assembly and the electrical release cable have enough slack to allow full swing of the cargo hook assembly without straining or damaging the cables. The cables must not be the stops that prevent the Cargo Hook from swinging freely in all directions.
2. With no load on the cargo hook load beam, pull the handle operated cargo hook mechanical release, the Cargo Hook should release. Reset the cargo hook load beam.
3. With no load on the cargo hook load beam, depress the cargo hook electrical release button, the Cargo Hook should release. Reset the cargo hook load beam.
4. Perform an EMI ground test per AC 43.13-1b section 11-107. For equipment that can only be checked in flight an EMI flight test may be required.



The cargo hook is of a class of equipment not known to have a high potential for interference. This class of equipment does not require special EMI installation testing (i.e. FADEC) as required in paragraphs 7 and 8 of FAA policy memorandum ASW-2001-01.

5. Power on the Indicator and allow it to warm up for 5 minutes (with no load on the hook). Press both Indicator buttons at the same time to go to the Setup Mode. Scroll through the menu until the symbol “0 in” is displayed, then press the right button. Remove any weight that is not to be zeroed out and press either button to complete the procedure.

2.9 Component Weights

The weights of the Cargo Hook Sling Suspension System components are listed below.

Table 2-2 Component Weights and Cgs

Item	Weight	Station
Removable Provisions	5.0 lbs (2.27 kg.)	130.2 in (3307 mm)
Fixed Provisions	3.7 lbs (1.68 kg.)	92 in. (2337 mm)
Complete Install	8.7 lbs (3.95 kg.)	113.9 in (2894 mm)

2.10 Paper Work

In the US, fill in FAA form 337 for the initial installation. This procedure may vary in different countries. Make the appropriate aircraft log book entry. Place the Rotorcraft Flight Manual Supplement P/N 121-013-01 in the Rotorcraft Flight Manual.

This page intentionally left blank.

Section 3

Load Weigh System Operation Instructions

Indicator Front Panel

The C-39 Indicator front panel includes the following features.

- The four 7 segment LCD digits show the weight on the Cargo Hook and display various setup information.
- The Legends clarify the digital display, i.e. - when the LB Legend is turned on, the display will be pounds, etc.
- The right button is used to Zero the display in the Run Mode and select the digit to be changed in the Setup Mode.
- The left button is used to Un-Zero the display in the Run Mode and scroll the selected digit in the Setup Mode.

Figure 3-1 Front Panel

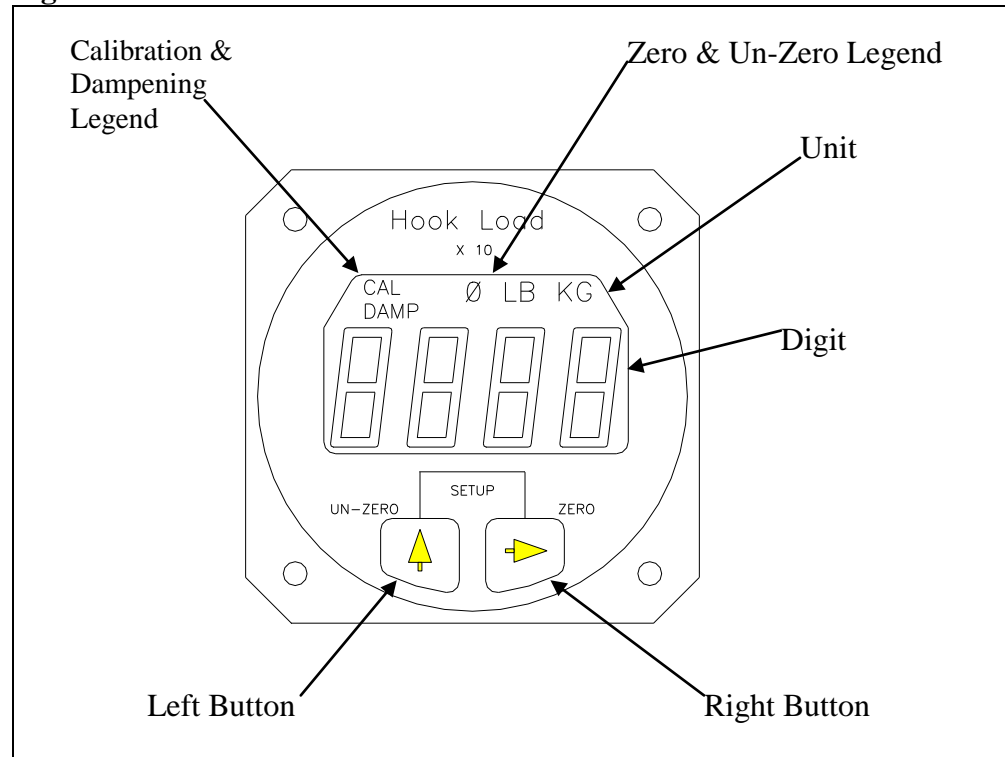

The Run Mode

The C-39 Indicator has two operating modes, Run and Setup. The Run Mode is used to display the cargo hook weight and the Setup Mode is used to setup or configure the Indicator to the helicopter and to the Load Cell. When powered up, the Indicator always comes on in the Run Mode.

After the Indicator has been correctly installed, power it up by activating the aircraft electrical system. The Indicator will go through a self-diagnostic routine. During this routine the display will display all of the digits and legends. If a problem is found during the routine an Error Code will be displayed. For an explanation of Error Codes see the section *Error Codes*. After the diagnostic routine the display should look like this:

Figure 3-2 After Diagnostic Routine

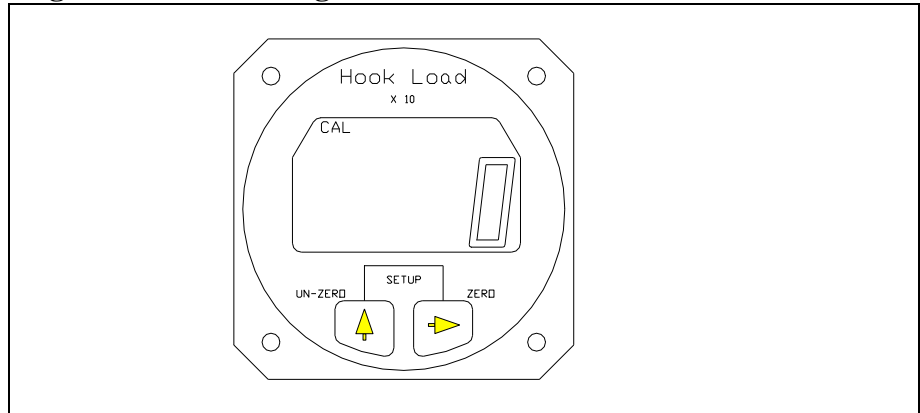

The illustration is of the Indicator in the Run Mode with no load on the hook. Note the LB legend displayed.

Figure 3-3 LB Legend Displayed

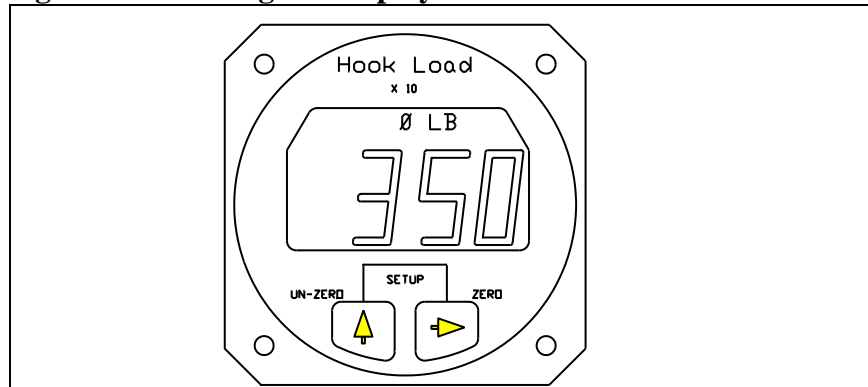

The illustration is a typical hook load reading. The display is 3,500 pounds, note the last digit is not displayed.

The Run Mode continued

To Zero or Tare the Display

The zero feature is used to zero or tare the weight on the Cargo Hook that is not wanted, such as the weight of a cargo net or long line. The Right button is used to zero the Indicator reading. When the Right button is pressed the display is zeroed. The zero legend is turned on and the zeroed number is stored in memory. If the Right button is pressed again, before the Un-zero button is pressed, the display blinks in response to the button closure. Zero is only available in the Run Mode.

Figure 3-4 Zeroing the Display

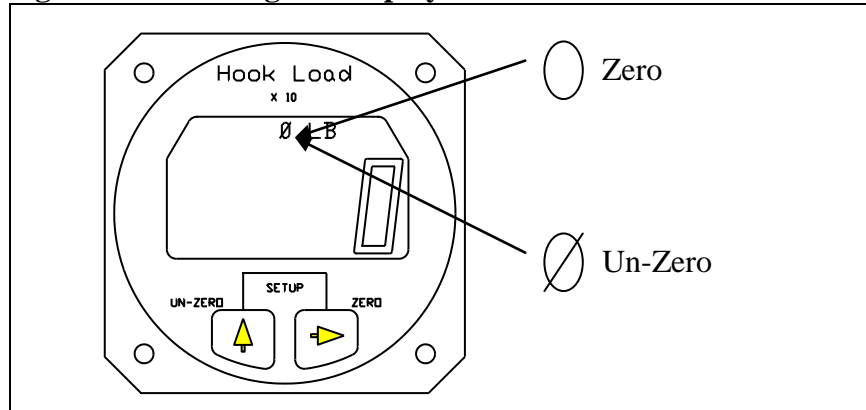

To Un-Zero the Display

The Left button is used to add the zeroed value back into the current Indicator reading or Un-zero the display. When the Left button is pressed, the number previously zeroed is added to the current display and the Un-zero legend is turned on. If the Left button is again pressed before the zero button is pressed, the display blinks in response to the button closure. Un-Zero is only available in the Run Mode.

The Run Mode continued

Error Codes

Error Codes are the result of difficulties discovered during the Indicator diagnostic tests. Diagnostic tests occur at power up and during the execution of certain routines. Listed below is a matrix of the Error Code displays, their meaning and possible corrective action. Pressing either button will usually bypass the error code, however, the displayed information may be suspect.

Table 3-1 Indicator Error Codes

DISPLAY	CAUSE	POSSIBLE CORRECTIVE ACTION
Err 1	A/D or D/A circuit failure	Potential short in the optional analog meter cable. Clear short and power cycle the Indicator by turning the power to the Indicator off for a few moments. If Error Code continues, return the Indicator to the factory.
Err 2	NV Ram failure	Power cycle the Indicator; if Error Code continues, return the Indicator to the factory.
Err 3	NV Ram write failure	Re-enter data, if Error Code continues, return the Indicator to the factory.
Err 4	NV Ram busy failure	Power cycle the Indicator, if Error Code continues return the Indicator to the factory.

The Setup Mode

The C-39 Indicator can be used with a wide range of helicopters and load cells. The Setup Mode on the Indicator matches the Indicator to the Load Cell and to the helicopter. This is accomplished by entering data into the Indicator. Entered data includes the load cell Calibration Code, the units that the Indicator should read-out (pounds or kilograms), and several other items.

The Indicator has a group of Setup routines, arranged in menu form, that are used to configure the Indicator. Shown on the next page is a matrix of the Setup routines and a brief discussion of their function and how they are programmed. A complete discussion of each setup item is presented later in this section.

To enter the Setup Mode press both the Right and Left buttons at the same time while the Indicator is powered up and in the Run Mode. To exit the Setup Mode and return to the Run Mode, press both the buttons at the same time. If you are in a Setup routine and have started to change an entry, but you change your mind before completing the procedure, power cycle the Indicator to exit the Setup Mode and then go to the Run Mode without changing the item. The Indicator is power cycled by turning the Indicator power off for a few moments.

The Setup Mode, continued

Table 3-2 Indicator Setup Routines

MENU	FUNCTION	DISPLAY
Press the Left button to scroll through the menu	Press the Right button to view or change the menu item.	To return to the Run Mode press both the Right and Left buttons at the same time.
DAMP	<u>Dampening Level</u> , sets the pilots preference for display dampening.	Blinking display is previously entered Dampening Level. Select the desired dampening level by pressing the Left button.
CODE	<u>Calibration Code</u> , matches the Indicator to the Load Cell.	Display is previously entered CAL Code. The Code is changed by selecting the digit to be changed with the Right button. The selected digit will blink. Change the blinking digit by pressing the Left button.
0 in	<u>Installation ZERO</u> , matches the Indicator to the installed Load Cell and to the helicopter. After this procedure the display will be zero when no load is on the Cargo Hook.	Display is a combination of load on the Load Cell, and normal load cell zero offset. Remove all weight from the installed Load Cell except the Cargo Hook, and press any button to complete the procedure and return to the Run Mode.
LOAD	<u>Load</u> , is used to calibrate the system by lifting a known load.	No previous display is shown. Enter the known load using the Right button to select the digit to be changed and Left button to enter the number. Known load is entered "X 10" i.e.; 5000 kilograms is entered as 500. After the known load is entered, press both buttons at the same time and lift the known load. When the load is stabilized press either button. A new Calibration Code will be calculated and the known load will be displayed. This completes the procedure.
Scale	<u>Scale</u> , matches the analog output of the Indicator to an optional remote analog meter.	Display is previously entered number. To change the number use the Right button to select a digit, use the Left button to scroll the digit to the desired number. Entry is times 10.
LB KG	<u>Units</u> , selects the Indicator units (pounds or kilograms).	Display is previously selected unit. To change the unit, use the Left button.
XX - V	<u>Version</u> , is the revision level of the Indicator hardware and software.	Version is for information only, it cannot be changed.

The Setup Mode, continued

Indicator Dampening

The Damp or dampening routine allows the pilot to adjust the Indicator dampening level to his preference. The dampening routine is a program that stabilizes the Indicator reading. It offers a trade-off between Indicator responsiveness and stability. Ten dampening levels are available, from 0 through 9. At level 0 the display responds to the slightest change in weight. However, if the load bounced even slightly, the display digits would respond instantly, making the display look unstable. With a dampening level of 9, the display would be stable under the most turbulent conditions, however, it would take several seconds for the display to respond to a change in weight. The ideal dampening level will depend on the flying conditions. A mid range setting of 5 or 6 is usually adequate.

To Look at or Change the Dampening Level

With the Indicator powered up and in the Run Mode, press both buttons at the same time to go to Setup. Scroll through the menu, using the Left button, until the word DAMP is displayed. To look at or change the Dampening Level press the Right button. The display should look like this:

Figure 3-5 Changing Dampening Level

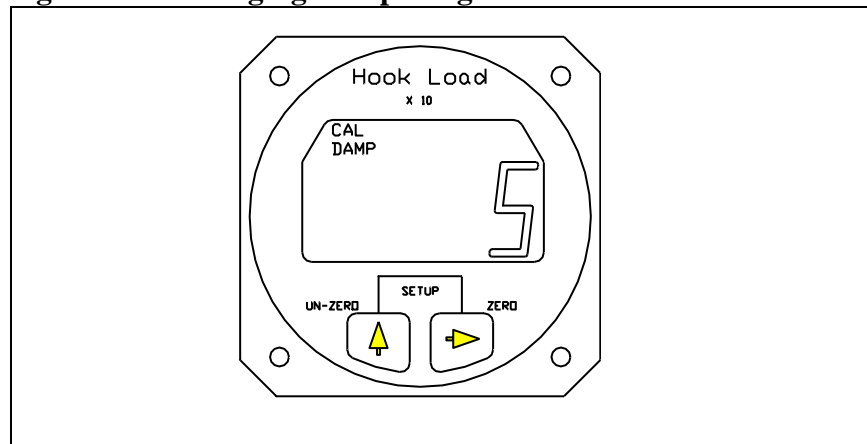

The CAL and the DAMP legend is turned on and the previously set dampening level is displayed. To return to Run without changing the current dampening level press both the Right and Left buttons at the same time. To change the dampening number, use the Left button to scroll the blinking digit to the desired number. After the selection has been made press both the Right and Left buttons at the same time to return to Run.

The Setup Mode, continued

Indicator Calibration

The Calibration Code, or CAL code, is a mandatory input. The Indicator will not accurately display the load without the correct Calibration Code. The Calibration Code scales the signal from the Load Cell. If the C-39 Indicator was supplied as part of a Load Weigh System, the Calibration Code will have been entered into the Indicator by the factory, however, it should be confirmed. If the Indicator is to be mated to a different Load Cell, it must be calibrated before use. Calibration can be done by entering a known Calibration Code or by lifting a known load and having the Indicator calibrate itself. Both options are discussed below.

To Look at or Change the Calibration Code

With the Indicator powered up and in the Run Mode, press both buttons at the same time to go to Setup. Scroll through the menu until the word CODE is displayed, then press the Right button. The display should look like this:

Figure 3-6 Changing the CAL Code

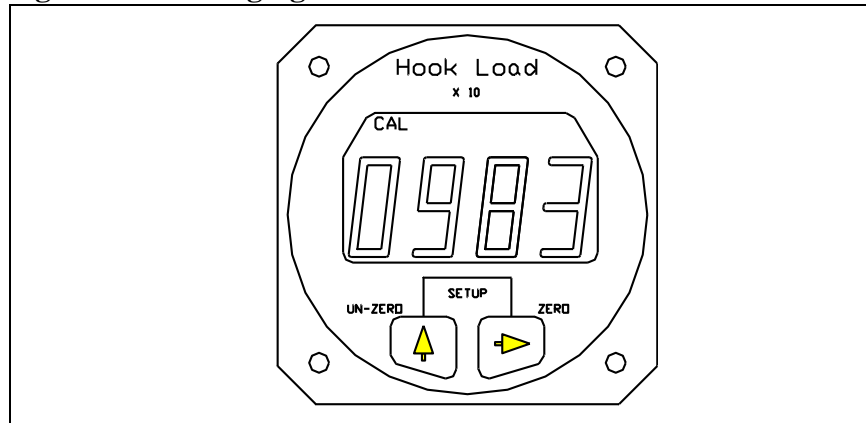

The CAL legend is turned on and the previously entered or computed Calibration Code is displayed. To return to Run without changing the CAL Code, press both the Right and Left buttons at the same time. To change the Calibration Code, use the Right button to select the digit to be changed, then use the Left button to scroll the blinking digit to the desired number. When the Calibration Code has been entered, press both the Right and Left button at the same time to return to Run.

NOTICE

Depending on the type of Load Cell, the Calibration code could be a 3 or 4 digit number. If the Calibration Code is a 3 digit number a leading zero (0) must be used. For example if a Load Cell had a CAL Code of 395 it would be entered as 0395.

The Setup Mode, continued

To Look at or Change the Calibration Code, continued

If the load cell Calibration Code is not known or as a cross check, the Indicator can generate the Calibration Code. This is done by entering the weight of a known load into the Indicator LOAD routine and then lifting the load. See the section Calibration by Lifting a Known Load.

Installation Zero

Installation zero is a routine that matches the Indicator to the ***INSTALLED*** Load Cell. It adjusts the Indicator reading to compensate for the weight of the Cargo Hook on the Load Cell and whatever zero offset is built into the Load Cell. The Installation Zero procedure is not mandatory. If done the Indicator will read zero when the Un-Zero button is pressed and there is no weight on the Cargo Hook. If the Installation Zero is not done, the Indicator will show the weight of the Cargo Hook plus the value of the Load Cell zero offset.

To Run the Installation Zero Routine

With the Indicator powered up and in the Run Mode, press both buttons at the same time to go to Setup. Scroll through the menu until the symbol "0 in" is displayed, then press the Right button. The CAL legend will be turned on and the current weight on the Cargo Hook will be displayed and blinking. Remove any weight that is not to be zeroed out and press either button to complete the procedure and return to the Run Mode.

Calibration by Lifting a Known Weight

Calibration by lifting a known weight is a Setup routine that calculates the Calibration Code for the Load Cell attached to the Indicator. It is useful if the load cell Calibration Code is not known or as a cross check to the accuracy of a known Calibration Code. The procedure is done by entering the known weight into the Indicator and then lifting the weight. This procedure can be done in the shop or on the helicopter. The accuracy of the procedure is directly related to the weight of the known load. If for example the procedure was done with a 1,000 pound load that was assumed to weigh only 900 pounds, all subsequent lifts would be displayed 10% light.



Be sure to include the weight of everything between the Cargo Hook and the load, i.e. the cable, net, dirt, etc.

The closer the known load approaches the lifting capacity of the helicopter, the more accurate the calculated Calibration Code will be.

The Setup Mode, continued

To Run the Calibration by Lifting a Known Weight Routine

With the Indicator powered up and in the Run Mode, press both buttons at the same time to go to Setup. Scroll through the menu until the word **LOAD** is displayed, then press the Right button. The display should look like this:

Figure 3-7 Running CAL Routine

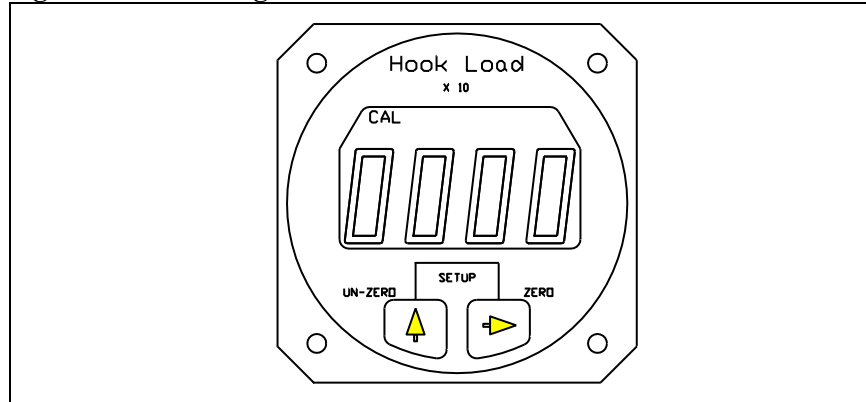

The CAL legend is turned on and the first digit is blinking. The previous load is not displayed. At this point if you wish to return to the Run Mode without changing the Calibration Code, power cycle the Indicator. At this point it is not possible to return to the Run Mode without changing the Calibration Code by using the buttons on the Indicator front panel.

To proceed with the procedure, use the Right button to select the digit to be changed, then use the Left button to scroll the blinking digit to the desired number. Note that the known weight is entered "X 10"; a 1000 pound load is entered as 100. When the known load has been entered, press both the Right and Left button at the same time. The display will look like this:

Figure 3-8 Entering Load in CAL Routine

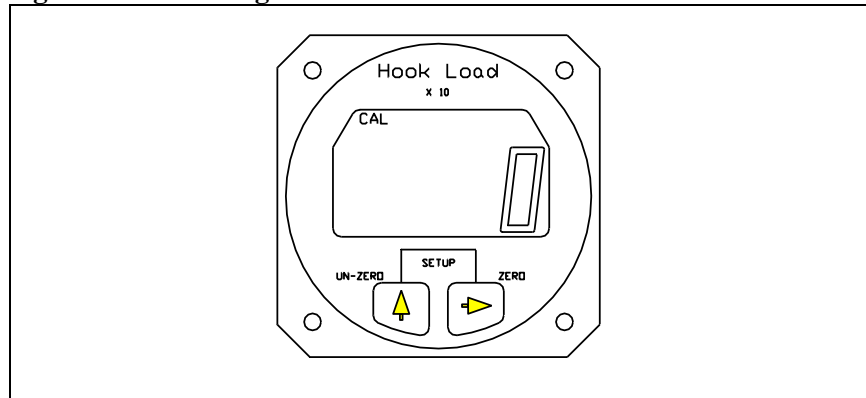

The Setup Mode, continued

Calibration by Lifting a Known Weight, continued

The CAL legend and the digits will be blinking. Again, at this point if you wish to return to the Run Mode without changing the Calibration Code, power cycle the Indicator. It is not possible to return to the Run Mode by using the buttons on the Indicator front panel without changing the Calibration Code. If you wish to proceed, lift the known load and when it is stabilized, press either button to complete the procedure. The Indicator will display the load. This ends the procedure. The Indicator is now calibrated to the Load Cell. It is a good practice to go to the Code routine and record the new Calibration code for later reference.

Setting the Scale for a remote analog meter

The Scale routine is used when a user supplied analog meter is connected to the Indicator. It is used to match or calibrate the analog meter to the Indicator. The Indicator outputs a 0 to 5 VDC analog signal which is proportional to the Load Cell load. The Scale number tells the Indicator at what point in pounds or kilograms it should reach the 5 VDC output. If for example a 5 volt analog meter is used and its full scale reading is 10,000 pounds, the number entered into the Indicator Scale routine would be 1000 (the number is entered X 10). This number tells the Indicator that it should output the proportional 0 to 5 VDC signal between zero pounds and 10,000 pounds.

The Scale number does not affect Onboard Slave Meters, P/N 210-106-00 or 210-180-00. This number only affects user supplied instruments connected to the analog out signal.

To Look at or Change the Scale

With the Indicator powered up and in the Run Mode, press both buttons at the same time to go to Setup. Scroll through the menu until the word SCALE is displayed, then press the Right button. The display should look like this:

Figure 3-9 Changing the Scale

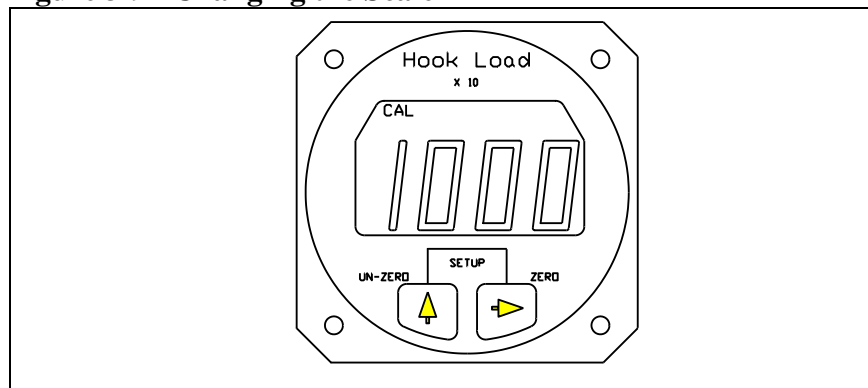

The Setup Mode, continued

To Look at or Change the Scale, continued

The CAL legend is turned on and the previously set Scale number is displayed. To return to Run without changing the Scale, press both the Right and Left button at the same time. To change the Scale number, use the Right button to select a digit to be changed, then use the Left button to scroll the blinking digit to the desired number. When the complete Scale number has been entered, press both the Right and Left button at the same time to return to Run.

Select KG or LB Units

The units routine sets the display to read in pounds (LB) or kilograms (KG).

To look at or change the Units

With the Indicator powered up and in the Run Mode, press both buttons at the same time to go to Setup. Scroll through the menu until the word LB or KG is displayed, then press the Right button. The display should look like this:

Figure 3-10 Changing the Units

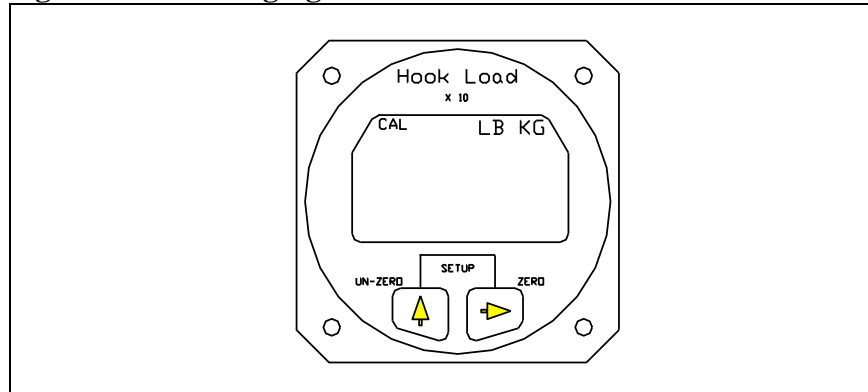

The CAL legend is turned on and the previously set unit is displayed. To return to Run without changing the units, press both the Right and Left button at the same time. To change the units press the Left button. When the selection has been made, press both the Right and Left button at the same time to return to Run.

NOTICE

The selected units are displayed when in the Run Mode.

The Setup Mode, continued

Indicator Version

The Version routine displays the Indicator's hardware and software revision levels. Version is set at the factory and cannot be changed.

Figure 3-11 Looking at Indicator Version

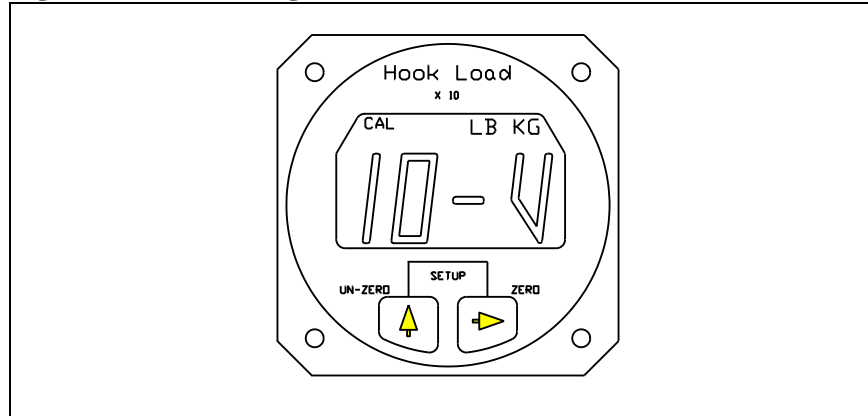

Section 4

Operation Instructions

Operating Procedures

Prior to a flight involving external load operations perform the following.

1. Activate the electrical system and press the Cargo Hook release button to ensure the cargo hook electrical release is operating correctly. The mechanism should operate smoothly and the Cargo Hook must release. Reset the hook by hand after the release. If the hook does not release or re-latch, do not use the unit until the difficulty is resolved.



The cargo hook release solenoid is intended to be energized only intermittently. Depressing the electrical release button continuously in excess of 20 seconds will cause the release solenoid to overheat, possibly causing permanent damage.

2. Activate the manual release lever to test the cargo hook manual release mechanism. The mechanism should operate smoothly and the Cargo Hook must release. Reset the load beam by hand after release. Verify that the hook lock indicator on the side of the hook returns to the fully locked position. If the hook does not release or re-latch, do not use the unit until the problem is resolved.



In the fully locked position the hook lock indicator must align with the lines on the manual release cover (see Figure 4.1).

Figure 4.1 Hook Lock Indicator

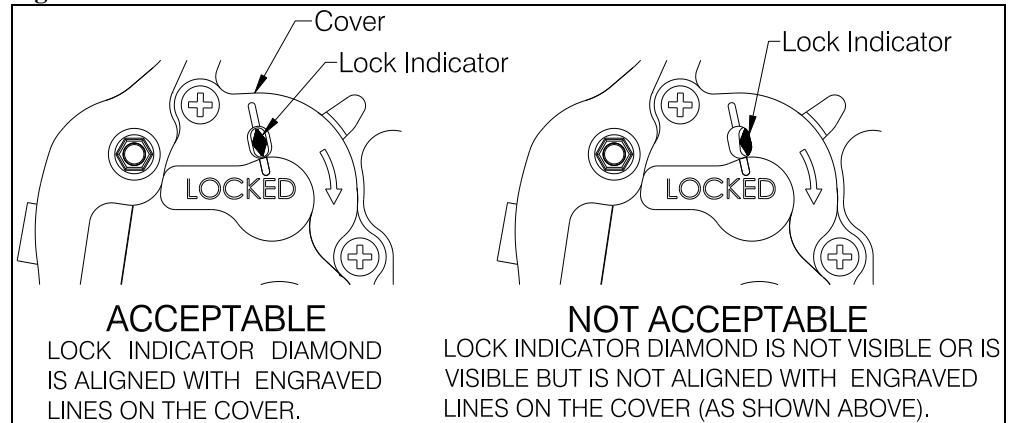

Disconnecting Removable Provisions

For helicopter missions in which the cargo hook sling suspension system is not needed, its removable provisions may be removed per the following instructions.

1. Remove the removable section of the manual release cable by unclipping it from the bracket on the belly of the helicopter, disengaging the locking pin and unthreading the Adapter Fitting. Unclip the Release Cable Cap (see below) from the bracket and thread it over the open end of the bracket and clip it into the inboard spring clip on the bracket.

Figure 4.2 Manual Release Cable Disconnect

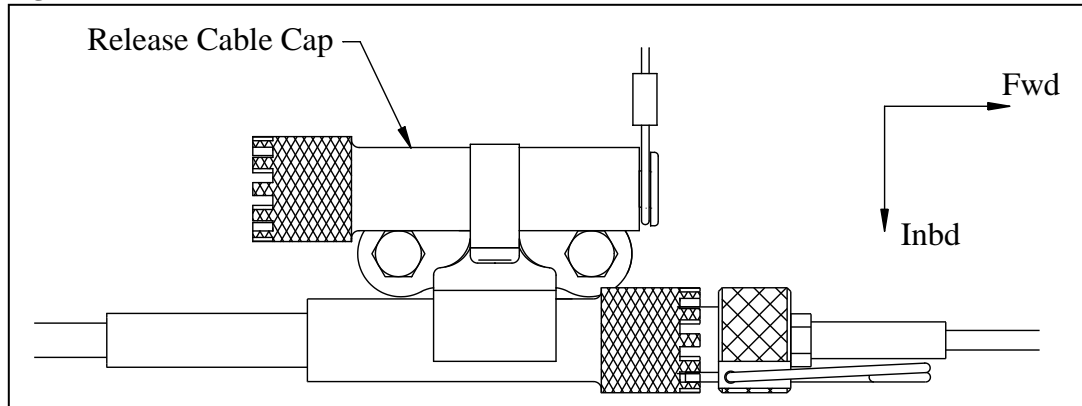

2. Disconnect the electrical release harness and the load cell harness at the bulkhead connectors at the forward fuel tank support frame.
3. Remove the Sling Suspension at the helicopter hard point (reference Figure 2.4.1).

Cargo Hook Loading

The cargo hook can easily be loaded with one hand. A load is attached to the hook by pushing the ring upward against the upper portion of the load beam throat, as illustrated in Figure 4.3, until an internal latch engages the load beam and latches it in the closed position.

Figure 4.3 Cargo Hook Loading

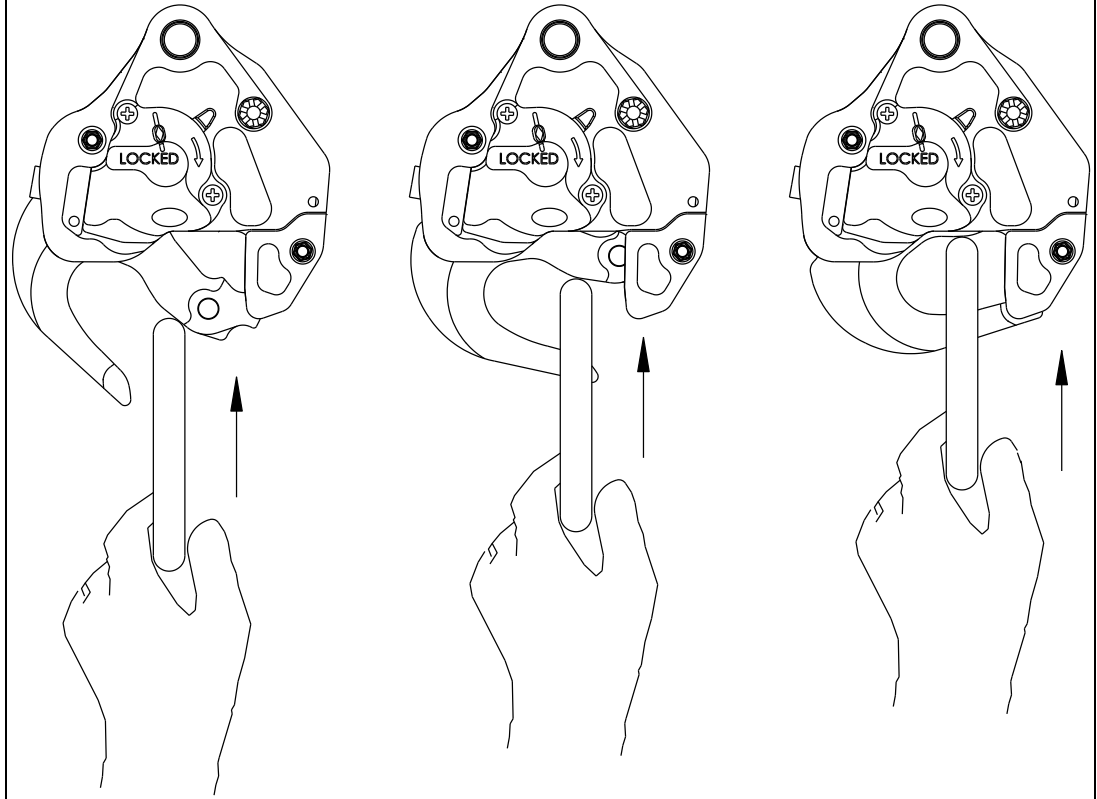

Cargo Hook Rigging

Extreme care must be exercised when rigging a load to the Cargo Hook. Steel load rings are recommended to provide consistent release performance and resistance to fouling. The following illustration shows the recommended rigging, but is not intended to represent all rigging possibilities.



Some combinations of small primary rings and large secondary rings could cause fouling during release.

It is the responsibility of the operator to assure the cargo hook will function properly with each rigging.

Nylon Type Straps and Rope



Nylon type straps (or similar material) or rope must not be used directly on the cargo hook load beam. If nylon straps or rope must be used they should be first attached to a steel primary ring. Verify that the ring will freely slide off the load beam when it is opened. Only the primary ring should be in contact with the cargo hook load beam.

Cargo Hook Rigging continued

Figure 4.4 Example of Recommended Cargo Hook Rigging

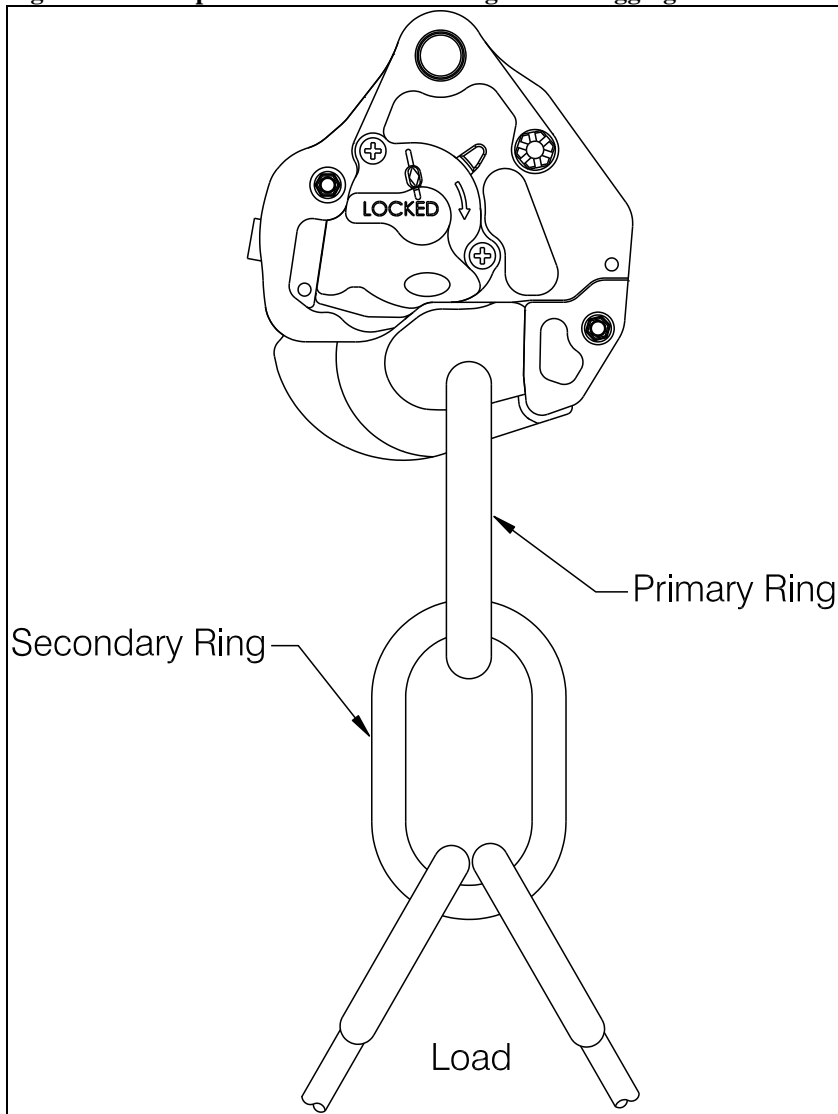

This page intentionally left blank.

Section 5

Maintenance

Refer to the Instructions for Continued Airworthiness (ICA) manual 123-012-01 for maintenance of the cargo hook suspension system. For maintenance of the cargo hook refer to Cargo Hook Component Maintenance Manual 122-017-00.

Instructions for Returning Equipment to the Factory

If an Onboard Systems product must be returned to the factory for any reason (including returns, service, repairs, overhaul, etc.) obtain an RMA number before shipping your return.



An RMA number is required for all equipment returns.

- To obtain an RMA, please use one of the listed methods.
 - Contact Technical Support by phone or e-mail (Techhelp@OnboardSystems.com).
 - Generate an RMA number at our website: <http://www.onboardsystems.com/rma.php>
- After you have obtained the RMA number, please be sure to:
 - Package the component carefully to ensure safe transit.
 - Write the RMA number on the outside of the box or on the mailing label.
 - Include the RMA number and reason for the return on your purchase or work order.
 - Include your name, address, phone and fax number and email (as applicable).
 - Return the components freight, cartage, insurance and customs prepaid to:

Onboard Systems
13915 NW 3rd Court
Vancouver, Washington 98685
USA
Phone: 360-546-3072

This page intentionally left blank.

Section 6

System Part Numbers

210-204-00 AS 350 Sling Fixed Provisions

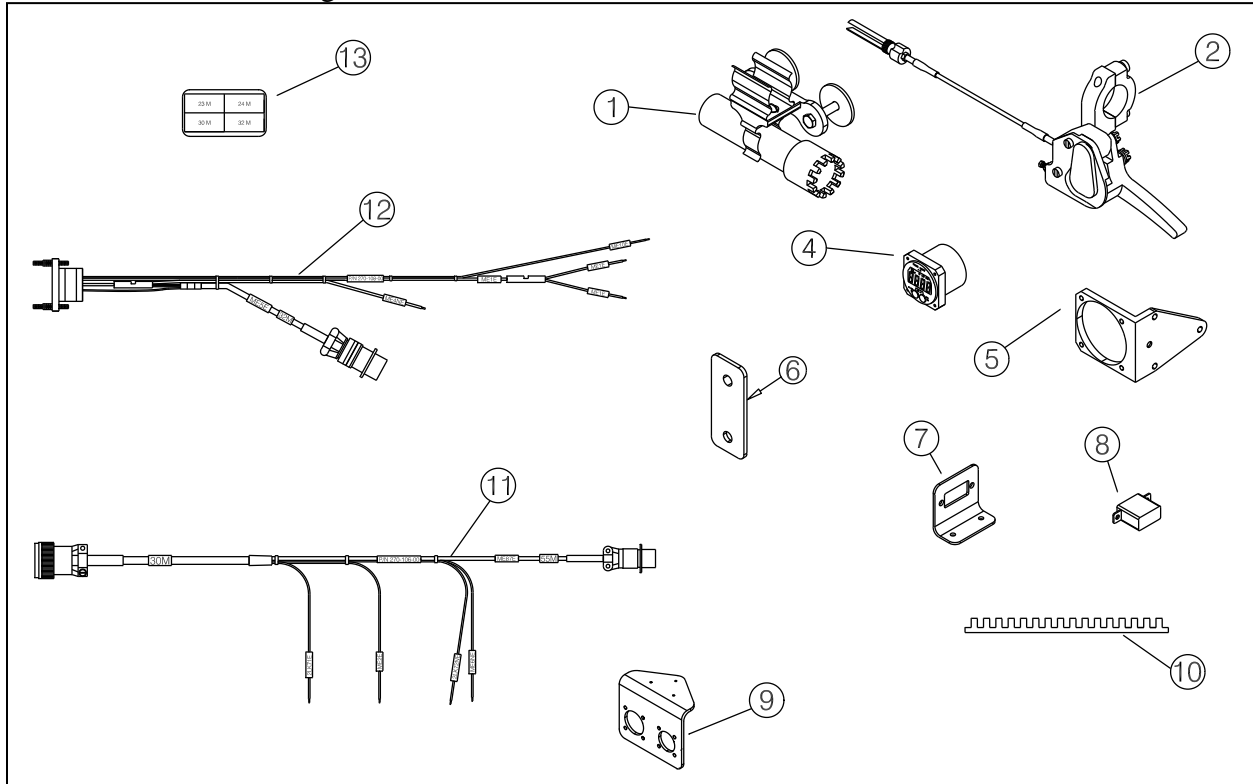

Item	Part Number	Description	Qty
1	232-151-00	Quick Disconnect Support Assembly	1
2	232-150-00	Release Handle Assembly	1
4	210-095-00	C-39 Indicator	1
5	290-772-00	Indicator Mount Bracket	1
6	290-781-00	Cable Support Bracket	1
7	290-783-00	Relay Bracket	1
8	445-005-00	Relay	1
9	290-782-00	Connector Bracket	1
10	500-065-00	Grommet Edging	1
11	270-106-02	Load Weigh Internal Harness	1
12	270-108-00	Release Internal Harness	1
13	215-165-00	Multiple Sticker Sheet	1

System Part Numbers continued

210-206-01 AS350 Sling Removable Provisions

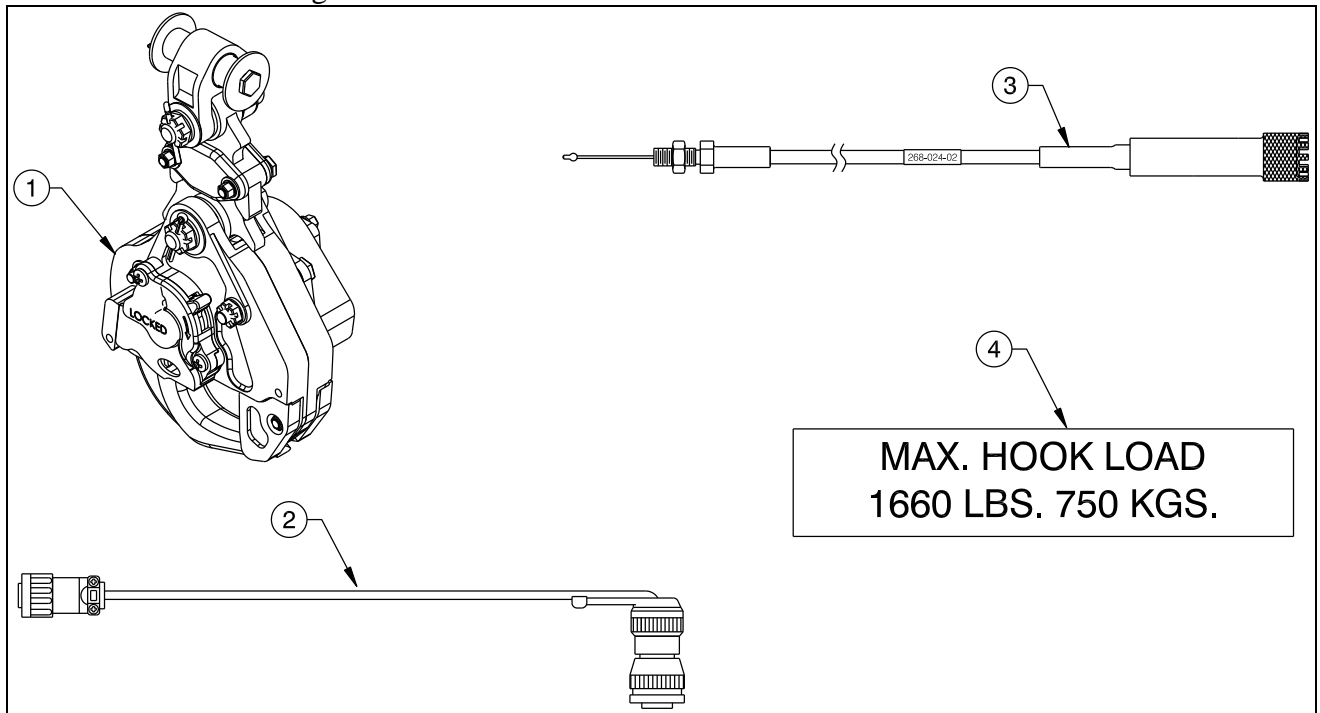

Item	Part Number	Description	Qty
1	232-435-00	Cargo Hook Sling Assembly	1
2	270-110-01	Electrical Release Cable Assembly	1
3	268-024-02	Manual Release Cable Assembly	1
4	215-167-00	Max Hook Load 1660 Decal	1

System Part Numbers continued

232-150-00 Release Handle Assembly

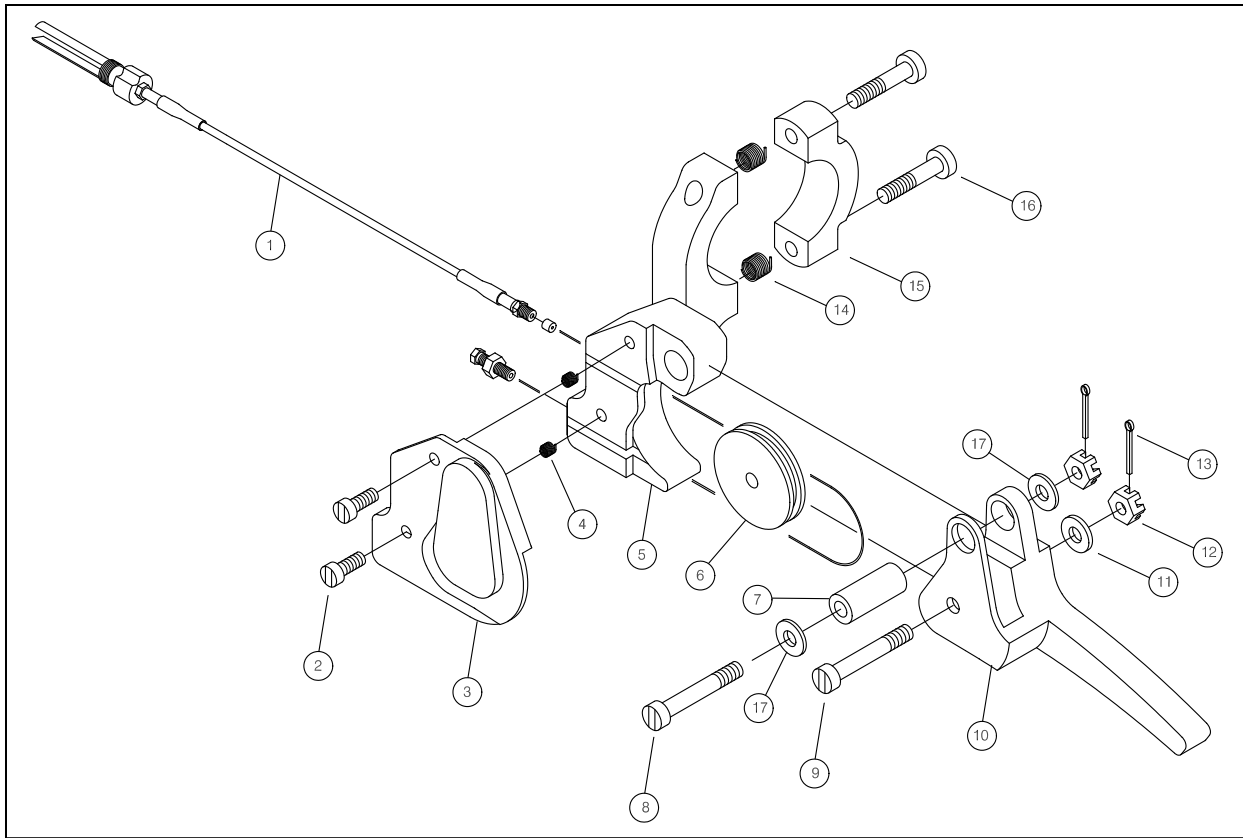

Item	Part Number	Description	Qty
1	268-025-00	Fixed Manual Release Cable	1
2	510-317-00	Screw	2
3	290-757-00	Cover	1
4	510-210-00	8-32 Locking Heli-Coil	2
5	290-754-00	Lever Body	1
6	517-049-00	Pulley	1
7	290-759-00	Shaft	1
8	510-450-00	Bolt, handle pivot	1
9	510-449-00	Bolt, pulley pivot	1
10	290-755-00	Handle	1
11	510-042-00	Washer	1
12	510-082-00	Nut	2
13	510-125-00	Cotter Pin	2
14	510-248-00	10-32 Heli-Coil	2
15	290-753-00	Clamp Half	1
16	510-390-00	Screw, Mounting Clamp	2
17	510-095-00	Washer	3

System Part Numbers continued

232-151-00 Quick Disconnect Support Assembly

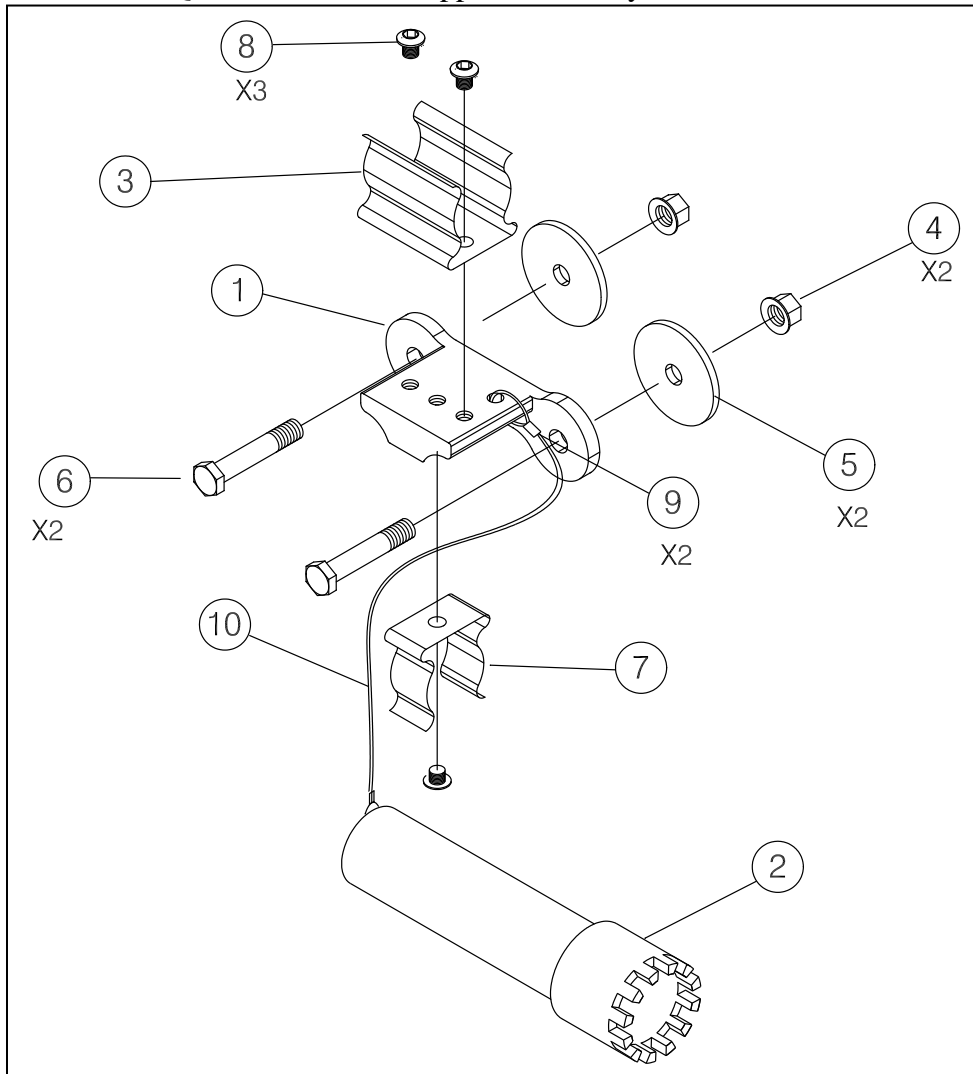

Item	Part Number	Description	Qty
1	290-797-00	Attach Bracket	1
2	290-791-00	Release Cable Cap	1
3	514-053-00	Spring Clip	1
4	510-102-00	Nut	2
5	510-085-00	AN970-3	2
6	510-455-00	NAS6603-13	2
7	514-050-00	Spring Clip	1
8	510-211-00	Button Head Screw	3
9	531-016-00	Crimp Sleeve	2
10	531-015-00	Lanyard	6"

System Part Numbers continued

232-144-00 Sling Gimbal Sub-Assembly

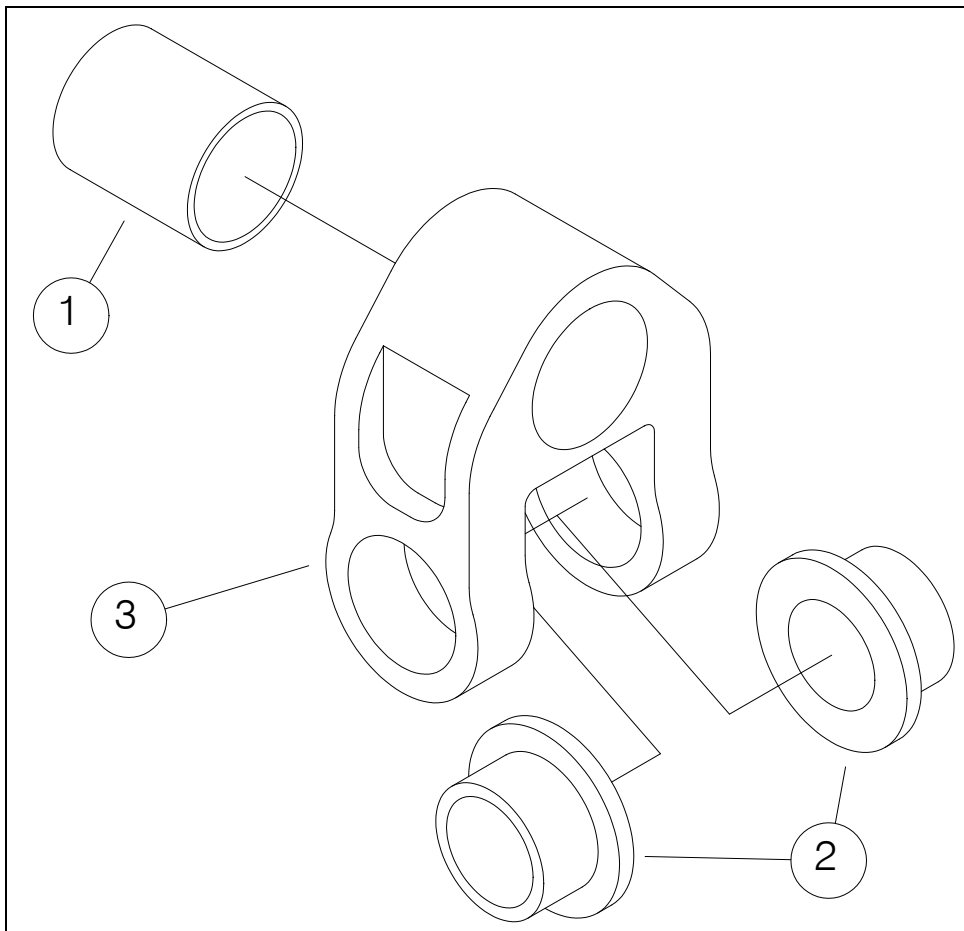

Item	Part Number	Description	Qty
1	517-051-00	Bushing	1
2	290-294-00	Attach Bushing	2
3	290-767-00	Gimbal	1

System Part Numbers continued
232-435-00 Cargo Hook Sling Assembly

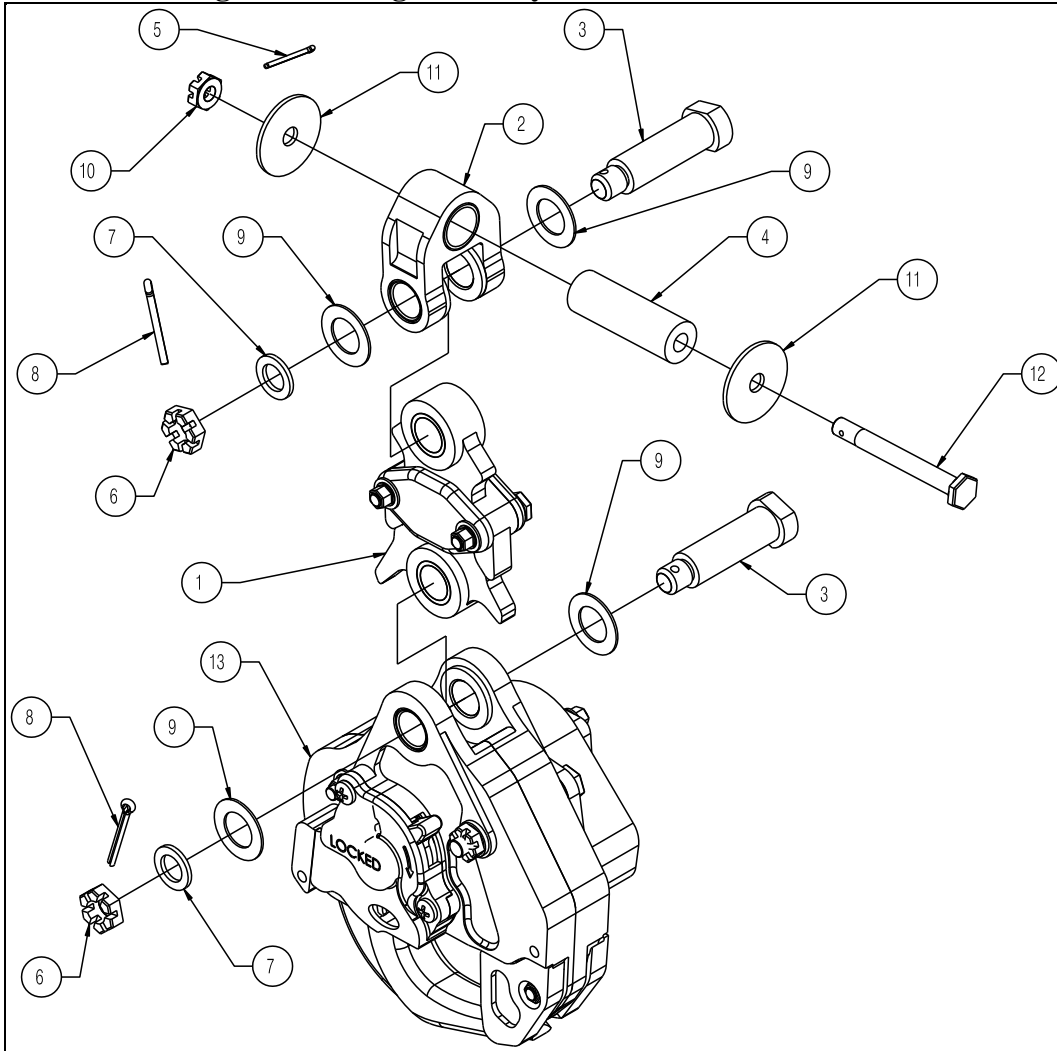

Item	Part Number	Description	Qty
1	210-203-03*	Load Cell Assembly	1
2	232-144-00	Sling Gimbal Assembly	1
3	290-332-00	Attach Bolt	2
4	290-766-00	Gimbal Pin	1
5	510-081-00	Cotter Pin	1
6	510-170-00	Nut	2
7	510-174-00	Washer	2
8	510-178-00	Cotter Pin	2
9	510-183-00	Washer	4
10	510-259-00	Nut	1
11	510-336-00	Washer	2
12	510-451-00	Bolt	1
13	528-029-00	Cargo Hook	1

*Supersedes P/N 210-203-00, these P/N's are interchangeable.

Section 7

Certification

FAA STC

United States of America

Department of Transportation Federal Aviation Administration

Supplemental Type Certificate

Number SR01165SE

This certificate, issued to:

**Onboard Systems International
13915 NW 3rd Court
Vancouver, WA 98685**

certifies that the change in the type design for the following product with the limitations and conditions therefore as specified hereon meets the airworthiness requirements of Part 27 of the Federal Aviation Regulations.

Original Product—Type Certificate Number: H9EU

Make: Eurocopter France

Model: AS350B, AS350B1, AS350B2, AS350B3, AS350BA, AS350D

Description of the Type Design Change: Fabrication of Onboard Systems Model 200-282-00 and 200-282-03, Cargo Hook Sling Suspension Kits in accordance with FAA-approved Onboard Systems Master Drawing List No. 155-087-00, Revision 13, dated October 30, 2009, or later FAA-approved revision.

Installation of the systems in accordance with FAA-approved Onboard Systems Owner's Manual No. listed in the table below, or later FAA-approved revision. This modification must be inspected and maintained in accordance with Section 5 of the FAA-approved Onboard Systems Instructions for Continued Airworthiness (ICA), and Onboard Systems Cargo Hook Service Manual listed in the table below, or later FAA-approved revision.

(See Continuation Sheet on Page 3)

Limitations and Conditions: Approval of this change in type design applies only to the Eurocopter AS350 model rotorcraft listed above. This approval should not be extended to other rotorcraft of these models on which other previously approved modifications are incorporated unless it is determined by the installer that the relationship between this change and any of those other previously approved modifications, including changes in type design, will introduce no adverse effect upon the airworthiness of that rotorcraft. Rotorcraft modified in accordance with this STC must be operated in accordance with a copy of an FAA-approved Onboard Systems Rotorcraft Flight Manual Supplement (RFMS) listed in the table below. (See Continuation Sheet on Page 3)

This certificate and the supporting data which is the basis for approval shall remain in effect until surrendered, suspended, revoked, or a termination date is otherwise established by the Administrator of the Federal Aviation Administration.

Date of application: September 13, 2002

Date reissued:

Date of issuance: January 22, 2003

Date amended: May 06, 2010



By direction of the Administrator

A handwritten signature in black ink, appearing to be "D. J. [unclear]".

(Signature)

Acting Manager, Seattle Aircraft Certification Office

(Title)

Any alteration of this certificate is punishable by a fine of not exceeding \$1,000, or imprisonment not exceeding 3 years, or both.

This certificate may be transferred in accordance with FAR 21.47.

United States of America
 Department of Transportation—Federal Aviation Administration
Supplemental Type Certificate
 (Continuation Sheet)

Number SR01165SE

Onboard Systems International

Issued: January 22, 2003

Amended: May 06, 2010

Description of the Type Design Change continued:

KIT P/N	OWNER'S MANUAL NUMBER	INSTRUCTIONS for CONTINUED AIRWORTHINESS and CARGO HOOK SERVICE MANUAL
200-282-00	120-105-00, Revision 12, dated June 20, 2008	123-012-00 Revision 8, dated October 29, 2007 122-005-00 Revision 15, dated April 23, 2009
200-282-03	120-105-01, Revision 0, dated October 08, 2009	123-012-01 Revision 0, dated March 15, 2010 122-017-00 Revision 5, dated July 27, 2009

Limitations and Conditions continued:

SYSTEM PART NUMBER	ROTORCRAFT FLIGHT MANUAL SUPPLEMENT
200-282-00	121-013-00 Revision 0, dated January 14, 2003
200-282-03	121-013-01 Revision 0, dated March 04, 2010

A copy of this certificate, FAA-approved RFMS, ICA, and Service Manual, must be maintained as part of the permanent records of the modified rotorcraft.

If the holder agrees to permit another person to use this certificate to alter the product, the holder shall give the other person written evidence of that permission.

- END -

Any alteration of this certificate is punishable by a fine of not exceeding \$1,000, or imprisonment not exceeding 3 years, or both.

This certificate may be transferred in accordance with FAR 21.47.

Canadian Approval



Transport
Canada

Aviation

Transports
Canada

Aviation

Aircraft Certification Branch
620 - 800 Burrard Street
Vancouver, BC V6Z 2J8

Your file Votre référence
190S-03-169
Our file Notre référence

March 24, 2003

Onboard Systems
13915 NW 3rd Court
Vancouver, WA 98685
USA

Attention: Mr. Ron Pirtle

Subject: Acceptance of Foreign STCs SR01164SE, SR01165SE, and SR01166SE

Dear Sir:

This is in response to your letters dated February 25, 2003 making application for Canadian approvals of the subject STCs.

In accordance with our current policy associated with the review of foreign STCs, some STCs applicable to certain categories of rotorcraft may be accepted solely on the basis of their foreign certification, and do not require the issue of a corresponding certificate by Transport Canada. The subject STCs fall within these criteria.

These STCs will be entered in the national index of STCs that have been reviewed and accepted by Transport Canada for installation on Canadian-registered aeronautical products.

This letter confirms formal acceptance of the referenced STCs by Transport Canada. Should you require additional information with regards to this matter or clarification please do not hesitate to contact the undersigned at (604) 666-5597.

Yours truly,

H. W. Wong
Senior Engineer, Aircraft Certification

for
Minister of Transport

c.c. Mr. Jeffrey E. Duven
Acting Manager, Seattle ACO

Canada

1/1



European Aviation Safety Agency

SUPPLEMENTAL TYPE CERTIFICATE

10030504, REV. 1

This Supplemental Type Certificate is issued by EASA, acting in accordance with Regulation (EC) No. 216/2008 on behalf of the European Community, its Member States and of the European third countries that participate in the activities of EASA under Article 66 of that Regulation and in accordance with Commission Regulation (EC) No. 1702/2003 to

**ONBOARD SYSTEMS INT.
13915 NW 3rd COURT
VANCOUVER WA 98685
USA**

and certifies that the change in the type design for the product listed below with the limitations and conditions specified meets the applicable Type Certification Basis and environmental protection requirements when operated within the conditions and limitations specified below:

Original Product TC Number: EASA.R.008
TC Holder: EUROCOPTER
Model: AS 350 B, AS 350 B1, AS 350 B2
Model: AS 350 B3, AS 350 BA, AS 350 D
Original STC Number: FAA STC SR01165SE

EASA Certification Basis:

As specified in TCDS R.008

The Certification Basis for the original product remains applicable to this certificate/ approval
The certificated noise and/ or emissions levels of the original product are unchanged and remain applicable to this certificate/ approval

Description of Design Change:

Revision of STC EASA.IM.R.S.00542 introducing additional cargo hook kit 200-282-03.

Associated Technical Documentation:

Definition and Installation:

- Onboard Systems Master Drawing List No. 155-087-00, Rev. 13, dated October 30, 2009.
For kit P/N 200-282-00
- Onboard Systems Owner's Manual No. 120-105-00, Rev. 12, dated June 20, 2008.
For kit P/N 200-282-03
- Onboard Systems Owner's Manual No. 120-105-01, Rev. 0, dated October 08, 2009.

See Continuation Sheet(s)

For the European Aviation Safety Agency,

Date of issue: 21.06.2010

Massimo MAZZOLETTI
Certification Manager
Rotorcraft, Balloons, Airships

Note:

The following numbers are listed on the certificate:
EASA old Project Number: EASA.IM.R.S.00542, REV. 1

SUPPLEMENTAL TYPE CERTIFICATE - 10030504, REV. 1 - ONBOARD SYSTEMS INT.

EASA Form 91, Issue 3 - 11/11/2009



Inspection and Maintenance:

For kit P/N 200-282-00

- Onboard Systems Instructions for Continued Airworthiness No. 123-012-00, Rev. 8, dated October 29, 2007.

- Onboard Systems Service Manual No. 122-005-00, Rev. 15, dated April 23, 2009.

For kit P/N 200-282-03

- Onboard Systems Instructions for Continued Airworthiness No. 123-012-01, Rev. 0, dated March 15, 2010.

- Onboard Systems Service Manual No. 122-017-00, Rev. 5, dated July 27, 2009.

Operations:

For kit P/N 200-282-00

- Onboard Systems RFMS No. 121-013-00, Rev. 0, dated January 14, 2003.

For kit P/N 200-282-03

- Onboard Systems RFMS No. 121-013-01, Rev. 0, dated March 04, 2010.

or later revisions of the above listed documents approved by EASA in accordance with EASA ED Decision 2004/04/CF (or subsequent revisions of this decision)

Limitations:

EASA-approved AS 350 Flight Manual and <External Load Transport: Cargo Sling> FM supplement are required.

This STC is approved only for the product configuration as defined in the approved design data referred to in the paragraph "Description". Compatibility with other aircraft/engine configurations shall be determined by the installer.

Installation and operation of the system on AS 350 B3 with the modification OP-3369 incorporated is not approved.

Conditions:

Prior to installation of this modification it must be determined that the interrelationship between this modification and any other previously installed modification and/ or repair will introduce no adverse effect upon the airworthiness of the product.

This Certificate shall remain valid unless otherwise surrendered or revoked.

- end -

Note:

The following numbers are listed on the certificate:

EASA old Project Number: EASA.IM.R.S.00542, REV. 1

SUPPLEMENTAL TYPE CERTIFICATE - 10030504, REV. 1 - ONBOARD SYSTEMS INT.

EASA Form 91, Issue 3 - 11/11/2009