

**PLEASE CHECK WEB SITE AT WWW.ONBOARDSYSTEMS.COM FOR
THE LATEST REVISION OF THIS MANUAL**

Owner's Manual
for the
Cargo Hook
Swing Suspension
System Retrofit Kit
on
Airbus Helicopters AS350
Series Helicopters

System Part Number
200-286-01

Owner's Manual Number 120-107-01
Revision 10
05/12/14



13915 NW 3rd Court Vancouver, Washington 98685 USA
Phone: 360-546-3072 Fax: 360-546-3073 Toll Free: 800-275-0883
www.OnboardSystems.com

This page intentionally left blank.

Record of Revisions

<i>Revision</i>	<i>Date</i>	<i>Page(s)</i>	<i>Reason for Revision</i>
3	07/11/08	2-7, 2-13	Updated electrical schematic (Figure 2.2.7) to show correct termination point for wire ME10E. Corrected rigging dimension from “approximately .125 inches” to “.125 inches minimum”
4	05/06/09	2-15	Revised note in Installation Check-out section regarding EMI test.
5	3/10/10	Section 2 & 6-1	Updated manual to reflect new load weigh harness configuration. Clarified manual release cable rigging instructions including Figure 2.4.4. Updated note regarding EMI test at installation check-out.
6	09/01/10	1-1, 1-4, Section 2, 3-8, 3-9, 3-12, 4-1, 4-3 & 6-1.	Replaced warnings, cautions and notes section with safety labels sections. Updated safety label format to current format throughout document. Added fuel drain guard to kit and associated instructions. Updated weight for fixed provisions to included fuel drain guard kit.
7	01/21/11	5-1 & 6-10	Replaced bolt (P/N 510-505-00) with bolt (P/N 510-762-00) in swing frame assembly parts list. Updated RMA instructions.
8	3/21/11	6-8 & 6-10	Added Fuel Drain Warning Placard to System Parts Numbers section under swing hook/frame assembly.
9	05/02/11	1-4	Added Half Clamp Pad (EC P/N 350A-41-1099-20) to the table of Eurocopter required part numbers.
10	05/12/14	Title, 1-1, 1-3, 1-4, Section 2, 4-3, 4-4, 6-1, & 6-10	Updated Eurocopter to Airbus Helicopters. Replaced load cell P/N 210-249-00 with P/N 210-249-03. Updated cargo hook load rigging instructions. Replaced fuel drain guard P/N 290-889-00 with P/N 290-889-01.

Register Your Products for Automatic Notifications

Onboard Systems offers a free notification service via fax or email for product alerts and documentation updates. By registering your Onboard Systems products at our website, we will be able to contact you if a service bulletin is issued, or if the documentation is updated.

You can choose to receive notices on an immediate, weekly, or monthly schedule via fax, email or both methods. There is no charge for this service. Please visit our website at www.onboardsystems.com/notify.php to get started.

This page intentionally left blank.

CONTENTS

Section 1 **General Information**

- Introduction, 1-1
- Safety Labels, 1-1
- Specifications, 1-2
- Inspection, 1-3
- Bill of Materials, 1-3
- Theory of Operation, 1-5

Section 2 **Installation Instructions**

- Cockpit Indicator Installation, 2-1
- Electrical Wiring Installation, 2-3
- Fuel Drain Guard Installation, 2-9
- Swing Suspension Installation, 2-15
- Removable Manual Release Cable Assembly Installation, 2-17
- External Electrical Cable Installation, 2-20
- Installation Check-Out, 2-21
- Component Weights, 2-22
- Paper Work, 2-22

Section 3 **Load Weigh Systems Operation Instructions**

- Indicator Front Panel, 3-1
- The Run Mode, 3-2
 - To Zero or Tare the Display, 3-3
 - To Un-Zero the Display, 3-3
- Error Codes, 3-4
- The Setup Mode, 3-5
 - Indicator Dampening, 3-7
 - To look at, or change the dampening level, 3-7
 - Indicator Calibration, 3-8
 - To look at or change the calibration code, 3-8
 - Installation Zero, 3-9
 - To run the installation zero routine, 3-9
 - Calibration by Lifting a Known Weight, 3-9
 - To run calibration by known weight routine, 3-10
 - Setting the Scale on a Remote Analog Meter, 3-11
 - To look at or change the scale, 3-11
 - Select KG or LB Units, 3-12
 - To look at or change the units, 3-12
- Indicator Version, 3-13

CONTENTS, *continued*

Section 4 **Operation Instructions**

Operating Procedures, 4-1
Disconnecting Removable Provisions, 4-2
Cargo Hook Loading, 4-3
Cargo Hook Rigging, 4-3

Section 5 **Maintenance**

Instructions for Returning a System to the Factory, 5-1

Section 6 **System Part Numbers**

200-286-01 AS 350 Swing Retrofit Kit, 6-1
210-201-01 AS 350 Swing Removable Provisions, 6-2
232-137-01 Shackle Assembly, 6-3
232-140-01 Forward Attach Cable Assembly, 6-4
232-141-01 Aft Attach Cable Assembly, 6-5
232-142-00 Lower Attach Cable Gimbal Assembly, 6-6
232-143-01 Load Cell Gimbal Assembly, 6-7
232-145-01 Swing Hook-Frame Assembly, 6-8

Section 7 **Certification**

FAA STC, 7-1
Canadian Approval, 7-2
EASA STC, 7-3

Section 1

General Information

Introduction

The P/N 200-286-01 Swing Retrofit Kit is a conversion kit for AS350 operators with an existing Airbus Helicopters cargo hook fixed provisions kit. This kit utilizes some of the existing systems fixed provisions kit components that are compatible with it. These components include the fixed manual release cable, miscellaneous supporting brackets and miscellaneous hardware.

Newer Swing Retrofit Kits (kits shipped after August 2010) include a fuel drain guard which is compatible with fuel tanks on AS350 B2 and B3 helicopters and on AS350B, B1, BA, and D models that have been retrofitted with the B-2 style dual fuel pump type tank. The Airbus Helicopters part number for this tank is 350A55-1015-0251. The fuel drain guard is intended for helicopters with their fuel drain levers previously modified per AD 2005-03-08. See Theory of Operation section for description of fuel drain guard.

Safety Labels

The following definitions apply to safety labels used in this manual.



Indicates a hazardous situation which, if not avoided, will result in death or serious injury.



Indicates a hazardous situation which, if not avoided, could result in death or serious injury.



Indicates a hazardous situation which, if not avoided, could result in minor or moderate injury.



Draws the reader's attention to important or unusual information not directly related to safety.



Used to address practices not related to personal injury.

Specifications

System weights are identified by fixed and removable provisions. Fixed provisions are permanently installed on the aircraft while the removable provisions are easily removed when not required on the helicopter's mission.

Table 1.1 Suspension System Specifications

Design Load	3,086 lbs. (1400 kg.)
Design Ultimate Strength	11,574 lbs. (5250 kg.)
System Weight – Fixed Provisions	4.9 lbs (2.2 kgs)
System Weight – Removable Provisions	30.0 lbs. (13.6 kgs)

Table 1.2 P/N 528-023-01 Cargo Hook Specifications

Design load	3,500 lbs. (1,580 kg.)
Design ultimate strength	13,125 lbs. (5,953 kg.)
Electrical release capacity	8,750 lbs. (3,969 kg.)
Mechanical release capacity	8,750 lbs. (3,969 kg.)
Force required for mechanical release at 3,500 lb.	8 lb. Max. (.600" travel)
Electrical requirements	22-32 VDC 6.9 – 10 amps
Minimum release load	0 pounds
Unit weight	3.0 pounds (1.35 kg.)
Mating electrical connector	PC06A8-2S SR



Load capacities given are for the equipment described only. Loading limits for your particular helicopter model still apply. Consult your flight manual.

Inspection

Inspect the kit items for evidence of damage, corrosion and security of lock wire and fasteners. If damage is evident, do not use the items until they are repaired.

Bill of Materials

The following items are included with the 200-286-01 Swing Retrofit Kit. If shortages are found contact the company from whom the system was purchased.

Table 1.3 Onboard Systems Bill of Materials

Part No.	Description	Qty
120-107-01	Owner's Manual	1
121-015-01	RFMS	1
122-005-00	Cargo Hook Service Manual	1
123-014-01	ICA Maintenance Manual	1
210-095-00	C-39 Indicator	1
215-166-00	Max Hook Load 3086 Decal	1
215-168-00	Max Hook Load 2557 Decal	1
232-137-01	Shackle Assembly	4
232-140-01	Forward Attach Cable Assembly	2
232-141-01	Aft Attach Cable Assembly	2
232-145-01	Hook-Frame Assembly	1
268-024-02	Manual Release Cable Assembly	1
270-106-02	LW Internal Harness	1
270-108-00	Release Internal Harness	1
270-125-00	Ground Strap	1
290-772-00	Indicator Mount Bracket	1
290-782-00	Connector Bracket	1
290-783-00	Relay Bracket	1
290-888-00*	Retainer	1
290-889-01*^	Guard	1
290-893-00*	Bracket	1
445-005-00	Relay	1
510-029-00	Nut	8
510-062-00	Washer	8
510-095-00	Washer	3
510-277-00	Screw	2
510-278-00	Washer	2
510-279-00	Nut	2
510-457-00	Screw	4
510-475-00	Screw	3
510-481-00	Screw	8
510-526-00*	Cotter Pin	2
610-024-00*	Seal	1

* Fuel drain guard component, included with kits shipped after August, 2010.

^ Fuel drain guard P/N 290-889-01 supersedes fuel drain guard P/N 290-889-00.

Bill of Materials continued

To complete the cargo hook installation the following Airbus Helicopters parts may be necessary to obtain (these parts are frequently found to be on the aircraft or are standard Airbus Helicopters parts).

Table 1.4 Airbus Helicopters Part Numbers

Airbus Helicopters P/N	Description	Quantity	Reference
350A-41-1097-20**	Landing Gear Half Clamp – Rear	2	Figure 2.4.1.1
350A-41-1099-20	Half Clamp Pad	2	Figure 2.4.1.1
22201BE120074L	Screw	4	Figure 2.4.1.1
23111AG120LE	Washer	8	Figure 2.4.1.1
ASN52320BH120N	Nut	4	Figure 2.4.1.1
ASNA0078A403	Rivet	3	Figure 2.2.4

** These parts may or may not be installed with a standard aircraft, therefore verification is recommended before purchasing them.

The following is needed for installation of the fuel drain guard and is not included with the kit and should be obtained before installation is begun.

Table 1.5 Needed Supplies

Part Number	Description	Quantity
PR1422-B	Sealant	AR

Theory of Operation

The 200-286-01 Cargo Hook Swing Suspension System Retrofit Kit is comprised of:

- A suspended pyramid frame that supports the cargo hook.
- An electrical release system that provides means for release by pilot actuation of the push-button switch in the cockpit. When the push-button switch is pressed, it energizes the DC solenoid in the cargo hook, and the solenoid opens the latch in the internal mechanism.
- A manual release adapter cable, which interfaces with the existing fixed manual release cable. The manual release system provides a means of releasing a cargo hook load in the event of an electrical release system failure. It is actuated by the existing lever mounted to the collective stick. Ground personnel may also release a load by the actuation of a lever located on the side of the cargo hook.
- A load weigh system, which is comprised of an Indicator mounted to the RH door pillar within the cockpit connected to a load cell between the cargo hook and frame.

A load is attached to the cargo hook by passing a cargo sling ring into the throat of the load beam and pushing the ring against the upper portion of the load beam throat, which will initiate the hook to close. In the closed position, a latch engages the load beam and latches it in this position.

To release the load, the latch is disengaged from the load beam. With the latch disengaged, the weight of the load causes the load beam to swing to its open position, and the cargo sling ring slides off the load beam. The load beam then remains in the open position awaiting the next load.

The Cargo Hook Swing Retrofit kit includes a fuel drain guard. The fuel drain guard protects the fuel drain valve on the helicopter from accidentally being opened or damaged by the cargo swing. The fuel drain valve is located on the bottom of the fuel tank and extends below the belly skin of the helicopter. In this position it is vulnerable to damage or uncommanded opening. The most common occurrence of the cargo hook swing suspension striking the fuel drain valve happens when the helicopter lands on snow or on uneven terrain. The swing has limited ground clearance and when the skid gear sinks into the snow, the swing suspension is pushed upward into the fuel drain valve, opening it and causing fuel to drain. The fuel drain valve can also be opened in flight by the swing suspension flying vertically due to aerodynamics when ferrying with no load or from recoil effects from releasing large cargo hook loads.

This page intentionally left blank.

Section 2

Installation Instructions

These procedures are provided for the benefit of experienced aircraft maintenance facilities capable of carrying out the procedures. They must not be attempted by those lacking the necessary expertise.

The installation instructions for the AS350 swing suspension are subdivided into separate sub-installations:

1. Cockpit Indicator Installation – Section 2.1
2. Fixed Electrical Wiring Installation – Section 2.2
3. Fuel Drain Guard Installation – Section 2.3
4. Swing Suspension Installation – Section 2.4
5. Removable Manual Release Cable Installation – Section 2.5
6. Removable Electrical Cables Installation – Section 2.6

2.1 Cockpit Indicator Installation

The C-39 Indicator is mounted on the RH door pillar.

Disconnect the wiring harness and remove the existing Airbus Helicopters load weigh indicator.

Install the Indicator Mount Bracket using the same mounting holes as the Airbus Helicopters indicator with three screws (P/N 510-475-00) and three washers (P/N 510-095-00). Re-use the electrical bonding screw at the fourth location (see below).

Figure 2.1.1 Indicator Bracket Hardware

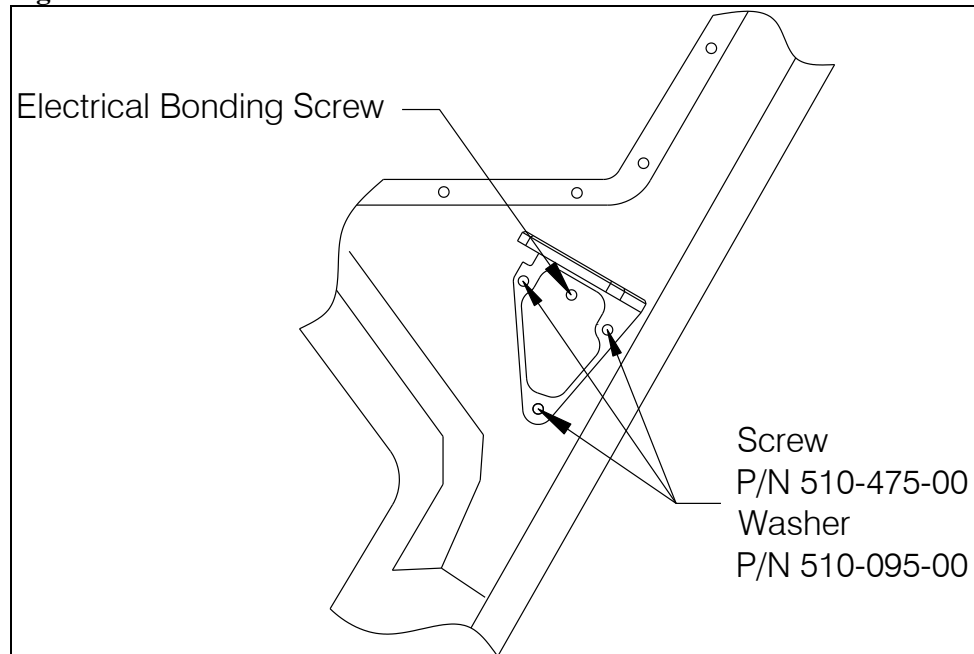

2.1 Cockpit Indicator Installation *continued*

Install C-39 Indicator (P/N 210-095-00) onto the bracket with hardware as illustrated below.

Figure 2.1.2 C-39 Indicator Bracket Installation

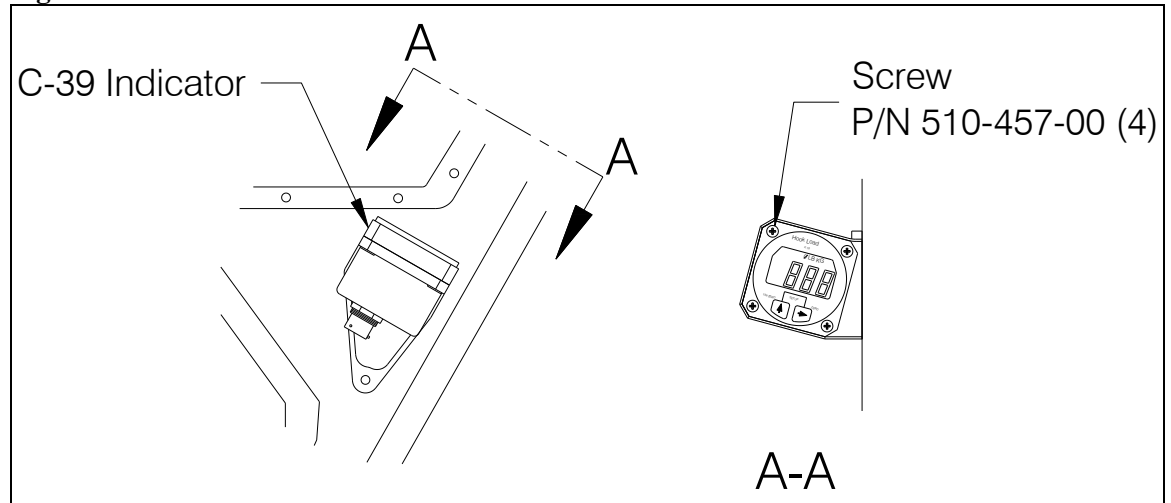

2.2 Electrical Wiring Installation

Remove existing swing suspension at the quick release pins. Remove lower fairings to gain access to areas underneath cabin floor where electrical wiring is routed. Remove existing Airbus Helicopters load weigh and hook release wiring harnesses.

Install electrical harnesses (P/N 270-106-02 and P/N 270-108-00) along the same route as the removed harnesses. Route (reference Figure 2.2.1) while observing the following precautions:

- Pick up existing wire runs by opening existing cable clamps. Nylon ties alone may not be used for primary support.
- The distance between supports should not exceed 21 inches.
- Bend radius of wire or harness must not be less than 10 times the wire or harness diameter.
- Inspect and verify that the wire harness may not be manually deflected into a structure with a bend radius of less than .13”.

Make the appropriate connections with contacts provided with harnesses. Secure the C-39 indicator harness (P/N 270-106-02) along the canopy with clamps and connect the C-39 indicator connector. Refer to Figure 2.2.7 for electrical wiring schematic.

The P/N 270-106-02 electrical harness includes a data line for use with an Onboard Systems Data Recorder or Analog Meter. These items are not included under this STC. Attach connectors to data line per pin out in Table 2.2.1 to connect the Analog Slave Meter or Data Recorder to the electrical harness “DATA” line. If a data connector is present on the data line use harness P/N 270-059-00 to connect to Analog Slave Meter. If the accessory connector is not used, stow this line of the harness.



The data line may or may not be terminated with a connector depending on manufacture date.

Table 2.2.1 Optional Equipment Connectors

Analog Meter Connector P/N 410-130-00 Mfg P/N: MS3126F10-6P		
Pin	Color	Function
A	WH	Power
B	WH/GN	Clock
C	WH/OR	Data
D	WH/BL	Ground
E	Shield	Shield

Data Recorder Connector P/N 410-011-00, 410-057-00 & 410-020-00		
Pin	Color	Function
1	WH/BL	Ground
3	WH	Power
5	Shield	Shield
7	WH/GN	Clock Signal
9	WH/OR	Data Signal
4	Red*	Flight Switch
2	Purple*	Cap. Switch

*Optional

2.2 Electrical Wiring Installation continued

Figure 2.2.1 Electrical Wiring Routing Overview

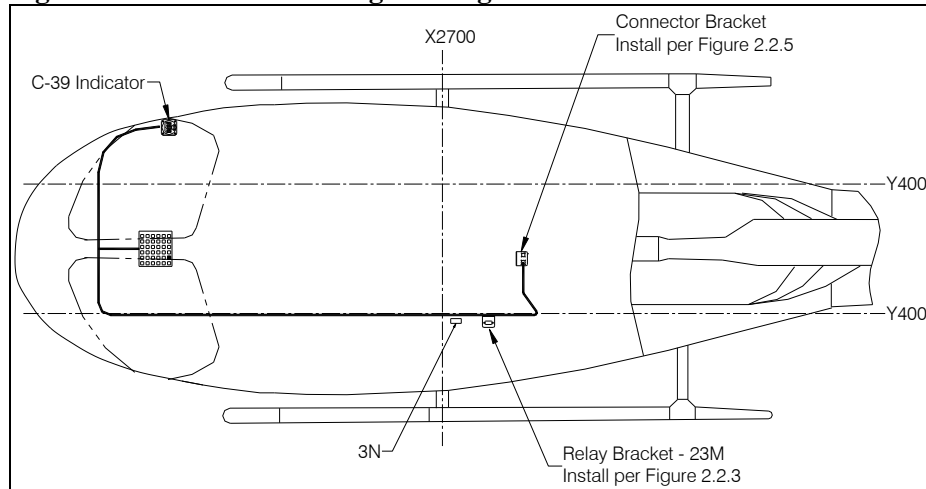

If installing the wire harnesses on a newer AS350B2 or B3 model equipped with a switch panel of circuit breaker design (Airbus Helicopters mod. #07-3274) the electrical harness P/N 270-108-00 requires a minor modification. Cut the ME1E wire off just prior to the butt splice and discard the splice and the 20 ga. wires.

Figure 2.2.2 P/N 270-108-00 Harness Modification

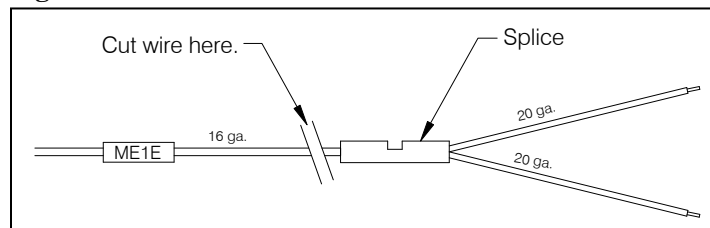

- ❑ Install Relay Bracket (P/N 290-783-00) using the same holes in the airframe as were used for the Airbus Helicopters relay. The location of these holes in the LH beam at Y400 is illustrated in Figure 2.2.3.

Figure 2.2.3 Relay Bracket Installation

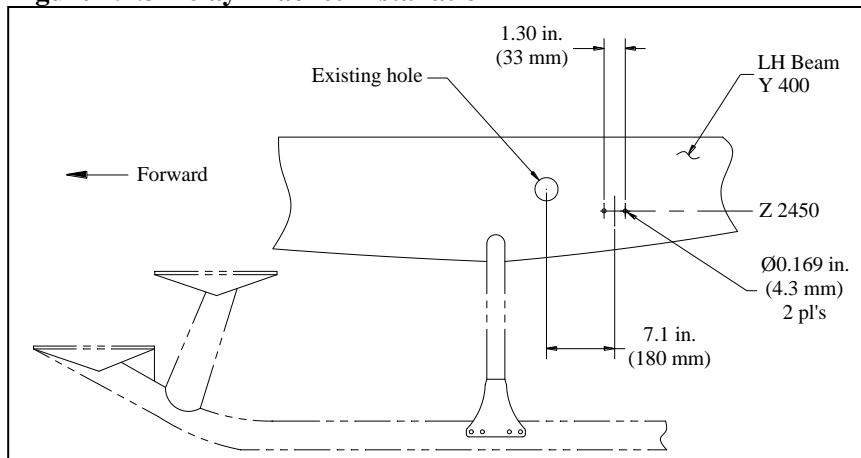

- ❑ Secure Relay Bracket with two screws (P/N 510-277-00), two washers (P/N 510-278-00), and two nuts (P/N 510-279-00).

2.2 Electrical Wiring Installation *continued*

- Place relay socket (part of 270-108-00 electrical harness) into relay bracket mounting holes from below and secure to relay and relay bracket with hardware provided with relay (as illustrated below).

Figure 2.2.4 Relay Installation

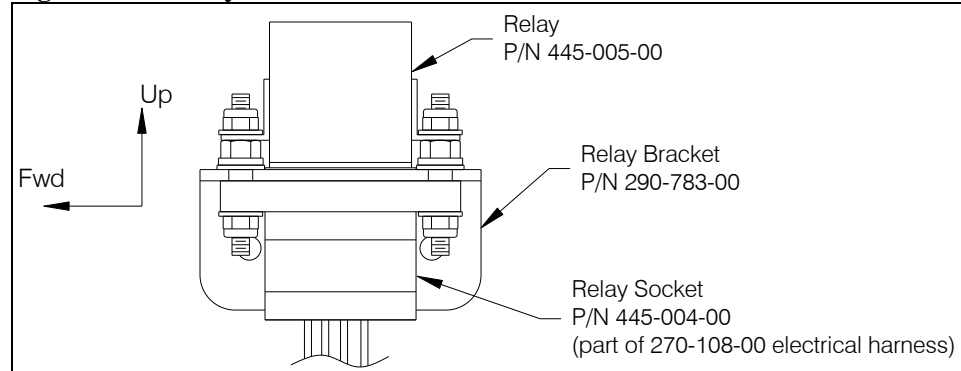

- Remove the existing connector bracket at the fuel tank support frame by drilling out the three rivets that secure it.
- Install Connector Bracket (P/N 290-782-00) using the same holes and rivet p/n as the removed bracket.

Figure 2.2.5 Connector Bracket Installation

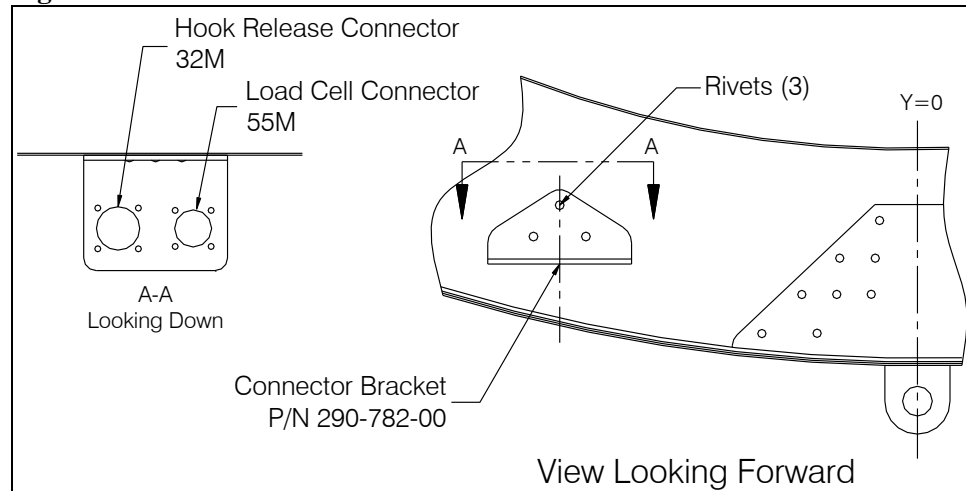

- Fasten hook release connector (32M) and load cell connector (55M) to the Connector Bracket with screws (P/N 510-481-00), washers (P/N 510-062-00), and nuts (P/N 510-029-00).

NOTICE

Install screws with their heads on the bottom side of bracket flange (if nuts are installed on bottom side they will interfere with mating connector).

2.2 Electrical Wiring Installation *continued*

Install the Ground Strap (P/N 270-125-00) terminal at the 3N grounding location at the LH airframe beam at Y400 per the following:

- ❑ Remove upper mounting hardware (see below) and retain.
- ❑ Prepare the surface for electrical bonding per Airbus Helicopters electrical bonding procedure. Refer to section 20.02.07 of the Airbus Helicopters Standard Practices Manual.
- ❑ Install ground strap terminal, re-using hardware.

Figure 2.2.6 Ground Strap Installation Location

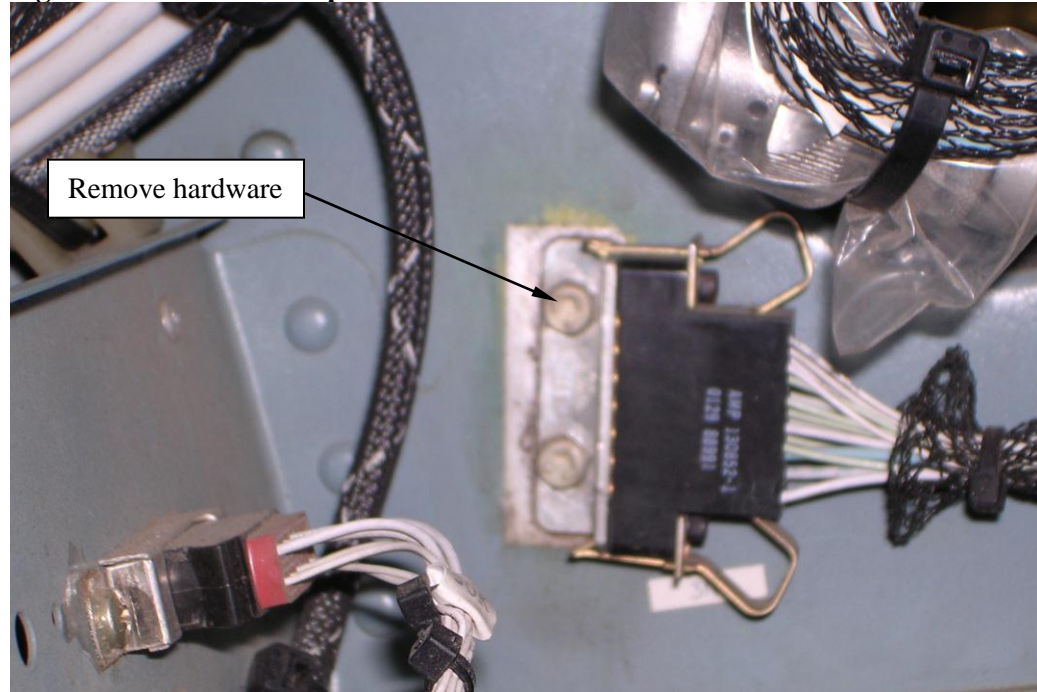

- ❑ Route the Ground Strap to the load weigh and electrical release harnesses installed previously and route with these harnesses, while securing with ty-wraps, to their termination points at the Connector Bracket.
- ❑ Route the Ground Strap around the Connector Bracket and position it such that the disconnect fitting at the end can be routed through the connector access hole and extended below the lower fairing (when installed).

2.2 Electrical Wiring Installation *continued*

The electrical schematic for the electrical release system and the load weigh system is shown below along with the aircraft's interface points. Airbus Helicopters modification #'s 07-4280 and 07-3450 are reflected below. Earlier Airbus Helicopters configurations which affected how and where wire numbers ME1E, ME2E and ME10E of the electrical release harness and load weigh harness interface with the helicopter are shown on the following page. Refer to the applicable Airbus Helicopters Wiring Diagrams Manual for additional information and for other cargo hook aircraft side wiring configurations that may not be shown.

For the C-39 Indicator backlighting, install wire 2LK71E to an available pin in the instrument panel or console lighting circuit (31L for pre-mod 07-4280), at 28 volts the indicator's internal bulb draws 25 mA.

If existing Airbus Helicopters cargo hook or load weigh wiring is installed and terminated at the locations below, remove the wires completely or remove from connectors and cap and stow them.

Figure 2.2.7 Wiring Schematic

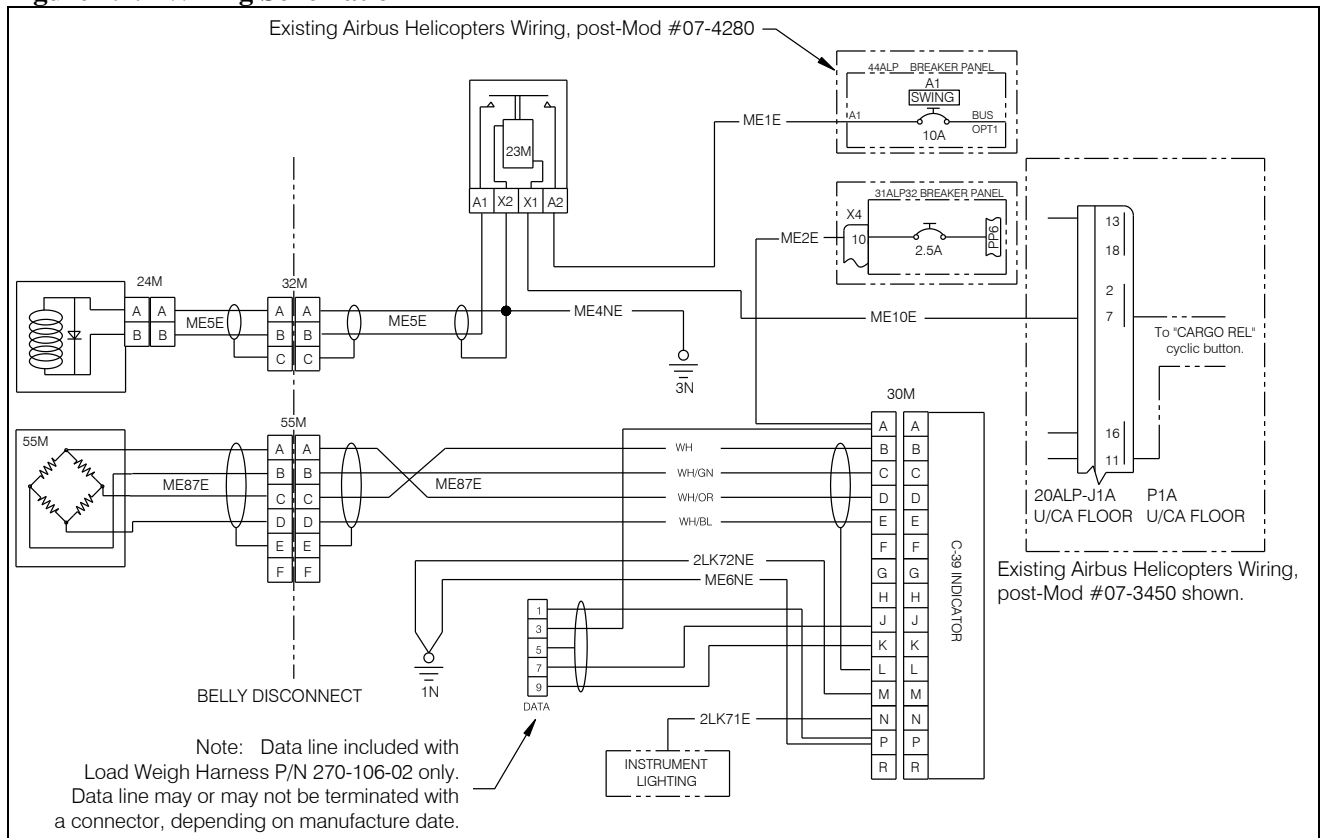

2.2 Electrical Wiring Installation *continued*

Figure 2.2.7 Wiring Schematic, *continued*

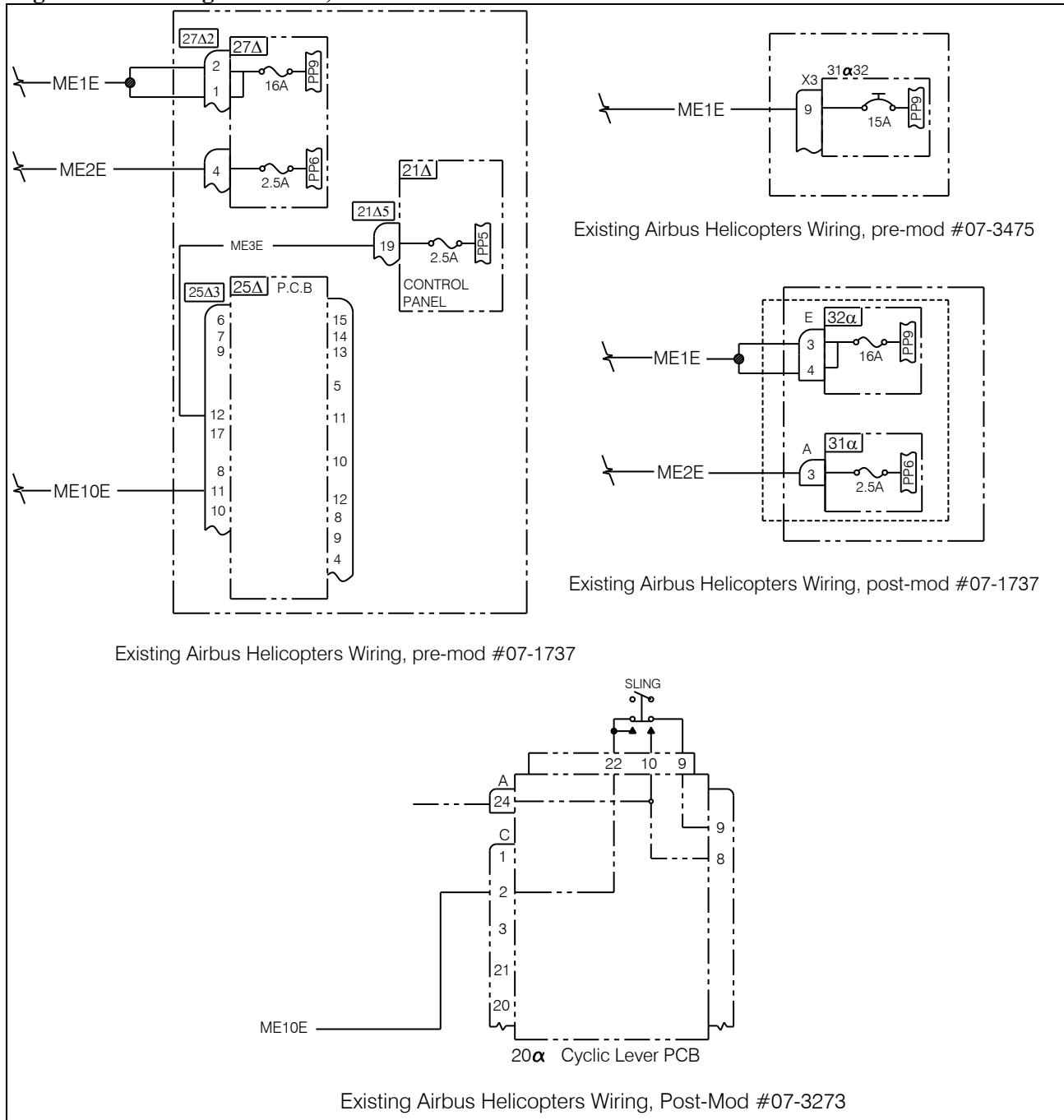

2.3 Fuel Drain Guard Installation

NOTICE

If installing the Swing Retrofit Kit on a helicopter that has NOT been retrofitted with the B-2 style dual fuel pump type tank (Airbus Helicopters P/N 350A55-1015-0251), the fuel drain guard installation is omitted. Skip to section 2.4.

In preparation for installing the fuel drain guard:

- ❑ Obtain ProSeal sealant (P/N PR1422-B).
- ❑ Verify that the fuel drain lever has been modified per AD 2005-03-08 requirements.
- ❑ Completely drain the fuel from the fuel tank.
- ❑ Begin disassembly of the fuel drain assembly by disconnecting the fuel drain control cable from the Lever (Airbus Helicopters P/N 350A55-1043-21). To free the control cable, remove the Sleeve (Airbus Helicopters P/N N1-5ALU) and Cable Grip (Airbus Helicopters P/N 58-2-009). See Figure 2.3.1.

Figure 2.3.1 Removing Control Cable

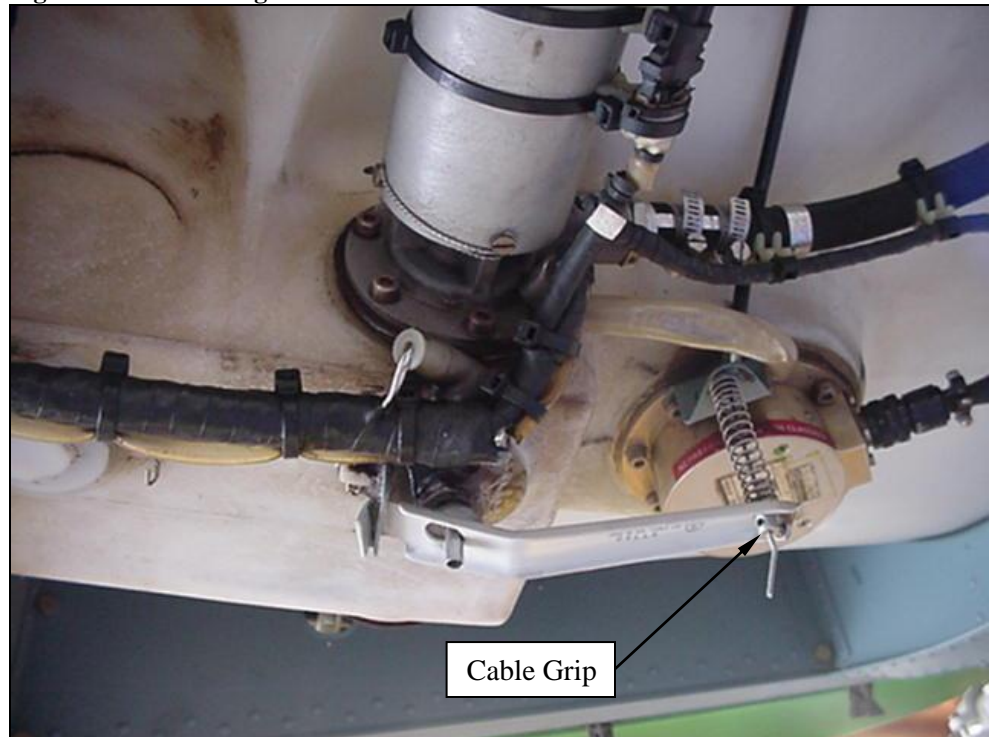

2.3 Fuel Drain Guard Installation continued

- ❑ Remove and retain spring (Airbus Helicopters P/N 350A55-1044-21) and Lever.
- ❑ Remove the cable support bracket. Retain the two attachment screws.
- ❑ Remove the connections from the common ground point on the lever retainer.
- ❑ Remove the safety wire securing the Fuel Drain Valve (Airbus Helicopters P/N 350A52-1008-01). Remove the Fuel Drain Valve and the Retainer from the tank. Discard used Fuel Valve Seal (Airbus Helicopters P/N SD16X-21P).
- ❑ Remove the residual sealant from the tank, taking care to not mar the sealing surface. Prepare the area for sealing per Airbus Helicopters Standard Practices Manual.

Figure 2.3.2 Fuel Drain Disassembly Complete

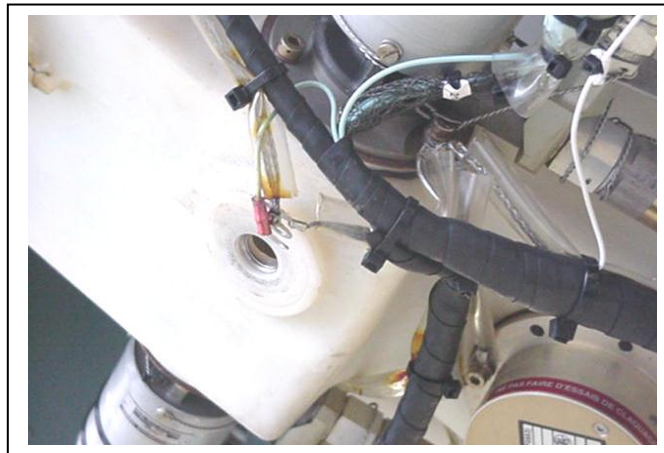

- ❑ Prepare the Retainer (P/N 290-888-00) for electrical bonding by removing anodize from the area shown in Figure 2.3.3.

Figure 2.3.3 Prepare Retainer

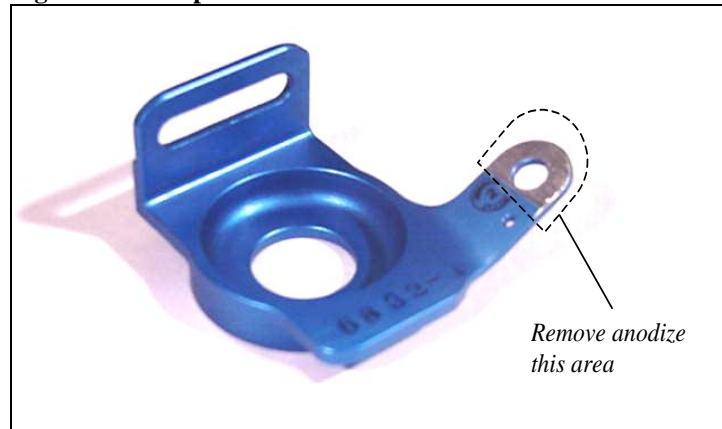

2.3 Fuel Drain Guard Installation *continued*

- Prepare PR1422-B or equivalent fuel tank sealant per Airbus Helicopters Standard Practices Manual. Apply sealant to Retainer as shown in Figure 2.3.4. Retain unused sealant to ensure proper cure.

Figure 2.3.4 Apply Sealant

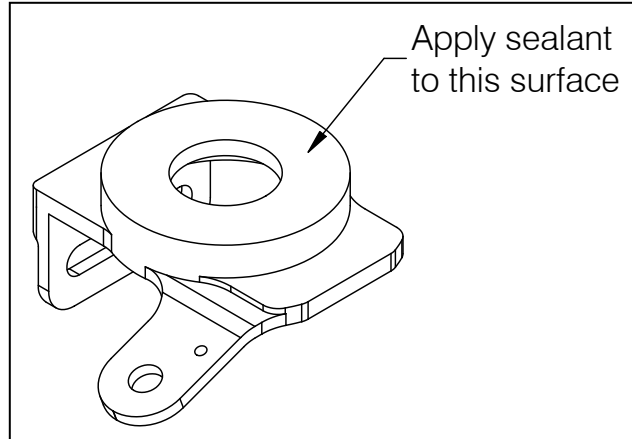

Figure 2.3.5 Position Guard



NOTICE

On some aircraft, the guard may have to be modified to fit the key on the fuel tank. In these cases, the sides of the clearance slot on the guard should be widened the minimum amount necessary in order to fit over the key. See figures 2.3.6 and 2.3.7.

2.3 Fuel Drain Guard Installation continued

Figure 2.3.6 Fuel Tank Key

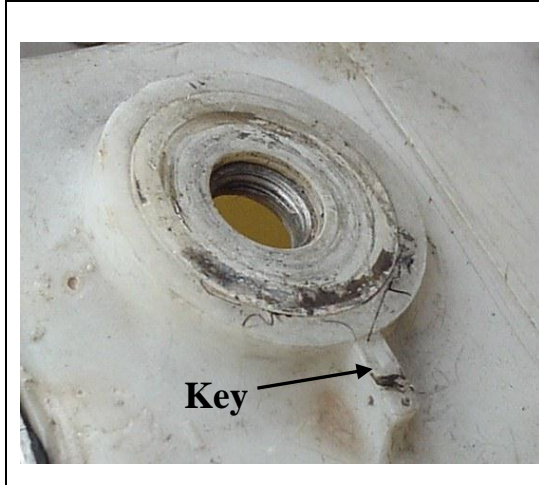
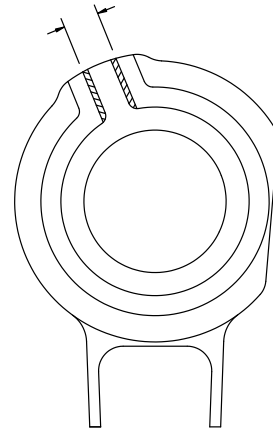

Figure 2.3.7 Modification of Guard Slot



- ❑ Carefully place the Retainer inside the Guard by inserting the tab through the slot in the Guard. Press the retainer to the tank firmly and center it about the drain hole. See Figure 2.3.8.

Figure 2.3.8 Retainer/Guard Assembly



- ❑ Secure the Guard and Retainer by re-installing the Fuel Drain Valve with Fuel Valve Seal, P/N 610-024-00 (Airbus Helicopters P/N SD16X-21P). Use a flat-blade screwdriver to prevent the Retainer from twisting when tightening the Fuel Drain Valve. Torque per Airbus Helicopters specifications.

NOTICE

The guard is not intended to fit tightly with the fuel tank. When properly installed, the guard should have freedom to move slightly.

2.3 Fuel Drain Guard Installation *continued*

- ❑ Secure the Fuel Drain Valve with safety wire using the small hole in the retainer tab.
- ❑ Re-install the electrical connections to the new Retainer tab per Airbus Helicopters Electrical Bonding Procedure. Refer to Airbus Helicopters Standard Practices Manual, 20.02.07.
- ❑ Install the Lever by placing it in Retainer slot and rotating upwards. Secure with cotter pin (P/N 510-526-00). See Figure 2.3.9.

Figure 2.3.9 Install Lever

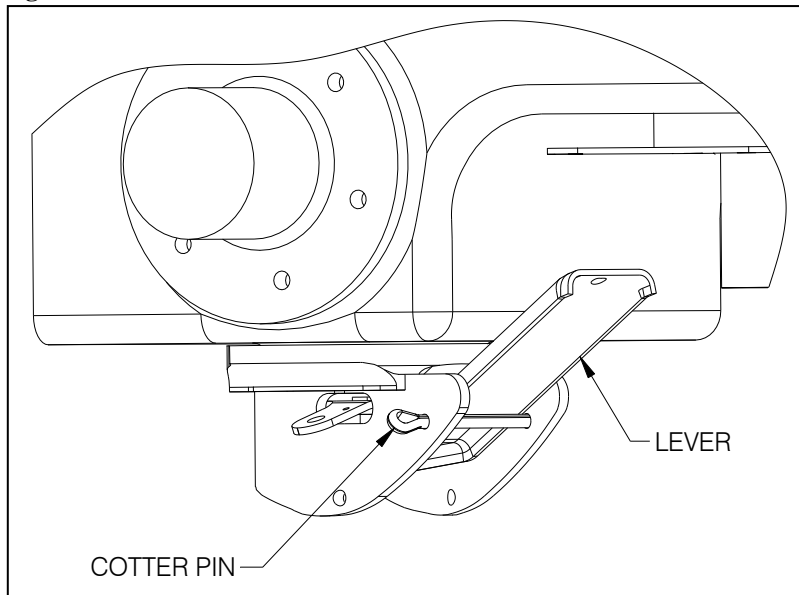

- ❑ Install a second cotter pin through the other holes in the Guard (this cotter pin is for valve protection only and is not used for rigging purposes).
- ❑ Prepare to install Bracket (P/N 290-893-00) by threading the control cable through the Bracket hole. Install Bracket using the two screws removed previously.
- ❑ Pass the cable through the spring and then the Lever. Install the Sleeve and Cable Grip.



To avoid inadvertent fuel loss, Airbus Helicopters P/N 58-2-009 Cable Grip must be used with this installation.

- ❑ Adjust the cable travel by doing the following: allow the lever to rest against the cotter pin stop. Slide the Cable Grip up to the bottom of the lever and secure. See Figure 2.3.10.

2.3 Fuel Drain Guard Installation continued

Figure 2.3.10 Adjust Cable Travel

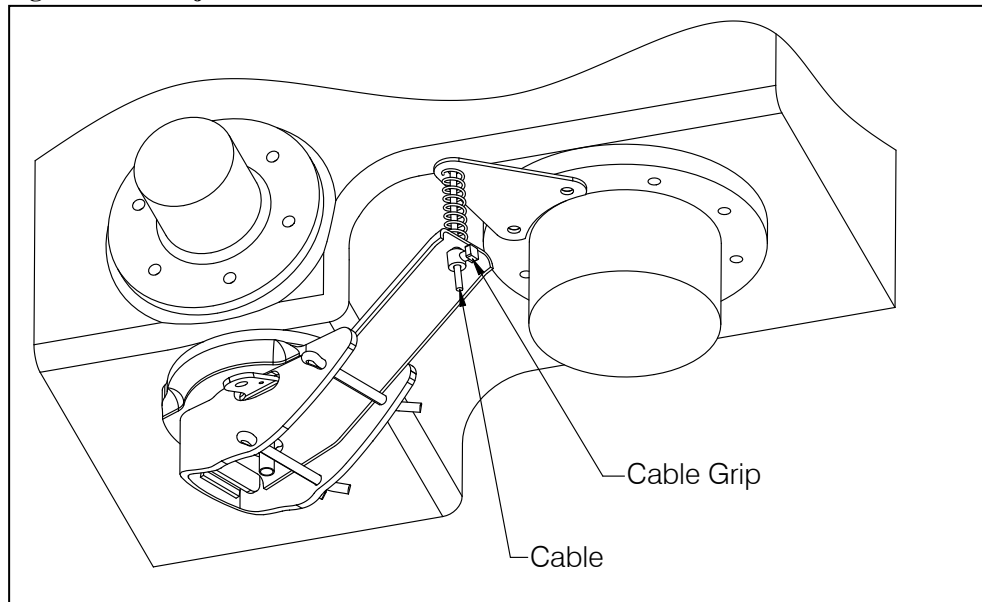

- ❑ Check the cable adjustment with the release handle on the side of the aircraft. There should be a minimum of .25 inch (6mm) cable travel before valve opens. Adjust the Cable Grip as required.
- ❑ Allow the sealant to cure per Airbus Helicopters Standard Practices Manual before adding fuel. Verify proper cure of unused sealant.
- ❑ Add fuel to the tank and check for leakage.
- ❑ Reinstall aft lower cowling. Check for clearance between Guard and cowling. If required trim cowling cutout to provide a min of .125 inch (3.5mm) clearance between the cowling and guard. See Figure 2.3.11 for completed installation.

Figure 2.3.11 Installation Complete



2.4 Swing Suspension Installation

2.4.1 Shackle Assembly Installation

- If necessary, install the landing gear half clamps per Airbus Helicopters modification 07-2772.
- Remove the existing Airbus Helicopters shackles (if present) and install the four Shackle Assemblies (P/N 232-137-01) onto the landing gear half clamps with hardware as illustrated in Figure 2.4.1.1 (Airbus Helicopters part numbers are shown in italics). At the RH forward half clamp remove and re-install the existing manual release cable support bracket at the inboard side as illustrated in Figure 2.4.1.2. Torque the nuts to 100-130 in-lbs.

Figure 2.4.1.1 Shackle Assembly Installation

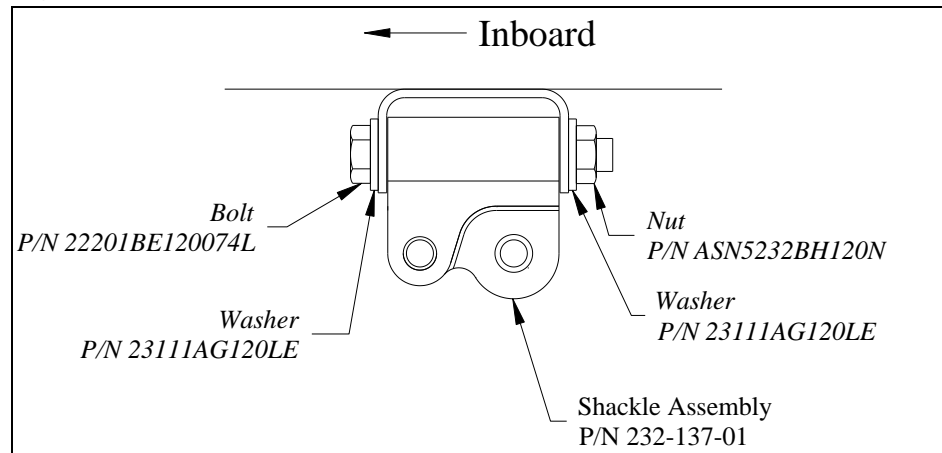
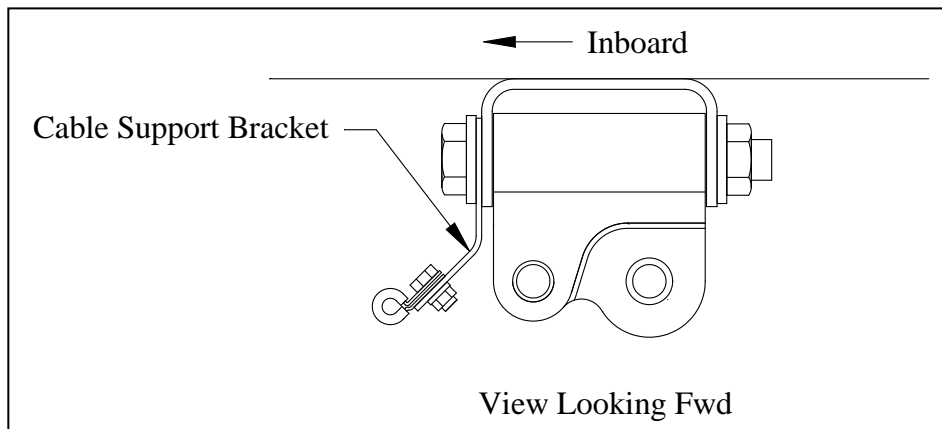

Figure 2.4.1.2 RH Forward Shackle Assembly Installation



2.4 Swing Suspension Installation *continued*

2.4.1 Suspension Installation

- ❑ Install the cable assemblies onto the swing suspension frame with hardware provided pre-assembled onto the cable clevis end. Fasten the two shorter cable assemblies (P/N 232-140-01) onto the forward pivot points* of the suspension frame and the two longer cable assemblies (P/N 232-141-01) to the aft pivot points. Torque the castellated nuts on the pivot bolts to 20 ft-lbs., then rotate nut to next castellation, not to exceed 30 ft-lbs. Install and secure cotter pins.

*The forward end of the suspension is determined by the orientation of the cargo hook. **When the suspension is installed the cargo hook load beam must point to the left side of the helicopter** (the manual release cable is routed to the right side of the helicopter).

- ❑ Install the Swing Suspension onto the aircraft by attaching the four clevises at the end of the cables to the inboard holes on the Shackle Assemblies with the quick release pins as shown in Figure 2.5.1. Install the attached safety pins at each quick release pin.

Figure 2.4.2.1 Suspension Cable Attachment

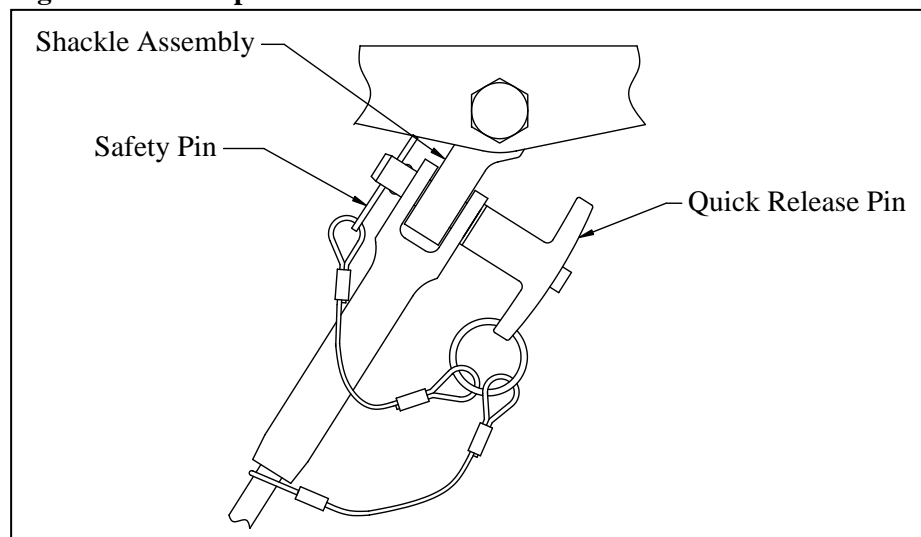

2.5 Removable Manual Release Cable Assembly Installation

Connect the removable manual release cable (P/N 268-024-02) to the cargo hook first, per the following instructions:

- ❑ Remove the manual release cover from the cargo hook. Thread the fitting at the end of the manual release cable into the manual release boss on the hook side plate until the threads protrude approximately .125" (3.2mm) beyond the boss and secure with jam nut (as shown in Figure 2.5.1).
- ❑ Leave the cover off of the cargo hook until the other end of the release cable is connected, in order to verify proper setting.

Figure 2.5.1 Manual Release Cable Fitting Adjustment

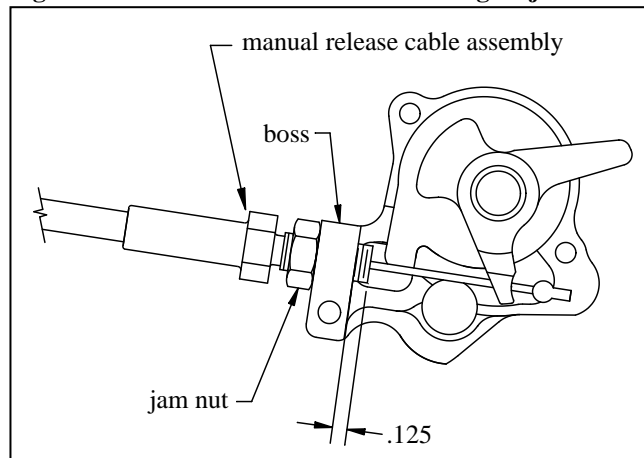

- ❑ Route the cable from the hook to the fixed manual release cable through two existing clamps as illustrated below. These clamps must be located at the two furthest forward positions on the lower cowling (points 1 and 2 in Figure 2.5.2 below). Do not use the clamp at the aft position.

Figure 2.5.2 Manual Release Cable Routing

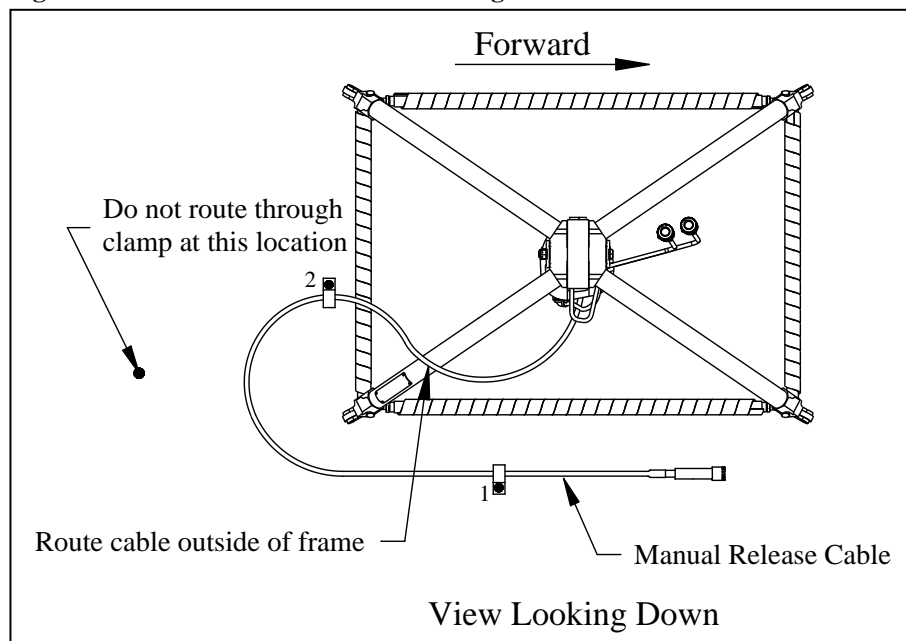

2.5 Removable Manual Release Cable Assembly Installation *continued*

- ❑ Connect the other end of the removable cable assembly to the end of the fixed cable by sliding the Adapter Fitting back to expose the swaged cable end fitting and connecting this fitting to the swaged cable end fitting on the fixed cable as shown below.
- ❑ Thread the Adapter Fitting on the removable cable onto the fixed cable adapter fitting and lock in position by engaging a castellation with the locking pin.
- ❑ Snap the removable cable Adapter Fitting into the inboard spring clip on the bracket on the lower RH fairing.

Figure 2.5.3 Manual Release Cable Connection

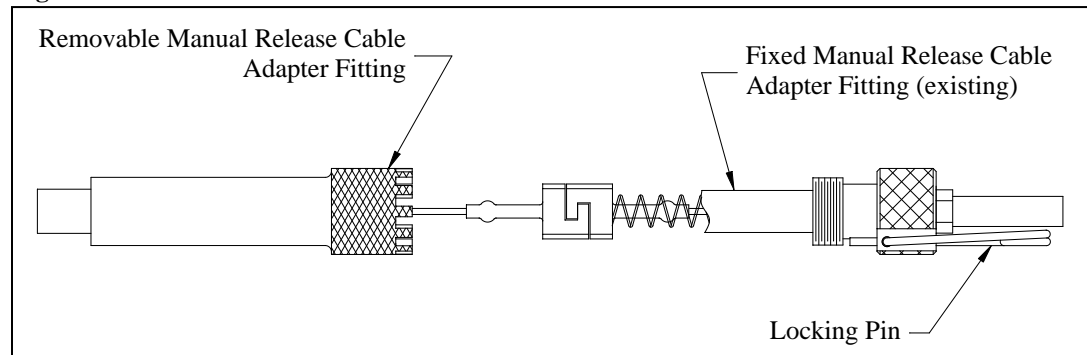

2.5 Removable Manual Release Cable Assembly Installation *continued*

Verify proper setting at the hook:



Manual release cable rigging must be done with the cargo hook in the closed and locked position.

- Place the cable ball end fitting into the hook manual release fork fitting as illustrated in Figure 2.5.4. Move the manual release lever in the clockwise direction until it is against the cam stop. Measure the cable ball end free play with the manual release handle in the cockpit in the non-release position. The gap should measure a minimum of .125" (the maximum gap is limited by the manual release cover, i.e.- it must fit inside the cover).

If the gap does not measure at least .125", make adjustments at the hook only. This is done by disconnecting the cable at the interface with the fixed manual release cable (Figure 2.5.3), loosening the jam nut, and rotating the cable in the required direction.

Figure 2.5.4 Manual Release Cable Rigging

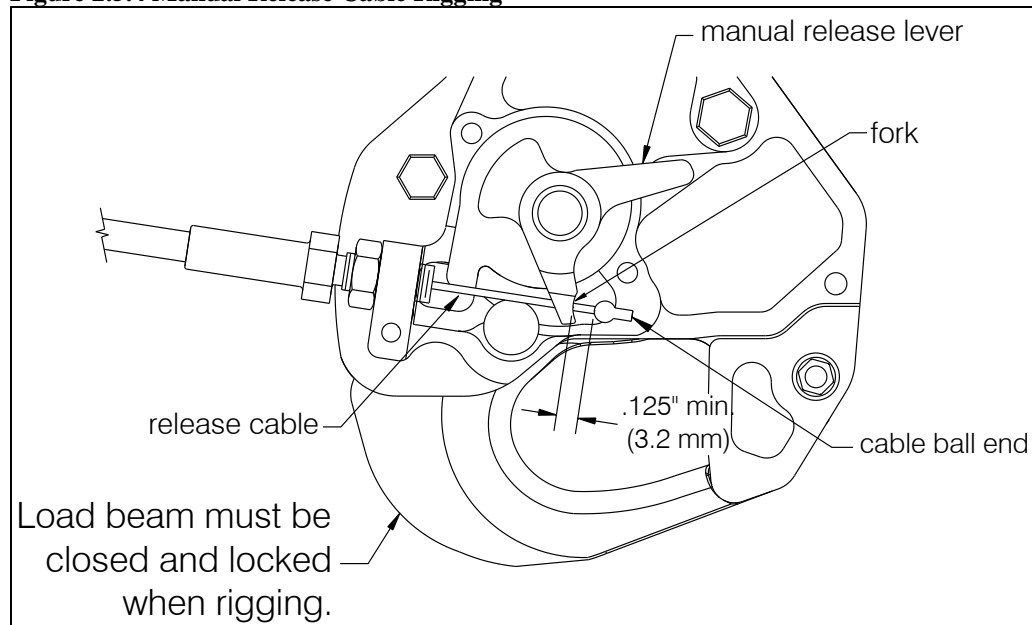

- Move hook and swing frame throughout its range of motion while observing free play. At no point should the free play be less than .030" (.8 mm). Also, check that the cable housing is not kinked or pulled tight in any position.
- Verify proper release travel by pulling manual release lever in cockpit and ensuring that there is sufficient travel to open hook fully.
- Replace the manual release cover on the hook and safety wire screws.
- Connect the end of the cargo hook electrical release cable to the fixed electrical release connector (32M) installed per Section 2.2.

2.6 External Electrical Cable Installation

- ❑ Connect the Ground Strap from the hook to the fixed ground strap installed per section 2.2.
- ❑ Connect the end of the load cell cable to the fixed load weigh harness connector (55M) installed per Section 2.2.
- ❑ See table 2-2 for connector pin out information.

Table 2.2 Cargo Hook Connector

Pin	Function
A	Ground
B	Power

CAUTION

The cargo hook is equipped with a suppression diode that will be damaged if the cargo hook electrical connection is reversed.

WARNING

Un-commanded cargo hook release will happen if the manual release cable is improperly restrained. The cable must not be the stops that prevent the Cargo Hook from swinging freely in all directions. If the Cargo Hook loads cause the hook to strain against the manual release cable the swaged end of the cable may separate allowing the inner cable to activate the cargo hook manual release mechanism. The result is an un-commanded release. Ensure that no combination of cyclic stick or Cargo Hook position is restrained by the manual release cable.

Figure 2.6.1 Un-commanded Release From Incorrectly Secured Cable

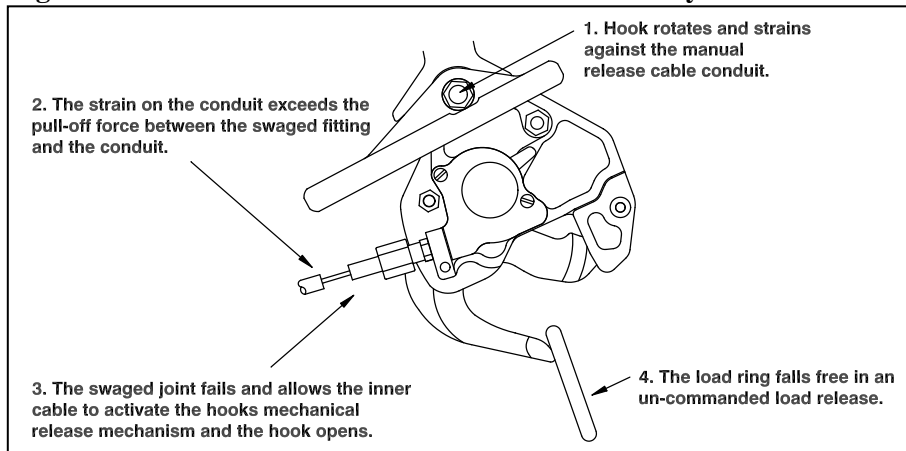

Installation Check-Out

After installation of the Cargo Hook Swing Suspension System, perform the following functional checks.

1. Swing the installed Cargo Hook on the suspension to its full extremes to ensure that the manual release cable assembly and the electrical release cable have enough slack to allow full swing of the cargo hook assembly without straining or damaging the cables. The cables must not be the stops that prevent the Cargo Hook from swinging freely in all directions.
2. Swing the Suspension to its full extremes to ensure that the manual release cable assembly and the electrical release cable have enough slack to allow full swing of the Suspension without straining or damaging the cables. The cables must not be the stops that prevent the Suspension from swinging freely in all directions.
3. With no load on the cargo hook load beam, pull the handle operated cargo hook mechanical release, the Cargo Hook should release. Reset the cargo hook load beam.
4. With no load on the cargo hook load beam, depress the cargo hook electrical release button, the Cargo Hook should release. Reset the cargo hook load beam.
5. Perform an EMI ground test per AC 43.13-1b section 11-107. For equipment that can only be checked in flight an EMI flight test may be required.



The cargo hook is of a class of equipment not known to have a high potential for interference. This class of equipment does not require special EMI installation testing (i.e. FADEC) as required in paragraphs 7 and 8 of FAA policy memorandum ASW-2001-02.

6. Power on the Indicator and allow it to warm up for 5 minutes (with no load on the hook). Press both Indicator buttons at the same time to go to the Setup Mode. Scroll through the menu until the symbol “0 in” is displayed, then press the right button. Remove any weight that is not to be zeroed out and press either button to complete the procedure.
7. If fuel drain guard was installed, pull the handle on the side of the helicopter and verify that fuel is dispensed from the valve.

Component Weights

The weights and cg locations of the system components are listed below.

Table 2.3 Component Weights and CGs

Item	Weight	Station
Fixed Provisions	4.9 lbs (2.2 kgs)	110 in (2794 mm)
Removable Provisions	30.0 lbs (13.6 kgs)	133 in (3375 mm)
Total	34.9 lbs (15.8 kg)	130 in (3302 mm)

Paper Work

In the US, fill in FAA form 337 for the initial installation. This procedure may vary in different countries. Make the appropriate aircraft log book entry. Insert the Rotorcraft Flight Manual Supplement P/N 121-015-01 into the rotorcraft flight manual.

Section 3

Load Weigh System Operation Instructions

Indicator Front Panel

The C-39 Indicator front panel includes the following features.

- The four 7 segment LCD digits show the weight on the Cargo Hook and display various setup information.
- The Legends clarify the digital display, i.e. - when the LB Legend is turned on, the display will be pounds, etc.
- The right button is used to Zero the display in the Run Mode and select the digit to be changed in the Setup Mode.
- The left button is used to Un-Zero the display in the Run Mode and scroll the selected digit in the Setup Mode.

Figure 3.1 Front Panel

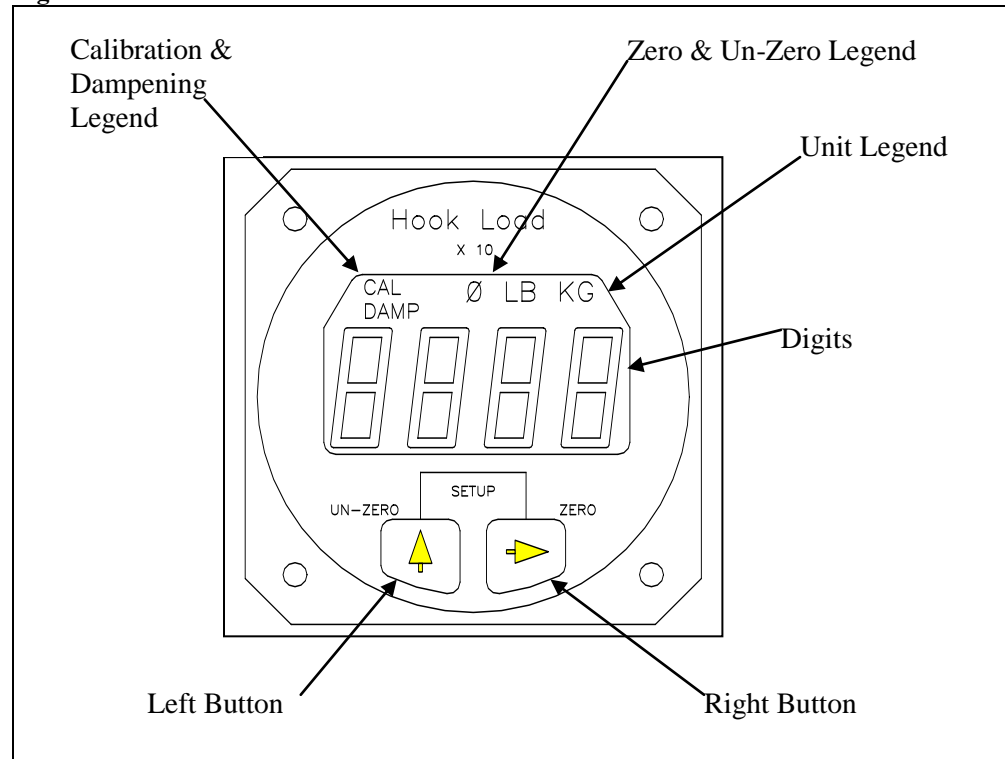

The Run Mode

The C-39 Indicator has two operating modes, Run and Setup. The Run Mode is used to display the cargo hook weight and the Setup Mode is used to setup or configure the Indicator to the helicopter and to the Load Cell. When powered up, the Indicator always comes on in the Run Mode.

After the Indicator has been correctly installed, power it up by activating the aircraft electrical system. The Indicator will go through a self-diagnostic routine. During this routine the display will display all of the digits and legends. If a problem is found during the routine an Error Code will be displayed. For an explanation of Error Codes see the section *Error Codes*. After the diagnostic routine the display should look like this:

Figure 3.2 After Diagnostic Routine

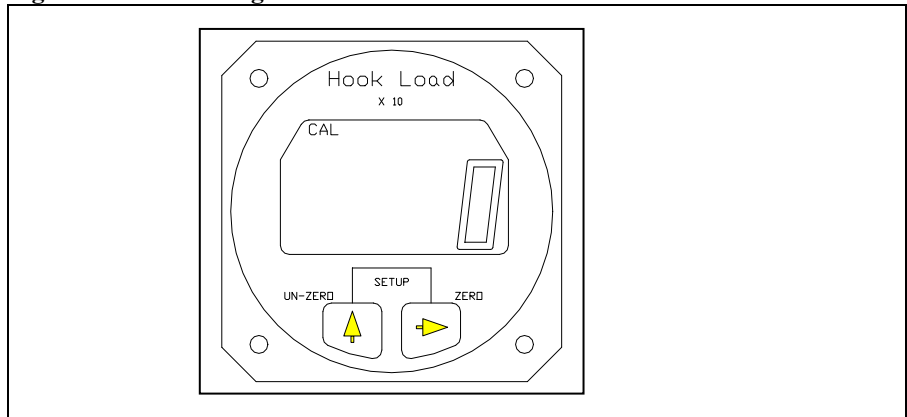

The illustration is of the Indicator in the Run Mode with no load on the hook. Note the LB legend displayed.

Figure 3.3 LB Legend Displayed

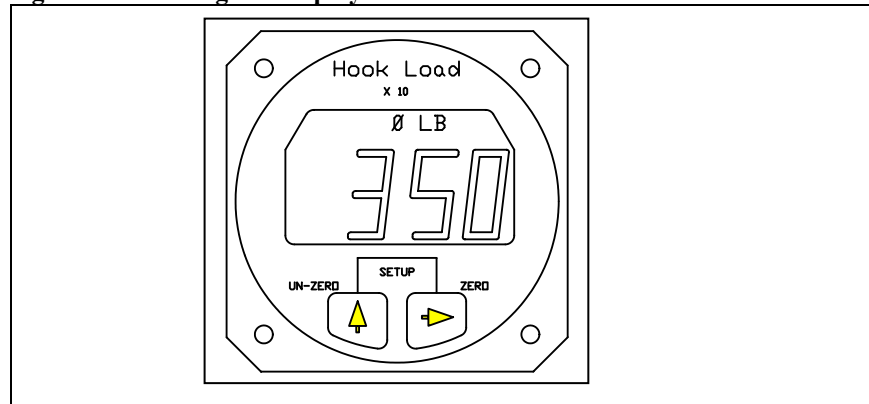

The illustration is a typical hook load reading. The display is 3,500 pounds, note the last digit is not displayed.

The Run Mode *continued*

To Zero or Tare the Display

The zero feature is used to zero or tare the weight on the Cargo Hook that is not wanted, such as the weight of a cargo net or long line. The Right button is used to zero the Indicator reading. When the Right button is pressed the display is zeroed. The zero legend is turned on and the zeroed number is stored in memory. If the Right button is pressed again, before the Un-zero button is pressed, the display blinks in response to the button closure. Zero is only available in the Run Mode.

Figure 3.4 Zeroing the Display

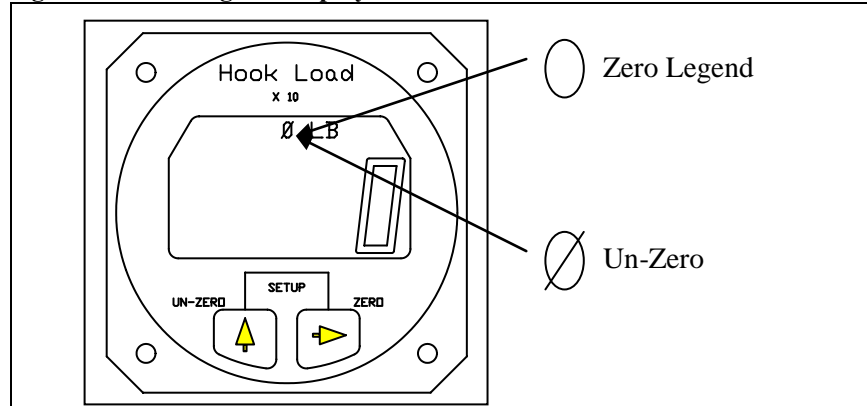

To Un-Zero the Display

The Left button is used to add the zeroed value back into the current Indicator reading or Un-zero the display. When the Left button is pressed, the number previously zeroed is added to the current display and the Un-zero legend is turned on. If the Left button is again pressed before the zero button is pressed, the display blinks in response to the button closure. Un-Zero is only available in the Run Mode.

The Run Mode continued

Error Codes

Error Codes are the result of difficulties discovered during the Indicator diagnostic tests. Diagnostic tests occur at power up and during the execution of certain routines. Listed below is a matrix of the Error Code displays, their meaning and possible corrective action. Pressing either button will usually bypass the error code, however, the displayed information may be suspect.

Table 3.1 Indicator Error Codes

DISPLAY	CAUSE	POSSIBLE CORRECTIVE ACTION
Err 1	A/D or D/A circuit failure	Potential short in the optional analog meter cable. Clear short and power cycle the Indicator by turning the power to the Indicator off for a few moments. If Error Code continues, return the Indicator to the factory.
Err 2	NV Ram failure	Power cycle the Indicator; if Error Code continues, return the Indicator to the factory.
Err 3	NV Ram write failure	Re-enter data, if Error Code continues, return the Indicator to the factory.
Err 4	NV Ram busy failure	Power cycle the Indicator, if Error Code continues return the Indicator to the factory.

The Setup Mode

The C-39 Indicator can be used with a wide range of helicopters and load cells. The Setup Mode on the Indicator matches the Indicator to the Load Cell and to the helicopter. This is done by entering data into the Indicator. Entered data includes the load cell Calibration Code, the units that the Indicator should read-out (pounds or kilograms), and several other items.

The Indicator has a group of Setup routines, arranged in menu form, that are used to configure the Indicator. Shown on the next page is a matrix of the Setup routines and a brief discussion of their function and how they are programmed. A complete discussion of each setup item is presented later in this section.

To enter the Setup Mode press both the Right and Left buttons at the same time while the Indicator is powered up and in the Run Mode. To exit the Setup Mode and return to the Run Mode, press both the buttons at the same time. If you are in a Setup routine and have started to change an entry, but you change your mind before completing the procedure, power cycle the Indicator to exit the Setup Mode and then go to the Run Mode without changing the item. The Indicator is power cycled by turning the Indicator power off for a few moments.

The Setup Mode continued

Table 3.2 Indicator Setup Routines

MENU	FUNCTION	DISPLAY
Press the Left button to scroll through the menu	Press the Right button to view or change the menu item.	To return to the Run Mode press both the Right and Left buttons at the same time.
DAMP	<u>Dampening Level</u> , sets the pilots preference for display dampening.	Blinking display is previously entered Dampening Level. Select the desired dampening level by pressing the Left button.
CODE	<u>Calibration Code</u> , matches the Indicator to the Load Cell.	Display is previously entered CAL Code. The Code is changed by selecting the digit to be changed with the Right button. The selected digit will blink. Change the blinking digit by pressing the Left button.
0 in	<u>Installation ZERO</u> , matches the Indicator to the installed Load Cell and to the helicopter. After this procedure the display will be zero when no load is on the Cargo Hook.	Display is a combination of load on the Load Cell, and normal load cell zero offset. Remove all weight from the installed Load Cell except the Cargo Hook, and press any button to complete the procedure and return to the Run Mode.
LOAD	<u>Load</u> , is used to calibrate the system by lifting a known load.	No previous display is shown. Enter the known load using the Right button to select the digit to be changed and Left button to enter the number. Known load is entered "X 10" i.e.; 5000 kilograms is entered as 500. After the known load is entered, press both buttons at the same time and lift the known load. When the load is stabilized press either button. A new Calibration Code will be calculated and the known load will be displayed. This completes the procedure.
Scale	<u>Scale</u> , matches the analog output of the Indicator to an optional remote analog meter.	Display is previously entered number. To change the number use the Right button to select a digit, use the Left button to scroll the digit to the desired number. Entry is times 10.
LB KG	<u>Units</u> , selects the Indicator units (pounds or kilograms).	Display is previously selected unit. To change the unit, use the Left button.
XX - V	<u>Version</u> , is the revision level of the Indicator hardware and software.	Version is for information only, it cannot be changed.

The Setup Mode *continued*

Indicator Dampening

The Damp or dampening routine allows the pilot to adjust the Indicator dampening level to his preference. The dampening routine is a program that stabilizes the Indicator reading. It offers a trade-off between Indicator responsiveness and stability. Ten dampening levels are available, from 0 through 9. At level 0 the display responds to the slightest change in weight. However, if the load bounced even slightly, the display digits would respond instantly, making the display look unstable. With a dampening level of 9, the display would be stable under the most turbulent conditions, however, it would take several seconds for the display to respond to a change in weight. The ideal dampening level will depend on the flying conditions. A mid range setting of 5 or 6 is usually adequate.

To Look at or Change the Dampening Level

With the Indicator powered up and in the Run Mode, press both buttons at the same time to go to Setup. Scroll through the menu, using the Left button, until the word DAMP is displayed. To look at or change the Dampening Level press the Right button. The display should look like this:

Figure 3.5 Changing Dampening Level

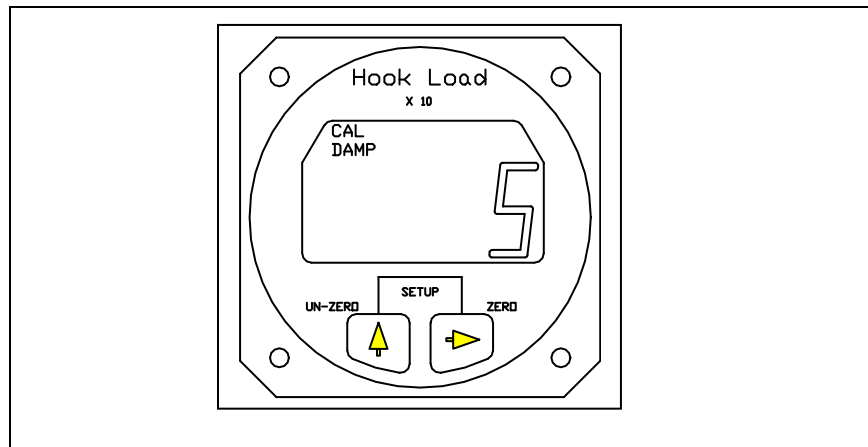

The CAL and the DAMP legend is turned on and the previously set dampening level is displayed. To return to Run without changing the current dampening level press both the Right and Left buttons at the same time. To change the dampening number, use the Left button to scroll the blinking digit to the desired number. After the selection has been made press both the Right and Left buttons at the same time to return to Run.

The Setup Mode continued

Indicator Calibration

The Calibration Code, or CAL code, is a mandatory input. The Indicator will not accurately display the load without the correct Calibration Code. The Calibration Code scales the signal from the Load Cell.

If the C-39 Indicator was supplied as part of a Load Weigh System, the Calibration Code will have been entered into the Indicator by the factory, however, it should be confirmed. If the Indicator is to be mated to a different Load Cell, it must be calibrated before use. Calibration can be done by entering a known Calibration Code or by lifting a known load and having the Indicator calibrate itself. Both options are discussed below.

To Look at or Change the Calibration Code

With the Indicator powered up and in the Run Mode, press both buttons at the same time to go to Setup. Scroll through the menu until the word CODE is displayed, then press the Right button. The display should look like this:

Figure 3.6 Changing the CAL Code

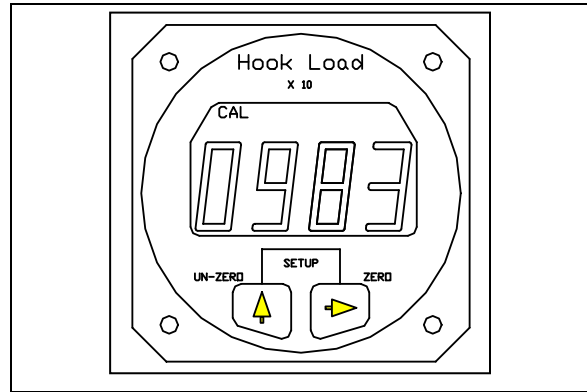

The CAL legend is turned on and the previously entered or computed Calibration Code is displayed. To return to Run without changing the CAL Code, press both the Right and Left buttons at the same time. To change the Calibration Code, use the Right button to select the digit to be changed, then use the Left button to scroll the blinking digit to the desired number. When the Calibration Code has been entered, press both the Right and Left button at the same time to return to Run.

NOTICE

Depending on the type of Load Cell, the Calibration code could be a 3 or 4 digit number. If the Calibration Code is a 3 digit number a leading zero (0) must be used. For example if a Load Cell had a CAL Code of 395 it would be entered as 0395.

If the load cell Calibration Code is not known or as a cross check, the Indicator can generate the Calibration Code. This is done by entering the weight of a known load into the Indicator LOAD routine and then lifting the load. See the section *Calibration by Lifting a Known Load*.

The Setup Mode continued

Installation Zero

Installation zero is a routine that matches the Indicator to the ***INSTALLED*** Load Cell. It adjusts the Indicator reading to compensate for the weight of the Cargo Hook on the Load Cell and whatever zero offset is built into the Load Cell. The Installation Zero procedure is not mandatory. If done the Indicator will read zero when the Un-Zero button is pressed and there is no weight on the Cargo Hook. If the Installation Zero is not done, the Indicator will show the weight of the Cargo Hook plus the value of the Load Cell zero offset.

To Run the Installation Zero Routine

With the Indicator powered up and in the Run Mode, press both buttons at the same time to go to Setup. Scroll through the menu until the symbol "0 in" is displayed, then press the Right button. The CAL legend will be turned on and the current weight on the Cargo Hook will be displayed and blinking. Remove any weight that is not to be zeroed out and press either button to complete the procedure and return to the Run Mode.

Calibration by Lifting a Known Weight

Calibration by lifting a known weight is a Setup routine that calculates the Calibration Code for the Load Cell attached to the Indicator. It is useful if the load cell Calibration Code is not known or as a cross check to the accuracy of a known Calibration Code. The procedure is done by entering the known weight into the Indicator and then lifting the weight. This procedure can be done in the shop or on the helicopter. The accuracy of the procedure is directly related to the weight of the known load. If for example the procedure was done with a 1,000 pound load that was assumed to weigh only 900 pounds, all subsequent lifts would be displayed 10% light.



Be sure to include the weight of everything between the Cargo Hook and the load, i.e. the cable, net, dirt, etc.

The closer the known load approaches the lifting capacity of the helicopter, the more accurate the calculated Calibration Code will be.

The Setup Mode continued

To Run the Calibration by Lifting a Known Weight Routine

With the Indicator powered up and in the Run Mode, press both buttons at the same time to go to Setup. Scroll through the menu until the word LOAD is displayed, then press the Right button. The display should look like this:

Figure 3.7 Running CAL Routine

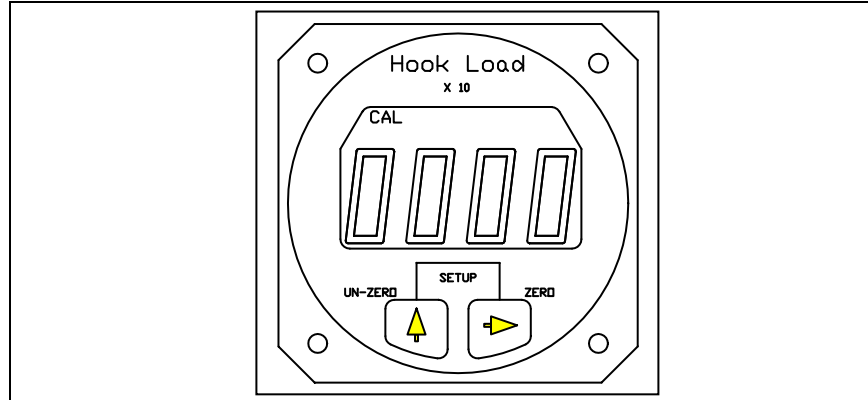

The CAL legend is turned on and the first digit is blinking. The previous load is not displayed. At this point if you wish to return to the Run Mode without changing the Calibration Code, power cycle the Indicator. At this point it is not possible to return to the Run Mode without changing the Calibration Code by using the buttons on the Indicator front panel.

To proceed with the procedure, use the Right button to select the digit to be changed, then use the Left button to scroll the blinking digit to the desired number. Note that the known weight is entered "X 10"; a 1000 pound load is entered as 100. When the known load has been entered, press both the Right and Left button at the same time. The display will look like this:

Figure 3.8 Entering Load in CAL Routine

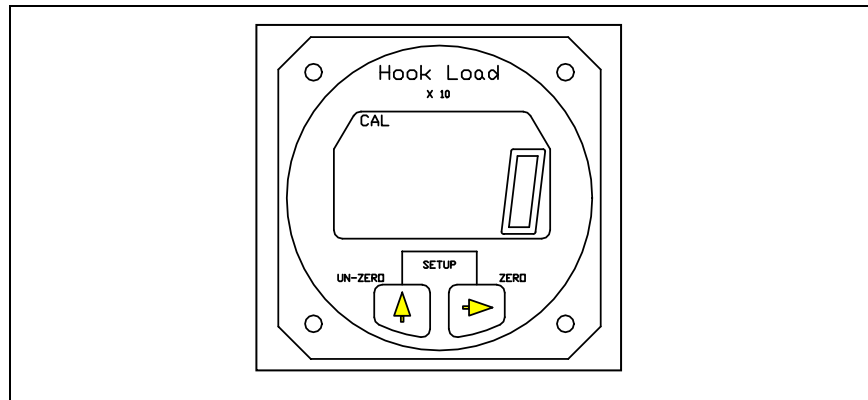

The Setup Mode, continued

Calibration by Lifting a Known Weight, continued

The CAL legend and the digits will be blinking. Again, at this point if you wish to return to the Run Mode without changing the Calibration Code, power cycle the Indicator. It is not possible to return to the Run Mode by using the buttons on the Indicator front panel without changing the Calibration Code. If you wish to proceed, lift the known load and when it is stabilized, press either button to complete the procedure. The Indicator will display the load. This ends the procedure. The Indicator is now calibrated to the Load Cell. It is a good practice to go to the Code routine and record the new Calibration code for later reference.

Setting the Scale for a remote analog meter

The Scale routine is used when a user supplied analog meter is connected to the Indicator. It is used to match or calibrate the analog meter to the Indicator. The Indicator outputs a 0 to 5 VDC analog signal which is proportional to the Load Cell load. The Scale number tells the Indicator at what point in pounds or kilograms it should reach the 5 VDC output. If for example a 5 volt analog meter is used and its full scale reading is 10,000 pounds, the number entered into the Indicator Scale routine would be 1000 (the number is entered X 10). This number tells the Indicator that it should output the proportional 0 to 5 VDC signal between zero pounds and 10,000 pounds.

The Scale number does not affect Onboard Slave Meters, P/N 210-106-00 or 210-180-00. This number only affects user supplied instruments connected to the analog out signal.

To Look at or Change the Scale

With the Indicator powered up and in the Run Mode, press both buttons at the same time to go to Setup. Scroll through the menu until the word SCALE is displayed, then press the Right button. The display should look like this:

Figure 3.9 Changing the Scale

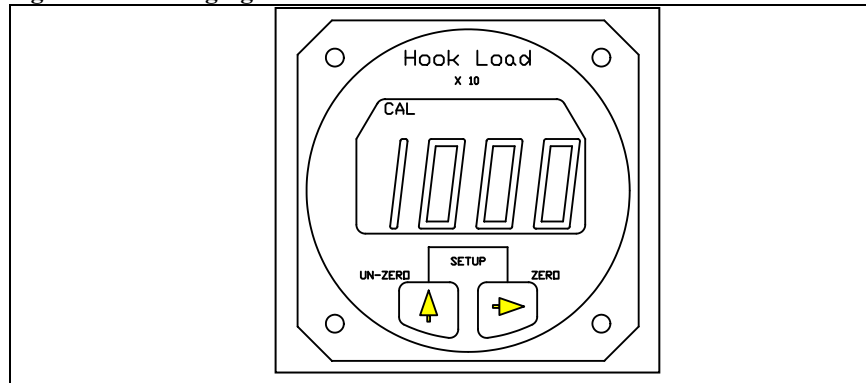

The Setup Mode, continued

To Look at or Change the Scale, continued

The CAL legend is turned on and the previously set Scale number is displayed. To return to Run without changing the Scale, press both the Right and Left button at the same time. To change the Scale number, use the Right button to select a digit to be changed, then use the Left button to scroll the blinking digit to the desired number. When the complete Scale number has been entered, press both the Right and Left button at the same time to return to Run.

Select KG or LB Units

The units routine sets the display to read in pounds (LB) or kilograms (KG).

To look at or change the Units

With the Indicator powered up and in the Run Mode, press both buttons at the same time to go to Setup. Scroll through the menu until the word LB or KG is displayed, then press the Right button. The display should look like this:

Figure 3.10 Changing the Units

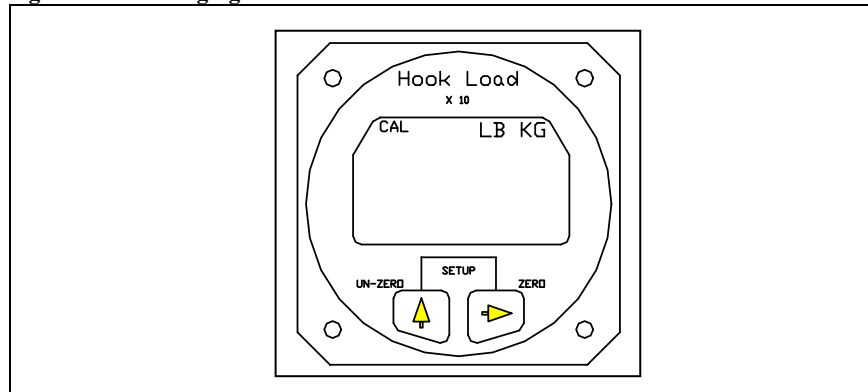

The CAL legend is turned on and the previously set unit is displayed. To return to Run without changing the units, press both the Right and Left button at the same time. To change the units press the Left button. When the selection has been made, press both the Right and Left button at the same time to return to Run.

NOTICE

The selected units are displayed when in the Run Mode.

The Setup Mode, continued

Indicator Version

The Version routine displays the Indicator's hardware and software revision levels. Version is set at the factory and cannot be changed.

Figure 3.11 Looking at Indicator Version

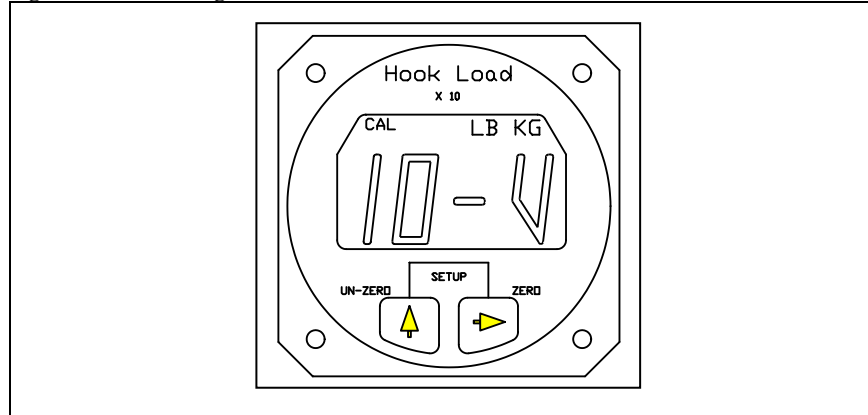

This page intentionally left blank.

Section 4

Operation Instructions

Operating Procedures

Prior to a flight involving external load operations perform the following.

1. Ensure that the Cargo Hook Kit has been properly installed and that the manual and electrical release cables do not limit the movement of the hook.
2. Be completely familiar with this Owners Manual, Cargo Hook Service Manual 122-005-00 and the ICA Maintenance Manual 123-014-01.
3. Activate the electrical system and press the Cargo Hook release button to ensure the cargo hook electrical release is operating correctly. The mechanism should operate smoothly and the Cargo Hook must release. Reset the hook by hand after the release. If the hook does not release or re-latch, do not use the unit until the difficulty is resolved.



The release solenoid is intended to be energized only intermittently. Depressing the electrical release button continuously in excess of 20 seconds will cause the release solenoid to overheat, possibly causing permanent damage.

4. Activate the manual release lever to test the cargo hook manual release mechanism. The mechanism should operate smoothly and the Cargo Hook must release. Reset the hook by hand after release. If the hook does not release or re-latch do not use the unit until the difficulty is resolved.
5. Swing the installed Cargo Hook and the suspension to ensure that the manual release cable assembly and the electrical release cable have enough slack to allow full swing of each component without straining or damaging the cables. The cables must not be the stops that prevent the Cargo Hook or the suspension from swinging freely in all directions.
6. Visually check for presence and security of fasteners, and condition of cables. Swing the Cargo Hook and the suspension in fore and aft and side to side directions to check for freedom of rotation at all joints.

Disconnecting Removable Provisions

For helicopter missions in which the cargo hook swing suspension system is not needed, its removable provisions may be removed per the following instructions.

1. Remove the removable section of the manual release cable by unclipping it from the bracket on the belly of the helicopter, disengaging the locking pin and unthreading the Adapter Fitting. Unclip the Release Cable Cap (see below) from the bracket and thread it over the open end of the fixed manual release cable assembly and clip it into the inboard spring clip on the bracket.

Figure 4.1 Manual Release Cable Disconnect

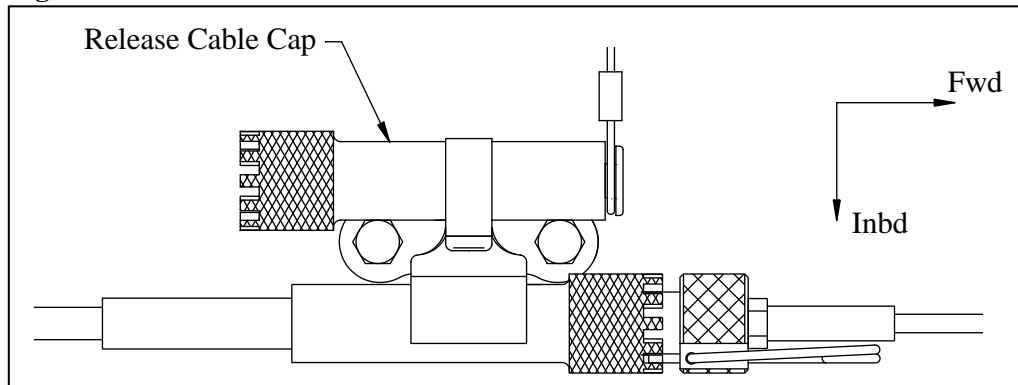

2. Remove the electrical cables and ground strap at the belly of the helicopter.
3. Remove the Swing Suspension by removing the safety pins and then the quick release pins that secure the cables to each of Shackle Assemblies.

Figure 4.2 Suspension Removal

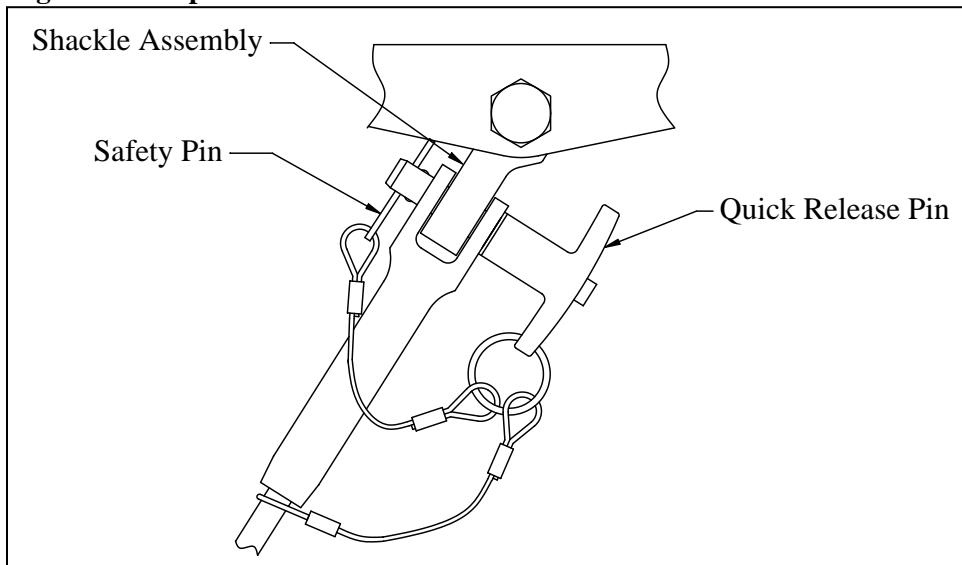

Cargo Hook Loading

The cargo hook can easily be loaded with one hand. A load is attached to the hook by pushing the ring upward against the upper portion of the load beam throat, as illustrated in Figure 4.3, until an internal latch engages the load beam and latches it in the closed position.

Figure 4.3 Cargo Hook Loading

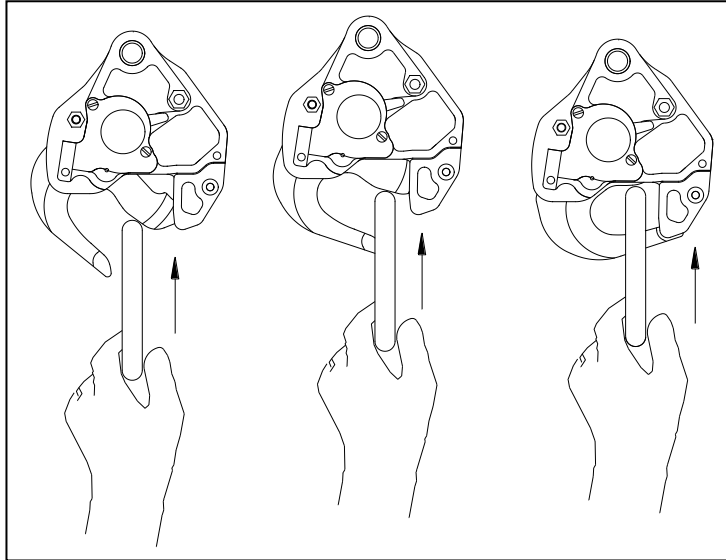

Cargo Hook Rigging

Extreme care must be exercised when rigging a load to the Cargo Hook. Steel load rings are recommended to provide consistent release performance and resistance to fouling. The following illustration shows the recommended rigging and configurations to avoid, but is not intended to represent all rigging possibilities.



It is the responsibility of the operator to assure the cargo hook will function properly with each rigging.



Multiple load rings, nylon type straps (or similar material) or rope must not be used directly on the cargo hook load beam. If nylon straps or rope must be used they should be first attached to a steel primary ring. Verify that the ring will freely slide off the load beam when it is opened. Only the primary ring should be in contact with the cargo hook load beam.

Cargo Hook Rigging, continued

Figure 4.4 Cargo Hook Load Rigging

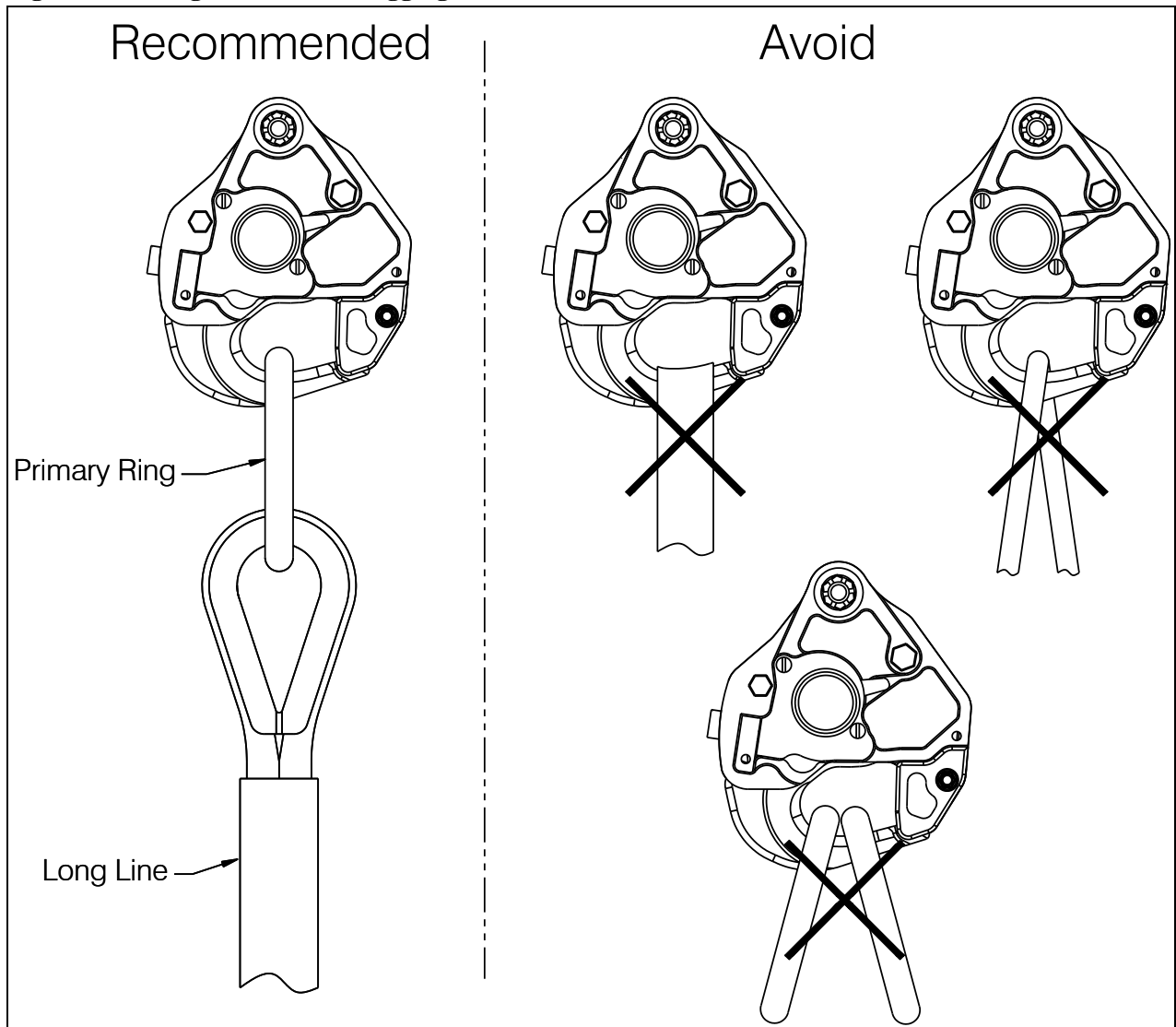

Section 5

Maintenance

Refer to the Instructions for Continued Airworthiness (ICA) manual 123-014-01 for maintenance of the cargo hook suspension system. For maintenance of the cargo hook refer to Cargo Hook Service Manual 122-005-00.

Instructions for Returning Equipment to the Factory

If an Onboard Systems product must be returned to the factory for any reason (including returns, service, repairs, overhaul, etc) obtain an RMA number before shipping your return.



An RMA number is required for all equipment returns.

- To obtain an RMA, please use one of the listed methods.
 - Contact Technical Support by phone or e-mail (Techhelp@OnboardSystems.com).
 - Generate an RMA number at our website: <http://www.onboardsystems.com/rma.php>
- After you have obtained the RMA number, please be sure to:
 - Package the component carefully to ensure safe transit.
 - Write the RMA number on the outside of the box or on the mailing label.
 - Include the RMA number and reason for the return on your purchase or work order.
 - Include your name, address, phone and fax number and email (as applicable).
 - Return the components freight, cartage, insurance and customs prepaid to:

Onboard Systems
13915 NW 3rd Court
Vancouver, Washington 98685
USA
Phone: 360-546-3072

This page intentionally left blank.

Section 6

System Part Numbers

200-286-01 AS350 Swing Retrofit Kit

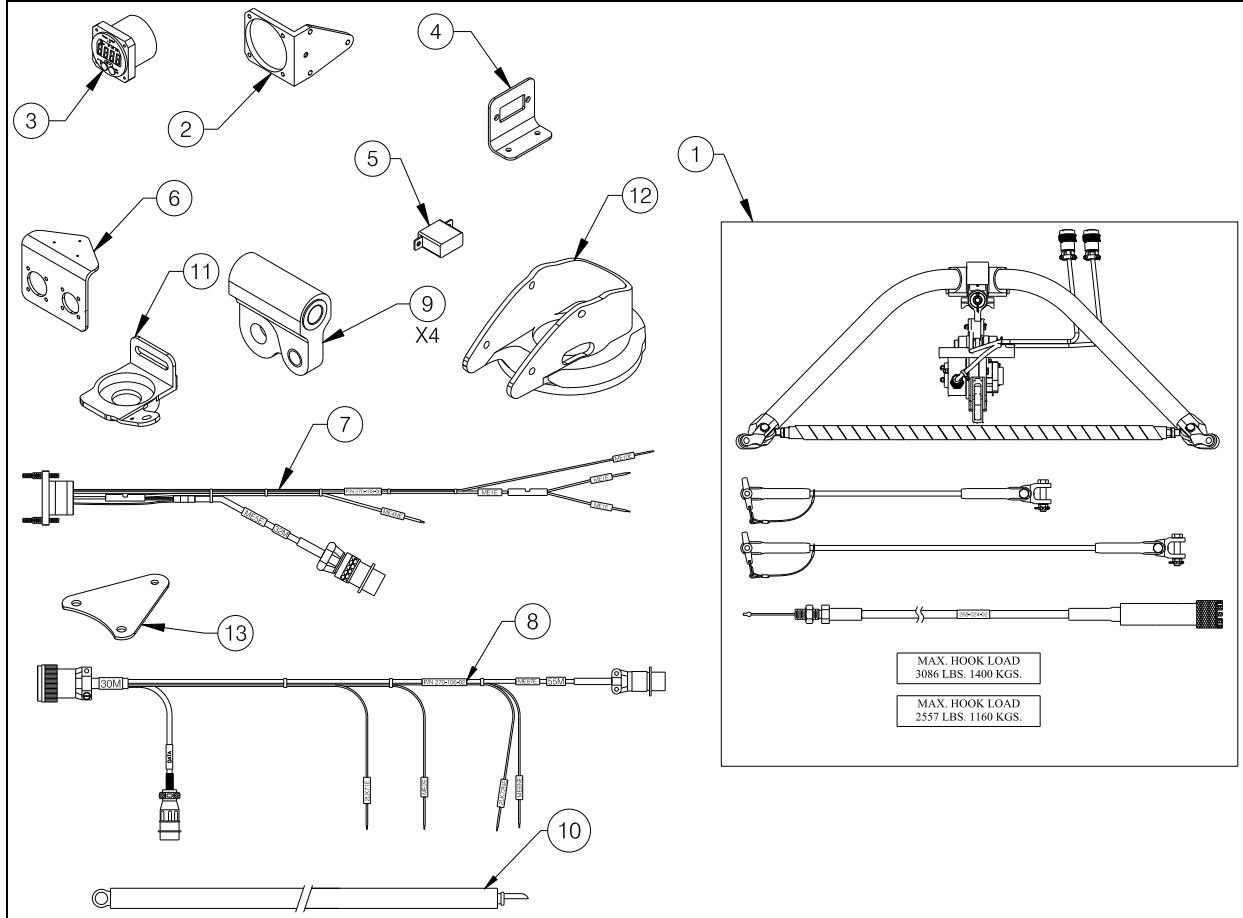

Item	Part Number	Description	Qty
1	210-201-01	AS 350 Swing Removable Provisions	1
2	290-772-00	Indicator Mount Bracket	1
3	210-095-00	C-39 Indicator Assembly	1
4	290-783-00	Relay Bracket	1
5	445-005-00	Relay	1
6	290-782-00	Connector Bracket	1
7	270-108-00	Electrical Release Internal Harness	1
8	270-106-02	Load Weigh Internal Harness	1
9	232-137-01	Shackle Assembly	4
10	270-125-00	Ground Strap, Fixed	1
11	290-888-00	Retainer	1
12	290-889-01	Guard	1
13	290-893-00	Bracket	1

System Part Numbers continued

210-201-01 AS 350 Swing Removable Provisions

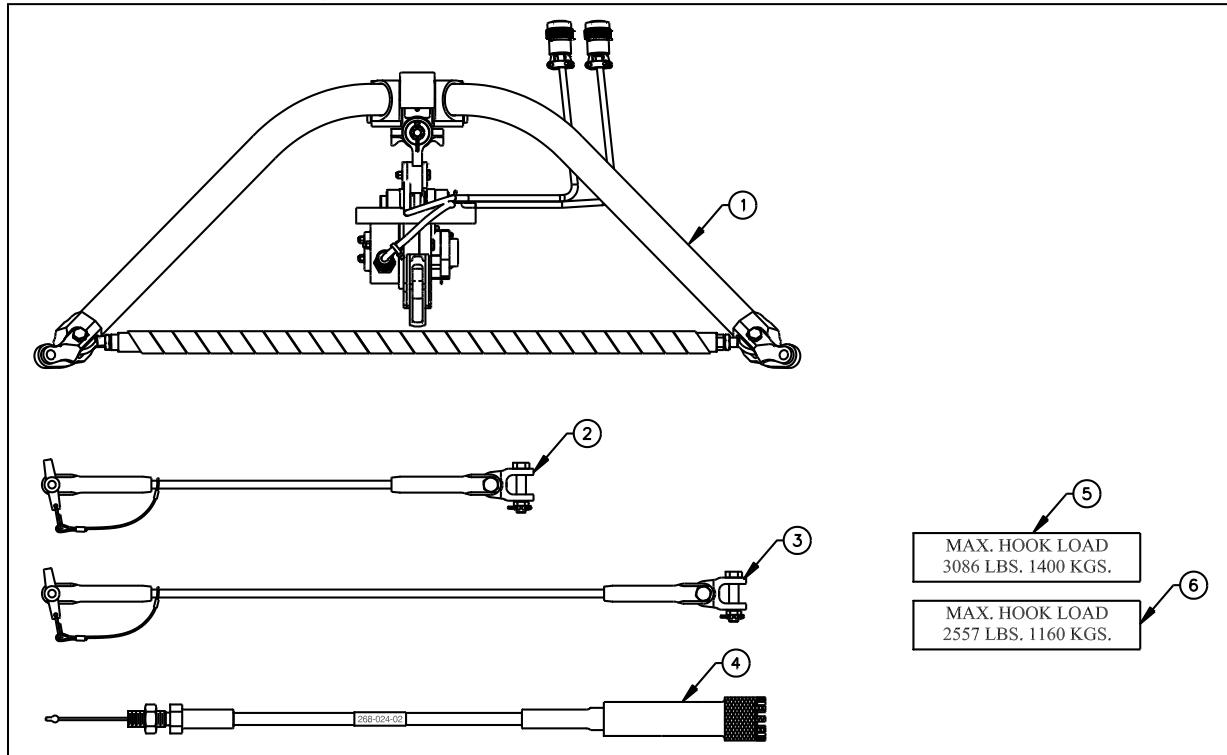

Item	Part Number	Description	Qty
1	232-145-01	Hook Frame Assembly	1
2	232-140-01	Forward Attach Cable Assembly	2
3	232-141-01	Aft Attach Cable Assembly	2
4	268-024-02	Manual Release Cable Assembly	1
5	215-166-00	Max Hook Load 3086 Decal	1
6	215-168-00	Max Hook Load 2557 Decal	1

System Part Numbers continued

232-137-01 Shackle Assembly

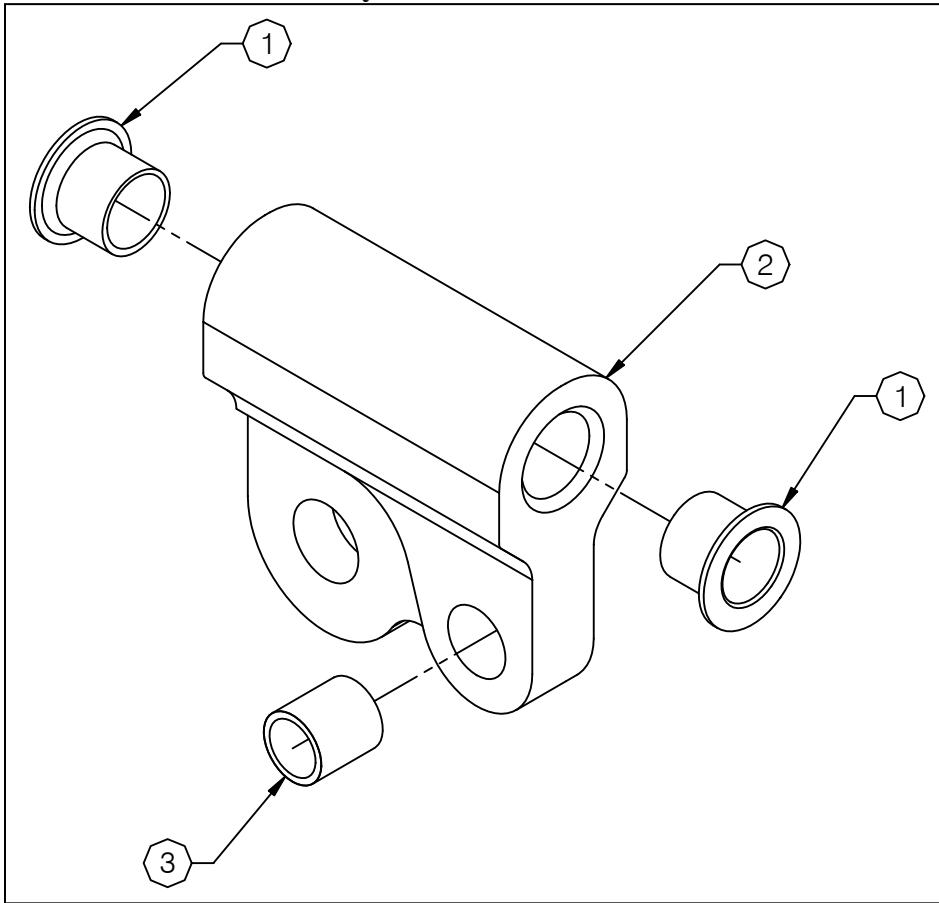

Item	Part Number	Description	Qty
1	517-047-00	Bushing	2
2	290-850-00	Airframe Attach Fitting	1
3	517-016-00	Bushing	1

System Part Numbers continued

232-140-01 Forward Attach Cable Assembly

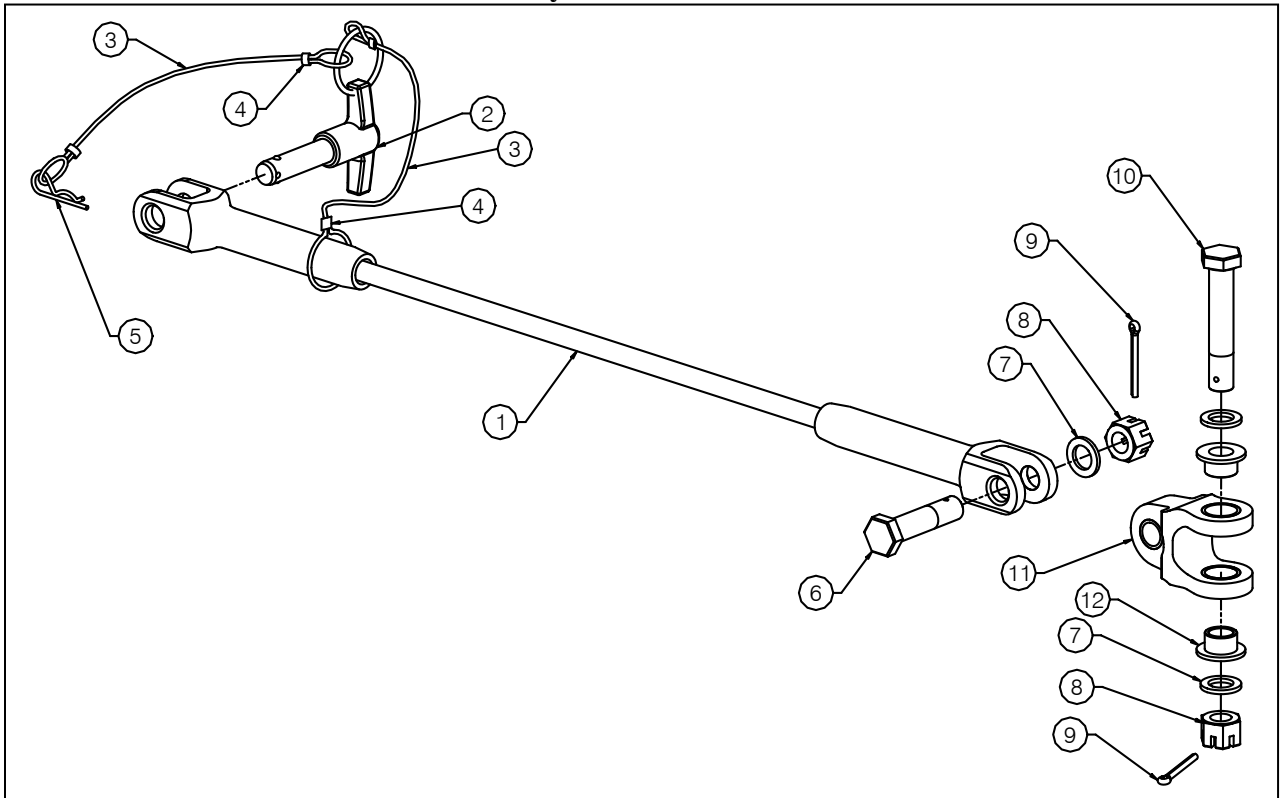

Item	Part Number	Description	Qty
1	232-177-00	Forward Attach Cable	1
2	290-851-00	Quick Release Pin	1
3	531-015-00	Lanyard Cable	2
4	531-016-00	Crimp Sleeve	2
5	510-464-00	Hitch Pin	1
6	510-438-00	Bolt	1
7	510-221-00	Washer	3
8	510-440-00	3/8" Castellated Nut	2
9	510-178-00	Cotter Pin	2
10	510-439-00	Bolt	1
11	232-142-00	Lower Attach Gimbal Assembly	1
12	290-749-00	Standoff Bushing	2

System Part Numbers continued

232-141-01 Aft Attach Cable Assembly

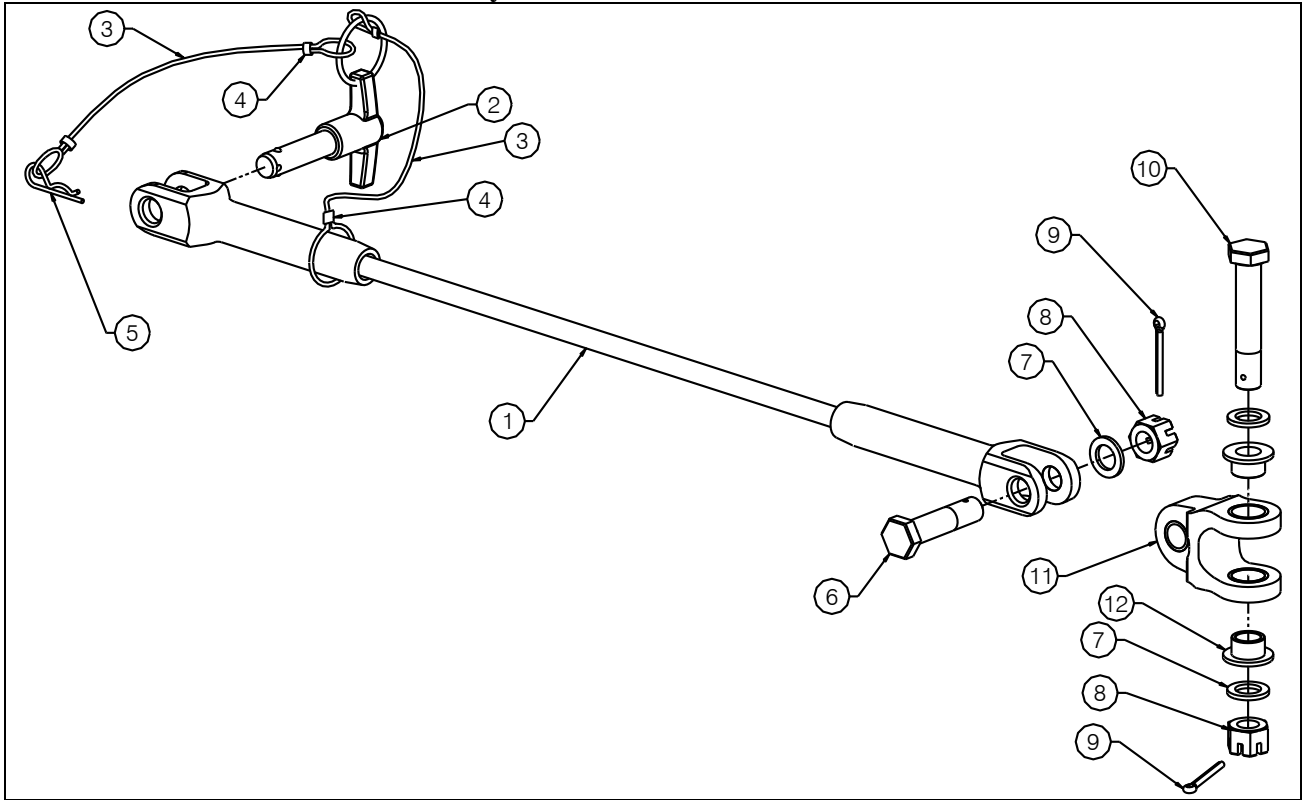

Item	Part Number	Description	Qty
1	232-178-00	Aft Attach Cable	1
2	290-851-00	Quick Release Pin	1
3	531-015-00	Lanyard Cable	2
4	531-016-00	Crimp Sleeve	2
5	510-464-00	Hitch Pin	1
6	510-438-00	Bolt	1
7	510-221-00	Washer	3
8	510-440-00	3/8" Castellated Nut	2
9	510-178-00	Cotter Pin	2
10	510-439-00	Bolt	1
11	232-142-00	Lower Attach Gimbal Assembly	1
12	290-749-00	Standoff Bushing	2

System Part Numbers continued

232-142-00 Lower Attach Cable Gimbal Assembly

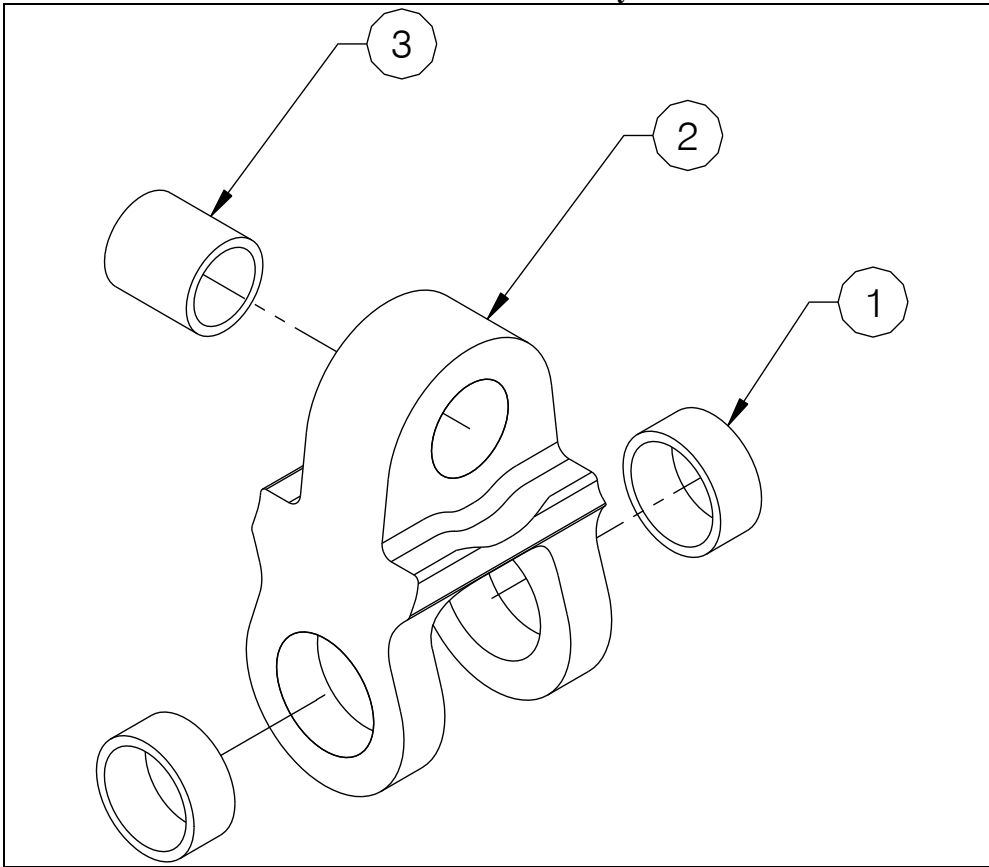

Item	Part Number	Description	Qty
1	517-048-00	Bushing	2
2	290-746-00	Lower Cable Gimbal	1
3	517-016-00	Bushing	1

System Part Numbers continued

232-143-01 Loadcell Gimbal Assembly

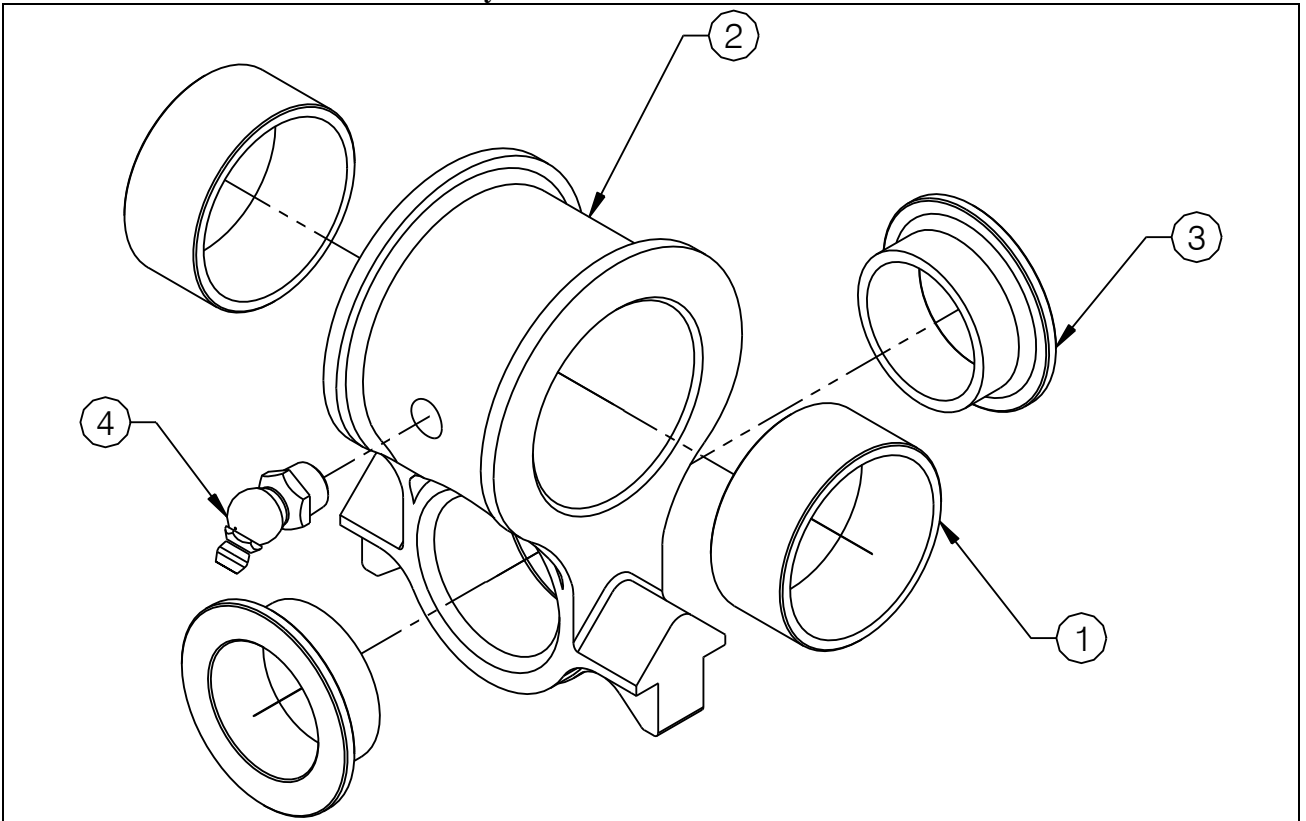

Item	Part Number	Description	Qty
1	517-056-00	Bushing Upper Hook Gimbal	2
2	290-841-00	Gimbal Link	1
3	517-046-00	Bushing Lower Hook Gimbal	2
4	518-003-00	Grease Fitting	1

System Part Numbers continued

232-145-01 Swing Hook Frame Assembly

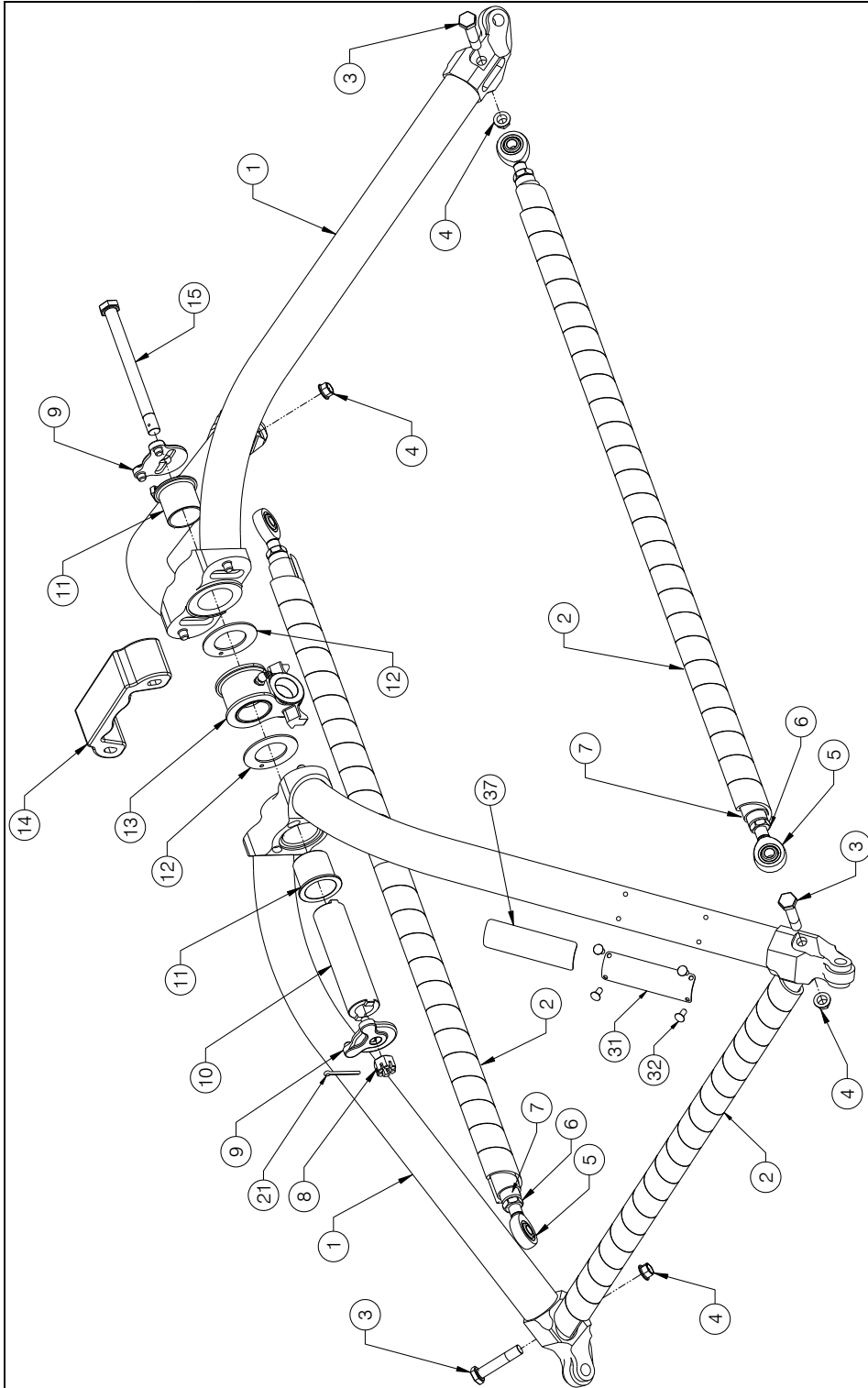

System Part Numbers continued

232-145-01 Swing Hook Frame Assembly continued

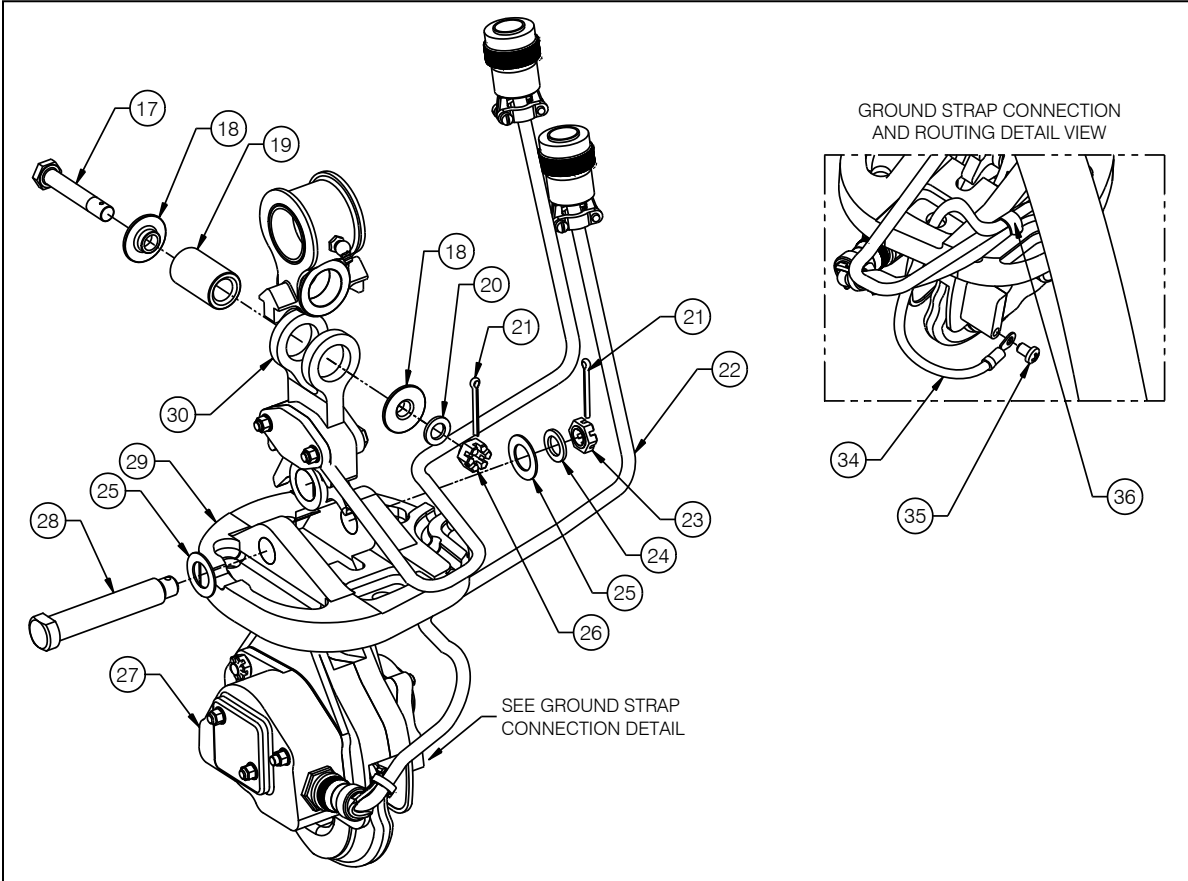

System Part Numbers continued

232-145-01 Swing Hook Frame Assembly continued



Item	Part No.	Description	Qty
1	235-117-00	Swing Frame Half	2
3	510-762-00	Bolt	4
4	510-104-00	Nut	4
5	517-055-00	Spherical Bearing	4
6	510-510-00	Jam Nut	4
7	235-116-00	Frame Strut	2
8	510-440-00	Nut, Castellated	1
9	290-843-00	Shaft Cap	2
10	290-842-00	Shaft – Pivot	1
11	517-057-00	Bearing	2
12	517-058-00	Bearing	2
13	232-143-01	Loadcell/Gimbal Assembly	1
14	290-862-00	Bumper	1
15	510-506-00	Bolt	1
17	510-443-00	Bolt	1
18	290-740-00	Shaft Retaining Bushing	2
19	290-739-00	Shaft – Gimbal	1
20	510-220-00	Washer	1
21	510-178-00	Cotter Pin	3
22	270-107-00	Lower Electrical Release Cable	1
23	510-170-00	Nut	1
24	510-174-00	Washer	1
25	510-183-00	Washer	1
26	510-320-00	Nut, Castellated	1
27	528-023-01	3,500lb Keeperless Cargo Hook	1
28	290-775-00	Long Hook Attach Bolt	1
29	290-774-00	Hook Bumper	1
30*	210-249-03	AS350 Swing Load Cell Assembly	1
31	590-008-00	Plastic Tubing Wrap	80''
32	215-183-00	Serial Number Plate	1
33	510-486-00	Rivet, 1/8''	4
34	270-126-00	Ground Strap	1
35	510-391-00	Screw	1
36	512-011-00	Ty-Wrap	2
37	215-271-00	Fuel Drain Warning Placard	1

* Supersedes 210-249-00, 210-199-01 and 210-199-00. These part numbers are interchangeable.

Section 7

Certification

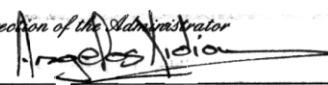
FAA STC

<small>United States of America</small> Department of Transportation—Federal Aviation Administration Supplemental Type Certificate	
<i>Number</i> SR01393SE	
<i>This certificate, issued to</i>	Onboard Systems 13915 NW 3RD COURT Vancouver, WA 98685
<i>certifies that the change in the type design for the following product with the limitations and conditions therefor as specified hereon meets the airworthiness requirements of Part 27 of the Federal Aviation Regulations.</i>	
<i>Original Product—Type Certificate Number:</i>	H9EU
<i>Make:</i>	Eurocopter
<i>Model:</i>	AS350B, AS350B1, AS350B2, AS350B3, AS350BA, and AS350D
<i>Description of the Type Design Change:</i> Fabrication of Onboard Systems Model 200-286-01 Cargo Hook Kit in accordance with FAA approved Onboard Systems Master Drawing List No. 155-093-00, Rev. 2, dated September 17, 2004, or later FAA approved revision; and <u>Installation</u> of this replacement Cargo Hook Kit in accordance with FAA approved Onboard Systems Owner's Manual No. 120-107-01, Rev. 0, dated September 16, 2004, or later FAA approved revisions. <u>Inspect and Maintain</u> Cargo Hook Kit in accordance with Section 5 of FAA approved Onboard Systems ICA Document 123-014-01, Rev. 0, dated September 16, 2004, Onboard Systems AS350 Swing Kit Owners Manual 120-107-01, Rev. 0, dated September 16, 2004, and Onboard Systems Cargo Hook Service Manual 122-005-00, dated September 19, 2002, or later FAA approved revision.	
<i>Limitations and Conditions:</i> Approval of this change in type design applies to only those Eurocopter model rotorcraft listed. This approval should not be extended to helicopters of these models on which other previously approved modifications are incorporated unless it is determined by the installer that the relationship between this change and any of those other previously approved modifications, including changes in type design, will introduce no adverse effect upon the airworthiness of that helicopter. Rotorcraft modified in accordance with this STC must be operated in accordance with an FAA approved copy of the Rotorcraft Flight Manual Supplement (RMFM), Onboard Systems Document No. 121-015-01, dated December 10, 2004, or later FAA approved revision. A copy of this Certificate and the FAA approved Rotorcraft Flight Manual Supplement must be maintained as part of the permanent records of the modified helicopter.	
If the holder agrees to permit another person to use this certificate to alter the product, the holder shall give the other person written evidence of that permission.	
<i>This certificate and the supporting data which is the basis for approval shall remain in effect until surrendered, suspended, revoked, or a termination date is otherwise established by the Administrator of the Federal Aviation Administration.</i>	
<i>Date of application:</i>	February 20, 2003
<i>Date of issuance:</i>	April 5, 2004
<i>Date reissued:</i>	
<i>Date amended:</i>	December 10, 2004
<i>By direction of the Administrator</i>  _____ (Signature)	
Acting Manager, Seattle Aircraft Certification Office _____ (Title)	
	
<small>Any alteration of this certificate is punishable by a fine of not exceeding \$1,000, or imprisonment not exceeding 3 years, or both.</small>	
<small>This certificate may be transferred in accordance with FAR 21.47.</small>	
<small>FAA FORM 8110-2(10-68)</small>	

Canadian Approval



Transport
Canada

Transports
Canada

Aviation

Aviation

Suite 620
800 Burrard Street
Vancouver, B.C.
V6Z 2J8

Your file Votre référence
130S-GA-04-28
Our file Notre référence
P-04-0212

May 27, 2004

Mark Hanson, Data Manager
Onboard Systems
13915 NW 3rd Court
Vancouver, WA 98685
USA

Dear Mr. Hanson

Subject: Acceptance of FAA STC SR01393SE

This is in response to the FAA Seattle ACO letter requesting Transport Canada approval of the subject STC.

In accordance with our current policy associated with the review of foreign STC's, some STCs applicable to certain categories of aircraft may be accepted solely on the basis of their foreign certification, and do not require the issue of a corresponding certificate by Transport Canada. The subject STC falls within these criteria.

This STC will be entered in the national index of STCs that have been reviewed and accepted by Transport Canada for installation on Canadian registered aeronautical products.

This letter confirms formal acceptance of the referenced STC by Transport Canada.

Yours truly,

Henry Wong
for
Regional Manager
Aircraft Certification

c.c. Mr. Jeffrey E. Duven, Manager, Seattle Aircraft Certification Office

Canada

1/1

EASA STC



European Aviation Safety Agency

SUPPLEMENTAL TYPE CERTIFICATE

10016870, REV. 1

This Supplemental Type Certificate is issued by EASA, acting in accordance with Regulation (EC) No. 216/2008 on behalf of the European Community, its Member States and of the European third countries that participate in the activities of EASA under Article 66 of that Regulation and in accordance with Commission Regulation (EC) No. 1702/2003 to

ONBOARD SYSTEMS INT.

13915 NW 3rd COURT
VANCOUVER WA 98685
USA

and certifies that the change in the type design for the product listed below with the limitations and conditions specified meets the applicable Type Certification Basis and environmental protection requirements when operated within the conditions and limitations specified below:

Original Product TC Number : EASA.R.008
TC Holder : EUROCOPTER
Model : AS350B, AS350BA, AS350B1
Model : AS350B2, AS350B3, AS350D
Original STC Number : FAA STC SR01393SE

Description of Design Change:

Onboard Systems cargo hook kits P/N 200-286-01 (with cargo hook P/N 528-023-01) and P/N 200-286-02 (with cargo hook P/N 528-029-00)
Revision 1 - introduces cargo hook kit P/N 200-286-02
This STC is the validation of FAA STC SR01393SE (issued on April 05, 2004 and last amended on June 29, 2010).

See Continuation Sheet(s)

For the European Aviation Safety Agency,

Date of issue: 04.02.2011

Massimo MAZZOLETTI
Certification Manager
Rotorcraft, Balloons, Airships

Note:
The following numbers are listed on the certificate:
EASA old Project Number: EASA.IM.R.S.01246, REV. 1

SUPPLEMENTAL TYPE CERTIFICATE - 10016870 REV. 1 - ONBOARD SYSTEMS INT.

EASA Form B1, Issue 4 - 24/09/2010

1/3

continued

EASA STC continued



European Aviation Safety Agency

EASA Certification Basis:

The Certification Basis for the original product and the following additional or alternative airworthiness requirements are applicable to this certificate/ approval.

Change under revision 1 complies with FAR Part 27, amends 27-1 through 27-39

The requirements for environmental protection and the associated certificated noise and/ or emissions levels of the original product are unchanged and remain applicable to this certificate/ approval.

Associated Technical Documentation:

Definition and installation:

Onboard Systems Master Drawing List No. 155-093-00, Rev. 8 dated November 16, 2010 and

for cargo hook kit P/N 200-286-01:

Onboard Systems Owner's Manual No. 120-107-01 Rev. 6 dated September 01, 2010

for cargo hook kit P/N 200-286-02:

Onboard Systems Owner's Manual No. 120-107-02 Rev. 1 dated September 01, 2010

Inspection and maintenance:

for cargo hook kit P/N 200-286-01:

Onboard Systems Instructions for Continued Airworthiness No. 123014-01, Rev. 5 dated August 24, 2010 and

Onboard Systems Cargo Hook Service Manual No. 122-005-00 Revision 19, dated October 5, 2010

for cargo hook kit P/N 200-286-02:

Onboard Systems Instructions for Continued Airworthiness No. 123014-02, Rev. 1 dated September 01, 2010 and

Onboard Systems Cargo Hook Service Manual No. 122-017-00 Revision 12, dated December 1, 2010

Operation:

for cargo hook kit P/N 200-286-01:

Onboard Systems RFMS No. 121-015-01, Rev. 0 dated December 10, 2004

for cargo hook kit P/N 200-286-02:

Onboard Systems RFMS No. 121-015-02, Rev. 1 dated December 03, 2010

or later revisions of the above listed documents approved by EASA in accordance with EASA ED Decision 2004/04/CF (or subsequent revisions of this decision)

Limitations:

None

See Continuation Sheet(s)

Note:

The following numbers are listed on the certificate:

EASA old Project Number: EASA.I.M.R.S.01246, REV. 1

SUPPLEMENTAL TYPE CERTIFICATE - 10016870, REV. 1 - ONBOARD SYSTEMS INT.

EASA Form 91, Issue 4 - 24/09/2010

2/3

continued

EASA STC continued



European Aviation Safety Agency

Conditions:

This STC is approved only for the product configuration as defined in the approved design data referred to in the paragraphs "Title/Description" and "Associated Technical Documentation". Compatibility with other aircraft/engine configurations shall be determined by the installer.

Prior to installation of this modification it must be determined that the interrelationship between this modification and any other previously installed modification and/ or repair will introduce no adverse effect upon the airworthiness of the product.

- end -

Note:

The following numbers are listed on the certificate:
EASA old Project Number: EASA.IM.R.S.01246, REV. 1

SUPPLEMENTAL TYPE CERTIFICATE - 10018870, REV. 1 - ONBOARD SYSTEMS INT.

EASA Form 91, Issue 4 - 24/09/2010

3/3