	Owner's Manual	Document Number 120-122-00	Revision 8
		Date 11/03/17	Page 1 of 44

Owner's Manual
3.5KK Talon LC Hydraulic
Cargo Hook Kits
with Load Weigh
 on the
BO-105S and BO-105LS A-3 Helicopters

Onboard Systems International
 13915 NW 3rd Court
 Vancouver, WA 98685 United States of America
 Cage Code: 1Y921
 Toll Free Phone: (800) 275-0883
 Phone: (360) 546-3072
 Fax: (360) 546-3073

Applicable Equipment Part Numbers

200-303-00
 200-303-10
 200-388-00
 200-388-10

[Please check our web site www.onboardsystems.com](http://www.onboardsystems.com)
for the latest revision of this manual.

	Owner's Manual	Document Number 120-122-00	Revision 8
		Date 11/03/17	Page 2 of 44

RECORD OF REVISIONS

Revision	Date	Page(s)	Reason for Revision
2	06/27/07	1-2, 2-5, 2-8, 2-9	Added spiral wrap (P/N 590-013-00) to BOM. Added instructions to page 2-5 to install spiral wrap over hydraulic hose. Clarified installation instructions and corrected part number for spiral wrap (page 2-8 and 2-9).
3	3/2/09	TOC & Section 2	Updated manual to reflect new load weigh harness configuration.
4	09/24/10	All	Updated bleed kit and associated instructions, updated safety label format throughout manual, updated appearance of load cell to reflect current configuration.
5	06/30/11	Section 2	Added kit P/N 200-388-00 and BO-105LS A-3 model.
6	01/25/12	1-4	Updated design load for kit P/N 200-388-00 to 3000 lbs.
7	06/08/16	All	Added kit P/Ns 200-303-10 and 200-388-10 which include Cargo Hook with Surefire. Removed C-39 load indicator instructions and replaced with reference to Owner's Manual 120-039-00.
8	11/03/17	All	Replaced fluid MIL-PRF-5606 with MIL-PRF-87257 and bleed kit 212-014-01 with 212-014-02. Updated layout and formatting.

Register Your Products for Automatic Notifications

Onboard Systems offers a free notification service via fax or email for product alerts and documentation updates. By registering your Onboard Systems products at our website, we will be able to contact you if a service bulletin is issued, or if the documentation is updated.

You can choose to receive notices on an immediate, weekly, or monthly schedule via fax, email or both methods. There is no charge for this service. Please visit our website at www.onboardsystems.com/notify.php to get started.

	Owner's Manual	Document Number 120-122-00	Revision 8
		Date 11/03/17	Page 3 of 44

CONTENTS

1.0	Introduction	4
1.1	Scope	4
1.2	Safety labels	4
2.0	Referenced Documents.....	5
3.0	System Overview.....	5
3.1	System Description	5
3.2	Surefire Release	6
3.3	Specifications.....	8
3.4	Bill of Materials.....	8
4.0	Installation	10
4.1	Master Cylinder Assembly Installation.....	11
4.2	Cargo Hook/Load Cell Installation	17
4.3	Load Weigh System Installation	21
4.3.1	Internal Harness Installation	21
4.3.2	Indicator Internal Back Light	23
4.3.3	Indicator Hook-Open Warning	24
4.3.4	Remote Analog Meter.....	24
4.3.5	Electrical Connections	25
4.4	Filling Hydraulic Release System.....	25
4.5	Installation Check-out.....	31
4.6	Component Weights	32
4.7	Paper Work.....	33
5.0	Operation Instructions	33
5.1	Operating Procedures	33
5.2	Cargo Hook Loading	36
5.3	Cargo Hook Rigging.....	36
6.0	Maintenance.....	38
6.1	Instructions for Returning Equipment to the Factory.....	38
7.0	Certification	39
7.1	STC	39
7.2	Transport Canada Approval	40
7.3	ANAC Approval.....	41
7.4	EASA STC	43

	Owner's Manual	Document Number 120-122-00	Revision 8
		Date 11/03/17	Page 4 of 44

1.0 Introduction

1.1 Scope

This owner's manual contains instructions for installation, operation, and maintenance of a Cargo Hook Kit with Load Weigh on BO-105S and BO-106LS A-3 helicopter.

1.2 Safety labels

The following definitions apply to safety labels used in this manual.



Indicates a hazardous situation which, if not avoided, will result in death or serious injury.



Indicates a hazardous situation which, if not avoided, could result in death or serious injury.



Indicates a hazardous situation which, if not avoided, could result in minor or moderate injury.



Draws the reader's attention to important or unusual information not directly related to safety.



Used to address practices not related to personal injury.

	Owner's Manual	Document Number 120-122-00	Revision 8
		Date 11/03/17	Page 5 of 44

2.0 Referenced Documents

- 120-039-00 Owner's Manual, C-39 Indicator
- 121-029-00 Rotorcraft Flight Manual Supplement
- 122-015-00 Component Maintenance Manual, Cargo Hook
- 123-022-00 ICA

3.0 System Overview

3.1 System Description

P/N 200-303-00 and 200-303-10 Cargo Hook Kits are approved for installation on the BO-105S model helicopter equipped with a suspension system installed per American Eurocopter STC SH286NE and the P/N 200-388-00 and 200-388-10 Cargo Hook Kits are approved for installation on a BO-105S or BO-105LS model equipped with a suspension P/N 117-80127 suspension (manufacturer of this suspension is Siren). These kits replace the cargo hook, an adapter link assembly, the manual release cable and an external electrical release wire harness on the existing cable type suspension system. They utilize the existing cable suspension and internal electrical wiring. These kits include a load weighing system which is comprised of a load indicator in the cockpit, the load cell above the cargo hook, and the interconnecting wire harness. The load cell replaces the adapter link assembly.

Kit P/Ns 200-303-00 and 200-303-10 are identical to P/Ns 200-388-00 and 200-388-10 respectively except for the adapter link assembly. The adapter link assembly serves to connect the cargo hook to the cable suspension shackles and is narrower in kit P/Ns 200-388-00 and 200-388-10 to accommodate the shackles on the P/N 117-80127 suspension.

Kit P/Ns 200-303-10 and 200-388-10 include a Cargo Hook with Surefire release as part of the electrical release system. Surefire release is a safety enhancement to protect against inadvertent load release due to accidental contact with the release switch or mistaken actuation of the release switch when another is intended.

The primary elements of the Cargo Hook are the load beam, the internal mechanism, and a DC solenoid. The load beam supports the load and is latched through the internal mechanism. The DC solenoid and an external hydraulic release system provide the means for unlatching the load beam.

The load is attached to the load beam by passing the cargo sling ring into the throat of the load beam and pushing the ring against the upper portion of the load beam throat, which will initiate the hook to close. In the closed position, a latch engages the load beam and latches it in this position.

	Owner's Manual	Document Number 120-122-00	Revision 8
		Date 11/03/17	Page 6 of 44

To release the load, the latch is disengaged from the load beam. With the latch disengaged, the weight of the load causes the load beam to swing to its open position, and the cargo sling slides off the load beam. The load beam then remains in the open position awaiting the next load.

A load release can be initiated by three different methods. Normal release is achieved by pilot actuation of the push-button release switch in the cockpit. When the switch is pressed, it energizes the DC solenoid in the Cargo Hook, and the solenoid opens the latch in the internal mechanism. In an emergency, release can be achieved by operating a hydraulic release lever. The hydraulic release lever operates the internal mechanism of the Cargo Hook to unlatch the load beam. The load can also be released by the actuation of a lever located on the side of the Cargo Hook.

3.2 Surefire Release

The optional cargo hook with Surefire includes a short time delay circuit built into the cargo hook's electrical release system (cargo hook P/N 528-028-02). This feature is a safety enhancement to protect against inadvertent load release due to accidental contact with the release switch or mistaken actuation of the cargo hook switch when another is intended. The time delay feature requires that the release switch be depressed and held for more than a 1/2 second to open the cargo hook. Surefire makes the electrical release a more deliberate pilot command. If the cargo hook must be released immediately, use the mechanical backup release.

	Owner's Manual	Document Number 120-122-00	Revision 8
		Date 11/03/17	Page 7 of 44

In addition to its P/N, a cargo hook with Surefire can be identified by a gold color solenoid housing (see Figure 3.1). Also a placard on the underside of the solenoid housing indicates that the electrical release is delayed by ½ second.

NOTICE

The 528-028-02 cargo hook includes an electronic delay of approximately ½ second. It is necessary to press and hold the cargo hook release button.

CAUTION

If a Surefire-equipped cargo hook must be released immediately without any delay (such as the case of engine failure or snagged load), use the mechanical backup release.

In addition to the delay feature the circuit includes on-off cycling to limit the duty-cycle on the solenoid. If the release switch is held down, the solenoid will cycle on and off repeatedly in a “machine gun” fashion.

Figure 3.1 Surefire Configuration Identification

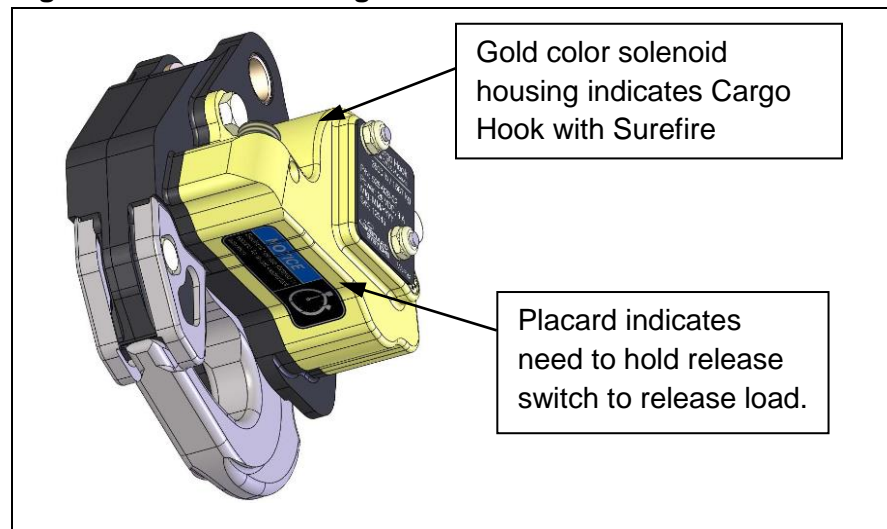

	Owner's Manual	Document Number 120-122-00	Revision 8
		Date 11/03/17	Page 8 of 44

3.3 Specifications

Table 3.1 System Specifications

Design load (P/N 200-303-00, -10)	2645 lb. (1200 kg)
Design load (P/N 200-388-00, -10)	3000 lb. (1360 kg)
Design ultimate strength (P/N 200-303-00, -10)	9920 lb. (4500 kg)
Design ultimate strength (P/N 200-388-00, -10)	11250 lb. (5103 kg)
Unit weight (all kits)	8.3 lbs (3.8 kg)

Table 3.2 P/N 528-028-00, -02 Cargo Hook Specifications

Design load	3,500 lbs. (1,587 kgs.)
Design ultimate strength	13,125 lbs. (5,952 kgs.)
Electrical release capacity	8,750 lbs. (3,968 kgs.)
Mechanical release capacity	8,750 lbs. (3,968 kgs.)
Electrical requirements	22-32 VDC 6.9 – 10 amps
Minimum release load	0 pounds
Unit weight	3.0 pounds (1.35 kg.)
Mating electrical connector	PC04A8-2P



Load capacities given are for the equipment described only. Loading limits for the helicopter still apply. Consult the flight manual.

3.4 Bill of Materials

The following items are included with the Cargo Hook Kits, if shortages are found contact the company from whom the system was purchased. The internal helicopter wiring and the cable suspension system are required to complete the installation.



	Owner's Manual	Document Number 120-122-00	Revision 8
		Date 11/03/17	Page 9 of 44

Table 3.3 Bill of Materials

Part No.	Description	Quantity		Quantity	
		200-303-00	200-303-10	200-388-00	200-388-10
232-757-01*	Cargo Hook/Load Cell Assembly	1	-	-	-
232-757-11	Cargo Hook/Load Cell Assembly	-	1	-	-
232-757-03**	Cargo Hook/Load Cell Assembly	-	-	1	-
232-757-13	Cargo Hook/Load Cell Assembly	-	-	-	1
232-208-01	Master Cylinder Assy with Plumbing	1	1	1	1
232-218-00	Hook Retainer Sling Assembly	1	1	1	1
235-128-00	Disconnect Bracket	1	1	1	1
270-048-04	Load Weigh Internal Harness	1	1	1	1
210-095-00	C-39 Indicator	1	1	1	1
512-010-00	Cushioned Loop Clamp	2	2	2	2
512-005-00	Cushioned Loop Clamp	4	4	4	4
510-102-00	Nut, 10-32	7	7	7	7
510-042-00	Washer, #10	7	7	7	7
510-391-00	Screw	7	7	7	7
512-021-00	Cushioned Loop Clamp	1	1	1	1
512-028-00	90 Deg. Angle Bracket	3	3	3	3
512-029-00	Ty-wrap	1	1	1	1
215-169-00	Indicator Light Placard	1	1	1	1
512-027-00	Cushioned Loop Clamp	4	4	4	4
512-001-00	Tie-wrap	10	10	10	10
215-010-00	Load Weigh Placard	2	2	2	2
215-012-00	Load Weigh Placard	1	1	1	1
215-343-00	Cockpit Decal	-	1	-	1
400-048-00	Power Switch	1	1	1	1
510-028-00	#4-40 Screw	4	4	4	4
510-029-00	Nut	4	4	4	4
510-062-00	Washer	8	8	8	8
590-013-00	Spiral Wrap	6 ft	6 ft	6 ft	6 ft
120-039-00	Owner's Manual, C-39 Indicator	1	1	1	1
120-122-00	Owner's Manual	1	1	1	1
121-029-00	RFMS	1	1	1	1
123-022-00	ICA (maintenance manual)	1	1	1	1

*Same as and replaces P/N 232-214-00.

**Same as and replaces P/N 232-504-00.

	Owner's Manual	Document Number 120-122-00	Revision 8
		Date 11/03/17	Page 10 of 44

4.0 Installation

These procedures are provided for the benefit of experienced aircraft maintenance facilities capable of carrying out the procedures. They must not be attempted by those lacking the necessary expertise.

Remove lower belly panels as necessary to access the areas in which the hose is to be routed. If the helicopter currently has an existing cargo hook suspension kit installed remove the following.*

- Cargo hook and its associated mounting brackets from the suspension.
- External wire harness.
- The entire mechanical release cable from the hook and up to and including the T-handle in the cockpit.

* The cargo hook kits use the helicopter's existing internal electrical wiring and cable suspension.

Retain the hardware used to fasten the cargo hook mounting brackets to the suspension shackles and the hardware to fasten the adel clamps to the suspension cables.

Plug the hole in the floor through which the T-handle was installed. This hole will not be used.

4.1 Master Cylinder Assembly Installation

The hydraulic release system is supplied dry. It is recommended that the system be filled and bled on the bench before installing on the helicopter. Refer to section 4.4 for filling and bleeding instructions.

The Master Cylinder Assembly (P/N 232-208-01) installation consists of installing the master cylinder on the collective in the cockpit, and routing the attached hose to a bracket to be installed near the right forward suspension cable.

Observe the following precautions (see Figure 4.1) when routing the hydraulic hose.

- Use care to avoid kinking the hose.
- Recommended minimum hose bend radii is 1 inch. Avoid abrupt change in direction of the hose just outside the end fittings. Provide smooth transitions where possible.
- Verify that the hose routing is clear of and cannot be deflected into chafe points.

Figure 4.1 General Hose Routing Practices

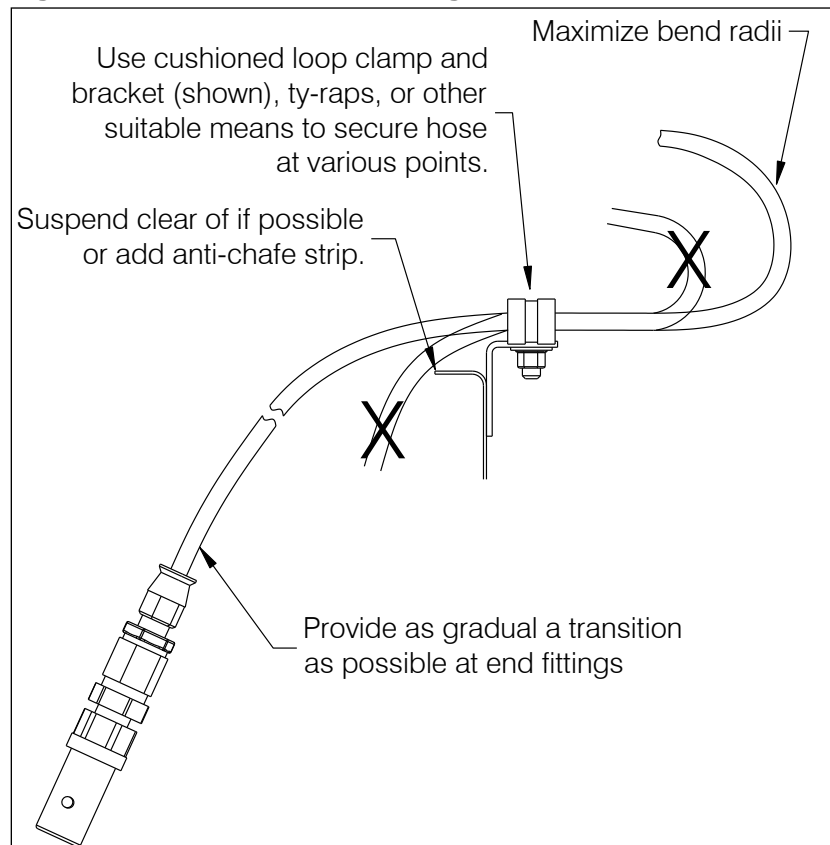

Install the Master Cylinder with Plumbing per the following:

- Mount the Master Cylinder Assembly (P/N 232-208-01) to the collective with the Clamp Half (P/N 290-912-00) and two screws (P/N 510-390-00) (provided pre-assembled on the assembly), in the location illustrated below.

Figure 4.2 Release Lever Installation

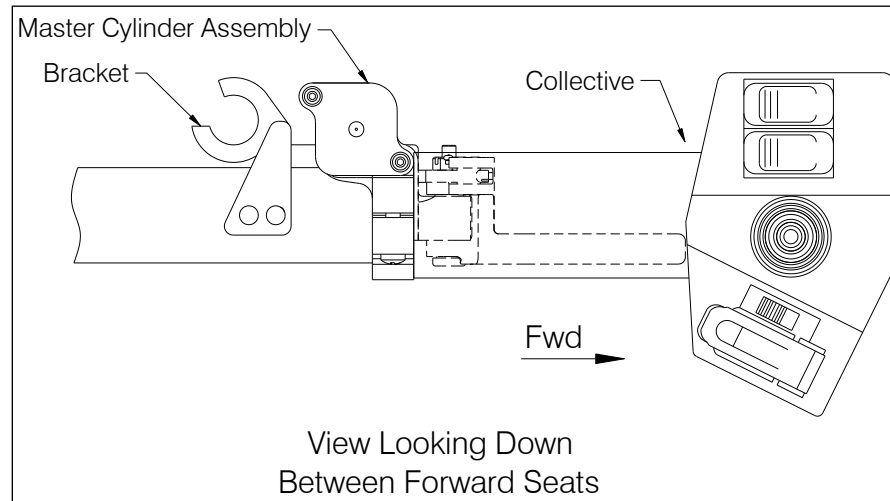

- Remove the bellows at the base of the collective and route the hose down through the hole in the cabin floor through which the collective electrical wire harness is routed.

	Owner's Manual	Document Number 120-122-00	Revision 8
		Date 11/03/17	Page 13 of 44

- Secure hose with loop clamps (P/N's 512-010-00 and 512-021-00) as shown below, using hardware provided. Add sufficient loop (as shown below) between the loop clamps to account for full movement of collective.

Figure 4.3 Hydraulic Hose Routing

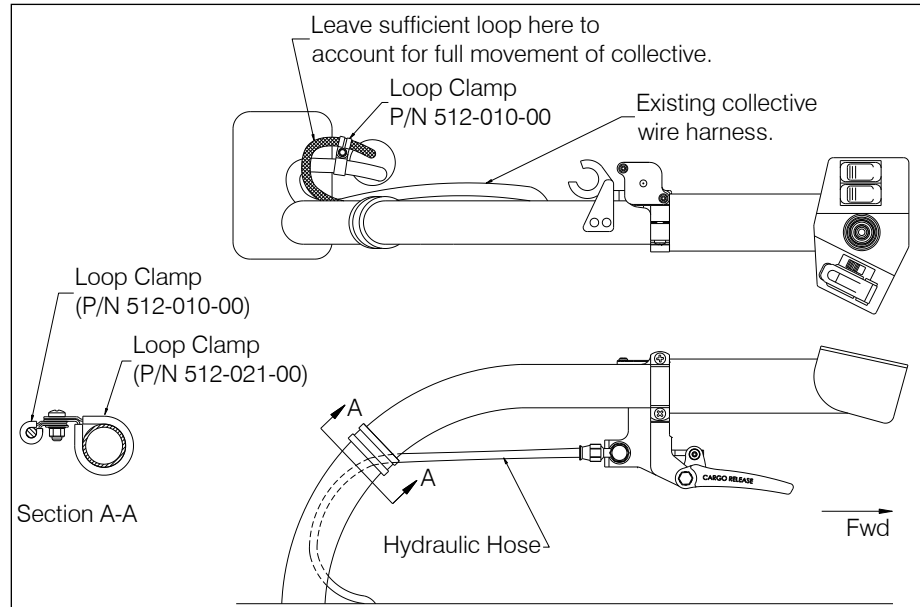

Underneath the cabin floor the hose is routed aft and outboard to the right forward suspension cable attach point. Figure 4.4 is an overview of the routing.

Figure 4.4 Fixed Hydraulic Release System Installation Overview

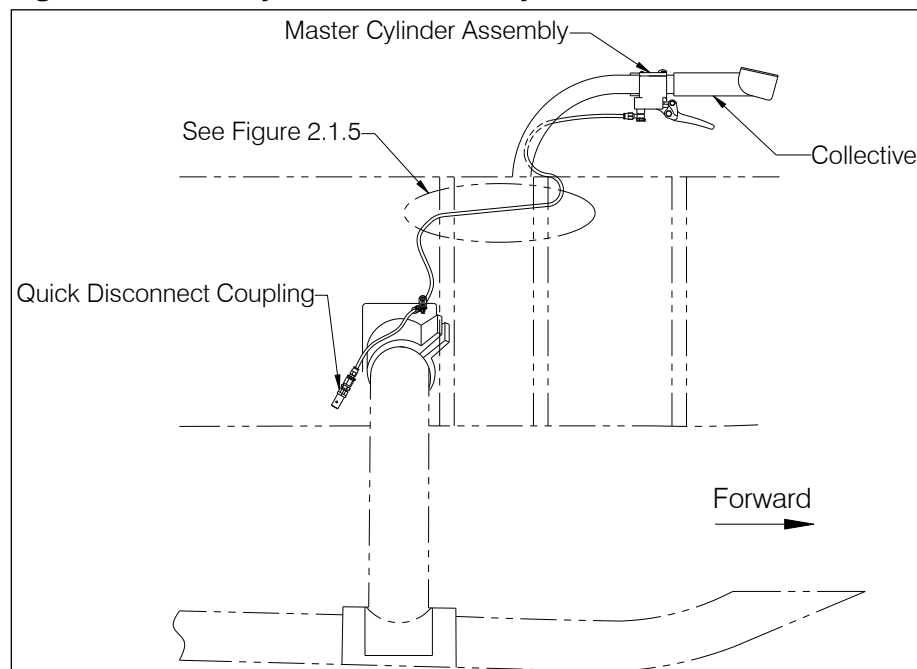

	Owner's Manual	Document Number 120-122-00	Revision 8
		Date 11/03/17	Page 14 of 44

- Aft of the hole in the cabin floor route the hose through existing holes in the airframe as shown below and then secure per Figure 4.6.

Figure 4.5 Hose Routing Under Cabin Floor

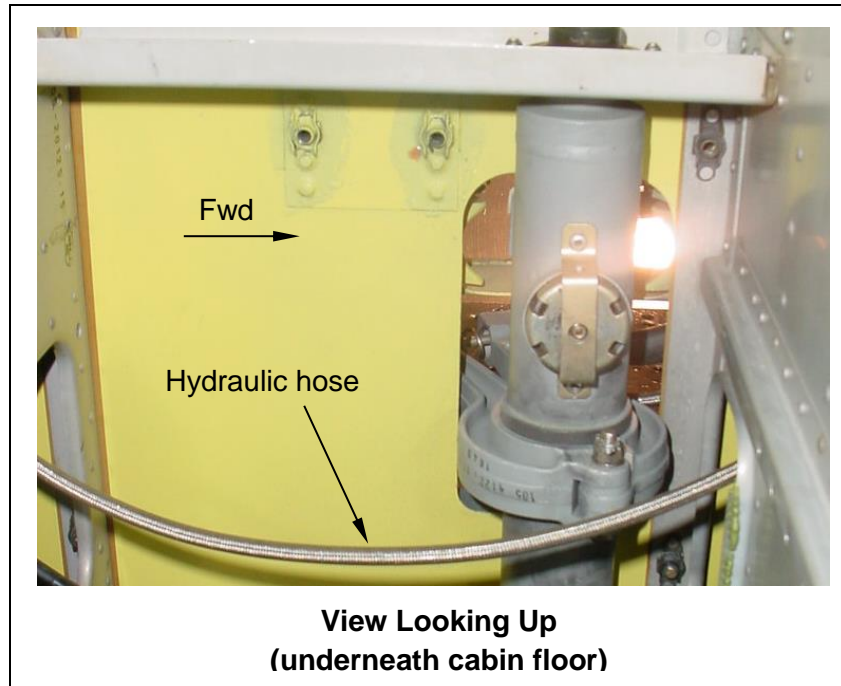

Aft of the 2nd frame the hose is routed over the skid gear tube. Before securing the hose with the cushioned loop clamps as shown below, layout the section of hose that will be above the skid gear tube and install approximately 3 feet (1 m) of the supplied spiral wrap (P/N 590-013-00) over this section. This will protect against rubbing/chafing in this area.

At the two frames through which the hose passes through, secure the hose using a loop clamp (P/N 512-010-00) and bracket (P/N 512-028-00) as described below.

- Drill a .196" (5 mm) diameter hole in the frames (maintain 2D edge distances) to locate the brackets as shown below and secure the brackets with screws (P/N 510-493-00), washers (P/N 510-042-00), and nuts (P/N 510-102-00).
- Install the loop clamps over the hose and attach the loop clamps to the bracket with screws (P/N 510-493-00), washers (P/N 510-042-00), and nuts (P/N 510-102-00).

Figure 4.6 Hose Attachment Points

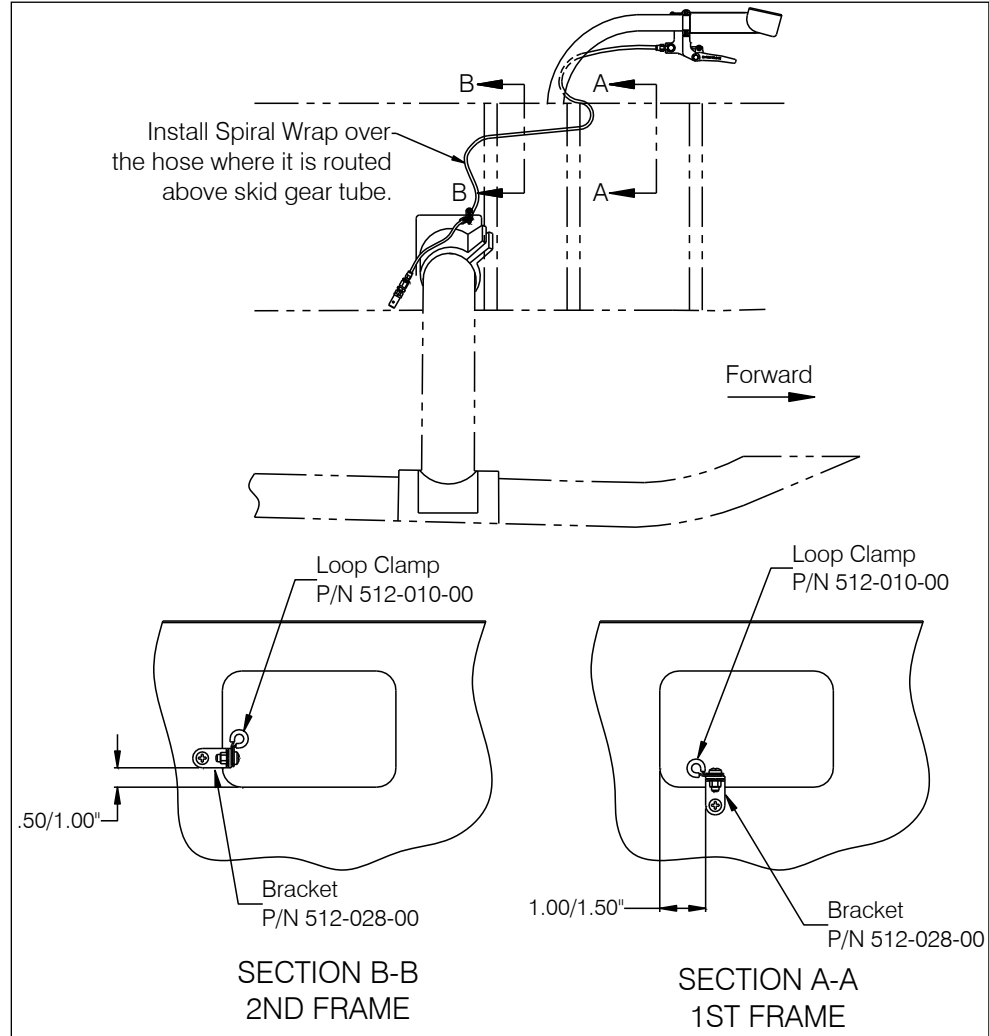

- At the right forward suspension cable attachment clevis, remove the existing manual release cable support bracket and loop clamp and replace with the supplied Quick Disconnect Bracket P/N 235-128-00.

Figure 4.7 Disconnect Bracket Installation

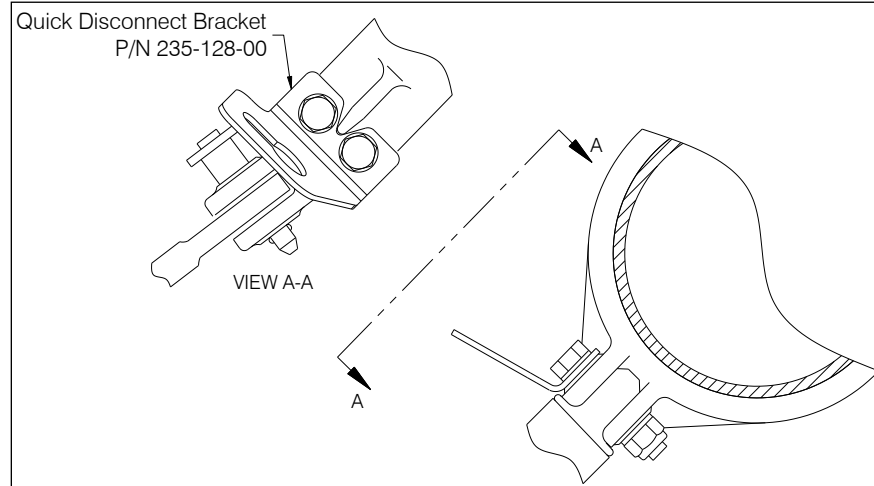

- Insert quick disconnect fitting through keyhole slot in bracket and slide inboard capturing the bracket flange between the nut and the end of the fitting. Tighten nut.

Figure 4.8 Disconnect Installation

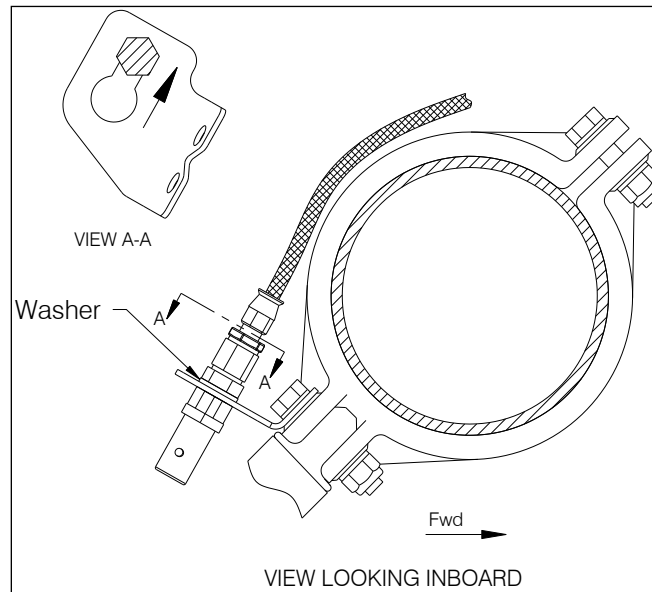

Secure the hose above the landing gear tube (at location shown below).

- Drill .196" (5 mm) diameter hole in helicopter skin and attach the bracket (P/N 512-028-00) with screw (P/N 510-493-00), washer (P/N 510-042-00), and nut (P/N 510-102-00).
- Place a loop clamp (P/N 512-010-00) over the hose and secure the loop clamp to the bracket with screw (P/N 510-493-00), washer (P/N 510-042-00), and nut (P/N 510-102-00).

Figure 4.9 Hose Tie-Off Point

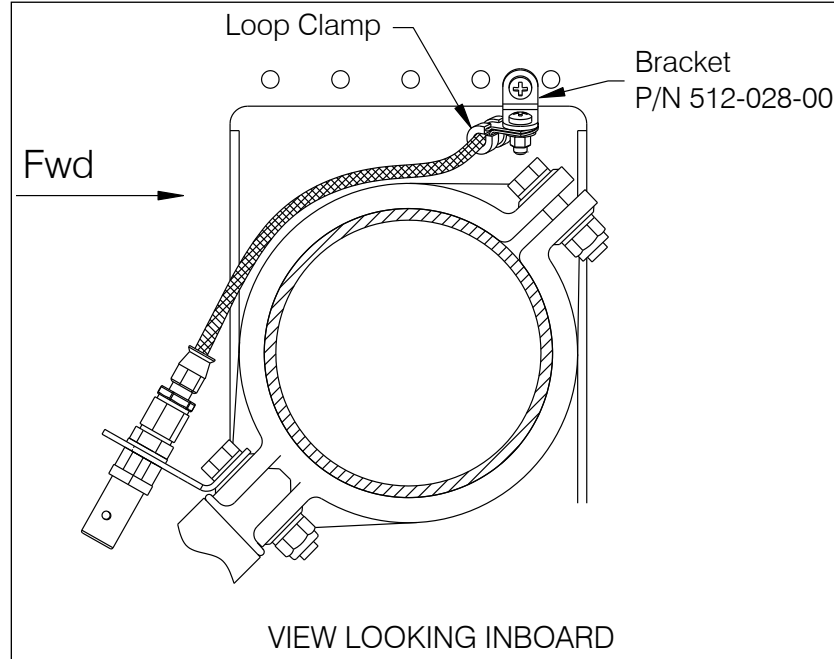

4.2 Cargo Hook/Load Cell Installation

1. Attach the Cargo Hook/Load Cell Assembly to the shackles using the hardware removed previously. Orient the assembly such that the load beam is pointing forward (as shown below).

Figure 4.10 Cargo Hook and Load Cell Assembly Installation

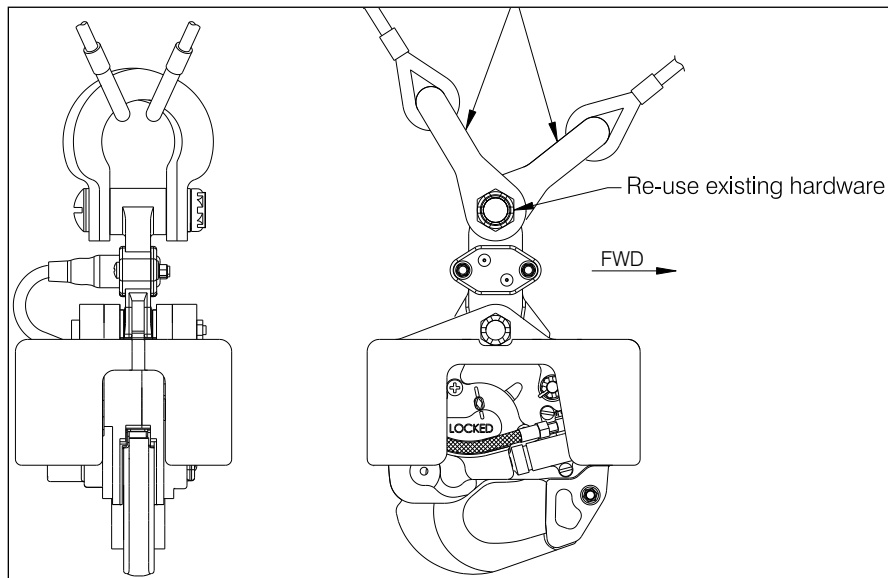

	Owner's Manual	Document Number 120-122-00	Revision 8
		Date 11/03/17	Page 18 of 44

2. Route the hydraulic hose up the right forward suspension cable and secure it in four places, uniformly spaced, to the suspension cable using the P/N 512-024-00 loop clamps attached to the suspension cable loop clamps as shown in Figure 4.11.
3. Route the electrical release harness and the load cell harness up the left forward suspension cable and secure it in four places, uniformly spaced, to the suspension cable using the P/N 512-027-00 loop clamps attached to the suspension cable loop clamps as shown in Figure 4.11.
4. To protect the electrical harness when the cargo hook is in the stowed position, cut and install a 2 to 3 foot length of the supplied Spiral Wrap (P/N 590-013-00) over it at location shown in Figure 4.11. Position of the wrap is to be checked at installation check-out as described in section 4.5.



Allow sufficient slack in the hose and electrical release harness between the last tie off point at the cargo hook bumper and the lowest loop clamp to account for pivoting and movement of the cargo hook.

Figure 4.11 Hose and Harness Routing at Suspension Cables

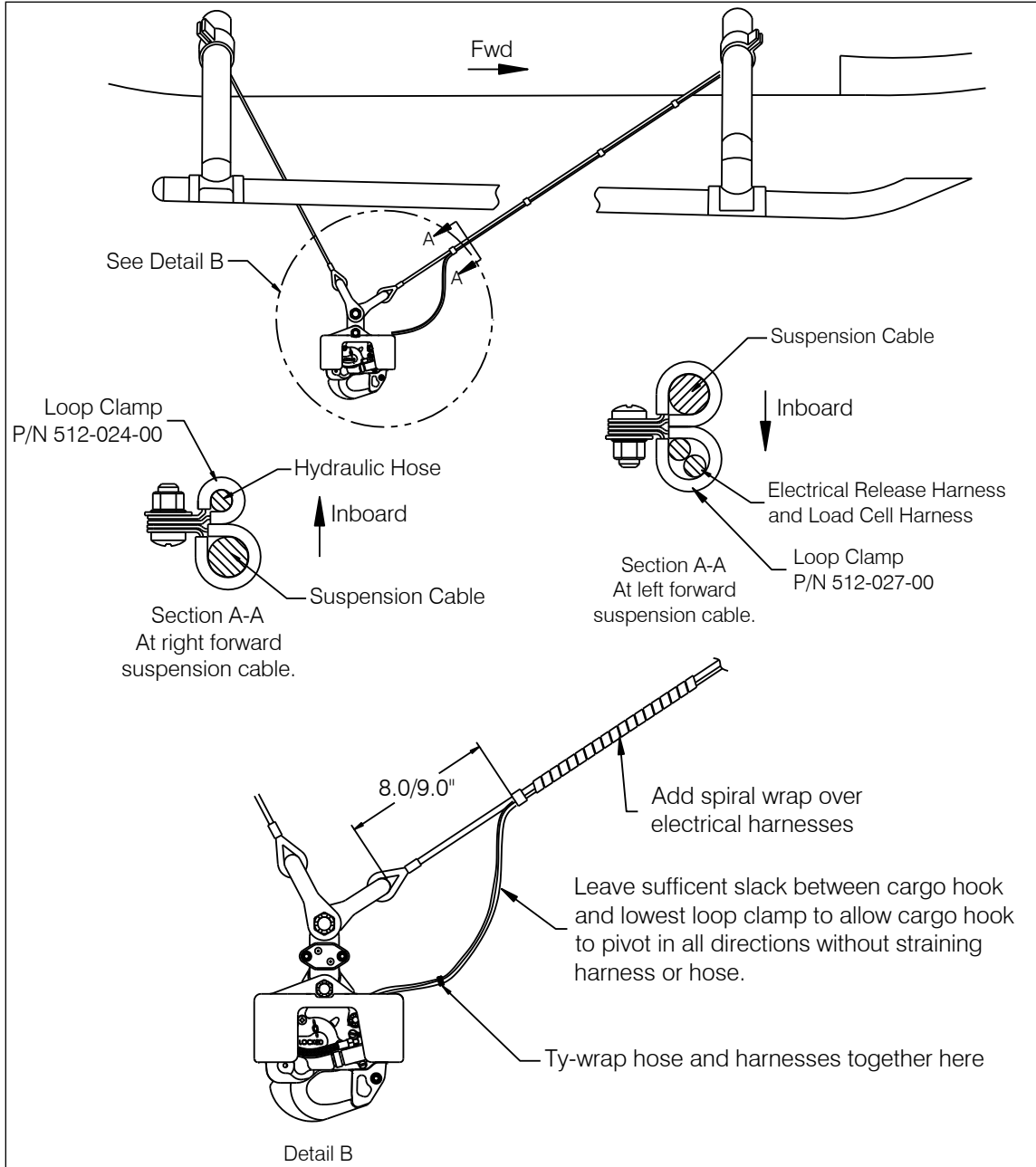

5. Connect the electrical connector to the helicopter's existing electrical release connector in the external skin forward of the left front cable suspension attach point. Secure the release harness and external load cell harness to the skid gear tube, inboard of the suspension attach clamp, with ty-wrap (P/N 512-029-00) as shown in Figure 4.12.

Figure 4.12 Release Harness Tie Off

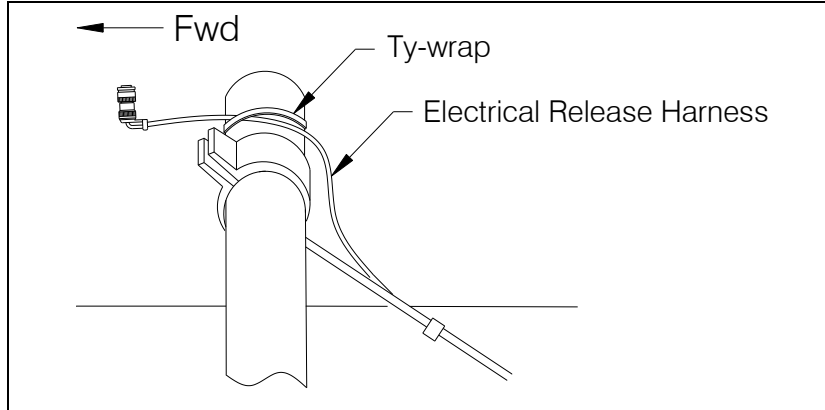

6. Connect the disconnect fitting at the end of the hydraulic hose to the master cylinder hose fitting at the disconnect bracket installed previously.
7. The load cell harness connector is to be connected to the internal harness connector that is installed per section 4.3.
8. Install the "INOP" placard (P/N 215-169-00) over the hook advisory light in the cockpit (the P/N 528-028-00 and 528-028-02 cargo hooks do not have a hook lock indicator switch).
9. If installing cargo hook P/N 528-028-02 (included with kit P/Ns ending in -10) install the Cockpit Decal (P/N 215-343-00) near the Cargo Release switch in clear view of the pilot.

For stowage when not in use, the cargo hook requires that a longer cable sling be installed on the helicopter's existing cargo hook retainer bracket. Remove the existing cable sling and replace with the longer hook retainer sling (P/N 232-218-00) provided, re-using the hardware.

Figure 4.13 Hook Retainer Sling

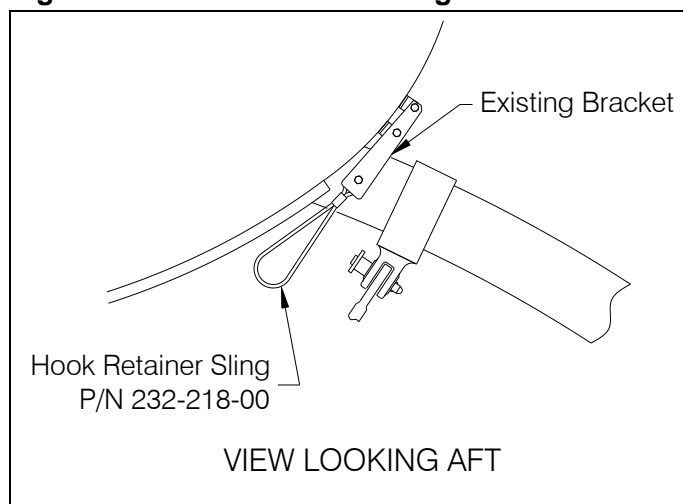

	Owner's Manual	Document Number 120-122-00	Revision 8
		Date 11/03/17	Page 21 of 44

4.3 Load Weigh System Installation

4.3.1 Internal Harness Installation

The Internal Harness is made up of four cables terminated to one connector. The connector is plugged into the back of the Indicator. One of the cables is marked "LOAD CELL" and is fitted with a bulkhead fitting. Another cable is marked "POWER" and is connected to the aircraft electrical power. Another cable is marked "LIGHT", refer to the Indicator Internal Back Light section for installation instructions. The last cable is marked "DATA" and can be connected to the optional Data Recorder or Analog Slave Meter. These optional items are not included under this STC.

NOTICE

The data cable may or may not be terminated with a connector depending on manufacture date.

Figure 4.14 Wiring Arrangement

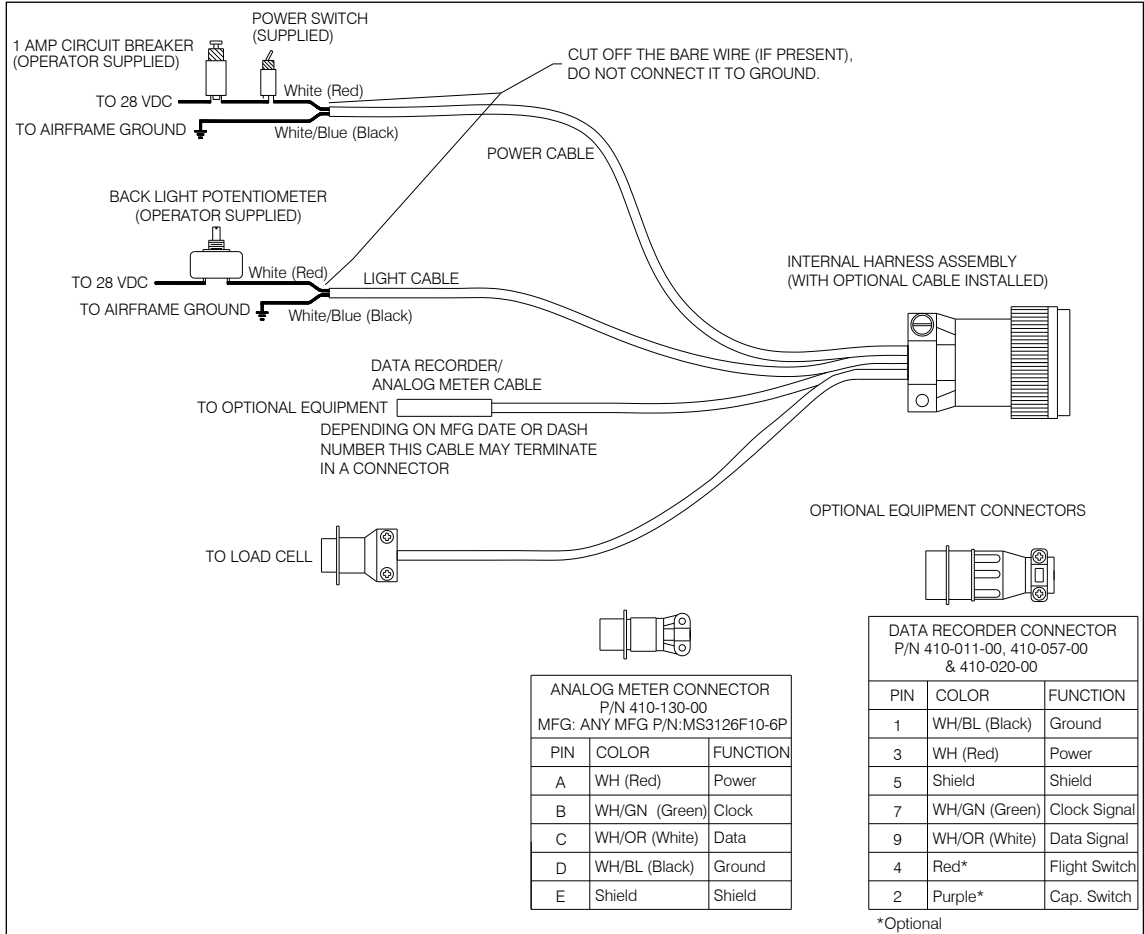

The C-39 Load Indicator, P/N 210-095-00, should be mounted in a position that is convenient, accessible and visible to the pilot. It can be mounted in a standard 2¼" instrument hole.

Install the Load Cell bulkhead connector in the helicopter skin near the electrical release connector, just forward of the left forward cable suspension attachment point. Before installing, verify that the connector from the load cell can reach the location. Mount the connector with the hardware provided.

	Owner's Manual	Document Number 120-122-00	Revision 8
		Date 11/03/17	Page 23 of 44

Route harness wires along existing harnesses while observing the following precautions:

- Pick up existing wire runs by opening existing cable clamps. Nylon ties alone may not be used for primary support.
- The distance between supports should not exceed 21 inches.
- Bend radius of wire or harness must not be less than 10 times the wire or harness diameter.
- Inspect and verify that the wire harness may not be manually deflected into a structure with a bend radius of less than .13 (i.e. – sharp corners which could cause chafing).

Ensure the harness wires are clear of flight control rods.

Connect the Indicator to the Internal Harness.

If it is necessary to remove the load cell bulkhead connector to ease cable routing, reconnect using the color code below.

Table 4.1 Load Cell Bulkhead Connections

Wire Color	Connector Pin
White	A
WH/GN	B
WH/OR	C
WH/BLU	D
Shield	E

4.3.2 Indicator Internal Back Light

The Indicator is equipped with an Internal Back Lighting System that can be connected to the aircraft 28 VDC light dimming circuit. Use a 22 gauge, twisted pair, shielded cable to connect the aircraft dimming circuit to the Internal Harness. Connect the cable shield wire to airframe ground at the light dimmer end of the cable ONLY.

	Owner's Manual	Document Number 120-122-00	Revision 8
		Date 11/03/17	Page 24 of 44

4.3.3 Indicator Hook-Open Warning

The Indicator is equipped with a Hook-Open Warning feature that can be connected to a cargo hook equipped with a hook open switch. Depending on the capabilities of the cargo hook switch, the Indicator will flash "HOOK OPEN" when the cargo hook load beam is open. The cargo hook switch must be normally open when the cargo hook load beam is in the closed position. When the load beam is open, one side of the switch must be grounded and the other side of the switch is to be connected to the Indicator. Use a 22 gauge, shielded wire to connect the cargo hook switch to the Indicator. Disassemble the Indicator mating connector and carefully solder the wire, from the cargo hook switch, to pin H. Connect the cable shield wire to airframe ground as close to the cargo hook as possible, at the cargo hook end of the cable ONLY.

4.3.4 Remote Analog Meter

The Indicator is equipped with an Analog drive circuit that can be connected to a remote analog meter. Use a 22 gauge, twisted pair, shielded cable to connect the Remote Analog Meter to the Indicator. Disassemble the Indicator mating connector and carefully solder the positive wire, from the analog meter, to pin G and the common wire to pin F. Connect the cable shield wire to airframe ground as close to the Analog Meter as possible, at the Analog Meter end of the cable ONLY.

The 210-095-00 Indicator can be connected to Onboard Systems' Analog Slave Meter, P/N 210-180-00, through the "DATA" cable. This meter gives solid weight indications without needle bounce. The Analog Slave Meter may be mounted in any convenient location in a standard 3" instrument hole. Use Cable P/N 270-059-00 to connect the Analog Slave Meter to the Internal Harness "DATA" cable or wire the analog meter connector (P/N 410-130-00) directly to the "DATA" cable (if a connector is not present on this line) using the pin-out in Figure 4.14.

	Owner's Manual	Document Number 120-122-00	Revision 8
		Date 11/03/17	Page 25 of 44

4.3.5 Electrical Connections

Connect the Internal Harness to the Indicator and route the other end of the "POWER" cable to a convenient location for the Indicator power switch (P/N 400-048-00). The cable is supplied extra long, cut off the excess cable and use as needed to connect the switch and circuit breaker. Connect the WH wire in the power cable to one side of the power switch, connect another piece of suitable wire to the other side of the switch and then to an available 1 or 2 amp circuit breaker. Connect the WH/BLU wire to the ground bus. Install the placard 215-010-00 "ELECTRONIC WEIGHING SYSTEM" next to the power switch and circuit breaker. Install the placard 215-012-00 "TURN THE WEIGHING SYSTEM OFF WHEN NAVIGATION EQUIPMENT IN USE" "NO AIRCRAFT OPERATION SHOULD BE PREDICATED ON THE READING OF THE ONBOARD WEIGHING SYSTEM" next to the Indicator.

NOTICE

If the C-23 Printer is being utilized with the C-30 Data Recorder, a 5 amp circuit breaker should be used.

4.4 Filling Hydraulic Release System

Each hydraulic system is typically shipped dry. A label affixed to the Master Cylinder and Slave Cylinder assemblies will state if each hydraulic assembly has been filled and bled. Proper bleeding is critical to the operation of the hydraulic release system. An improperly bled system will not release the cargo hook mechanism.

NOTICE

A reservoir seal is installed beneath the reservoir lid. This seal serves to prevent hydraulic fluid left over from the testing process from leaking during shipping. Remove this before filling and discard or save for future storage of the system.

	Owner's Manual	Document Number 120-122-00	Revision 8
		Date 11/03/17	Page 26 of 44

Filling and bleeding the hydraulic release system is most easily accomplished on the bench, prior to installation on the aircraft. This process may also be accomplished after the system is installed. Filling and bleeding requires two persons, one to inject hydraulic fluid through the system and the other to observe the reservoir.

NOTICE

MIL-PRF-5606 and MIL-PRF-87257 fluids are both compatible with the hydraulic system. These fluids are interchangeable and miscible.

Bleeding procedure:

1. Obtain the hydraulic hook bleed kit, 212-014-02. This kit consists of 2 ounces of MIL-PRF-87257 fluid, a syringe, a female barb fitting, a length of PVC tubing, and a bleed adapter fitting. The bleed kit is included in new hook kits. Assemble the bleed kit by press fitting each component as shown.

Figure 4.15 Hydraulic Hook Bleed Kit

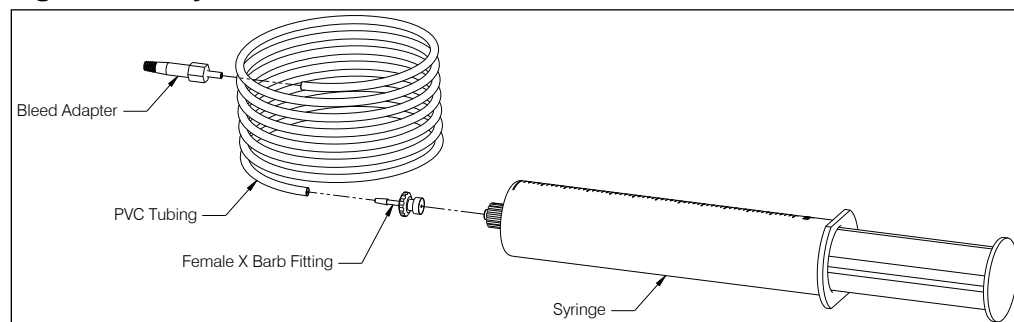

2. If the system is already installed on the aircraft, place an absorbent towel under the master cylinder. If the master cylinder is not installed on the aircraft, lightly clamp the master cylinder in a vise to hold it in a vertical position and position the slave cylinder so that its level is below the level of the master cylinder.

NOTICE

Use best shop practices to keep foreign material out of the hydraulic system. FOD will plug orifices, damage seals and/or scratch sealing surfaces necessitating system rebuild. Use only clean hydraulic fluid from sealed containers.

3. Connect the master cylinder assembly to the slave cylinder assembly if not already done. If filling or bleeding on the bench, as much as possible, arrange the hoses uncoiled, straight and running uphill. See Figure 4.16.

Figure 4.16 Hose Arrangements

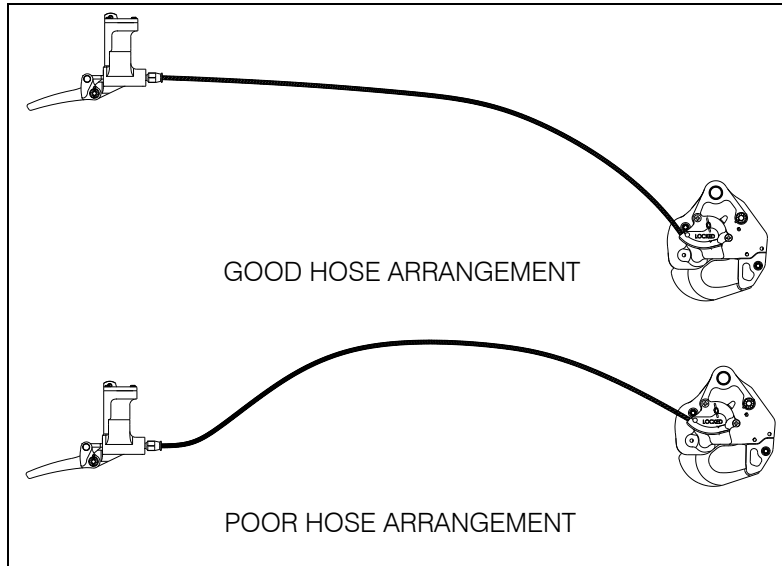

4. Remove screws, reservoir lid, reservoir seal, and baffle from the master cylinder reservoir as shown in Figure 4.17. (The reservoir seal is supplied for shipping purposes only, after removal discard reservoir seal.)

Figure 4.17 Reservoir Disassembly

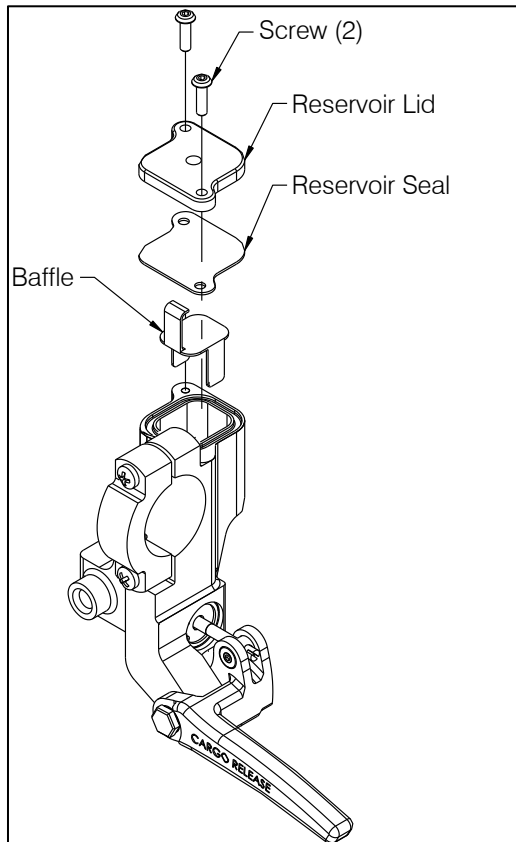

5. Remove the screw and stat-o-seal on the slave cylinder, see Figure 4.18.

Figure 4.18 Screw and Stat-o-seal Removal

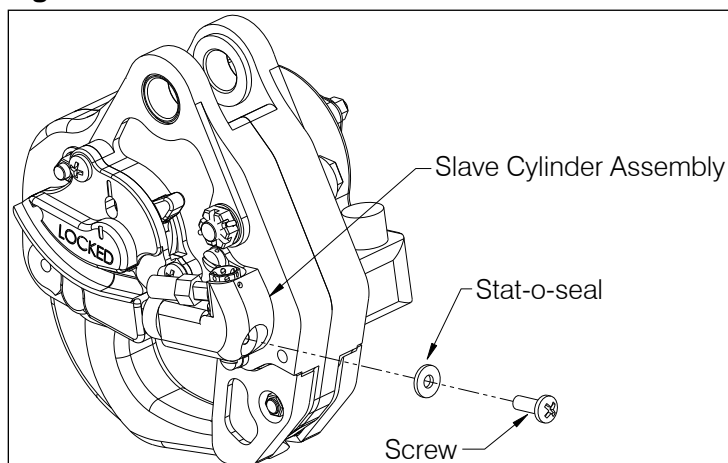

6. Fill a syringe with approximately 35 cc of hydraulic fluid. Screw the end of the syringe into the screw hole on the slave cylinder to create a tight seal. See Figure 4.19.
7. While observing the reservoir, slowly push on the syringe plunger to force fluid through the slave cylinder, hydraulic hose, and up to the master cylinder reservoir. There will be some resistance during filling—this is normal.

CAUTION

Injecting the fluid into the system too rapidly may cause the fluid to spray up and out of the master cylinder reservoir. Wear safety glasses when observing fluid reservoir while filling.

Figure 4.19 Injecting Hydraulic Fluid

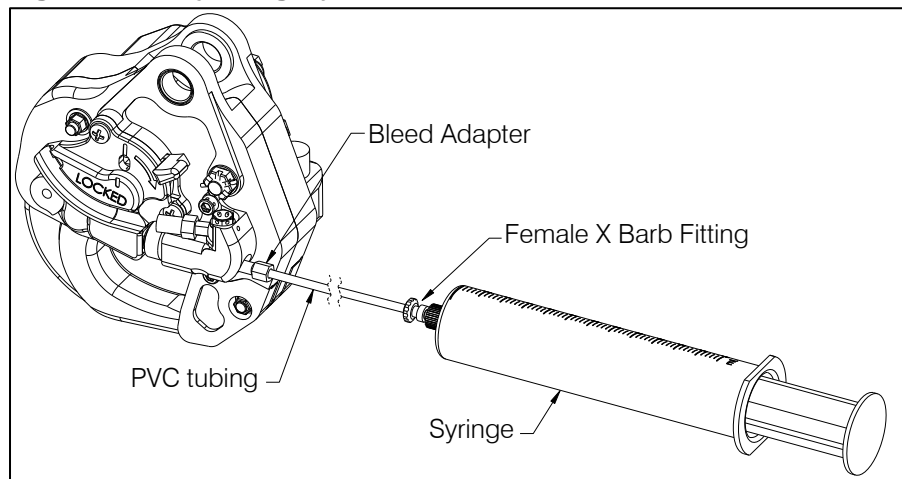

8. Continue to force fluid into the master cylinder reservoir until the reservoir is approximately half full.

NOTICE

If bleeding an already filled system, you may need to draw fluid from the master cylinder reservoir during this step to prevent overflow.

	Owner's Manual	Document Number 120-122-00	Revision 8
		Date 11/03/17	Page 30 of 44

- Remove the syringe from the screw hole. Re-install the Stat-O-Seal (P/N 510-496-00) and screw (P/N 510-493-00), see Figure 4.20.

Figure 4.20 Screw Re-installation

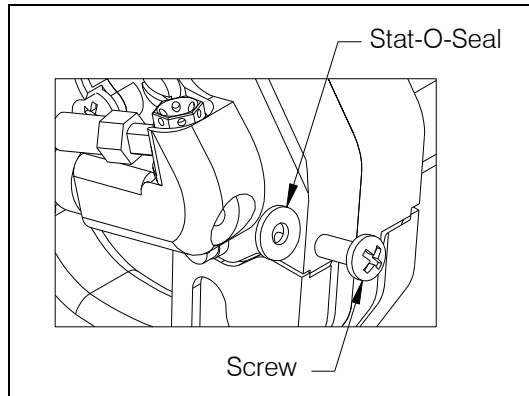

- Allow the system to rest for several minutes. This will allow any air to rise through the system.
- Very slowly pull the release lever on the master cylinder and watch for bubbles. If bubbles are observed rising within the reservoir, continue to slowly cycle the lever until there are no more. Actuating the lever releases air trapped within the master cylinder.



Pull the lever very slowly! When the reservoir is not baffled and capped, a hard pull will cause fluid to erupt over the edge of the reservoir

- Check the system for air by actuating the lever firmly until it bottoms out. Check the push rod position (see Figure 4.21). If the green area on the push rod is visible, proceed to step 13. If the green on the push rod is not visible with the lever completely pulled, the system has too much air in it and needs further bleeding. To do this, repeat steps 5 – 11.

Figure 4.21 Checking System for Air

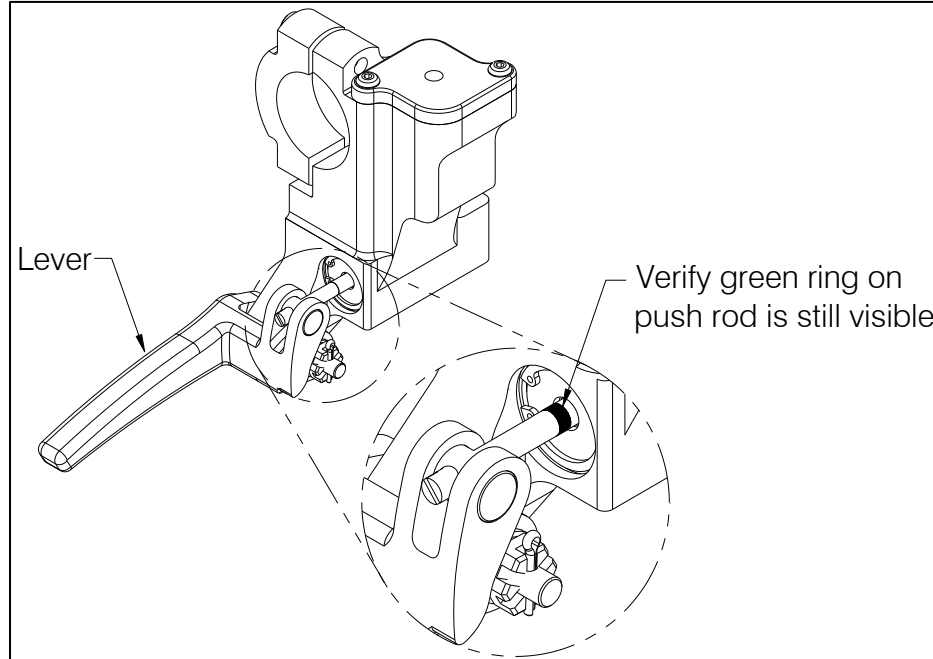

13. After the system is properly bled, verify that the reservoir is approximately half-full of hydraulic fluid. Fluid should be visible above the baffle.
14. Re-install the baffle and the reservoir lid. If the heads on the fasteners are drilled, install safety wire.
15. Check the system for proper operation. Fully actuate the release lever. The hook must open and the lever must have a firm feel.
16. Disassemble and thoroughly clean the syringe with isopropyl alcohol. Allow it to dry. Not cleaning the syringe will render it unusable. Re-assemble and store for next use.

4.5 Installation Check-out

After installation of the Cargo Hook kit and before re-installing belly panels, perform the following functional checks.

1. Swing the installed Cargo Hook to ensure that the hydraulic release hose and the electrical release harness have enough slack to allow full swing of the suspension assembly without straining or damaging them. The hose and/or harness must not be the stops that prevent the Cargo Hook from swinging freely in all directions.
2. Verify that the hydraulic hose routing does not have kinks and is clear of chafing points.

	Owner's Manual	Document Number 120-122-00	Revision 8
		Date 11/03/17	Page 32 of 44

3. Ensure that the collective has full movement and is not restricted by the hydraulic hose routing.
4. Pull the hydraulic release lever on the collective. The Cargo Hook load beam should open.
5. Provide power to the electrical release system. Electrical release system operation depends on the cargo hook P/N installed. The following instructions are applicable to cargo hook P/N 528-028-02 which is equipped with Surefire electrical release. With no load on the cargo hook perform the following.
 - Very briefly press the Cargo Release switch, the cargo hook should not actuate and the load beam should remain closed.
 - Press and hold the Cargo Release switch for a few seconds, the load beam should fall to the open position and the cargo hook solenoid should continue to cycle repeatedly.
 - Push up on the load beam and verify that it latches and the hook lock indicator is aligned with the engraved line on the manual release cover.
 - The following instructions are applicable to cargo hook P/N 528-028-00.
 - Press and release the Cargo Release switch on the cyclic, the load beam should immediately fall to the open position.
 - Push up on the load beam and verify that it latches and the hook lock indicator is aligned with the engraved line on the cover.
6. Pull the cargo hook up to the stowed position and latch it into the retainer sling. Ensure hydraulic hose is free from chafing and kinking and that the electrical harness is protected by the spiral wrap from chafing on the retainer cable.
7. Power on the Indicator and allow it to warm up for 5 minutes (with no load on the hook). Press both Indicator buttons at the same time to go to the Setup Mode. Scroll through the menu until the symbol "0 in" is displayed, then press the right button. Remove any weight that is not to be zeroed out and press either button to complete the procedure.
8. Perform an EMI ground test per AC43.13-1b section 11-107. For equipment that can only be checked in flight an EMI flight test may be required.

4.6 Component Weights

The weights of the Cargo Hook Kits are listed below.

Table 4.2 Component Weights

Item	Weight
200-303-00, -10	8.3 lbs (3.8 kgs)

	Owner's Manual	Document Number 120-122-00	Revision 8
		Date 11/03/17	Page 33 of 44

200-388-00, -10	8.3 lbs (3.8 kgs)
-----------------	-------------------

4.7 Paper Work

In the US, fill in FAA form 337 for the initial installation. This procedure may vary in different countries. Make the appropriate aircraft log book entry. Insert the Rotorcraft Flight Manual Supplement P/N [121-029-00](#) into the Rotorcraft Flight Manual.

5.0 Operation Instructions

5.1 Operating Procedures

Refer to Owner's Manual [120-039-00](#) for operation instructions for the C-39 Load Indicator.

Prior to a flight involving external load operations perform the following.

1. Provide power to the electrical release system. Electrical release system operation depends on the cargo hook P/N installed. The following instructions are applicable to cargo hook P/N 528-028-02 which is equipped with Surefire electrical release. With no load on the cargo hook perform the following.
 - Very briefly press the Cargo Release switch, the cargo hook should not actuate and the load beam should remain closed.
 - Press and hold the Cargo Release switch for a few seconds, the load beam should fall to the open position and the cargo hook solenoid should continue to cycle repeatedly.
 - Push up on the load beam and verify that it latches and the hook lock indicator is aligned with the engraved line on the manual release cover.
 - The following instructions are applicable to cargo hook P/N 528-028-00.
 - Press and release the Cargo Release switch on the cyclic, the load beam should fall to the open position.
 - Push up on the load beam and verify that it latches and the hook lock indicator is aligned with the engraved line on the manual release cover.

CAUTION

The release solenoid is intended to be energized only intermittently. Depressing the electrical release button continuously in excess of 20 seconds will cause the release solenoid to overheat, possibly causing permanent damage.

	Owner's Manual	Document Number 120-122-00	Revision 8
		Date 11/03/17	Page 34 of 44

2. Activate the release lever assembly located on the cyclic stick to check the function of the cargo hook hydraulic release. The load beam should open. Reset the cargo hook load beam by hand after release. Verify that the hook lock indicator on the side of the hook returns to the fully locked position (see Figure 5.1). If the hook does not release or re-latch, do not use the unit until the problem is resolved.

CAUTION

In the fully locked position the hook lock indicator must align with the lines on the manual release cover (see Figure 5.1).

Figure 5.1 Hook Lock Indicator

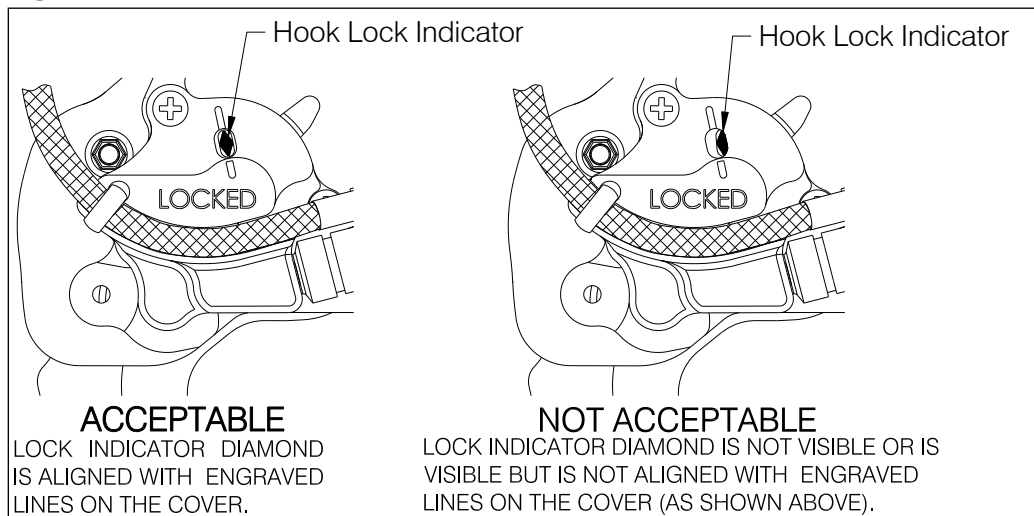

3. Check the hydraulic release system for air by actuating the lever firmly until it bottoms out. Check the push rod position (see Figure 5.2). If some of the green ring on the push rod is visible, the system is adequately bled. If some of the green on the push rod is NOT visible with the lever completely pulled, the system has too much air in it and must be bled.

Figure 5.2 Checking System for Air

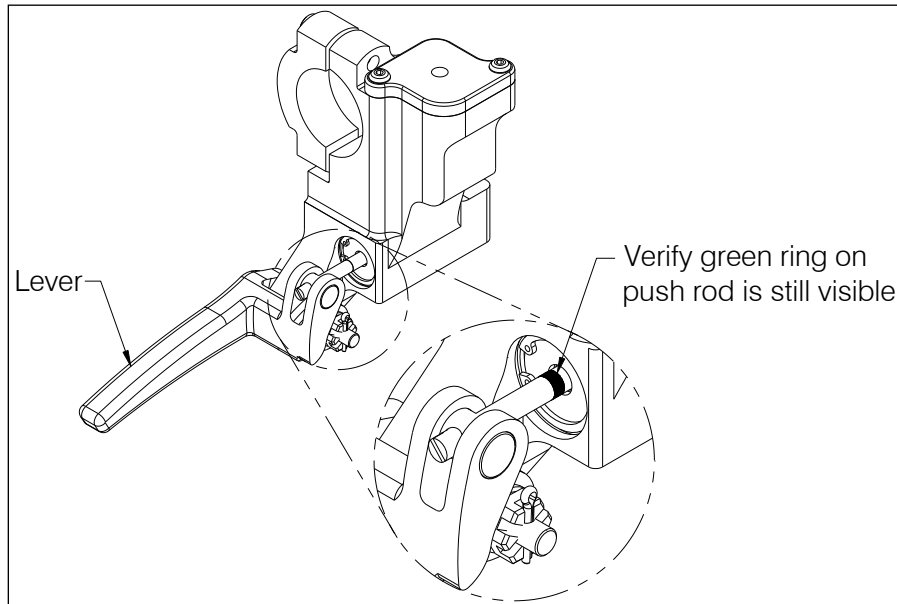

5.2 Cargo Hook Loading

The cargo hook can easily be loaded with one hand. A load is attached to the hook by pushing the ring upward against the upper portion of the load beam throat, as illustrated in Figure 5.3, until an internal latch engages the load beam and latches it in the closed position.

Figure 5.3 Cargo Hook Loading

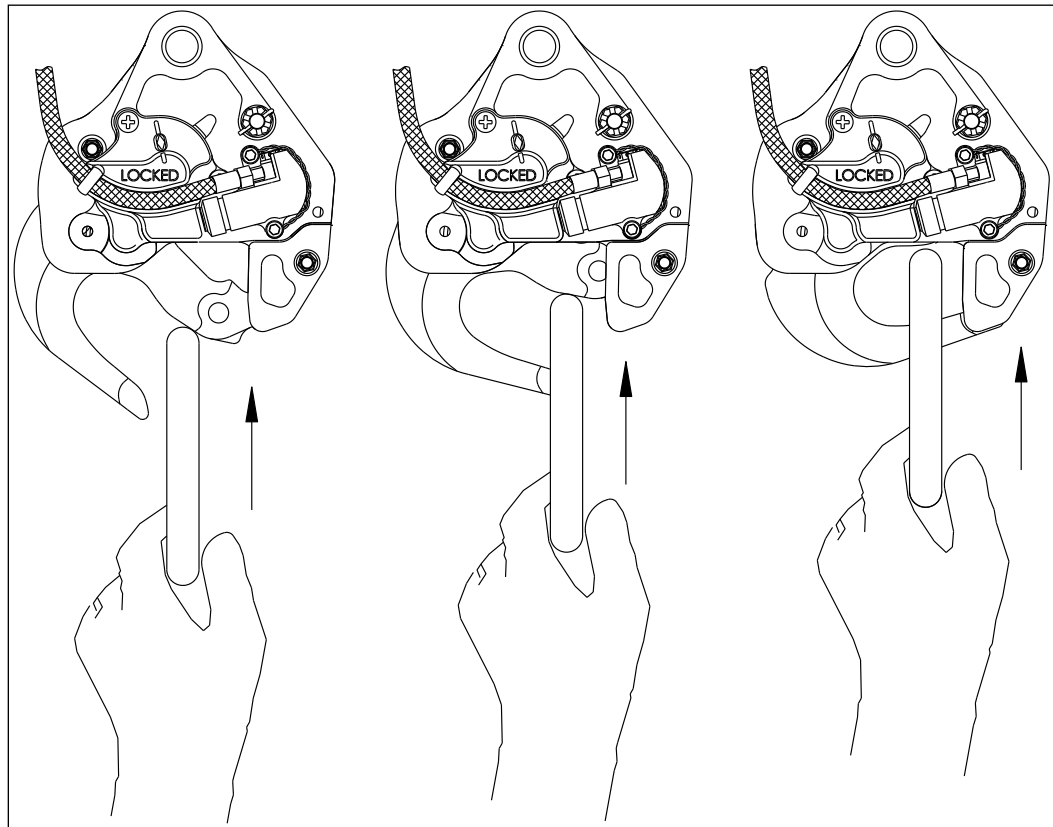

5.3 Cargo Hook Rigging

Extreme care must be exercised when rigging a load to the Cargo Hook. Steel load rings are recommended to provide consistent release performance and resistance to fouling. The following illustration shows the recommended rigging and rigging to avoid but is not intended to represent all rigging possibilities.





Some combinations of small primary rings and large secondary rings could cause fouling during release. It is the responsibility of the operator to ensure the cargo hook will function properly with each rigging.

WARNING

Nylon type straps (or similar material) or rope must not be used directly on the cargo hook load beam. If nylon straps or rope must be used they should be first attached to a steel primary ring. Verify that the ring will freely slide off the load beam when it is opened. Only the primary ring should be in contact with the cargo hook load beam.

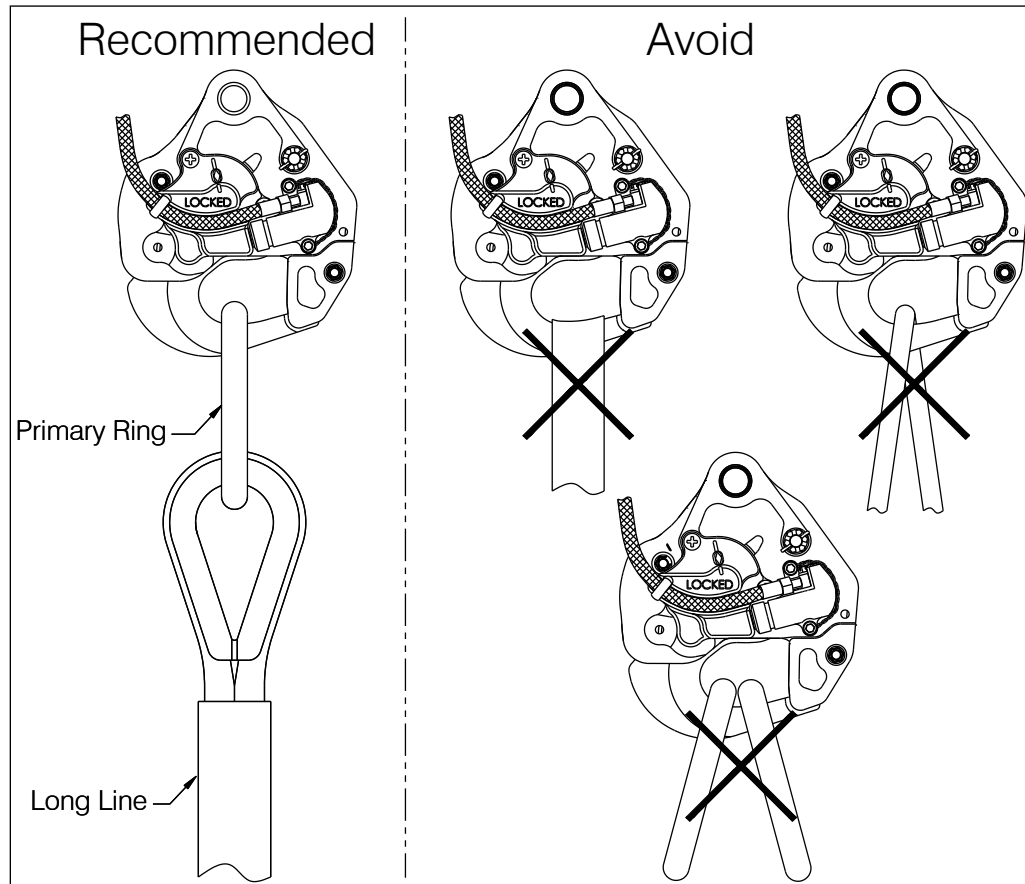
Figure 5.4 Examples of Cargo Hook Rigging



	Owner's Manual	Document Number 120-122-00	Revision 8
		Date 11/03/17	Page 38 of 44

6.0 Maintenance

6.1 Instructions for Returning Equipment to the Factory

If an Onboard Systems product must be returned to the factory for any reason (including returns, service, repairs, overhaul, etc.) obtain an RMA number before shipping your return.



An RMA number is required for all equipment returns.

To obtain an RMA, please use one of the listed methods.

- Contact Technical Support by phone or e-mail (Techhelp@OnboardSystems.com).
- Generate an RMA number at our website: <http://www.onboardsystems.com/rma.php>

After you have obtained the RMA number, please be sure to:



- Package the component carefully to ensure safe transit.
- Write the RMA number on the outside of the box or on the mailing label.
- Include the RMA number and reason for the return on your purchase or work order.
- Include your name, address, phone and fax number and email (as applicable).
- Return the components freight, cartage, insurance and customs prepaid to:

Onboard Systems
13915 NW 3rd Court
Vancouver, Washington 98685
USA
Phone: 360-546-3072

	Owner's Manual	Document Number 120-122-00	Revision 8
		Date 11/03/17	Page 39 of 44

7.0 Certification

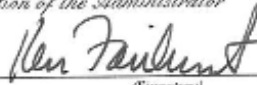
7.1 STC

United States of America Department of Transportation - Federal Aviation Administration <h1 style="margin: 0;">Supplemental Type Certificate</h1> <i>Number</i> SR01694SE	
<i>This certificate, issued to</i>	Onboard Systems 13915 NW 3rd Court Vancouver, WA 98685
<i>certifies that the change in the type design for the following product with the limitations and conditions therefore as specified hereon meets the airworthiness requirements of Part 27 of the Federal Aviation Regulations.</i>	
<i>Original Product—Type Certificate Number:</i>	H3EU
<i>Make:</i>	AIRBUS HELICOPTERS DEUTSCHLAND GmbH
<i>Model:</i>	BO-105S, BO-105LS A-3
<i>Description of the Type Design Change:</i> Installation of Onboard Systems International Cargo Hook Kits and Load Weigh Kit in accordance with the Master Drawing List (MDL) No. 155-113-00, Revision 18, dated June 15, 2016, or later Federal Aviation Administration (FAA) approved revision.	
<i>Limitations and Conditions:</i> This approval should not be extended to other rotorcraft of these models on which other previously approved modifications are incorporated unless it is determined by the installer that the relationship between this change and any of those other previously approved modifications, including changes in type design, will introduce no adverse effect upon the airworthiness of that rotorcraft. Approval of this change in type design applies to only those model rotorcraft listed above which are equipped with a suspension system Part Number (P/N) 105-E0018 installed per Supplemental Type Certificate SH286NE or which are equipped with a Eurocopter suspension system P/N 117-80127, as applicable. This modification must be maintained in accordance with Instructions for Continued Airworthiness (ICA) 123-022-00, Revision 6, dated June 8, 2016, or later FAA-accepted revision. Operated in accordance with Rotorcraft Flight Manual Supplement (RFMS) 121-029-00, Revision 4, dated February 13, 2017, or later FAA-approved revision. A copy of this certificate, the RFMS, the Owner's Manual identified in the MDL, and the ICA, must be maintained as part of the permanent records of the modified rotorcraft.	
If the holder agrees to permit another person to use this certificate to alter the product, the holder shall give the other person written evidence of that permission.	
<i>This certificate and the supporting data which is the basis for approval shall remain in effect until surrendered, suspended, revoked, or a termination date is otherwise established by the Administrator of the Federal Aviation Administration.</i>	
<i>Date of application:</i>	November 21, 2005
<i>Date of issuance:</i>	August 17, 2006
<i>Date revised:</i>	
<i>Date amended:</i>	3/17/11; 3/9/12; 2/16/17
<i>By direction of the Administrator</i>  _____ (Signature)	
 <i>Manager, Seattle Aircraft Certification Office</i> _____ (Title)	
<i>Any alteration of this certificate is punishable by a fine of not exceeding \$1,000, or imprisonment not exceeding 3 years, or both.</i>	
<i>This certificate may be transferred in accordance with FAR 21.47.</i>	

	Owner's Manual	Document Number 120-122-00	Revision 8
		Date 11/03/17	Page 40 of 44

7.2 Transport Canada Approval

 <p> Transport Canada Aviation Suite 620 800 Burrard Street Vancouver, B.C. V6Z 2J8 </p>	Transports Canada Aviation September 14, 2006 Mr. Mark Hansen Onboard Systems 1315 NW 3 rd Court Vancouver, WA 98685 U.S.A.	<p style="font-size: small;"> <i>Your file</i> <i>Notre référence</i> 100S-GA-06-99 <i>Our file</i> <i>Notre référence</i> P-06-0386 RDIMS 2017614 </p>
--	---	---

Dear Mr. Hanson

Subject: Canadian Acceptance of FAA STC SR01694SE

This is in response to the FAA SeattleACO letter dated August 24, 2006, requesting Transport Canada approval of the subject STC.

In accordance with our current policy associated with the review of foreign STCs, some STCs applicable to certain categories of aircraft may be accepted solely on the basis of their foreign certification, and do not require the issue of a corresponding certificate by Transport Canada. The subject STC falls within these criteria.

This STC will be entered in the national index of STCs that have been reviewed and accepted by Transport Canada for installation on Canadian registered aeronautical products.

This letter confirms formal acceptance of the referenced STC by Transport Canada for only those makes and models identified on the subject STC that have been Type Certified or otherwise accepted in Canada.

Yours truly,



Paul Arnell
A/ Regional Manager
Aircraft Certification

c.c. Mr. Jeffrey E. Duven, Manager Seattle Aircraft Certification Services

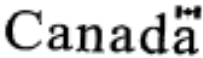

1/1

	Owner's Manual	Document Number 120-122-00	Revision 8
		Date 11/03/17	Page 41 of 44

7.3 ANAC Approval



ANAC
AGÊNCIA NACIONAL
DE AVIAÇÃO CIVIL

CERTIFICADO SUPLEMENTAR DE TIPO
(Supplemental Type Certificate)

NÚMERO **2012S03-06**
(Number)

Este certificado, emitido com base na Lei nº 7565 "Código Brasileiro de Aeronáutica", de 19 de dezembro de 1986,
(This certificate, issued in the basis of the Law No. 7565 "Código Brasileiro de Aeronáutica", dated 19 December 1986,
é conferido ao (à): **Onboard System International**
(is granted to:)
13915 NW 3rd Court
Vancouver, WA 98685
USA

por ter a modificação ao projeto de tipo do produto abaixo citado, observadas as limitações e condições
(For having the change to the type design of the product mentioned below, with the limitations and conditions therefor as)
especificadas, satisfeito aos requisitos de aeronavegabilidade aplicáveis.
(specified hereon, met the applicable airworthiness requirements.)

Produto Original - Número do Certificado de Tipo: EASA.R.011 (EASA)
(Original Product - Type Certificate No:)

Fabricante: Eurocopter Deutschland
(Manufacturer:)

Modelo(s): BO 105 S
(Model(s):)

DESCRIÇÃO DA MODIFICAÇÃO AO PROJETO DE TIPO:
(Description of Type Design Change:)

Installation of Onboard Systems Model 200-387-00 Talon LC Hydraulic Cargo Hook Kit without Load Weigh
or Onboard Systems Model 200-388-00 Talon LC Hydraulic Cargo Hook kit with Load Weigh in accordance
with Onboard Systems Master Drawing List document No. 155-113-00, Rev. 6, dated 09 Apr. 2012, or later
approved revision.

This CST validates in Brazil the STC No. SR01694SE, issued by FAA (USA).

LIMITAÇÕES E CONDIÇÕES:
(Limitations and Conditions:)

See continuation sheet for applicable data.

DATAS:
(Dates of:)

Do Requerimento: 9 Aug. 2010 **Da emissão:** 16 Mar. 2011 **Da reemissão:**
(Application:) (Issue:) (Reissue:)

HÉLIO TARQUÍNIO JÚNIOR
 Gerente-Geral, Certificação de Produto Aeronáutico
 (General Manager, Aeronautical Product Certification)

DINGO ISHIKURA
 Superintendente de Aeronavegabilidade
 (Airworthiness Superintendent)

F-400-01F (03.11) Fl. 01 de 02 H.02-3450-0
(Sheet) (of)

	Owner's Manual	Document Number 120-122-00	Revision 8
		Date 11/03/17	Page 42 of 44



ANAC
 AGÊNCIA NACIONAL
 DE AVIAÇÃO CIVIL

Folha de Continuação ao
 (Continuation Sheet to)



CERTIFICADO SUPLEMENTAR DE TIPO
 (Supplemental Type Certificate)

NÚMERO 2012S03-06
 (Number)

LIMITAÇÕES E CONDIÇÕES:
 (Limitations and Conditions:)

- I. The approval of this type design change should not be extended to other rotorcraft of these models on which other previously approved modifications are incorporated unless it is determined by the installer that the relationship between this change and any of those other previously approved modifications, including changes in Type Design, will introduce no adverse effect upon the airworthiness of that rotorcraft.
- II. If the holder agrees to permit another person to use this certificate to alter the product, the holder shall give the other person written evidence of that permission.
- III. Operation must be performed in accordance with FAA approved Rotorcraft Flight Manual Supplement (RFMS) Document No. 121-029-00, Rev. 3, dated 01 Mar. 2012, or later approved revision.
- IV. Instructions for Continued Airworthiness (ICA) Document 123-022-00, Rev. 4, dated 17 Aug. 2011, or later FAA approved revision and Onboard Systems Service Manual, document No. 122-015-00, Rev. 13, dated 15 Nov. 2011 or later FAA approved revisions are required for this installation.
- V. Approval of this change in type design applies to only the rotorcraft which is equipped with a Eurocopter suspension system P/N 117-80127.
- VI. A copy of this Certificate and the Supplement referred on item III above shall be maintained as part of the permanent records of the modified rotorcraft.

-----END-----

F-400-01F (03.11)

FL 02 de 02
(Sheet) (of)

H.02-3450-0

	Owner's Manual	Document Number 120-122-00	Revision 8
		Date 11/03/17	Page 43 of 44

7.4 EASA STC

Note: This approval is for kit P/N's 200-387-00 and 200-388-00 only.



European Aviation Safety Agency

SUPPLEMENTAL TYPE CERTIFICATE

10040440

This Supplemental Type Certificate is issued by EASA, acting in accordance with Regulation (EC) No. 216/2008 on behalf of the European Community, its Member States and of the European third countries that participate in the activities of EASA under Article 66 of that Regulation and in accordance with Commission Regulation (EC) No. 1702/2003 to

ONBOARD SYSTEMS INTERNATIONAL

13915 NW 3RD COURT
VANCOUVER WA 98685
USA

and certifies that the change in the type design for the product listed below with the limitations and conditions specified meets the applicable Type Certification Basis and environmental protection requirements when operated within the conditions and limitations specified below:

Original Product TC Number : EASA.R.011

TC Holder : EUROCOPTER DEUTSCHLAND GMBH

Model : BO 105 S, BO 105 LS A-3

Original STC Number : FAA STC SR01694SE

Description of Design Change:
Validation of FAA STC SR01694SE - Cargo Hook Kits

EASA Certification Basis:
The Certification Basis for the original product and the following additional or alternative airworthiness requirements are applicable to this certificate/ approval.
FAR 27 including amendment 37
The requirements for environmental protection and the associated certificated noise and/or emissions levels of the original product are unchanged and remain applicable to this certificate/approval.

See Continuation Sheet(s)

For the European Aviation Safety Agency,

Date of issue: 03.07.2012





Massimo MAZZOLETTI
Certification Manager
Rotorcraft, Balloons, Airships

Note:
The following numbers are listed on the certificate:
EASA current Project Number: 0010016454-001

SUPPLEMENTAL TYPE CERTIFICATE - 10040440 - ONBOARD SYSTEMS INTERNATIONAL

EASA Form 91, Issue 4 - 24/09/2010

	Owner's Manual	Document Number 120-122-00	Revision 8
		Date 11/03/17	Page 44 of 44



European Aviation Safety Agency

Associated Technical Documentation:

- FAA approved Onboard Systems Rotorcraft Flight Manual Supplement RFMS 121-029-00, dated March 1, 2012
- or later revisions of the above listed documents approved by EASA in accordance with EASA ED Decision 2004/04/CF (or subsequent revisions of this decision)
- FAA approved Onboard Systems Master Drawing List No. 155-113-00, Revision 10, dated January 10, 2012
- FAA approved Onboard Systems Owners's Manual as listed in FAA STC SR01694SE, amended March 9, 2012
- FAA approved Instructions for Continued Airworthiness as listed in FAA STC SR01694SE, amended March 9, 2012

Limitations:

This STC is restricted to installation of cargo hook kits model 200-387-00 and model 200-388-00. Not included are cargo hook kits model 200-302-00 and model 200-303-00.

Conditions:

Prior to installation of this modification it must be determined that the interrelationship between this modification and any other previously installed modification and/ or repair will introduce no adverse effect upon the airworthiness of the product.

- end -

Note:
The following numbers are listed on the certificate:
EASA current Project Number: 0010016454-001

SUPPLEMENTAL TYPE CERTIFICATE - 10040440 - ONBOARD SYSTEMS INTERNATIONAL

EASA Form 91, Issue 4 - 24/09/2010

2/2