

**PLEASE CHECK WEB SITE AT [WWW.ONBOARDSYSTEMS.COM](http://WWW.ONBOARDSYSTEMS.COM) FOR  
THE LATEST REVISION OF THIS MANUAL**

**Replacement Cargo Hook Kit**  
*For The*  
**Eurocopter AS355 Series**

**Part Number 200-352-00**

**Owner's Manual**

*Owner's Manual Number 120-140-00  
Revision 0  
September 9, 2009*



13915 NW 3<sup>rd</sup> Court Vancouver Washington 98685 USA  
Phone: 360-546-3072 Fax: 360-546-3073 Toll Free: 800-275-0883  
[www.OnboardSystems.com](http://www.OnboardSystems.com)

*This page intentionally left blank.*

## RECORD OF REVISIONS

<i>Revision</i>	<i>Date</i>	<i>Page(s)</i>	<i>Reason for Revision</i>
0	09/09/09	All	Initial Release

### **Register Your Products for Automatic Notifications**

Onboard Systems offers a free notification service via fax or email for product alerts and documentation updates. By registering your Onboard Systems products at our website, we will be able to contact you if a service bulletin is issued, or if the documentation is updated.

You can choose to receive notices on an immediate, weekly, or monthly schedule via fax, email or both methods. There is no charge for this service. Please visit our website at [www.onboardsystems.com/notify.php](http://www.onboardsystems.com/notify.php) to get started.

*This page intentionally left blank.*

# ***CONTENTS***

## ***Section 1* General Information**

Introduction, 1-1  
Warnings, Cautions and notes, 1-1  
Bill of Materials, 1-2  
Inspection, 1-2  
Specifications, 1-3  
Theory of Operation, 1-3

## ***Section 2* Installation Instructions**

Cargo Hook Removal, 2-1  
Cargo Hook Installation, 2-1  
Installation Check-Out, 2-6  
Component Weights, 2-6  
Cargo Hook Location, 2-6  
Paper Work, 2-6

## ***Section 3* Operation Instructions**

Operating Procedures, 3-1  
Cargo Hook Loading, 3-2  
Cargo Hook Rigging, 3-3

## ***Section 4* Maintenance**

Instructions for Returning a System to the Factory, 4-1

## ***Section 5* Certification**

STC, 5-1  
Transport Canada Approval, 5-2  
EASA STC, 5-3

This page intentionally left blank.

# Section 1

## General Information

### Introduction

The 200-352-00 Cargo Hook Kit is approved as a replacement for the following Cargo Hooks on the Eurocopter AS355E, AS355F, AS355F1, AS355F2, AS355N, and AS355NP.

P/N	Manufacture
17149-1	Breeze-Eastern
14027-4	Breeze-Eastern
S1609-3	Siren
S1609-5	Siren
S1609-6	Siren

### Warnings, Cautions and Notes

The following definitions apply to Warnings, Cautions and Notes used in this manual.



*Means that if this information is not observed, serious injury, death or immediate loss of flight safety could occur.*



*Means that there is a risk of injury or degradation in performance of equipment if this information is not observed.*



*Draws the reader's attention to information which may not be directly related to safety, but which is important or unusual.*

## Bill of Materials

The following items are included with the Cargo Hook Kit P/N 200-352-00, if shortages are found contact the company from whom the system was purchased.

**Table 1.1 Bill of Materials**

<b>Part No.</b>	<b>Description</b>	<b>Qty</b>
528-029-00	3.6K Keeperless Hook	1
290-775-00	Attach Bolt	1
290-773-00	Hook Bumper	1
268-030-01	Manual Release Cable	1
410-131-00	Connector	1
510-174-00	Washer	1
510-183-00	Washer	2
510-170-00	Nut	1
510-178-00	Cotter Pin	1
510-455-00	Bolt	1
510-085-00	Washer	1
510-102-00	Nut	1
120-140-00	Owner's Manual	1
121-054-00	RFMS	1
122-017-00	Cargo Hook Service Manual	1
123-035-00	ICA Manual	1

## Inspection

Inspect the cargo hook for evidence of damage, corrosion and security of lock wire and fasteners. If damage is evident, do not use the unit until it has been repaired.



## Specifications

**Table 1.2 Specifications (528-029-00 Cargo Hook)**

Design load	3,600 lbs. (1,633 kg.)
Design ultimate strength	13,500 lbs. (6,123 kg.)
Electrical release capacity	9,000 lbs. (4,082 kg.)
Mechanical release capacity	9,000 lbs. (4,082 kg.)
Force required for mechanical release at 3,600 lb.	8 lbs. Max. (.600" travel)
Electrical requirements	22-32 VDC 6.9 - 10 amps
Minimum release load	0 lbs.
Unit weight	3.0 lbs (1.4 kg.)
Mating electrical connector	PC06P8-2S

## Theory of Operation

The primary elements of the Cargo Hook are the load beam, the internal mechanism, and a DC solenoid. The load beam supports the load and is latched through the internal mechanism. The DC solenoid and an external manual release cable provide the means for unlatching the load beam.

The load is attached to the load beam by passing the cargo sling ring into the throat of the load beam and pushing the ring against the upper portion of the load beam throat, which will initiate the hook to close. In the closed position, a latch engages the load beam and latches it in this position.

To release the load, the latch is disengaged from the load beam. With the latch disengaged, the weight of the load causes the load beam to swing to its open position, and the cargo sling slides off the load beam. The load beam then remains in the open position awaiting the next load.

A load release can be initiated by three different methods. Normal release is achieved by pilot actuation of the push-button switch in the cockpit. When the push-button switch is pressed, it energizes the DC solenoid in the Cargo Hook, and the solenoid opens the latch in the internal mechanism. In an emergency, release can be achieved by operating a mechanical release cable. The release cable operates the internal mechanism of the Cargo Hook to unlatch the load beam. The load can also be released by the actuation of a lever located on the side of the Cargo Hook.

*This page intentionally left blank.*

# Section 2

## Installation Instructions

These procedures are provided for the benefit of experienced aircraft maintenance facilities capable of carrying out the procedures. They must not be attempted by those lacking the necessary expertise.

### Cargo Hook Installation

The cargo hook kit installation requires that the rear lower cowling be modified to add an insert which will be used to attach a support clamp for the supplied manual release cable.

- Remove cargo hook equipment and the rear lower cowling as necessary to install the insert and the support clamp (Eurocopter P/N A3125-2 H179 or equivalent).
- Install an insert in the cowling 9.45 inches (240 mm) aft of and in line with the two holes for the support bracket for the manual release cable junction (see Figure 2.1). Install the insert in accordance with chapter 02.120 of Eurocopter's Standard Practices Manual.
- Install the clamp as shown per section A-A of Figure 2.1 (the clamp is not supplied with the kit, a clamp that supported the OEM manual release cable that was removed can be used).
- Re-install the rear lower cowling onto the helicopter (if removed).

**Figure 2.1 Manual Release Cable Support Clamp**

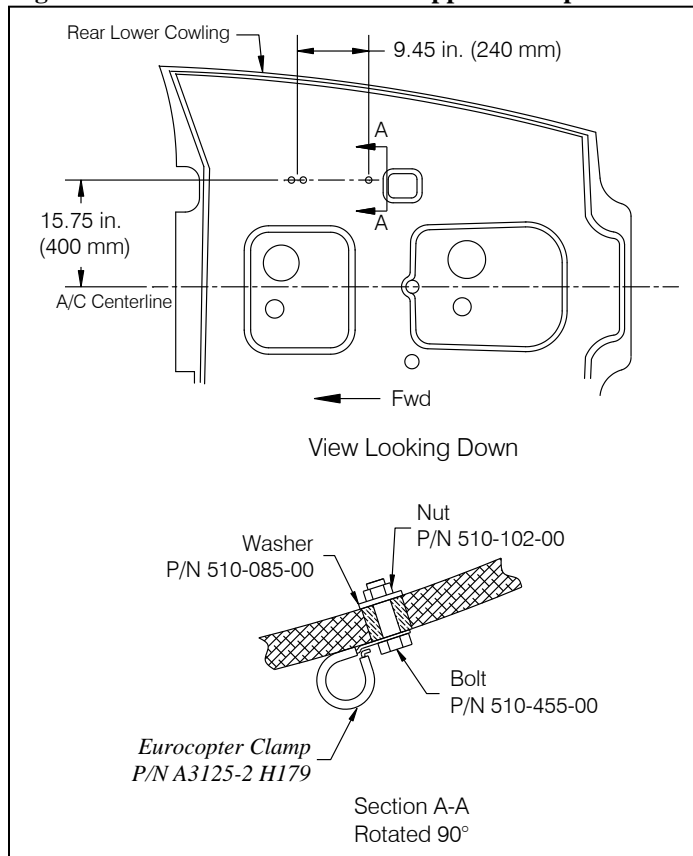

## Cargo Hook Installation continued

Remove the existing cargo hook from the swing suspension by disassembling it from the load cell. Disconnect the electrical release connector from the cargo hook. Remove the existing external manual release cable, it will not be used with the Onboard Systems cargo hook.

- Attach the new cargo hook (P/N 528-029-00) to the load cell (or load link) on the swing suspension using the hardware supplied, as illustrated below. The cargo hook must be oriented as shown in Figure 2.3 when it is installed on the helicopter.
- Re-install the swing suspension onto the helicopter (if it was removed to modify the rear lower cowling).

**Figure 2.2 Cargo Hook Installation**

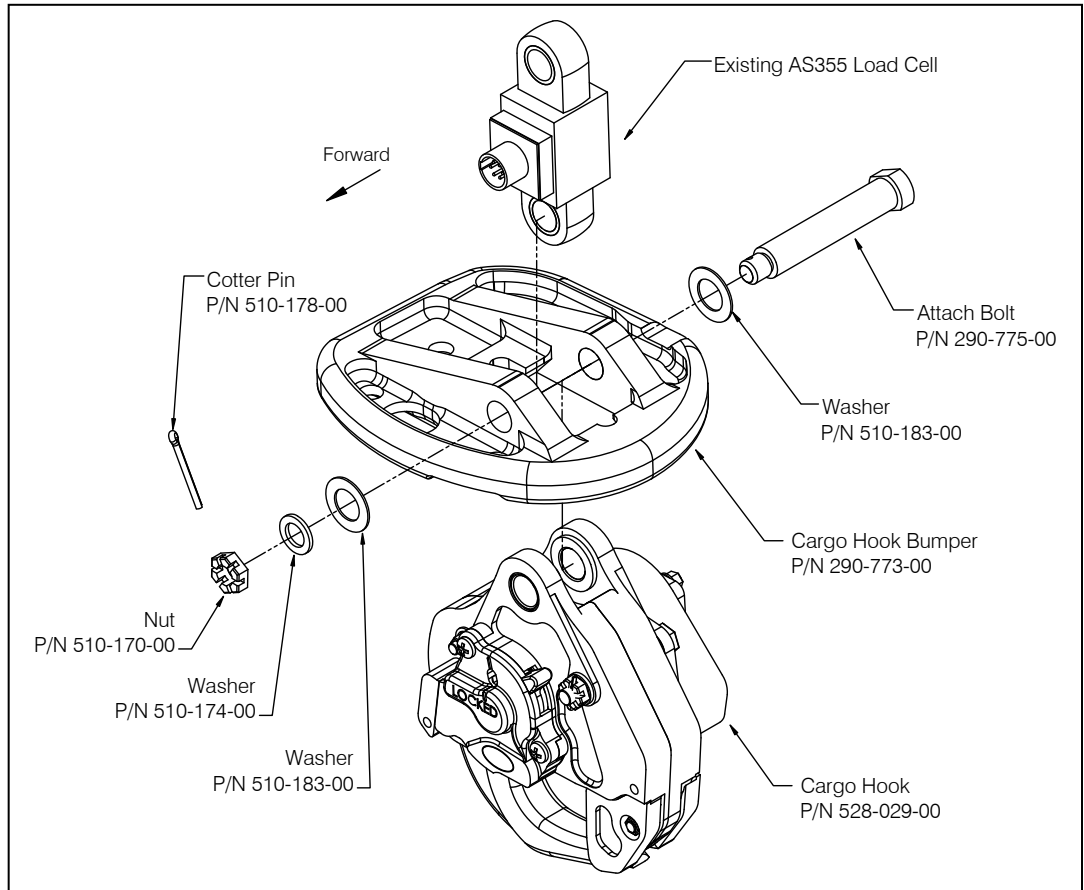

## Cargo Hook Installation continued

**Figure 2.3 Cargo Hook Orientation**

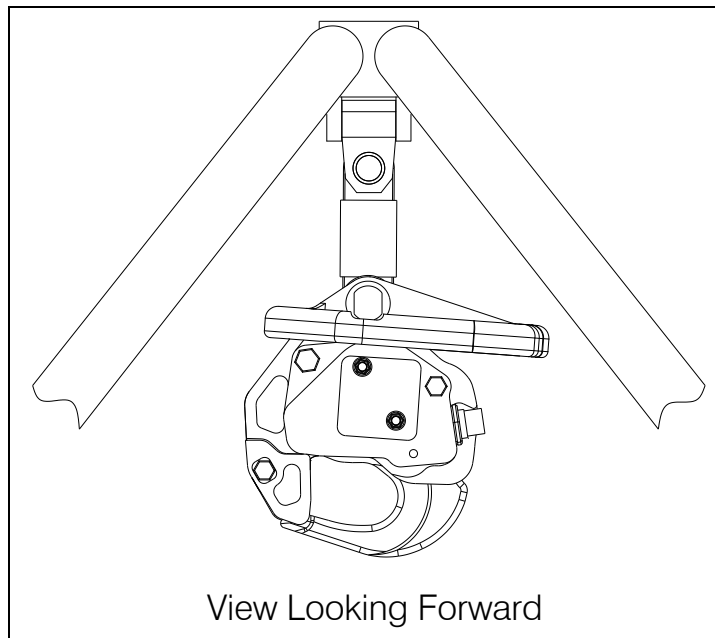

Connect the manual release cable (P/N 268-030-01) to the cargo hook per the following instructions:

- Remove the manual release cover from the cargo hook by removing two screws (see Figure 2.4).

**Figure 2.4 Manual Release Cover Removal**

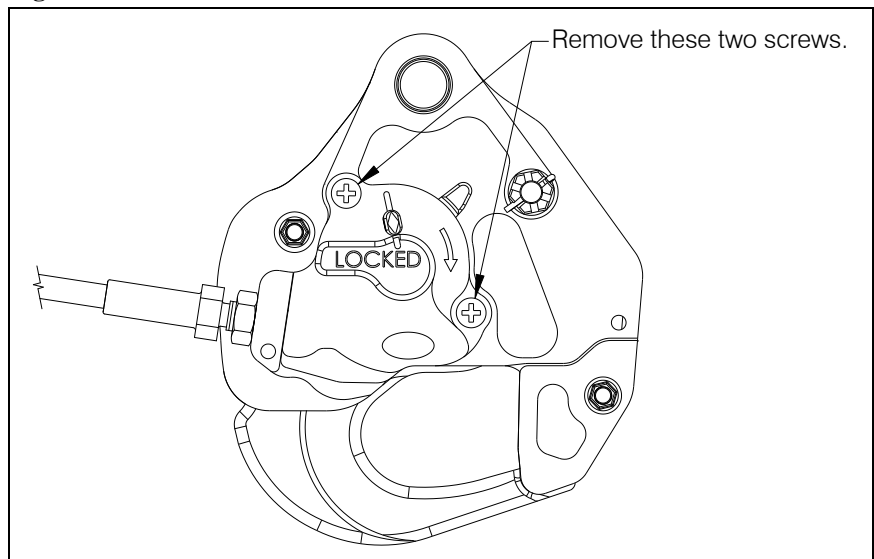

## Cargo Hook Installation continued

- Thread the fitting at the end of the manual release cable into the manual release boss on the cargo hook side plate until the threads protrude approximately .125 inches beyond the boss and secure with jam nut (as shown in Figure 2.5). Leave the manual release cover off of the cargo hook until the other end of the release cable is connected, in order to verify proper setting.

**Figure 2.5 Initial Release Cable Adjustment**

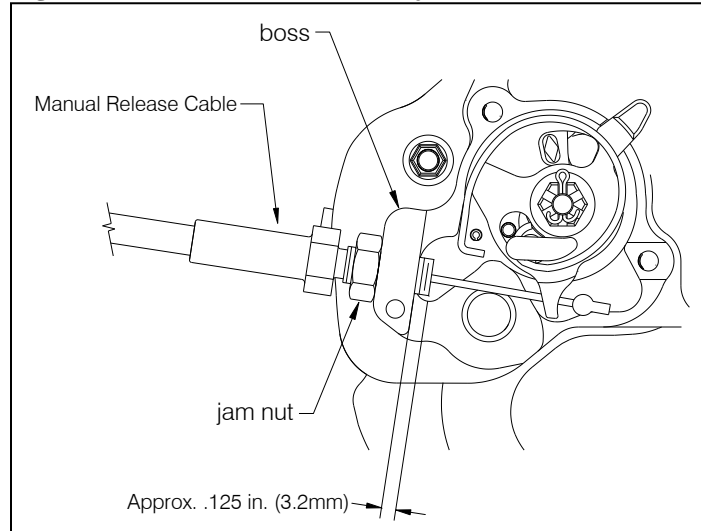

- Route the manual release cable from the cargo hook to the end of the fixed manual release cable as shown below.

**Figure 2.6 Manual Release Cable Routing**

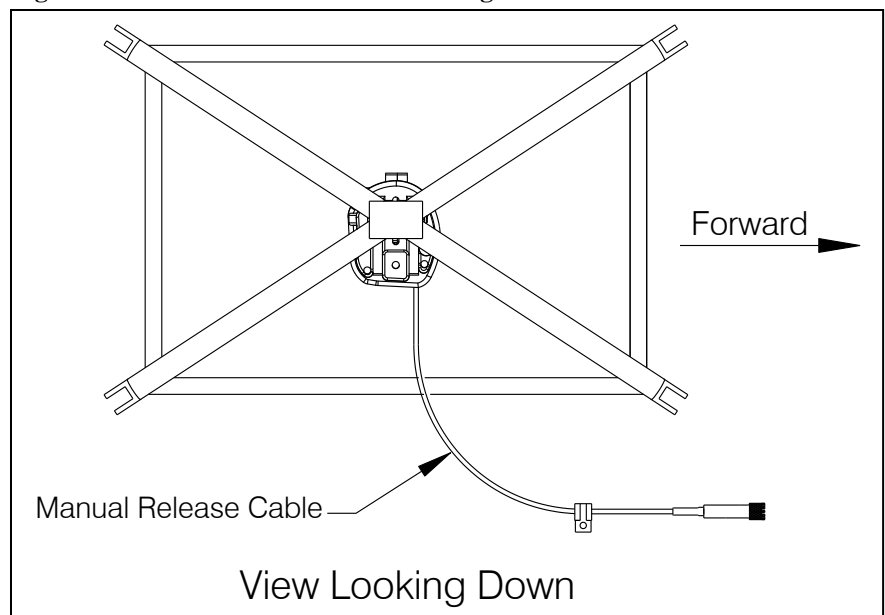

## Cargo Hook Installation continued

- Connect the other end of the manual release cable to the fixed section of the existing AS355 manual release cable by mating the cable end fittings together as shown below (slide back the Adapter Fitting to access fitting on removable cable). Slide the Adapter Fitting forward and thread it onto the existing AS355 fitting, and engage a castellation on the Adapter Fitting with the retaining pin to lock it in place.

**Figure 2.7 Manual Release Cable Junction**

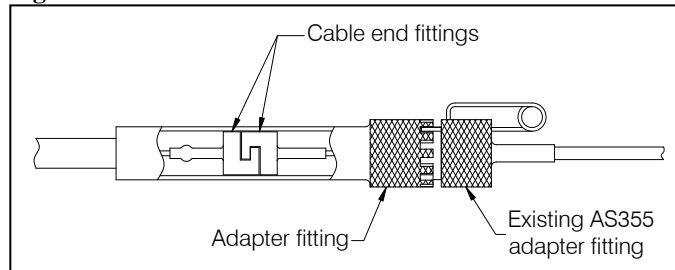

- At the cargo hook, ensure the manual release cable is between the two prongs of the release lever fork as illustrated in Figure 2.8.



*Manual release cable rigging must be done with the cargo hook in the closed and locked position.*

- With the cargo hook closed and locked, rotate the release lever in the clockwise direction to remove free play (the free play is taken up when the hook lock indicator begins to move, this is also felt as the lever rotates relatively easily for several degrees as the free play is taken up) and measure the gap between the cable ball end and the release lever fork with the manual release lever in the cockpit in the non-release position. This gap should be a minimum of .125 inches (3.2 mm) as shown in Figure 2.8.

**Figure 2.8 Manual Release Cable Rigging**

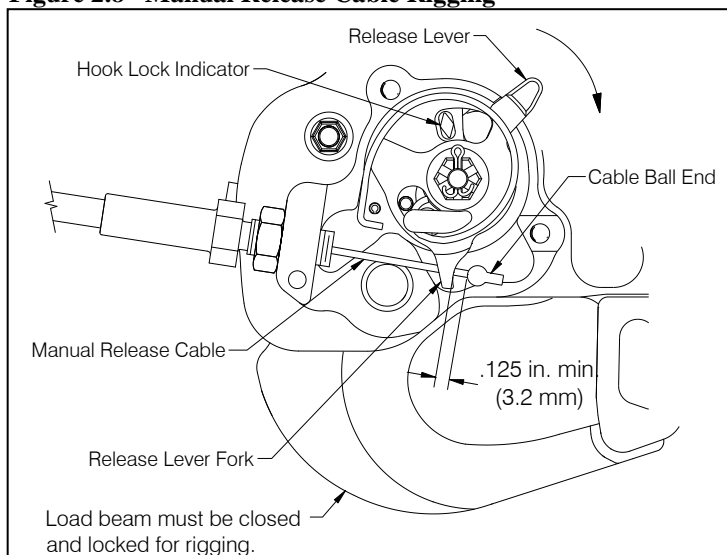

## Cargo Hook Installation continued

- If necessary adjust the manual release cable system to obtain the minimum gap of .125 inches at the release lever fork as shown in Figure 2.5 (the maximum gap is limited by the manual release cover, i.e.- the release cable must fit within the cover when it is installed). The system can be adjusted at the manual release lever on the collective or minor adjustments can be made at the cargo hook by loosening the jam nut and turning the manual release cable in the required direction (this requires that the manual release cable be disconnected from the fixed release cable). Be sure to maintain full thread engagement between the manual release cable fitting and cargo hook.
- Move the cargo hook and suspension throughout their complete range of motion while observing the gap between the release lever fork and cable ball end. At no point should the gap between the release lever fork and cable ball end be less than .030”.
- Re-install the manual release cover with the two screws and ensure the manual release cable jam nut is tightened securely against the cargo hook.



*Un-commanded cargo hook release will happen if the manual release cable is improperly restrained. The cable must not be the stop that prevent the Cargo Hook from swinging freely in all directions. If the Cargo Hook loads cause the hook to strain against the manual release cable the swaged end of the cable may separate allowing the inner cable to activate the cargo hook manual release mechanism. The result is an un-commanded release. Ensure that no combination of cyclic stick or cargo hook position is restrained by the manual or electrical release cables.*

**Figure 2.9 Un-Commanded Release From Incorrectly Secured Cable**

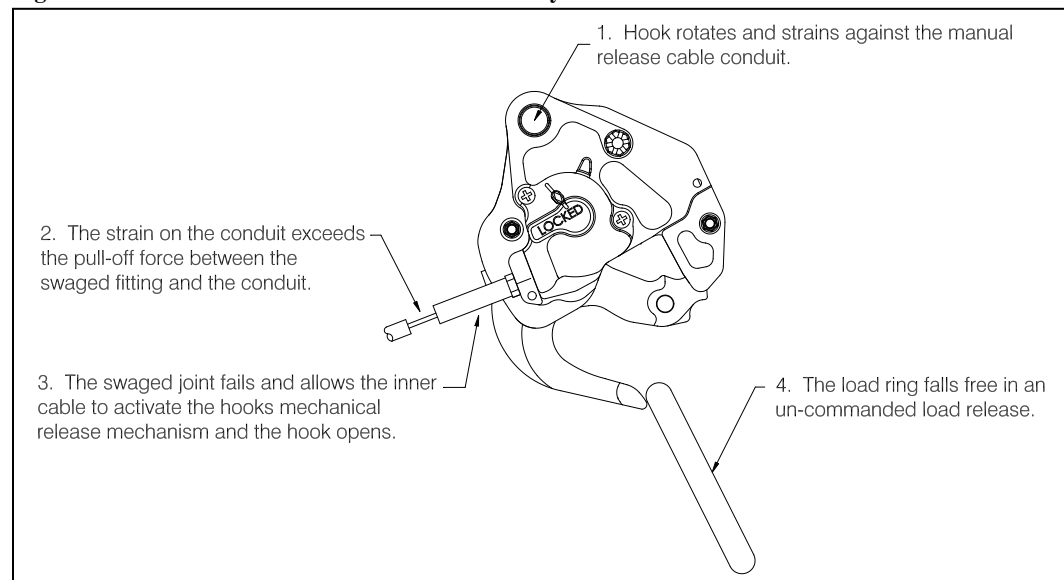



## Cargo Hook Installation continued

The cargo hook kit includes an electrical connector (P/N 410-131-00) to be spliced into the existing Eurocopter harness.

Cut off the existing electrical connector and splice in the supplied connector, referring to Table 2.1 below for cargo hook connector pin out.

**Table 2.1 Cargo Hook Connector**

<i>Pin</i>	<i>Function</i>
A	Ground
B	Power

## Installation Check-Out

After installation of the Cargo Hook, perform the following functional checks.

1. Swing the installed Cargo Hook to ensure that the manual release cable and the electrical release harness have enough slack to allow full swing of the cargo hook and suspension assembly without straining or damaging the cable or harness. The cable and harness must not be the stops that prevent the Cargo Hook from swinging freely in all directions.
2. With no load on the cargo hook load beam pull the lever on the collective to operate the cargo hook mechanical release. The Cargo Hook must release. Reset the cargo hook load beam.
3. Close the cargo hook release circuit breaker and position the battery switch to the ON position. With no load on the cargo hook load beam, depress the cargo hook electrical release button, the Cargo Hook must release. Reset the cargo hook load beam.

## Component Weights

The weight of the Cargo Hook Kit is listed below. Remember to subtract the weight of the cargo hook and components that were replaced.

**Table 2.2 Cargo Hook Kit Weight**

Item	Weight
Cargo Hook Kit	4.3 lbs (1.95 kgs)

## Cargo Hook Location

Refer to the Eurocopter Flight Manual Supplement for external load weight and balance data.

## Paper Work

In the US, fill in FAA form 337 for the initial installation. This procedure may vary in different countries. Make the appropriate aircraft log book entry. Insert the Rotorcraft Flight Manual Supplement P/N 121-054-00 into the Rotorcraft Flight Manual.

# Section 3

## Operation Instructions

### Operating Procedures

Prior to each job perform the following:

1. Ensure that the manual and electrical release cables do not limit the movement of the hook.
2. Be completely familiar with this manual, particularly the Cargo Hook rigging section.
3. Be completely familiar with all Eurocopter Cargo Hook operating instructions and the ICA Maintenance Manual 123-035-00.
4. Activate the electrical system and press the cargo hook release button to ensure the cargo hook electrical release is operating correctly. The Cargo Hook must release. Reset the hook by hand after release. If the hook does not re-latch do not use the unit until the difficulty is resolved.



*The cargo hook release solenoid is intended to be energized only intermittently. Depressing the electrical release button continuously in excess of 20 sec. will cause the solenoid to overheat, possibly causing permanent damage.*

5. Activate the manual release lever to test the cargo hook manual release mechanism. The mechanism should operate smoothly and the Cargo Hook must release. Reset the load beam by hand after release. Verify that the hook lock indicator on the side of the hook returns to the fully locked position. In the fully locked position the hook lock indicator must align with the lines on the manual release cover (see Figure 3.1). If the hook does not release or re-latch, do not use the unit until the problem is resolved.



*In the fully locked position the hook lock indicator must align with the lines on the manual release cover (see Figure 3.1).*

## Operating Procedures continued

**Figure 3.1 Hook Lock Indicator**

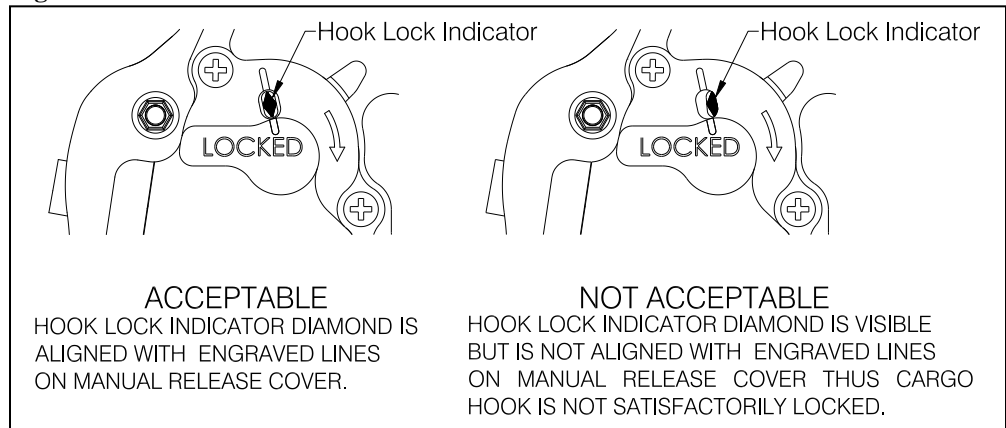

## Cargo Hook Loading

The cargo hook can easily be loaded with one hand. A load is attached to the hook by pushing the ring upward against the upper portion of the load beam throat, as illustrated in Figure 3.2, until an internal latch engages the load beam and latches it in the closed position.

**Figure 3.2 Cargo Hook Loading**

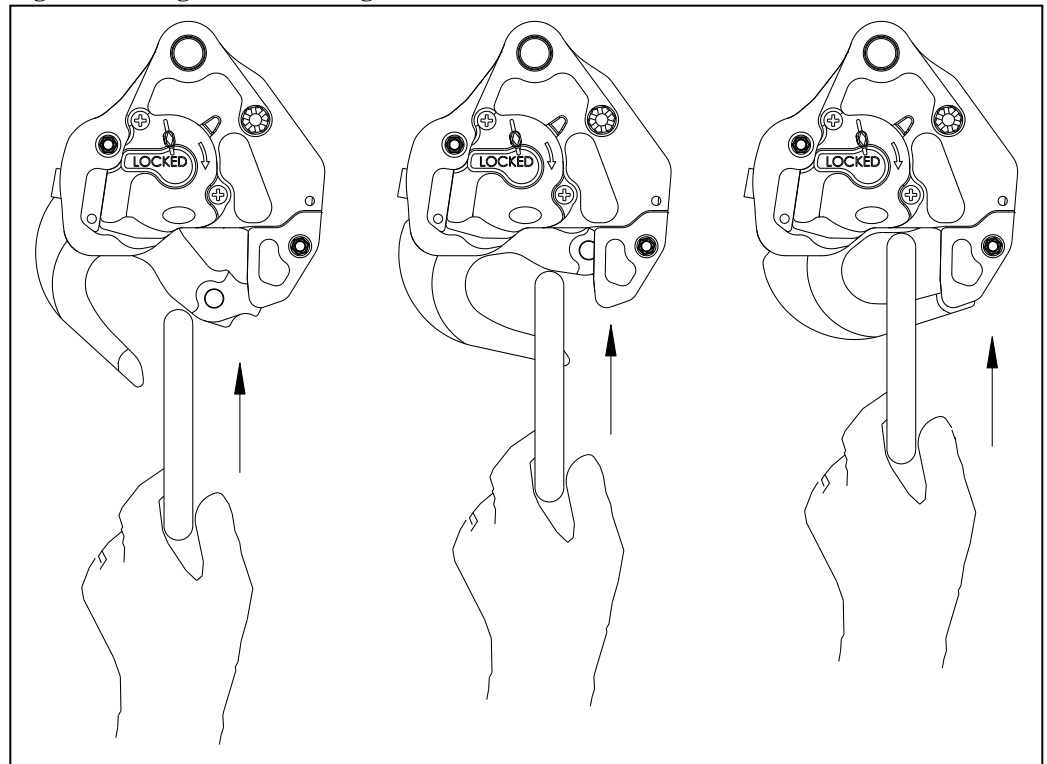

## Cargo Hook Rigging

Extreme care must be exercised when rigging a load to the Cargo Hook. Steel load rings are recommended to provide consistent release performance and resistance to fouling. Figure 3.3 shows the recommended rigging, but is not intended to represent all rigging possibilities.



*Some combinations of small primary rings and large secondary rings could cause fouling during release.*

It is the responsibility of the operator to assure the cargo hook will function properly with each rigging.



*Nylon type straps (or similar material) or rope must not be used directly on the cargo hook load beam. If nylon straps or rope must be used they should be first attached to a steel primary ring. Verify that the ring will freely slide off the load beam when it is opened. Only the primary ring should be in contact with the cargo hook load beam*

## Cargo Hook Rigging continued

Figure 3.3 Example of Recommended Cargo Hook Rigging

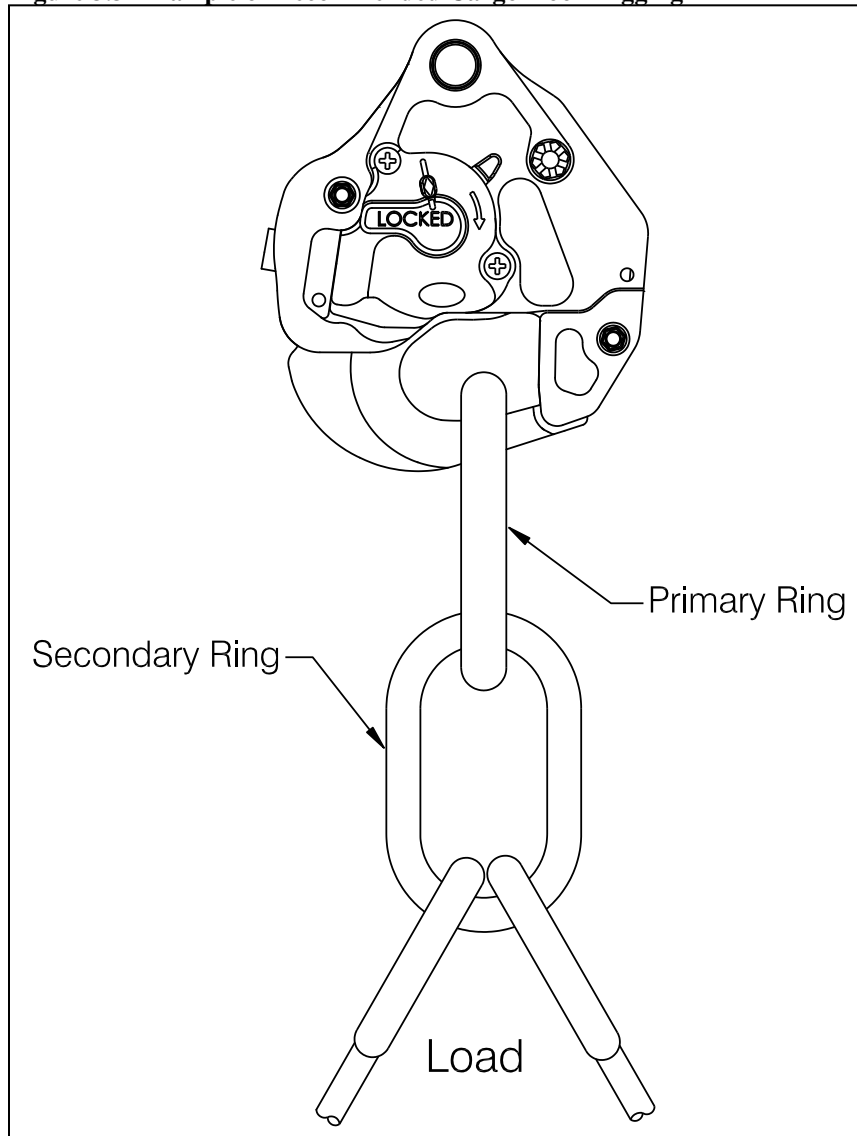

# Section 4

## Maintenance

Refer to the Instructions for Continued Airworthiness (ICA) manual 123-035-00 and Cargo Hook Service Manual 122-017-00 for maintenance.

### Instructions for Returning Equipment to the Factory

If an Onboard Systems product must be returned to the factory for any reason (including returns, service, repairs, overhaul, etc) obtain an RMA number before shipping your return.



*An RMA number is required for all equipment returns.*

- To obtain an RMA, please use one of the listed methods.
  - Contact Technical Support by phone or e-mail ([Techhelp@OnboardSystems.com](mailto:Techhelp@OnboardSystems.com)).
  - Generate an RMA number at our website: <http://www.onboardsystems.com/rma.php>
- After you have obtained the RMA number, please be sure to:
  - Package the component carefully to ensure safe transit.
  - Write the RMA number on the outside of the box or on the mailing label.
  - Include the RMA number and reason for the return on your purchase or work order.
  - Include your name, address, phone and fax number and email (as applicable).
  - Return the components freight, cartage, insurance and customs prepaid to:

Onboard Systems  
13915 NW 3rd Court  
Vancouver, Washington 98685  
USA  
Phone: 360-546-3072

*This page intentionally left blank.*



# Section 5 Certification STC

United States of America  
Department of Transportation Federal Aviation Administration  
**Supplemental Type Certificate**

*Number* SR02035SE

*This certificate, issued to:*

**Onboard Systems International  
13915 NW 3<sup>rd</sup> Court  
Vancouver, WA 98685**

*certifies that the change in the type design for the following product with the limitations and conditions therefore as specified hereon meets the airworthiness requirements of Part 27 of the Federal Aviation Regulations.*

*Original Product—Type Certificate Number:* H11EU  
*Make:* Eurocopter  
*Model:* AS355E, AS355F, AS355F1, AS355F2, AS355N, and AS355NP

*Description of the Type Design Change:* Fabrication of Onboard Systems International Model 200-352-00, Cargo Hook Kit, in accordance with FAA-approved Onboard Systems International Master Drawing List No. 155-145-00, Revision 0, dated September 09, 2009, or later FAA-approved revision; and installation of the 200-352-00, Cargo Hook Kit, in accordance with FAA-approved Onboard Systems International Owner's Manual No. 120-140-00, Revision 0, dated September 09, 2009, or later FAA-approved revision. This modification must be inspected and maintained in accordance with Section ATA 5 of the FAA-approved Onboard Systems International Instructions for Continued Airworthiness (ICA) Document No. 123-035-00, Revision 0, dated November 18, 2009, or later FAA-approved revision and Onboard Systems International Cargo Hook Service Manual No. 122-017-00, Revision 4, dated June 09, 2009, or later FAA-approved revision.

*Limitations and Conditions:* Approval of this change in type design applies only to those Eurocopter model rotorcraft listed above which are equipped with a cargo swing type suspension system. This approval should not be extended to other rotorcraft of these models on which other previously approved modifications are incorporated unless it is determined by the installer that the relationship between this change and any of those other previously approved modifications, including changes in type design, will introduce no adverse effect upon the airworthiness of that rotorcraft. Rotorcraft modified in accordance with this STC must be operated in accordance with a copy of FAA-approved Onboard Systems International Rotorcraft Flight Manual Supplement (RFMS) No. 121-054-00, Revision 0, dated November 16, 2009, or later FAA-approved revision. A copy of this certificate, FAA-approved RFMS, and Maintenance Manual must be maintained as part of the permanent records of the modified rotorcraft.

If the holder agrees to permit another person to use this certificate to alter the product, the holder shall give the other person written evidence of that permission.

*This certificate and the supporting data which is the basis for approval shall remain in effect until surrendered, suspended, revoked, or a termination date is otherwise established by the Administrator of the Federal Aviation Administration.*

*Date of application:* June 12, 2009  
*Date of issuance:* December 09, 2009

*Date reissued:*  
*Date amended:*



*By direction of the Administrator*

*Kenneth B. ...*  
(Signature)

Acting Manager, Seattle Aircraft Certification Office  
(Title)

**Any alteration of this certificate is punishable by a fine of not exceeding \$1,000, or imprisonment not exceeding 3 years, or both.**

*This certificate may be transferred in accordance with FAR 21.47.*

# Transport Canada Approval



Transport  
Canada

Transports  
Canada

Civil Aviation

Aviation Civile

Suite 620  
800 Burrard Street  
Vancouver, B.C.  
V6Z 2J8

*Your file Votre référence*

*Our file Notre référence*

NAPA# P-10-0035  
RDIMS 5793037

April 15, 2010

Mr. Mark Hanson  
Onboard Systems International  
13915 NW 3<sup>rd</sup> Court  
Vancouver, WA 98685  
USA

**Subject: Acceptance of Foreign STC SR02035SE**

Dear Mr. Hanson,

This is in response to FAA letter dated December 24, 2009, Reference 130S-GA-09-096, requesting Transport Canada approval of the subject STC.

In accordance with our current policy associated with the review of foreign STCs, some STCs applicable to certain categories of aircraft may be accepted solely on the basis of their foreign certification, and do not require the issue of a corresponding certificate by Transport Canada. The subject STC falls within these criteria.

This STC will be entered in the national index of STCs that have been reviewed and accepted by Transport Canada for installation on Canadian-registered aeronautical products.

This letter confirms formal acceptance of the referenced STC by Transport Canada.

Yours truly,

Henry Wong  
for Regional Manager  
Aircraft Certification

c.c.: Manager, Seattle Aircraft Certification Office



European Aviation Safety Agency

**SUPPLEMENTAL TYPE CERTIFICATE**

**10030772**

This Supplemental Type Certificate is issued by EASA, acting in accordance with Regulation (EC) No. 216/2008 on behalf of the European Community, its Member States and of the European third countries that participate in the activities of EASA under Article 66 of that Regulation and in accordance with Commission Regulation (EC) No. 1702/2003 to

**ONBOARD SYSTEMS INT.  
13915 NW 3rd COURT  
VANCOUVER WA 98685  
USA**

and certifies that the change in the type design for the product listed below with the limitations and conditions specified meets the applicable Type Certification Basis and environmental protection requirements when operated within the conditions and limitations specified below:

**Original Product TC Number:** EASA.R.146  
**TC Holder:** EUROCOPTER  
**Model:** AS355E, AS355F, AS355F1,  
**Model:** AS355F2, AS355N, AS355NP  
**Original STC Number:** FAA STC SR02035SE

**EASA Certification Basis:**

The Certification Basis for the original product remains applicable to this certificate/ approval. The requirements for environmental protection and the associated certificated noise and/ or emissions levels of the original product are unchanged and remain applicable to this certificate/ approval.

**Description of Design Change:**  
Cargo Hook Kit model 200-352-00

**Associated Technical Documentation:**  
155-145-00 revision 1 dated 28 May 2010 - Master Drawing List;  
120-140-00 revision 0 dated 9 September 2009 - Owners Manual;  
123-035-00 revision 0 dated 18 November 2009 - Service Manual;  
121-054-00 revision 1 dated 11 June 2010 - Rotorcraft Flight Manual Supplement.

**Limitations:**

None See Continuation Sheet(s)

**For the European Aviation Safety Agency,**

**Date of issue: 07.07.2010**

*for Philippe Stabon*  
**Massimo MAZZOLETTI**  
Certification Manager  
Rotorcraft, Balloons, Airships

**Note:**  
The following numbers are listed on the certificate:  
EASA current Project Number: 0010003519-001

**SUPPLEMENTAL TYPE CERTIFICATE - 10030772 - ONBOARD SYSTEMS INT.**

EASA Form 91, Issue 3 - 11/11/2009



## European Aviation Safety Agency

**Conditions:**

Applies only to Eurocopter model rotorcraft listed above which are equipped with a cargo swing type suspension system.

Prior to installation of this modification it must be determined that the interrelationship between this modification and any other previously installed modification and/ or repair will introduce no adverse effect upon the airworthiness of the product.

This Certificate shall remain valid unless otherwise surrendered or revoked.

- end -

Note:  
The following numbers are listed on the certificate:  
EASA current Project Number: 0010003519-001

SUPPLEMENTAL TYPE CERTIFICATE - 10030772 - ONBOARD SYSTEMS INT.

EASA Form 91, Issue 3 - 11/11/2009

2/2