

**PLEASE CHECK WEB SITE AT WWW.ONBOARDSYSTEMS.COM FOR
THE LATEST REVISION OF THIS MANUAL**

***FAA APPROVED
ROTORCRAFT FLIGHT MANUAL
SUPPLEMENT***

STC SR00886SE

***Airbus Helicopters Models
AS350B, AS350B1, AS350B2, AS350B3
AS350BA, AS350D & EC130B4***

R/N _____ S/N _____

FAA Approved:

FAA Manager, Seattle Aircraft Certification Office
Federal Aviation Administration
Renton, Washington

Date: *2/13/2017*



RFM Supplement

Document Number
121-005-01

Cargo Hook

Page
1 of 15

Revision 2

Record of Revisions

Rev.	Date	Page(s)	Reason for Revision
0	10/11/2007	All	Initial Release.
1	07/01/2009	All	Added figure for manual release rigging check, revised figure for hook look indicator for clarification.
2	02/13/2017	All	Updated Limitations section, updated Pre-flight Check and Cargo Hook Rigging sections, added cargo hook P/N 528-029-02 and associated instructions.

	RFM Supplement	Document Number 121-005-01	Rev. 2
	Cargo Hook	Page 2 of 15	FAA Approved FEB 13 2017

1 GENERAL

This supplement must be attached to the appropriate FAA approved Airbus Helicopters' Rotorcraft Flight Manual when an Onboard Systems P/N 200-261-01, 200-353-00 or 200-353-01 Cargo Hook Kit is installed in accordance with Supplemental Type Certificate (STC) No. SR00886SE. The information contained herein supplements or supersedes the basic Rotorcraft Flight Manual only in those areas listed herein. For limitations, procedures and performance information not contained in this supplement, consult the basic Rotorcraft Flight Manual and the applicable Airbus Helicopters' External Load Transport Flight Manual Supplement.

The Cargo Hook Kit, in combination with the rotorcraft's existing cargo hook provisions, provides a means for transporting external loads. The installation includes the cargo hook, a cargo hook bumper, and an external manual release cable to interface with the rotorcraft's internal manual release system. The cargo hook kit also includes an electrical connector that allows it to interface with the rotorcraft's existing cargo hook electrical release system.

	RFM Supplement	Document Number 121-005-01	Rev. 2
	Cargo Hook	Page 3 of 15	FAA Approved FEB 13 2017

2. LIMITATIONS

The limitations specified in the basic Flight Manual and “External Load Transport” Flight Manual Supplement issued by Airbus Helicopters remain applicable and are complemented by the following.

Operating Limitation

With a load attached to the cargo hook, operation shall be conducted in accordance with the respective national operational requirements.

The cargo hook kit configurations (as installed per this STC SR00886SE) do not meet the 14 CFR part 27 certification requirements for Human External Cargo (HEC).

NOTICE

The cargo hook kit equipment certification approval does not constitute operational approval; operational approval for external load operations must be granted by the local Aviation Authority.

! WARNING

Take precautions to prevent external load angles which exceed the limits of rotation provided by the suspension as the load may not be releasable in this position.



RFM Supplement

Document Number
121-005-01

Rev. 2

Cargo Hook

Page
4 of 15

FAA Approved
FEB 13 2017

2 **LIMITATIONS** continued

Maximum load

The maximum load to be carried on the cargo hook is the lesser of that specified by the Airbus Helicopters' External Load Transport Flight Manual Supplement or 3600 lbs (1633 kg).



Placards

The following placards are included with the Cargo Hook Kit.

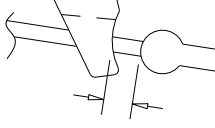
Adhered on the underside of the cargo hook electrical housing:

 WARNING Inadvertent loss of load can result from improper cable adjustment. See manual for complete instructions.	 .13 in / 3.2 mm min
---	---

Attached around the manual release cable:

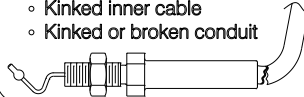
 WARNING <ul style="list-style-type: none">Route to avoid strainRig with proper free playReplace as condition requires (See reverse)See manual for complete instructions	 WARNING <p>Causes for replacement:</p> <ul style="list-style-type: none">Kinked inner cableKinked or broken conduit 
One Side	Opposite Side

2 LIMITATIONS continued

Placards continued

- Adhered on the solenoid housing of optional cargo hook P/N 528-029-02 which is equipped with Surefire Release:



- Adhered adjacent to the cockpit cargo release switch if optional Cargo Hook with Surefire Release P/N 528-029-02 is installed:

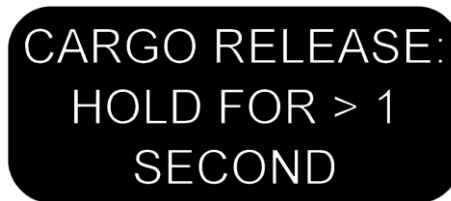

	RFM Supplement	Document Number 121-005-01	Rev. 2
	Cargo Hook	Page 6 of 15	FAA Approved FEB 13 2017

3 **EMERGENCY PROCEDURES**

The emergency procedures specified in the basic Flight Manual and “External Load Transport” Flight Manual Supplement issued by Airbus Helicopters remain applicable and are complemented by the following.



In an emergency such as snagged load or engine failure, the manual release system should be the first option for release of the external load as this system provides greater load release authority in an overload condition. If the manual release option fails, NEXT try the electrical release.

	RFM Supplement	Document Number 121-005-01	Rev. 2
	Cargo Hook	Page 7 of 15	FAA Approved FEB 13 2017

4 NORMAL PROCEDURES

The normal procedures specified in the basic Flight Manual and “External Load Transport” Flight Manual Supplement issued by Airbus Helicopters remain applicable and are complemented by the following.

Pre-Flight Check

Before a flight involving external load operations perform the following procedures. If the procedures are not successful do not use the equipment until the problem has been corrected.

1. Check all mounting fasteners to ensure that they are tight.
2. Check the electrical harnesses and connectors for damage and security.
3. Check the cargo hook exterior for cracks and damage.
4. Swing the cargo hook and the suspension assembly to their full extremes to verify that they do not reach the limit of the range of motion of the electrical harnesses and manual release cable.
5. Visually check the manual release cable for damage and security. Pay close attention to the flexible conduit at the area of transition to the steel fitting at the cargo hook. Check for kinked, broken, or splitting of the heat shrink and outer black conduit in this area and separation of the conduit from the steel fitting.



Manual release cables are wearable items and must be replaced as condition requires. Broken or kinked conduit, inner cable kinks, frays, or sticky operation are each cause for immediate replacement.

	RFM Supplement	Document Number 121-005-01	Rev. 2
	Cargo Hook	Page 8 of 15	FAA Approved FEB 13 2017

Pre-Flight Check continued

6. Cycle the electrical release system to ensure proper operation. The following instructions are applicable to cargo hook P/N 528-029-00.

NOTICE

If Cargo Hook with Surefire Release (P/N 528-029-02) is installed, the electrical release includes a 1/2 second time delay. See specific procedures in this step for this cargo hook model.

- Press the Cargo Release switch on the cyclic, the load beam should fall to the open position.
- Push up on the load beam and verify that it latches and the hook lock indicator is aligned with the engraved line on the manual release cover (see Figure 4.2).

NOTICE

The cargo hook kits use the OEM electrical release switch located on the cyclic. Refer to the Airbus Helicopters RFMS for operational information for the rotorcraft's cargo hook electrical release system.



RFM Supplement

Document Number
121-005-01

Rev. 2

Cargo Hook

Page
9 of 15

FAA Approved
FEB 13 2017

Pre-Flight Check continued

The following instructions are applicable to the optional cargo hook P/N 528-029-02. In addition to the P/N, this cargo hook can also be identified by its gold color solenoid cover (see Figure 4.1).

- *Very* briefly press the Cargo Release switch, the cargo hook should not actuate and the load beam should remain closed.
- Press and hold the Cargo Release switch for several seconds, the load beam should fall to the open position and the cargo hook solenoid should continue to cycle repeatedly.
- Push up on the load beam and verify that it latches and the hook lock indicator is aligned with the engraved line on the manual release cover (see Figure 4.2).

NOTICE

By design (to help protect against inadvertent load release) cargo hook P/N 528-029-02 requires that the Cargo Release switch on the cyclic be held for at least ½ second to release the load.

Figure 4.1 Surefire Configuration Identification

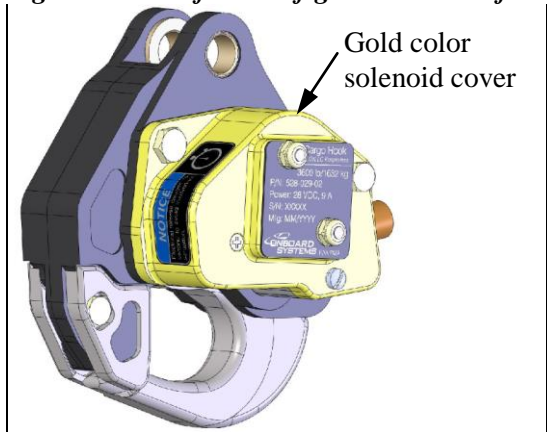

Pre-Flight Check continued

7. Cycle the cargo hook's manual release mechanism to ensure proper operation. Pull the manual release lever in the cockpit. The cargo hook load beam must open. Return the cargo hook load beam to the locked position by manually pushing up on it. The load beam should snap shut. Verify that the hook lock indicator on the side of the hook returns to the fully locked position.



In the closed and fully locked position the hook lock indicator must align with the lines on the manual release cover (see Figure 4.2).

Figure 4.2 Hook Lock Indicator

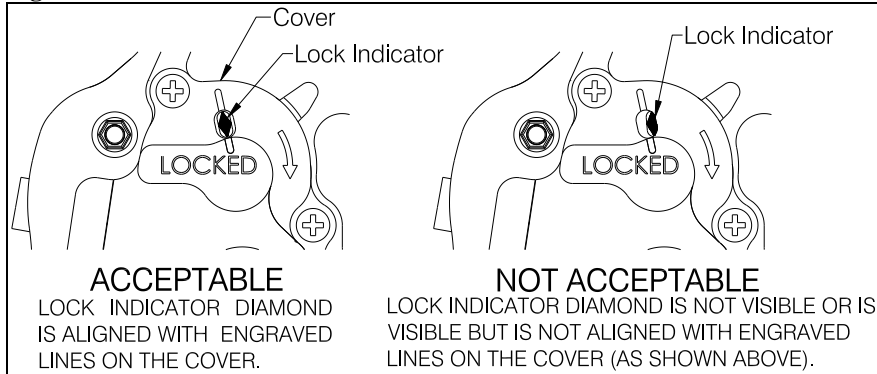

Pre-Flight Check continued

8. Check the manual release cable rigging through the window in the cargo hook manual release cover. Rotate the manual release lever clockwise to remove the free play (the free play is taken up when the hook lock indicator begins to move, this is also readily felt as the lever rotates relatively easily for several degrees as the free play is taken up) and hold it in this position while checking the gap between the release lever fork and the cable ball end as shown below. Visually check that there is approximately a minimum gap of 1/8" (3.2 mm) as shown in Figure 4.3.

Figure 4.3 Manual Release Cable Rigging

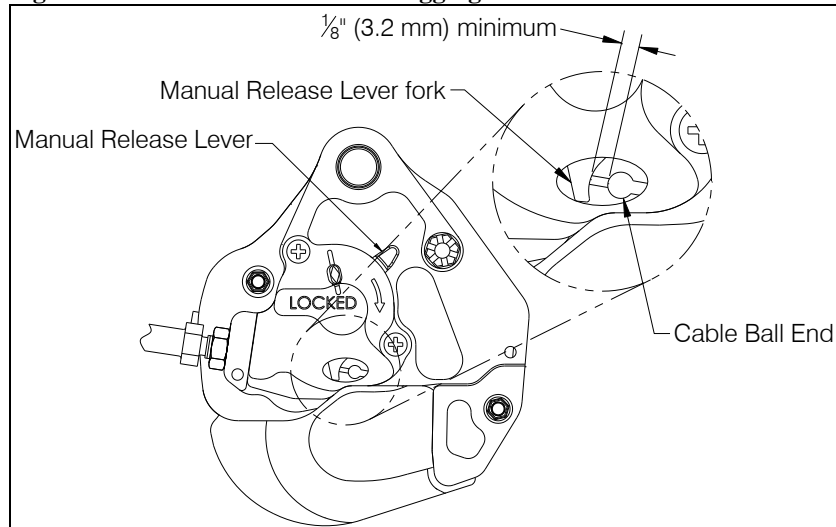

Cargo Hook Rigging

Prior to attaching an external load, instruct the ground crew to ensure that the helicopter has been electrically grounded to discharge static electricity. If possible, maintain ground contact until external load is attached.

Extreme care must be exercised in rigging a load to the Cargo Hook. The following illustration shows the recommended rigging configuration and rigging to avoid.



The examples shown are not intended to represent all possibilities. It is the responsibility of the operator to ensure the hook will function properly with the rigging.



Nylon type straps (or similar material) or rope must not be used directly on the cargo hook load beam. If nylon straps or rope must be used they should be first attached to a steel primary ring. Verify that the ring will freely slide off the load beam when it is opened. Only the primary ring should be in contact with the cargo hook load beam. See Figure 4.4.

Cargo Hook Rigging continued

Figure 4.4 Examples of Cargo Hook Rigging

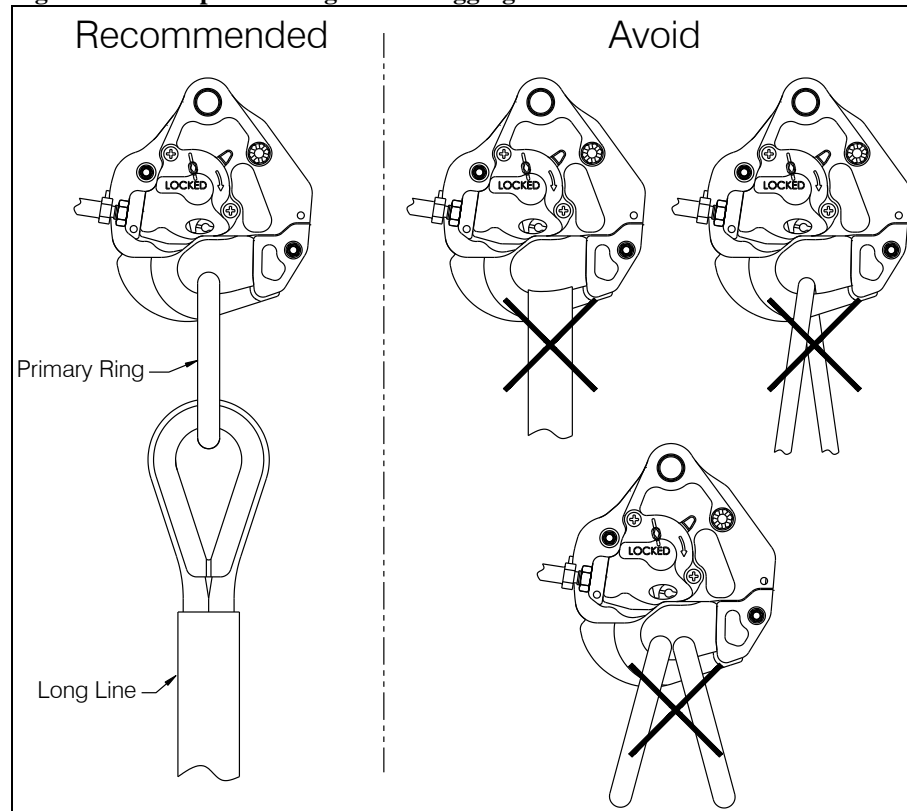

5 PERFORMANCE

The basic Flight Manual and “External Load Transport” Flight Manual Supplement issued by Airbus Helicopters remain applicable.

	RFM Supplement	Document Number 121-005-01	Rev. 2
	Cargo Hook	Page 15 of 15	FAA Approved FEB 13 2017