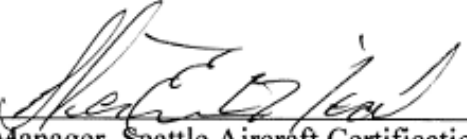

**PLEASE CHECK WEB SITE AT WWW.ONBOARDSYSTEMS.COM FOR
THE LATEST REVISION OF THIS MANUAL**

**FAA APPROVED
ROTORCRAFT FLIGHT MANUAL
SUPPLEMENT
STC SR00896SE
Bell Helicopter Models
206A & 206B**

R/N _____ S/N _____

FAA Approved: 
FAA Manager, Seattle Aircraft Certification Office
Federal Aviation Administration
Renton, Washington

Date: NOV 30 2015



Rotorcraft Flight
Manual Supplement
Bell 206A & 206B Cargo Hook Kit

Document Number	121-008-01
Page	1 of 12
Rev.	1

Record of Revisions

Rev.	Date	Page(s)	Reason for Revision
0	March 4, 2010	All	Initial Release.
1	NOV 30 2015	All	Updated Limitations section. Standardized and updated language and formatting. Expanded pre-flight check.



Rotorcraft Flight
Manual Supplement

Cargo Hook Kit

Document Number
121-008-01

Rev. 1

Page
2 of 12

FAA Approved
NOV 30 2015

INTRODUCTION

This supplement must be attached to the appropriate Bell FAA approved Rotorcraft Flight Manual when an Onboard Systems 200-267-01 Cargo Hook Kit is installed in accordance with Supplemental Type Certificate (STC) NO. SR00896SE. The information contained herein supplements or supersedes the basic manual only in those areas listed herein. For limitations, procedures and performance information not contained in this supplement, consult the basic Rotorcraft Flight Manual and the Flight Manual Supplement for the Cargo Hook issued by Bell.

The 200-267-01 Cargo Hook Kit serves as an upgrade kit for the factory installed cargo hook and interfaces with the helicopter's existing cargo hook provisions including the suspension assembly on the belly. It includes the cargo hook, a manual release cable to interface with rotorcraft's internal manual release system, and a structural link to interface with the suspension assembly.



Rotorcraft Flight
Manual Supplement

Cargo Hook Kit

Document Number

121-008-01

Rev. 1

Page

3 of 12

FAA Approved

NOV 30 2015

1. OPERATING LIMITATIONS

The basic Rotorcraft Flight Manual and Rotorcraft Flight Manual Supplement – Cargo Hook issued by Bell remain applicable and are complemented by the following.

Operating Restrictions

With a load attached to the cargo hook, operation shall be conducted in accordance with the respective national operational requirements. For US operators 14 CFR part 133 is applicable.

The cargo hook kit configuration (as installed in accordance with this STC SR00896SE) does not meet the 14 CFR part 27 certification requirements for Human External Cargo (HEC).

NOTICE

The cargo hook equipment certification approval does not constitute operational approval; operational approval for external load operations must be granted by the local Aviation Authority.

! WARNING

The cargo hook kit's structural link assembly interfaces with the existing Bell link assembly which provide for rotation of the cargo hook with the external load. Take precautions to prevent external load angles which exceed the limits of rotation provided by these assemblies as the load may not be releasable in this position.



Rotorcraft Flight
Manual Supplement

Cargo Hook Kit

Document Number
121-008-01

Rev. 1

Page
4 of 12

FAA Approved
NOV 30 2015

1. OPERATING LIMITATIONS continued

Weight Limitations

Consult the Rotorcraft Flight Manual Supplement – Cargo Hook issued by Bell for Weight Limitations.

The maximum weight to be carried on the cargo hook is the lesser of that specified by the Flight Manual Supplement – Cargo Hook issued by Bell for your particular model or 1500 lbs (680 kg).

Placards and Markings

The following placards are applicable to the 200-267-01 kit.

- Located on the manual release cable near the cargo hook:

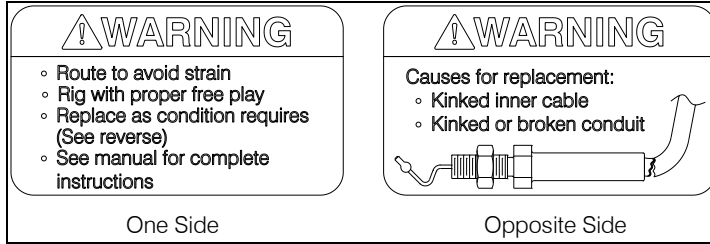

- Located on the bottom of the cargo hook:

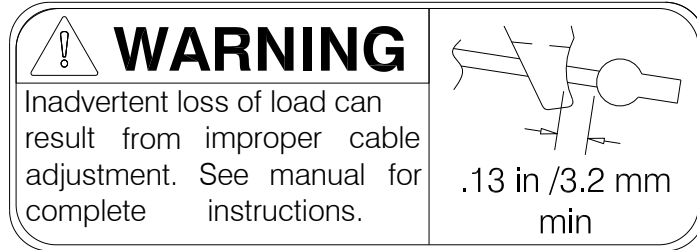

2. NORMAL PROCEDURES

The basic Rotorcraft Flight Manual and Rotorcraft Flight Manual Supplement – Cargo Hook issued by Bell remain applicable and are complemented by the following.

2-3 Pre-flight Check

Prior to a flight involving external load operations perform the following procedures. If the procedures are not successful do not use the equipment until the problem has been corrected.

- 1) Check all mounting fasteners to ensure that they are tight.
- 2) Check the electrical connector for damage.
- 3) Check the case and covers for cracks and damage.
- 4) Check the load beam for gouges and cracks.
- 5) Check the manual release cable for damage, paying close attention to the flexible section at the area of transition to the end fitting (see below). In this area, check for splitting of the heat shrink and kinked or broken conduit underneath and any sign of separation from the steel end fitting.

Figure 2.1 Manual Release Cable Check

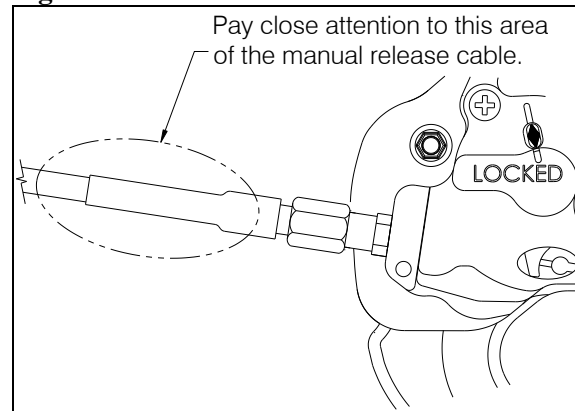

2. **NORMAL PROCEDURES** continued

Pre-flight Check continued

- 6) Cycle the cargo hook's manual release mechanism to ensure proper operation. Pulling up on the manual release T-handle in the cockpit should cause the cargo hook to open. The cargo hook may be returned to the locked position by manually pushing up on the load beam. The load beam should snap shut. The hook may be flown in the open position to facilitate loading by a ground crew.

NOTICE

The cargo hook interfaces with the rotorcraft's manual release system and electrical release system as supplied by Bell. Consult the Flight Manual Supplement – Cargo Hook for operation of these release systems.

- 7) Cycle the cargo hook's electrical release mechanism to ensure proper operation. Pressing CARGO RELEASE switch on cyclic should cause cargo hook to open. The cargo hook may be returned to the locked position by manually pushing up on the load beam. The load beam should snap shut. Verify that the hook lock indicator on the side of the cargo hook returns to the locked position (see Figure 2.2).



Rotorcraft Flight
Manual Supplement

Cargo Hook Kit

Document Number
121-008-01

Rev. 1

Page
7 of 12

FAA Approved
NOV 30 2015

2. **NORMAL PROCEDURES** continued
Pre-flight Check continued



In the fully locked position the hook lock indicator must align with the lines on the manual release cover (see Figure 2.2).

Figure 2.2 Hook Lock Indicator

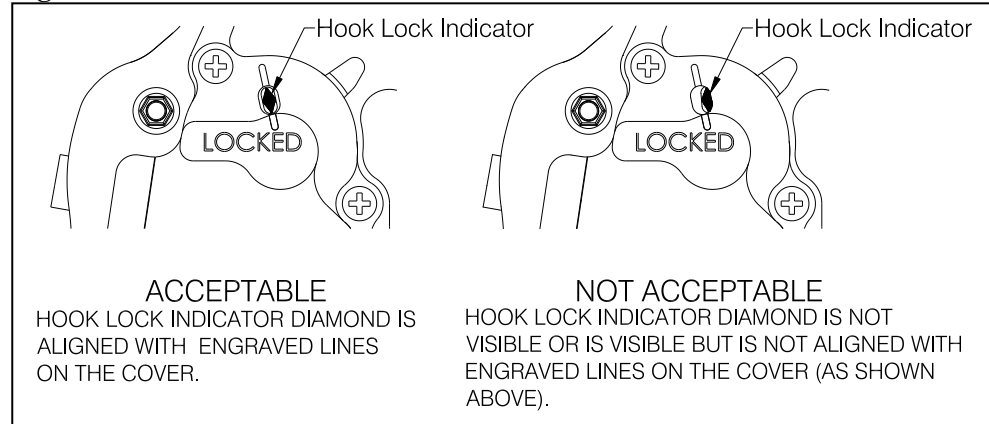

Rotorcraft Flight
Manual Supplement

Cargo Hook Kit

Document Number
121-008-01

Rev. 1

Page
8 of 12

FAA Approved
NOV 30 2015

2. NORMAL PROCEDURES continued

Pre-flight Check continued

- 8) Move the cargo hook throughout its full range of motion to ensure the manual release cable and electrical harnesses have enough slack. The cable or harnesses must not be the stops that prevent the cargo hook from moving freely in all directions.
- 9) Check the manual release cable rigging through the window in the cargo hook manual release cover. Rotate the manual release lever clockwise to remove the free play (the free play is taken up when the hook lock indicator begins to move, this is also readily felt as the lever rotates relatively easily for several degrees as the free play is taken up) and hold it in this position while checking the gap between the release lever fork and the cable ball end as shown below. Visually check that there is approximately a minimum gap of 1/8" (3.2 mm) as shown in Figure 2.3.

Figure 2.3 Manual Release Cable Rigging

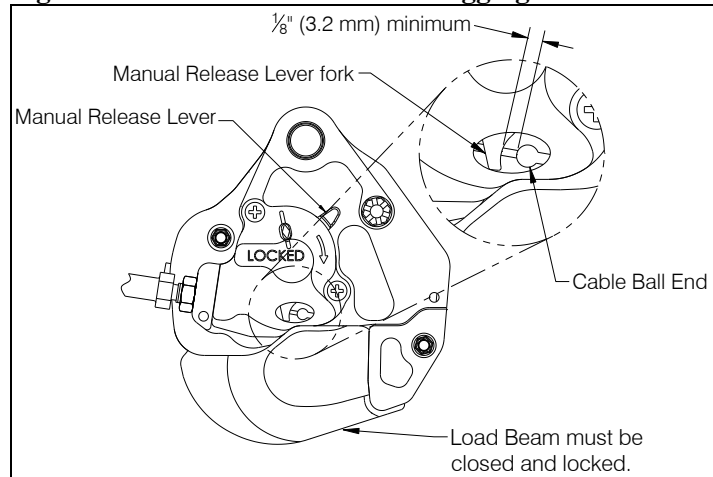

Cargo Hook Rigging

Extreme care must be exercised in rigging a load to the Cargo Hook. The following illustration shows the recommended rigging configuration and rigging to avoid. The examples shown are not intended to represent all possibilities.



It is the responsibility of the operator to ensure the hook will function properly with the rigging.

Nylon Type Straps or Rope



Nylon type straps (or similar material) or rope must not be used directly on the cargo hook load beam. If nylon straps or rope must be used they should be first attached to a steel primary ring. Verify that the ring will freely slide off the load beam when it is opened. Only the primary ring should be in contact with the cargo hook load beam. See Figure 2.4.



Rotorcraft Flight
Manual Supplement

Cargo Hook Kit

Document Number
121-008-01

Rev. 1

Page
10 of 12

FAA Approved
NOV 30 2015

Figure 2.4 Cargo Hook Rigging

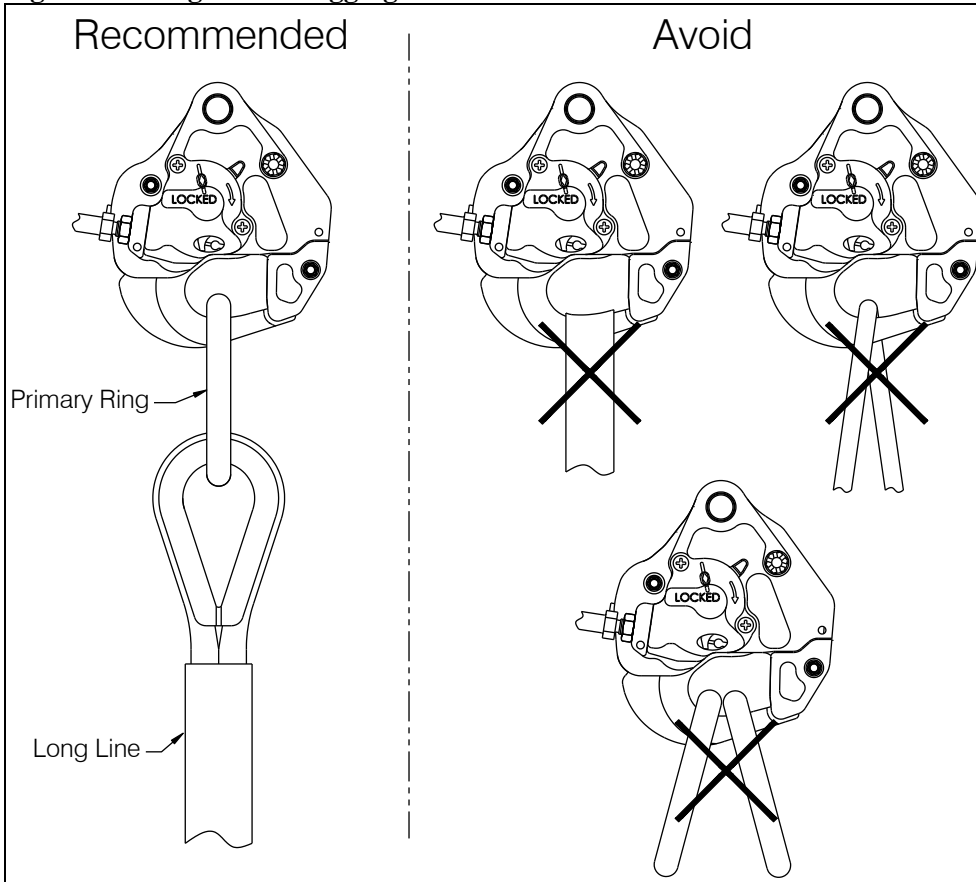

3. EMERGENCY PROCEDURES

The Rotorcraft Flight Manual Supplement – Cargo Hook issued by Bell remains applicable.

4. PERFORMANCE

The Rotorcraft Flight Manual Supplement – Cargo Hook issued by Bell remains applicable.

	Rotorcraft Flight Manual Supplement	Document Number 121-008-01	Rev. 1
	Cargo Hook Kit	Page 12 of 12	FAA Approved NOV 30 2015