

**PLEASE CHECK WEB SITE AT WWW.ONBOARDSYSTEMS.COM FOR
THE LATEST REVISION OF THIS MANUAL**

**FAA APPROVED
ROTORCRAFT FLIGHT MANUAL
SUPPLEMENT**

STC SR01808SE

**Onboard Systems
Cargo Hook Suspension System
with Talon LC Cargo Hook**

Robinson R44, R44 II

R/N _____ S/N _____

FAA Approved: 
Manager, Seattle Aircraft Certification Office
Federal Aviation Administration
Renton, Washington

Date: 10/24/16



RFM Supplement	Document Number 121-051-00
Robinson R44	Page 1 of 24 Revision 3

Record of Revisions

Rev.	Date	Page(s)	Reason for Revision
0	Jan. 07, 2008	All	Initial Release.
1	Feb. 25, 2009	All	Added load weigh kit and accompanying instructions.
2	Mar. 29, 2016	All	Added system description, added remote hook electrical release system, re-formatted document, updated limitations section.
3	Oct. 24, 2016	All	Added "Warning" regarding long line recoil, updated pre-flight check for the C-39 load indicator, added "NOTICE" to note that the Remote Hook is not included with the kits.



RFM Supplement

Robinson R44

Document Number

121-051-00

Rev. 3

Page
2 of 24

FAA Approved

OCT 24 2016

INTRODUCTION

This supplement must be attached to the appropriate FAA approved Rotorcraft Flight Manual when an Onboard Systems 200-324-00, 200-325-00, or 200-325-01 Cargo Hook Suspension Kit is installed in accordance with Supplemental Type Certificate (STC) NO. SR01808SE. The information contained herein supplements or supersedes the basic manual only in those areas listed herein. For limitations, procedures and performance information not contained in this supplement, consult the basic Rotorcraft Flight Manual.

SYSTEM DESCRIPTION

The cargo hook suspension kit provides a means to transport jettisonable external loads. The kit includes the cargo hook, a structural linkage assembly (referred to as suspension assembly) which connects the cargo hook to the existing hard point on the belly of the helicopter and the cargo hook's primary and backup quick release systems for jettisoning of the external load.

In addition to the basic cargo hook suspension kit a second kit configuration (P/N 200-325-01) includes a load weigh system. The load weigh system includes a load cell above the cargo hook which serves as part of the structural linkage, a load weigh indicator and an internal electrical wiring harness. This system provides the pilot with an indication of the weight of the external load being carried.

Either of the basic kit configurations may be complemented by a remote hook release kit (P/N 200-396-00). The remote hook release kit provides the fixed electrical provisions including a release switch on the cyclic grip for the release of a load from a remote cargo hook at the end of a long line.



RFM Supplement

Robinson R44

Document Number

121-051-00

Rev. 3

Page
3 of 24

FAA Approved

OCT 24 2016

SECTION 2 LIMITATIONS

AIRSPEED LIMITS

V_{ne}= 80 KIAS, or less with external load. Do not exceed V_{ne} of basic helicopter (V_{ne} determined from maximum demonstrated airspeed with dense cargo).



Maximum operational air speed with external loads is dependent upon the load configuration and sling length. It is the operator's responsibility to establish the maximum operational speed for each specific configuration.

WEIGHT LIMITS

The maximum Cargo Hook load is 800 lbs (363 kgs). Consult the basic Rotorcraft Flight Manual for weight limits for the rotorcraft.

CENTER OF GRAVITY LIMITS

Center of gravity limits must be checked with and without the external load to verify that the rotorcraft is within the approved center of gravity limits.

The logo for Onboard Systems International, featuring a stylized blue and white graphic of a rotorcraft above the text "ONBOARD SYSTEMS" in bold, black, sans-serif capital letters, with "INTERNATIONAL" in smaller, blue, sans-serif capital letters below it.	RFM Supplement	Document Number 121-051-00	Rev. 3
	Robinson R44	Page 4 of 24	FAA Approved OCT 24 2016

KINDS OF OPERATION LIMITATIONS

The basic Flight Manual remains applicable. With a load attached to the cargo hook, operation shall be conducted in accordance with the respective national operational requirements.

These cargo hook kits (as installed per this STC) do not meet the 14 CFR part 27 certification requirements for Human External Cargo (HEC).

NOTICE

The cargo hook equipment certification approval does not constitute operational approval; operational approval for external load operations must be granted by the local Aviation Authority.

! WARNING

The suspension assembly is designed to allow the cargo hook to pivot and align with the external load in all directions with limits to protect the electrical and manual release cables from damage. Take precautions to prevent external load angles which exceed the limits of rotation provided by the suspension as the load may not be releasable in this position.

The optional remote hook electrical release kit (P/N 200-396-00) is limited for use with intermittent electrical loads only such as an electrical release of a remote cargo hook.



RFM Supplement

Robinson R44

Document Number

121-051-00

Rev. 3

Page
5 of 24

FAA Approved

OCT 24 2016

KINDS OF OPERATION LIMITATIONS

The helicopter may also be operated with the fixed provisions portion of the kit installed only. This includes the suspension assembly, stowed manual release cable, and all Cargo Hook related equipment in the cockpit.

PLACARDS

The following placards are included with the kits.

 WARNING EXTERNAL LOAD LIMIT 800 LB (363 KG) <small>215-119-00</small>	
<p>Mounted on the belly of the aircraft adjacent to the cargo hook attachment point in clear view of the ground support personnel.</p>	
<p>FOR FAR PART 133.35(A) OPERATIONS: NO PERSON MAY BE CARRIED UNLESS HE IS: (1) A FLIGHT CREW MEMBER OR TRAINEE; (2) PERFORMS AN ESSENTIAL FUNCTION IN CONNECTION WITH THE EXTERNAL LOAD OPERATION; OR (3) IS NECESSARY TO ACCOMPLISH THE WORK ACTIVITY DIRECTLY ASSOCIATED WITH THAT OPERATION.</p>	
<p>Mounted in the cockpit in view of the pilot.</p>	
CARGO RELEASE	<p>Mounted adjacent to the manual release in clear view of the pilot.</p>
CARGO RELEASE	<p>Mounted adjacent to the electrical release switch in clear view of the pilot.</p>



RFM Supplement

Document Number
121-051-00

Rev. 3

Robinson R44

Page
6 of 24

FAA Approved
OCT 24 2016

PLACARDS continued

<p>CARGO RELEASE</p>	<p>Mounted adjacent to the co-pilot's electrical release switch (if optional co-pilot's release switch is installed).</p>
<p>PULL</p>	<p>Mounted adjacent to the manual release in clear view of the pilot.</p>
<p>CARGO</p>	<p>Mounted adjacent to the Cargo Hook circuit breaker in clear view of the pilot.</p>
<p>REMOTE HOOK</p>	<p>When 200-396-00 kit is installed, mounted adjacent to the circuit breaker in full view of the pilot and co-pilot.</p>
<p>REMOTE HOOK</p>	<p>When 200-396-00 kit is installed, mounted on the face of the remote hook release switch housing in full view of the pilot and co-pilot.</p>



RFM Supplement

Robinson R44

Document Number

121-051-00

Rev. 3

Page
7 of 24

FAA Approved

OCT 24 2016

PLACARDS continued

ELECTRONIC WEIGHING SYSTEM

DECAL P/N 215-010-00

When P/N 200-325-01 kit is installed, mounted adjacent to both the power switch and the circuit breaker in full view of the pilot.

TURN THE WEIGHING SYSTEM OFF WHEN NAVIGATION EQUIPMENT IN USE. NO AIRCRAFT OPERATION SHOULD BE PREDICATED ON THE READING OF THE ONBOARD WEIGHING SYSTEM.

(DECAL P/N 215-012-00)

When P/N 200-325-01 kit is installed, mounted adjacent to the load weigh indicator in view of the pilot.



RFM Supplement

Robinson R44

Document Number

121-051-00

Rev. 3

Page
8 of 24

FAA Approved

OCT 24 2016

SECTION 3 NORMAL PROCEDURES

STATIC DISCHARGE

Prior to attaching an external load, instruct the ground crew to ensure that the helicopter has been electrically grounded to discharge static electricity. If possible, maintain ground contact until hook up is completed.

PRE-FLIGHT CHECK

Before a flight involving external load operations perform the following procedures.

1. Check all mounting fasteners to ensure that they are tight.
2. Check the electrical connector and harness for damage and security.
3. Check the external portion of the manual release cable for damage with close attention to the transition at the cargo hook for tearing or splitting or exposed inner wires.



Manual release cables are wearable items and must be replaced as condition requires. Broken or kinked conduit or sticky operation are cause for immediate replacement.

4. Check the cargo hook case for cracks and damage.
5. Check the cargo hook load beam for gouges and cracks.
6. Swing the cargo hook to its full extremes to verify that it does not reach the limit of the manual release cable and electrical release harness range of motion. The manual release cable and electrical release harness must not be the stops that prevent the cargo hook from moving freely in all directions.



RFM Supplement

Document Number

121-051-00

Rev. 3

Robinson R44

Page
9 of 24

FAA Approved

OCT 24 2016

PRE-FLIGHT CHECK continued

7. Cycle the electrical release system to ensure proper operation. Pull downward on the cargo hook load beam with approximately 10 lbs of force and press the CARGO RELEASE switch on the cyclic (ref. Figure 3.7). The load beam must open. Release the load beam and it should return to the closed and locked position.
8. If the optional co-pilot switch is installed on the outboard side of the co-pilot's seat (ref. Figure 3.8) repeat the previous step except use this switch.

NOTICE

The co-pilot switch is an optional installation which is intended primarily for external load training. If this switch is installed but rarely used, take precautions to protect the switch from being inadvertently contacted.

9. Cycle the manual release mechanism to ensure proper operation. Pull downward on the cargo hook load beam with approximately 10 lbs of force and pull upwards on the manual release T-handle located between the pilot and co-pilot seat upwards. The load beam must open. Release the load beam and it should return to the closed and locked position.
10. Check the operation of the keeper on the cargo hook. Push it upwards to the open position and release it. It should snap back to the closed position.



RFM Supplement

Robinson R44

Document Number

121-051-00

Rev. 3

Page

10 of 24

FAA Approved

OCT 24 2016

PRE-FLIGHT CHECK continued

If a P/N 200-325-01 Cargo Hook Suspension Kit with Load Weigh is installed, perform the following additional procedure.

1. Power on the C-39 Load Indicator. After a brief self-diagnostic routine is complete the indicator display should indicate “0” as shown below (with no load on the cargo hook):

Figure 3.3 C-39 Indicator Display

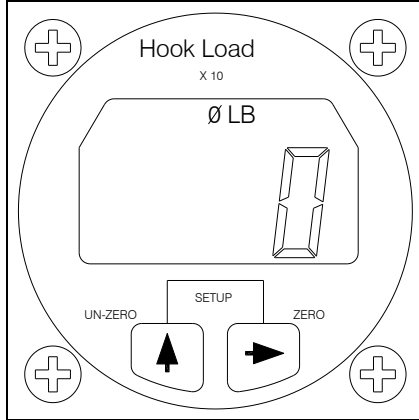

NOTICE

Refer to Owner's Manual 120-039-00 for setup instructions including changing the units, changing the calibration code, zeroing the display, changing the dampening level, etc.



RFM Supplement

Robinson R44

Document Number

121-051-00

Rev. 3

Page

11 of 24

FAA Approved

OCT 24 2016

PRE-FLIGHT CHECK continued

If the Remote Hook Electrical Release Kit is installed and the external load operation involves a remote hook, perform the following additional procedure.

1. Connect the electrical cable from the remote hook to the connector on the electrical cable suspended from the belly mounted connector. Press the “REMOTE HOOK” release switch on the cyclic and verify that the remote hook releases.

NOTICE

The remote hook is NOT included with the remote hook electrical release kit. Consult the remote hook manual for its operation instructions.

	RFM Supplement	Document Number 121-051-00	Rev. 3
	Robinson R44	Page 12 of 24	FAA Approved OCT 24 2016

Cargo Hook Rigging

Extreme care must be exercised in rigging a load to the Cargo Hook. If the load ring is too big it may work its way around the end of the load beam and be supported for a time on the keeper and then fall free. If the load ring is too small it may jam itself against the load beam during an attempted release. The following illustrations show recommended configurations and potential difficulties that must be avoided.



The examples shown are not intended to represent all problem possibilities. It is the responsibility of the operator to ensure the hook will function properly with the rigging.



RFM Supplement

Document Number

121-051-00

Rev. 3

Robinson R44

Page
13 of 24

FAA Approved

OCT 24 2016

Figure 3.2 Examples of Correct and Incorrect Cargo Hook Rigging

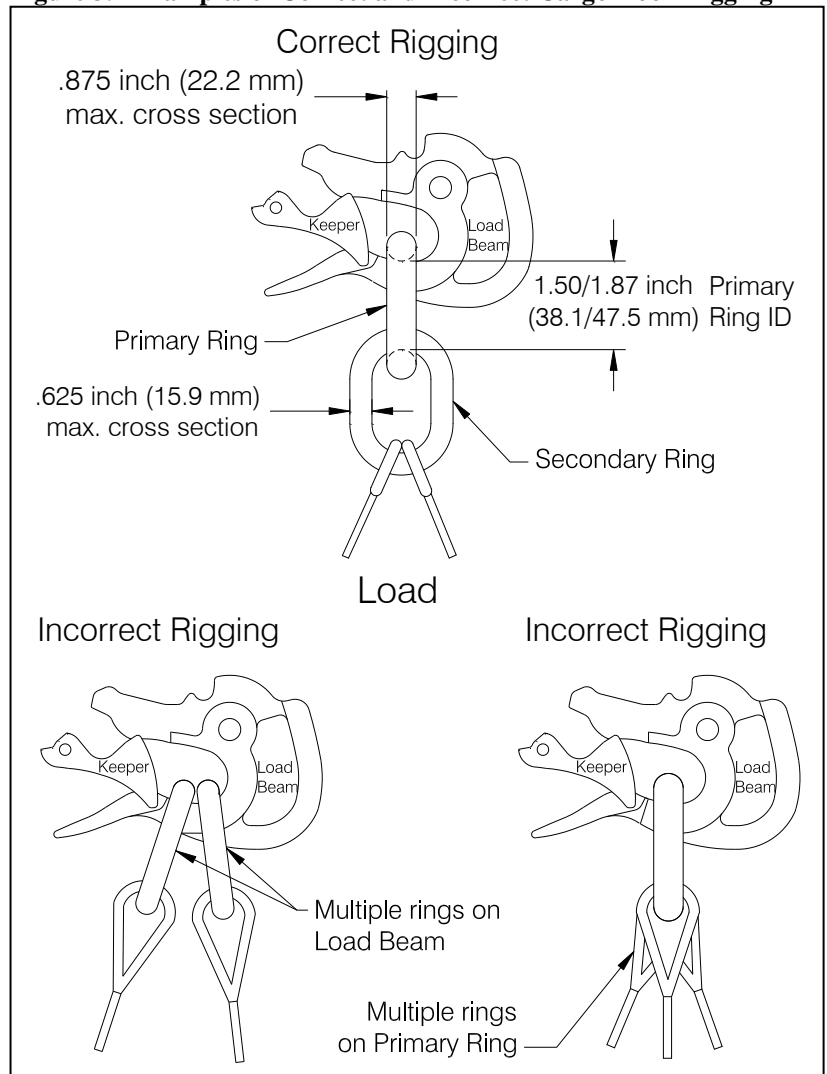

RFM Supplement

Robinson R44

Document Number

121-051-00

Rev. 3

Page

14 of 24

FAA Approved

OCT 24 2016

Cargo Hook Rigging continued

Un-Commanded Release Due to Too Large of a Load Ring



Load rings that are too large will cause an un-commanded release. The ring will flip over the end of the load beam and flip the keeper up and then fall free. Only correctly sized load rings must be used.

Figure 3.3 Un-commanded Release Due to Load Rings That Are Too Large

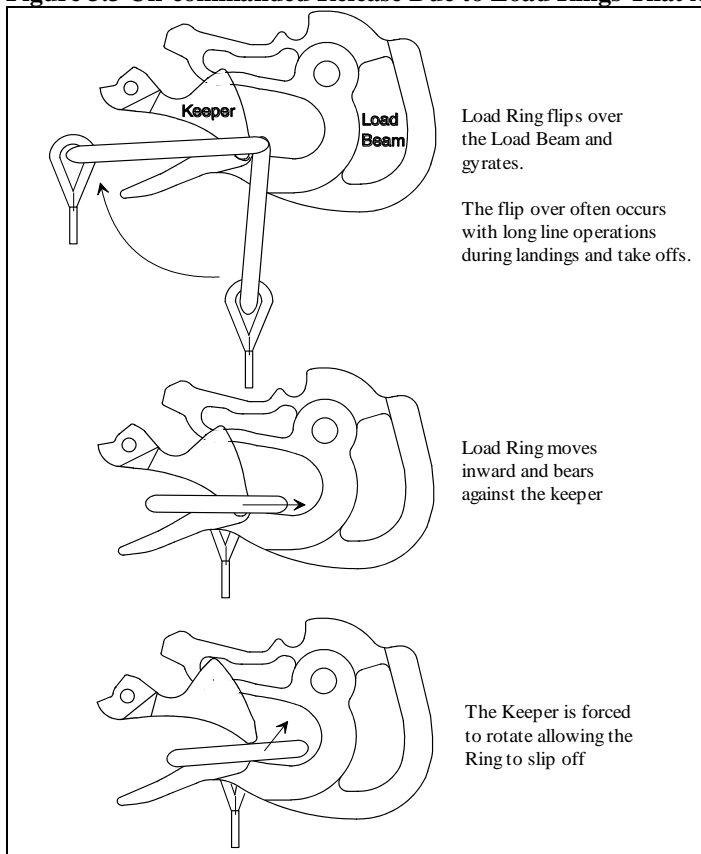

Cargo Hook Rigging continued

Load Hang-Up Due to Too Small of a Load Ring or Multiple Load Rings



Load rings that are too small or multiple load rings will hang on the load beam when the load is released. Only correctly sized load rings must be used.

Figure 3.4 Load Hang-up Due to Load Rings That Are Too Small or Using Multiple Load Rings

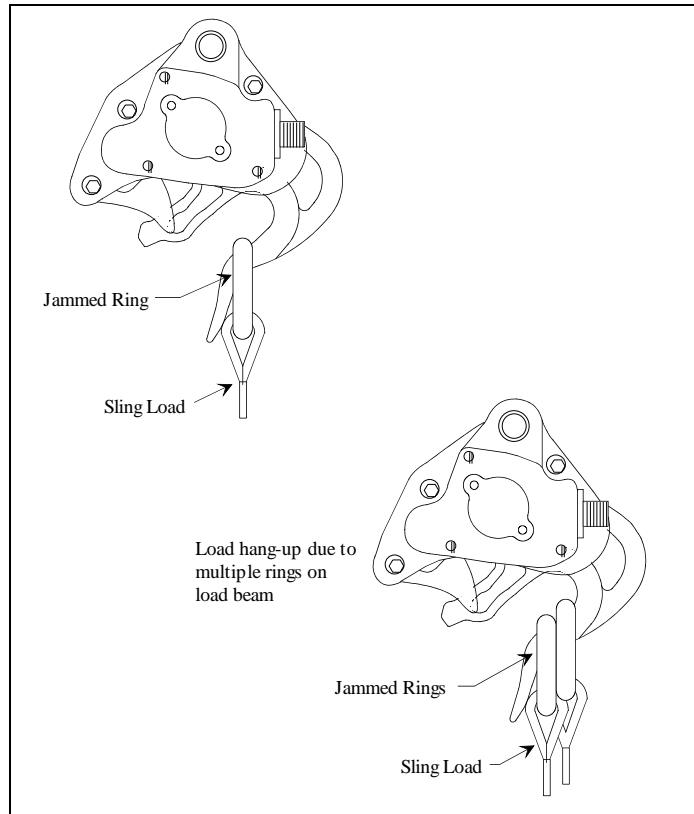

Cargo Hook Rigging continued

Un-Commanded Release Due to Nylon Type Straps



Nylon type straps (or similar material) must not be used directly on the cargo hook load beam as they have a tendency to creep under the keeper and fall free. If nylon straps must be used they should first be attached to a correctly sized primary ring. Only the primary ring should be in contact with the cargo hook load beam.

Figure 3.5 Un-commanded release due to nylon type straps

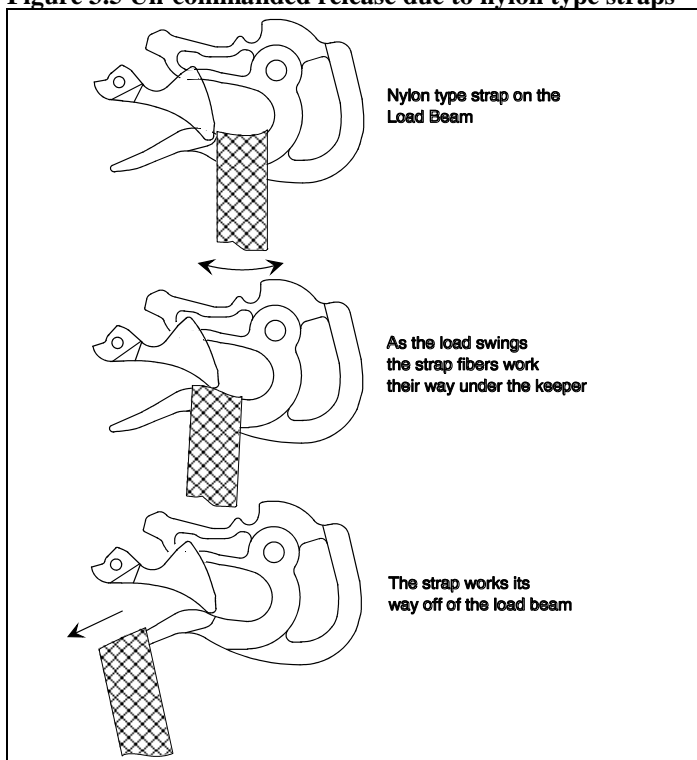

Cargo Hook Rigging continued

Un-Commanded Release Due to Cable or Rope Type Straps

! WARNING

Cable or rope type straps must not be used directly on the cargo hook load beam. Their braided eyes will work around the end of the load beam and fall free. If cable or rope is used they should first be attached to a correctly sized primary ring. Only the primary ring should be in contact with the cargo hook load beam.

Figure 3.6 Un-commanded release due to cable or rope straps

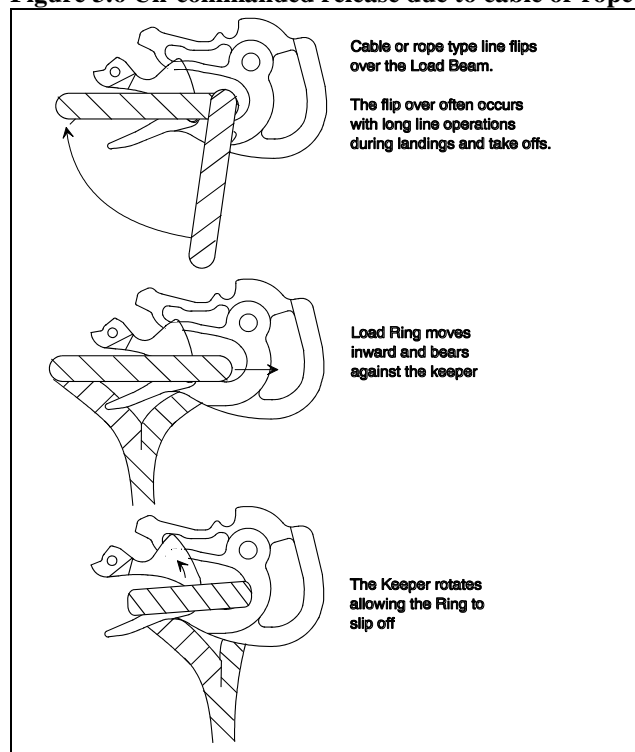

RFM Supplement

Robinson R44

Document Number

121-051-00

Rev. 3

Page
18 of 24

FAA Approved

OCT 24 2016

IN-FLIGHT OPERATION

Take-off

1. Following attachment of the external load, slowly increase the collective pitch and ascend vertically, maintaining the rotorcraft directly above the load. When the slack in the long line is removed dwell briefly before lifting the load from the surface.
2. Check torque required to hover with the external load.
3. Check for adequate directional control.
4. Take off into the wind, if possible, and ensure clearance of the external load over obstacles.

NOTICE

It is the responsibility of the operator to establish safe operational limits for each specific configuration.

⚠ CAUTION

Control movements should be made gently and kept to a minimum to prevent oscillation of the load and to maintain the external load angle within the limits of rotation of the cargo hook.



RFM Supplement

Robinson R44

Document Number

121-051-00

Rev. 3

Page

19 of 24

FAA Approved

OCT 24 2016

IN-FLIGHT OPERATION continued

Approach with and release of external load

1. Perform the approach at minimum rate of descent.
2. Execute the approach to hover with sufficient height to prevent the load from hitting obstacles on or being dragged along the ground and then slowly descend vertically to set the load on the ground.
3. Press the CARGO RELEASE switch (see Figure 3.7) on the cyclic or the optional switch on the outboard copilot's seat support (see Figure 3.8) to release the external load from the cargo hook.

The manual release T-handle (see Figure 3.9) is intended as a backup release in the event of an inability to release the load electrically but may be used to release the external load in normal circumstances.

If the optional remote hook release switch kit (kit P/N 200-396-00) is installed, a second switch is installed on the right-hand cyclic grip (see Figure 3.10). The external load may be released from the remote hook with this switch if it is installed.



A release of the external load from the remote hook with the load suspended above the ground can result in potentially dangerous re-coil of the long line. Consult the user's manual provided by the long line manufacturer for its characteristics, proper use, care and inspection.



RFM Supplement

Robinson R44

Document Number

121-051-00

Rev. 3

Page

20 of 24

FAA Approved

OCT 24 2016

IN-FLIGHT OPERATION continued

Approach with and release of external load continued

4. Visually check to ensure that the external load has been released.



Verify that the external load and long line has dropped free from the rotorcraft before departing the drop-site.



RFM Supplement

Document Number

121-051-00

Rev. 3

Robinson R44

Page
21 of 24

FAA Approved

OCT 24 2016

IN-FLIGHT OPERATION continued

Figure 3.7 Cyclic Grip Release Switch

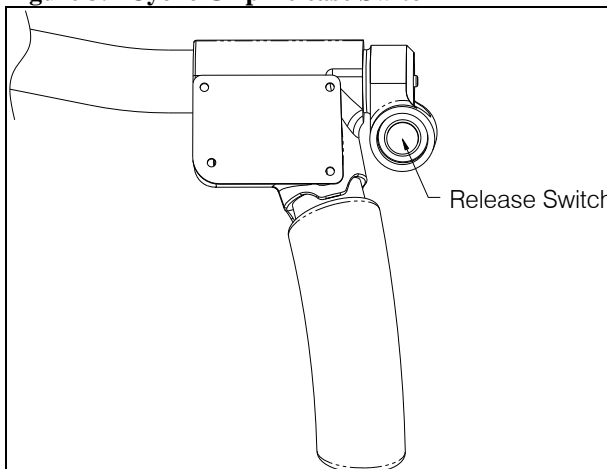
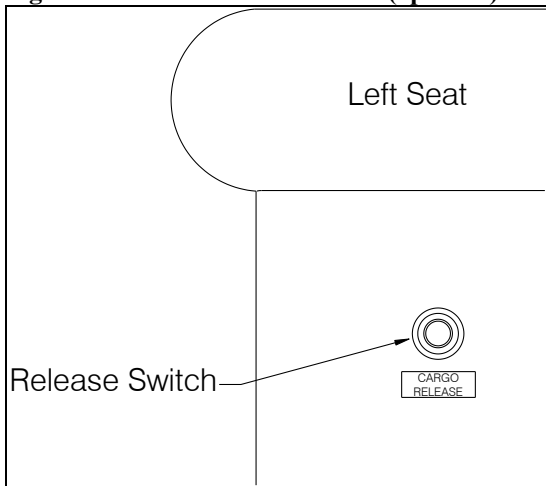

Figure 3.8 Co-Pilot's Seat Switch (optional)



RFM Supplement

Robinson R44

Document Number
121-051-00

Rev. 3

Page
22 of 24

FAA Approved

OCT 24 2016

IN-FLIGHT OPERATION continued

Figure 3.9 Manual Release Handle

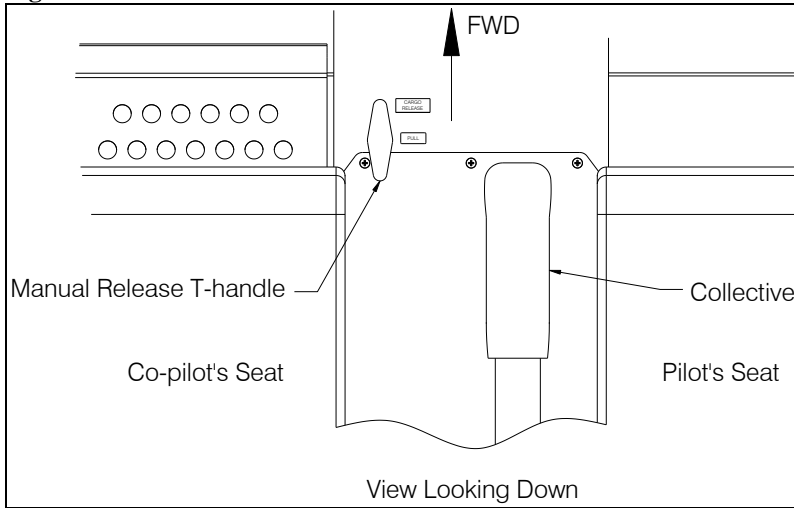
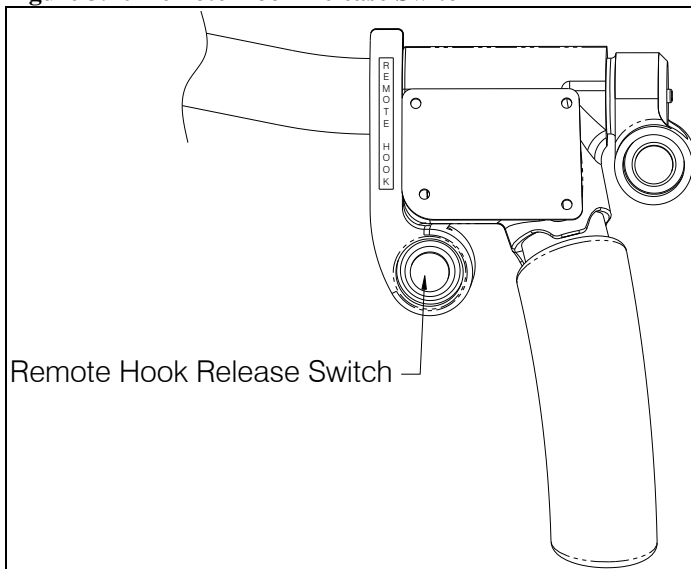

Figure 3.10 Remote Hook Release Switch



SECTION 4 EMERGENCY PROCEDURES

Cargo Fails to Release Electrically

In the event that the Cargo Hook will not release the external load electrically, proceed as follows:

1. Maintain tension on the sling.
2. Pull the manual release T-handle upwards to release the external load.

SECTION 5 PERFORMANCE

The basic Flight Manual issued by Robinson remains applicable.

There is no change from basic flight performance with no load attached to the Cargo Hook. Performance will be reduced depending on the size, weight and shape of the external load.

The Load Weigh System is designed and installed as a means of MONITORING the load (weight) suspended from the Cargo Hook. Functional and performance characteristics have not been determined on the basis of Load Cell indication or display. Therefore, this instrument shall NOT be used as a primary indication of performance and flight operation must NOT be predicated on its use.

	RFM Supplement	Document Number 121-051-00	Rev. 3
	Robinson R44	Page 24 of 24	FAA Approved OCT 24 2016