

PLEASE CHECK WEB SITE AT WWW.ONBOARDSYSTEMS.COM FOR THE LATEST REVISION OF THIS MANUAL

**FAA APPROVED
ROTORCRAFT FLIGHT MANUAL
SUPPLEMENT**

**Onboard Systems
Cargo Hook Suspension System
for the
Robinson R66**

STC SR02447SE

R/N _____ S/N _____

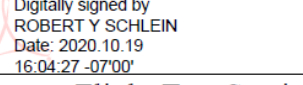
FAA Approved:  For 
Manager, Northwest Flight Test Section, AIR-715
Federal Aviation Administration
Seattle, WA

Date: 19 October 2020

	RFM Supplement	Document Number 121-058-00	
	Cargo Hook	Page 1 of 24	Rev. 2

Record of Revisions

Rev.	Date	Page(s)	Reason for Revision
0	07/20/15	All	Initial Release
1	05/25/17	All	Added kit P/Ns 200-380-10 and 200-381-10 which include cargo hook P/N 528-029-02 with Surefire Release. Added warning regarding longline re-coil.
2	19 October 2020	All	Added C-40 Indicator. Moved warning regarding external load angles from Section 2 to Section 4.



RFM Supplement

Document Number
121-058-00

Rev. 2

Cargo Hook

Page
2 of 24

FAA Approved
19 October 2020

SECTION 1

GENERAL

Introduction

This supplement must be attached to the appropriate FAA approved Rotorcraft Flight Manual when an Onboard Systems P/N 200-380-00, 200-380-10, 200-381-00, 200-381-01, 200-381-10, or 200-381-11 Cargo Hook Suspension Kit is installed in accordance with Supplemental Type Certificate (STC) NO. SR02447SE. The information contained herein supplements or supersedes the basic manual only in those areas listed herein. For limitations, procedures and performance information not contained in this supplement, consult the basic Rotorcraft Flight Manual.

System Description

The cargo hook suspension kit provides a means to transport jettisonable external loads. The kit includes the cargo hook, a structural linkage assembly (referred to as suspension assembly) which connects the cargo hook to the existing hard point on the belly of the helicopter (see Figure 1.1 for overview), and the cargo hook's primary and backup quick release systems for jettisoning of the external load.

In addition to the basic cargo hook suspension kit (P/N 200-380 series), a second kit configuration (P/N 200-381 series) includes a load weigh system. The load weigh system includes a load cell above the cargo hook which serves as part of the structural linkage, a load weigh indicator and an internal electrical wiring harness. This system provides the pilot with an indication of the weight of the load being carried on the cargo hook.

Kit P/Ns 200-380-10, 200-381-10, and 200-381-11 are the same as 200-380-00, 200-381-00, and 200-381-01 respectively except they include a cargo hook (P/N 528-029-02) with a delay circuit to help protect against inadvertent load release as a result of accidental contact with the Cargo Release switch or inadvertently pressing this switch. This delay circuit requires that the release switch be held for approximately ½ second in order to release the cargo hook load. This feature is referred to as Surefire Release.

	RFM Supplement	Document Number 121-058-00	Rev. 2
	Cargo Hook	Page 3 of 24	FAA Approved 19 October 2020

System Description continued

Figure 1.1 – Cargo Hook Installation Overview

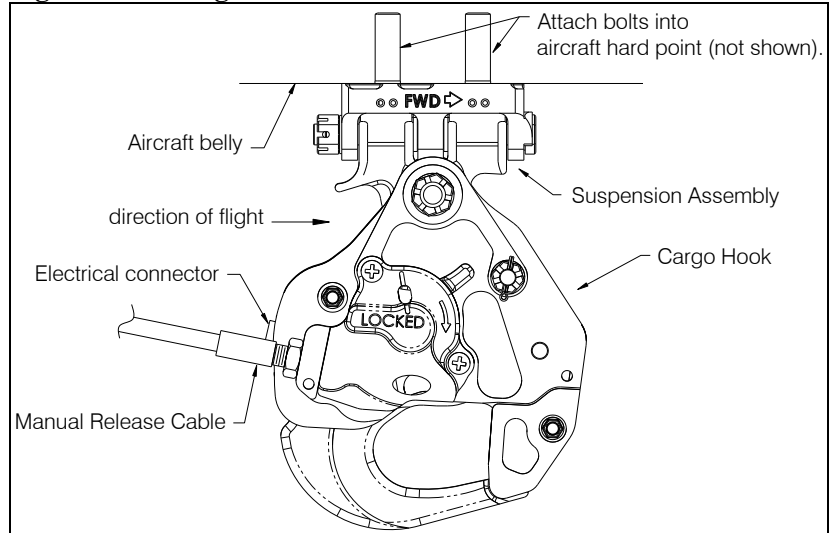

The cargo hook's primary quick release system is operated by a push-button electrical release switch on the end of the pilot's cyclic grip assembly (see Figure 1.2). Pressing the switch releases the load on the cargo hook.

Figure 1.2 – Cargo Release Switch

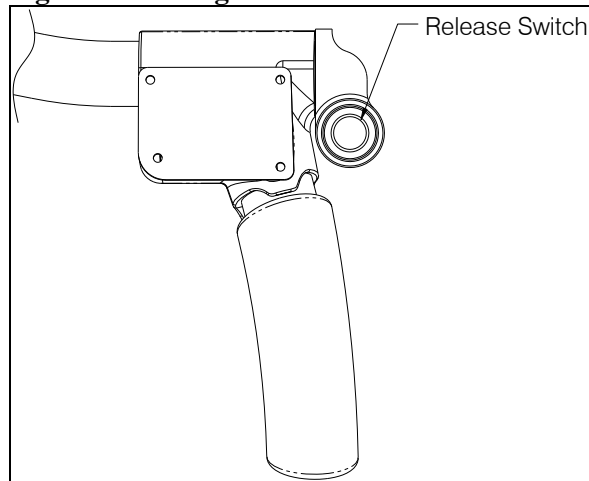

RFM Supplement

Cargo Hook

Document Number
121-058-00

Rev. 2

Page
4 of 24

FAA Approved
19 October 2020

System Description continued

The cargo hook's backup quick release system consists of a manual release cable routed from the cargo hook to a T-handle mounted between the pilot and co-pilot seats (see Figure 1.3). Pulling up on the T-handle releases the load on the cargo hook.

Figure 1.3 T-handle Location

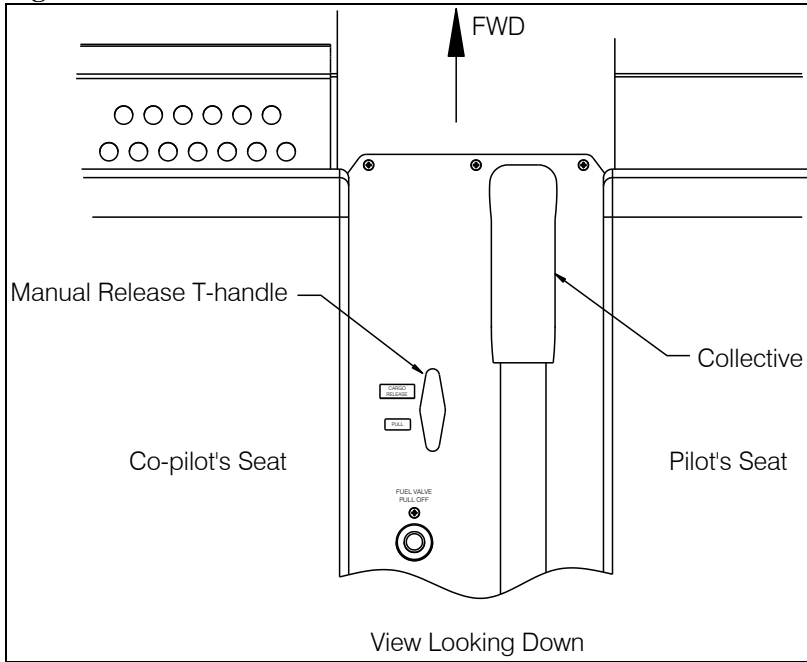

RFM Supplement

Document Number
121-058-00

Rev. 2

Cargo Hook

Page
5 of 24

FAA Approved
19 October 2020

System Description continued

Either of the base kit configurations may be complemented by a remote hook release kit (P/N 200-392-00) and/or a co-pilot release switch kit (P/N 200-417-00). The remote hook release kit provides the fixed electrical provisions including a release switch on the cyclic grip (see Figure 1.4) for the release of a load from a remote cargo hook at the end of a long line.

Figure 1.4 Remote Hook Release Switch (optional)

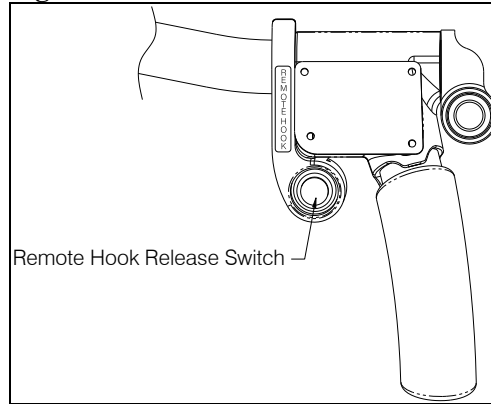

The co-pilot release switch kit provides an additional cargo release switch for the belly mounted cargo hook. This switch is mounted on the co-pilot's cyclic grip. The external load may also be released with this switch if it is installed.

Figure 1.5 Co-Pilot Release Switch (optional)

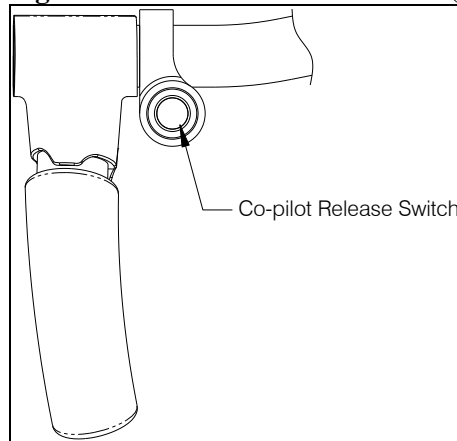

RFM Supplement

Cargo Hook

Document Number
121-058-00

Rev. 2

Page
6 of 24

FAA Approved
19 October 2020

SECTION 2 LIMITATIONS

Airspeed Limits

V_{ne}= 80 KIAS, or less with external load. Do not exceed V_{ne} of basic helicopter.



Maximum operational air speed with external loads is dependent upon the load configuration and sling length. It is the operator's responsibility to establish the maximum operational speed for each specific configuration.

Weight Limits

The maximum Cargo Hook load is 1015 lbs (460 kgs). Consult the basic Rotorcraft Flight Manual for weight limits for the rotorcraft.

Center of Gravity Limits

Center of gravity limits must be checked with and without the external load to verify that the rotorcraft is within the approved center of gravity limits.

Kinds of Operation Limitation

The basic Flight Manual remains applicable. With a load attached to the cargo hook, operation shall be conducted in accordance with the respective national operational requirements.

These cargo hook kits (as installed per the STC) do not meet the 14 CFR part 27 certification requirements for Human External Cargo (HEC).



The cargo hook equipment certification approval does not constitute operational approval; operational approval for external load operations must be granted by the local Aviation Authority.



RFM Supplement

Document Number
121-058-00

Rev. 2

Cargo Hook

Page
7 of 24

FAA Approved
19 October 2020

Placards

 <b style="font-size: 1.2em;">WARNING
EXTERNAL LOAD LIMIT 1015 LB (460 KG)
<small>215-277-00</small>

Mounted on the belly of the aircraft adjacent to the cargo hook attachment point in clear view of the ground support personnel.

FOR FAR PART 133.35(A) OPERATIONS:
 NO PERSON MAY BE CARRIED UNLESS HE IS:
 (1) A FLIGHT CREW MEMBER OR TRAINEE;
 (2) PERFORMS AN ESSENTIAL FUNCTION IN CONNECTION WITH THE EXTERNAL LOAD OPERATION; OR
 (3) IS NECESSARY TO ACCOMPLISH THE WORK ACTIVITY DIRECTLY ASSOCIATED WITH THAT OPERATION.

Mounted on the instrument panel in clear view of the pilot.

CARGO RELEASE	Mounted adjacent to the cyclic release switch in clear view of the pilot.
CARGO RELEASE	Mounted adjacent to the co-pilot's release switch (if the co-pilot release switch is installed).
CARGO RELEASE	Mounted adjacent to the mechanical release in clear view of the pilot.
PULL	Mounted adjacent to the manual release T-handle in clear view of the pilot.
CARGO HOOK	Mounted adjacent to the Cargo Hook circuit breaker in clear view of the pilot.

Placards continued

R E M O T E H O O K	<p>Mounted on the remote hook release switch housing (if remote hook release kit is installed).</p>
REMOTE HOOK	<p>Mounted adjacent to the Remote Hook circuit breaker in clear view of the pilot.</p>
<div style="border: 1px solid black; background-color: black; color: white; padding: 5px; display: inline-block;"> CARGO RELEASE: HOLD FOR > 1 SECOND </div> <p>Adhered adjacent to the cockpit cargo release switch if optional Cargo Hook with Surefire Release P/N 528-029-02 is installed.</p>	
<div style="display: flex; align-items: center; justify-content: center;"> <div style="border: 1px solid black; background-color: black; color: white; padding: 5px; display: flex; flex-direction: column; align-items: center;"> <div style="background-color: blue; color: white; padding: 2px 10px;">NOTICE</div> <div style="font-size: small; padding: 2px 10px;">Electrical release delayed ½ second to avoid inadvertent actuation.</div> </div> <div style="margin: 0 10px;">  </div> </div> <p>Adhered on the solenoid housing of optional cargo hook P/N 528-029-02 which is equipped with Surefire Release.</p>	
<div style="border: 1px solid black; padding: 5px; display: inline-block;"> <p style="font-size: small; margin: 0;">TURN THE WEIGHING SYSTEM OFF WHEN NAVIGATION EQUIPMENT IN USE. NO AIRCRAFT OPERATION SHOULD BE PREDICATED ON THE READING OF THE ONBOARD WEIGHING SYSTEM.</p> </div> <p>When a 200-381 series kit with the C-39 indicator is installed, mounted adjacent to the load weigh indicator in view of the pilot. This placard is not applicable to the C-40 indicator (P/N 210-293-00).</p>	

SECTION 3 EMERGENCY PROCEDURES

Cargo Hook Fails to Release Electrically

In the event that the Cargo Hook will not release the external load electrically, proceed as follows:

1. Maintain tension on the sling.
2. Pull up on the manual release T-handle between the pilot and co-pilot seats to release the external load.

	RFM Supplement	Document Number 121-058-00	Rev. 2
	Cargo Hook	Page 10 of 24	FAA Approved 19 October 2020

SECTION 4 NORMAL PROCEDURES

Pre-flight Check

Before a flight involving external load operations perform the following procedures. If the procedures are not successful do not use the equipment until the problem has been corrected.

1. Check all mounting fasteners to ensure that they are tight.
2. Check the external electrical connectors and harnesses for damage and security.
3. Check the external portion of the manual release cable for damage with close attention to the transition at the cargo hook for tearing or splitting or exposed inner wires.

Figure 4.1 Manual Release Cable Check

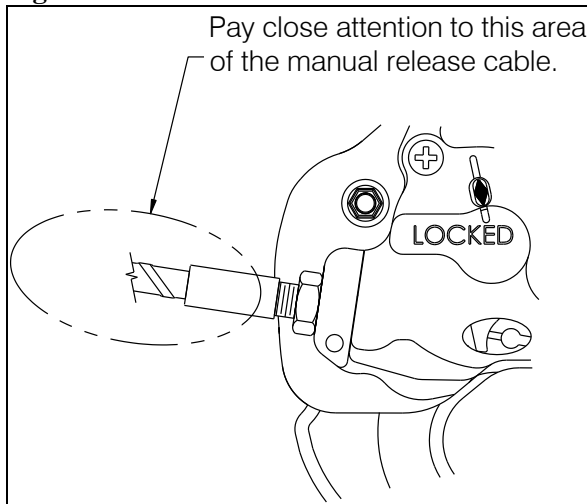

Pre-flight Check continued

4. Swing the cargo hook to its full extremes to verify that it does not reach the limit of the manual release cable and electrical release harness range of motion. The manual release cable and electrical release harness must not be the stops that prevent the cargo hook from moving freely in all directions.
5. Check the manual release cable rigging through the window in the cargo hook manual release cover. Rotate the manual release lever clockwise to remove the free play (the free play is taken up when the hook lock indicator begins to move, this is also readily felt as the lever rotates relatively easily for several degrees as the free play is taken up) and hold it in this position while checking the gap between the release lever fork and the cable ball end as shown below. Visually check that there is approximately a minimum gap of 1/8" (3.2 mm) as shown in Figure 4.2.

Figure 4.2 Manual Release Cable Rigging

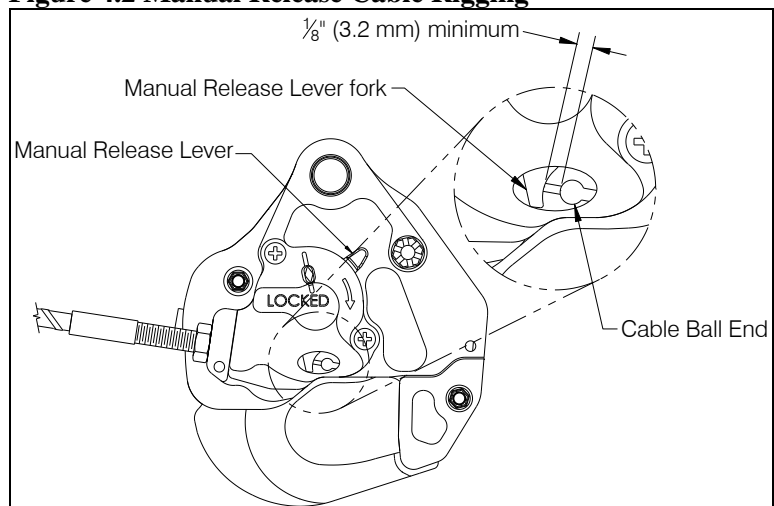

Pre-flight Check continued

6. Cycle the electrical release system to ensure proper operation. The following instructions are applicable to cargo hook P/N 528-029-00.

NOTICE

If Cargo Hook with Surefire Release (P/N 528-029-02) is installed, the electrical release includes a 1/2 second time delay. See specific procedures in this step for this cargo hook model.

- Press the CARGO RELEASE switch on the cyclic (ref. Figure 1.2) and the cargo hook should open with no load on it.
- Return the cargo hook to the closed and locked position by manually pushing up on the load beam. The load beam should snap shut.

The following instructions are applicable to the cargo hook P/N 528-029-02. This cargo hook can also be identified by its gold color solenoid cover (see Figure 4.3).

- *Very* briefly press the Cargo Release switch, the cargo hook should not actuate and the load beam should remain closed.
- Press and hold the Cargo Release switch for several seconds, the load beam should fall to the open position and the cargo hook solenoid should continue to cycle repeatedly.

	RFM Supplement	Document Number 121-058-00	Rev. 2
	Cargo Hook	Page 13 of 24	FAA Approved 19 October 2020

Pre-flight Check continued

NOTICE

By design (to help protect against inadvertent load release) cargo hook P/N 528-029-02 requires that the switch on the cyclic be held for at least 1/2 second to release the load.

Figure 4.3 Surefire Configuration Identification

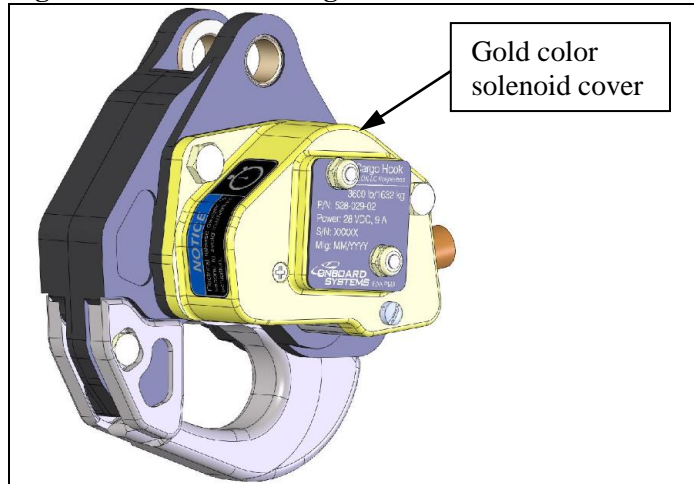

RFM Supplement

Cargo Hook

Document Number
121-058-00

Rev. 2

Page
14 of 24

FAA Approved
19 October 2020

Pre-flight Check continued

7. Cycle the cargo hook's manual release system to ensure proper operation. Pull up on the manual release handle in the cockpit. The cargo hook load beam should open. Return the cargo hook load beam to the locked position by manually pushing up on the load beam. The load beam should snap shut. Verify that the hook lock indicator on the side of the hook returns to the fully locked position.



In the fully locked position the hook lock indicator must align with the lines on the manual release cover (see Figure 4.4).

Figure 4.4 Hook Lock Indicator

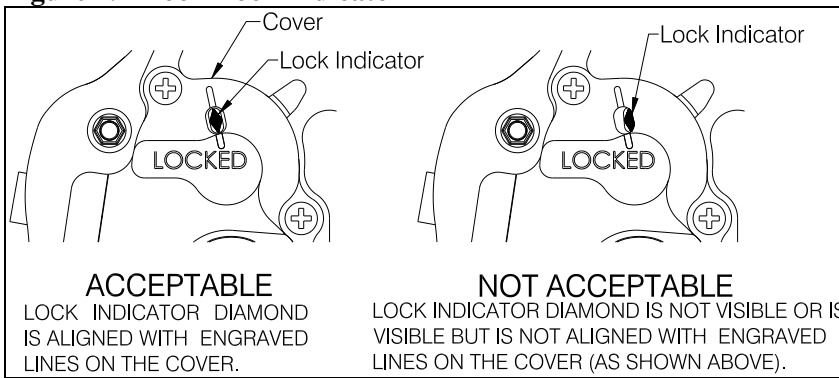

RFM Supplement

Document Number
121-058-00

Rev. 2

Cargo Hook

Page
15 of 24

FAA Approved
19 October 2020

Pre-flight Check continued

8. If a remote hook release kit (P/N 200-392-00) is installed and a remote cargo hook is connected to it, press the REMOTE HOOK release switch on the cyclic (reference Figure 1.4 for location). The remote cargo hook's load beam should open (a remote cargo hook is not included with the kits listed herein; refer to applicable remote cargo hook manual for operation).

If the load weigh system is installed, procedures vary depending on the model of indicator installed, refer to the following.

9. Power on the Load Indicator. For the C-39 Indicator after a brief self-diagnostic routine is complete the indicator display should indicate "0" as shown below (with no load on the cargo hook):

Figure 4.5 C-39 Indicator

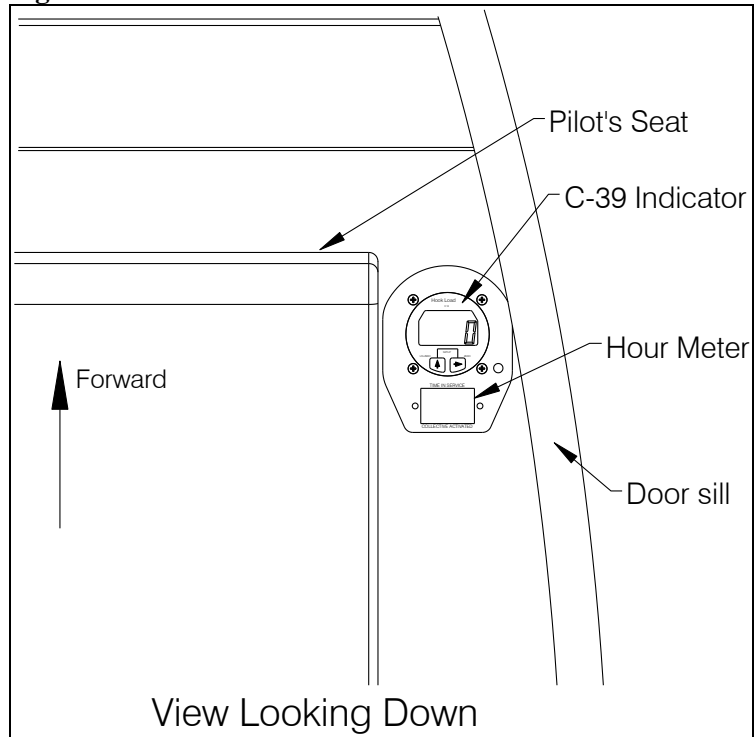

RFM Supplement

Cargo Hook

Document Number
121-058-00

Rev. 2

Page
16 of 24

FAA Approved
19 October 2020

Pre-Flight Check continued

NOTICE

For the C-39 model refer to Owner's Manual 120-039-00 for setup instructions including changing the units, changing the calibration code, zeroing the display, changing the dampening level, etc.

For the C-40 model, on power up an Information screen will display the Hook Hours, software version, and serial number (S/N) and then the indicator should display the Load screen. The Load screen of the C-40 model is shown below.

Figure 4.6 C-40 Indicator - Load Screen Shown

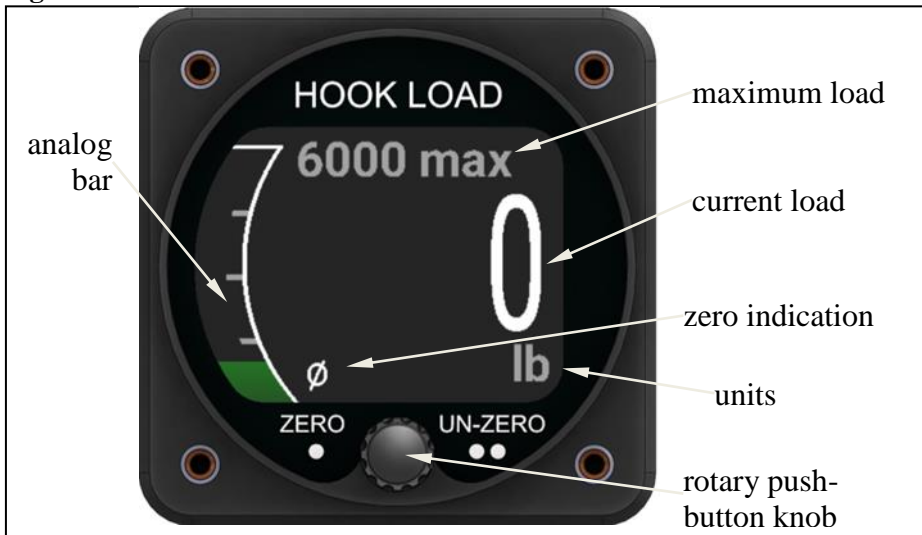

Pre-Flight Check continued

NOTICE

For the C-40 model refer to Owner's Manual 120-152-00 for detailed setup instructions including changing the units, changing the brightness of the display, etc. and additional operation instructions.

The C-40 model includes a Maximum Load setting, this setting provides the option to select a maximum load for each flight involving external load operations based on flight conditions (temperature, altitude, fuel, etc.) or it can be set to the maximum external load rating for the helicopter. To set the maximum load:

- From the Load screen press and hold the rotary push button knob until the Maximum Load screen appears.

Figure 4.7 Maximum Load Screen



- Rotate the knob to the left or right to decrease or increase the value to the desired setting.
- Press the knob to set this value.

Pre-Flight Check continued

To zero (or tare) the weight of the long line, net, remote hook, etc. from the displayed load, apply that weight to the cargo hook and press the knob once and the display should zero out. Press the knob twice to un-zero (un-tare) the display and add this weight back in.

NOTICE

The analog bar always displays the un-zeroed load. If there is a discrepancy between the analog bar and the displayed load, a large amount of load has likely been zeroed.

	RFM Supplement	Document Number 121-058-00	Rev. 2
	Cargo Hook	Page 19 of 24	FAA Approved 19 October 2020

Static Discharge

Prior to attaching an external load, instruct the ground crew to ensure that the helicopter has been electrically grounded to discharge static electricity. If possible, maintain ground contact until hook up is completed.

Cargo Hook Rigging

Extreme care must be exercised in rigging a load to the Cargo Hook. Figure 4.8 shows the recommended rigging configuration and configurations to avoid. The examples shown are not intended to represent all possibilities.



It is the responsibility of the operator to ensure the cargo hook will function properly with the rigging.



Multiple load rings, nylon type straps (or similar material) or rope must not be used directly on the cargo hook load beam. If nylon straps or rope must be used they should be first attached to a steel primary ring. Verify that the ring will freely slide off the load beam when it is opened. Only the primary ring should be in contact with the cargo hook load beam. See Figure 4.8.



RFM Supplement

Document Number
121-058-00

Rev. 2

Cargo Hook

Page
20 of 24

FAA Approved
19 October 2020

Cargo Hook Rigging continued

Figure 4.8 Cargo Hook Load Rigging Examples

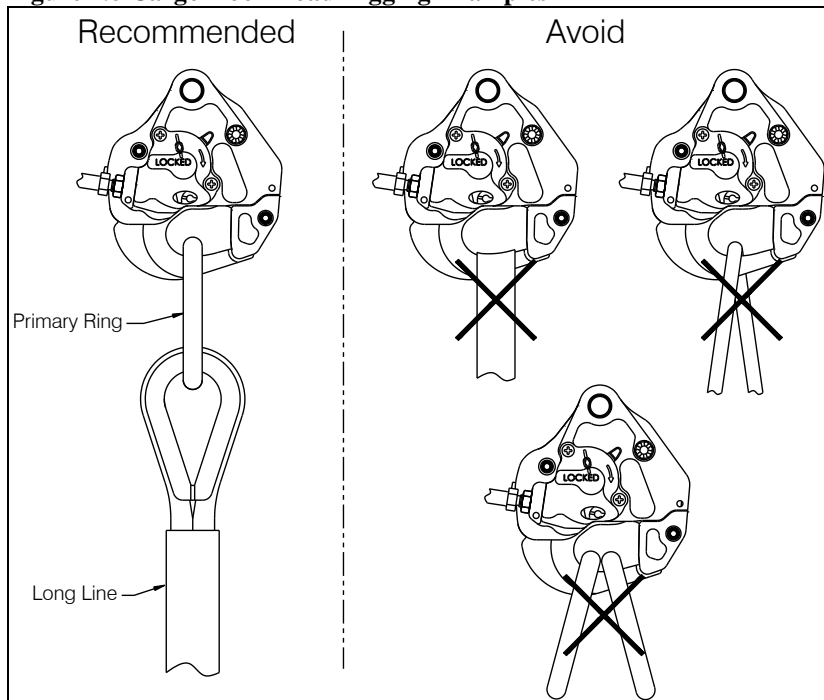

RFM Supplement

Document Number
121-058-00

Rev. 2

Cargo Hook

Page
21 of 24

FAA Approved
19 October 2020

Take-off

1. Following attachment of the external load, slowly increase the collective pitch and ascend vertically, maintaining the rotorcraft directly above the load. When the slack in the long line is removed dwell briefly before lifting the load from the surface.
2. Check torque required to hover with the external load.
3. Check for adequate directional control.
4. Take off into the wind, if possible, and ensure clearance of the external load over obstacles.

NOTICE

It is the responsibility of the operator to establish safe operational limits for each specific configuration.

NOTICE

Control movement should be made smoothly and kept to a minimum to prevent oscillation of the load.

! WARNING

The suspension assembly is designed to allow the cargo hook to pivot and align with the external load in all directions with limits to protect the electrical and mechanical release cables from damage. Take precautions to prevent external load angles which exceed the limits of rotation provided by the suspension as the load may not be releasable in this position.



RFM Supplement

Document Number
121-058-00

Rev. 2

Cargo Hook

Page
22 of 24

FAA Approved
19 October 2020

Approach With and Release of External Load

1. Perform the approach at minimum rate of descent.
2. Execute the approach to hover with sufficient height to prevent the load from hitting obstacles on or being dragged along the ground and then slowly descend vertically to set the load on the ground.
3. Press the CARGO RELEASE switch (see Figure 1.2) on the cyclic to release the external load from the cargo hook.

The manual release T-handle (see Figure 1.3) is intended as a backup release in the event of an inability to release the load electrically but may be used to release the external load in normal circumstances.

If the optional co-pilot release switch kit (kit P/N 200-417-00) is installed, a second switch is installed on the left-hand cyclic grip (see Figure 1.5). The external load may also be released by a co-pilot with this switch if it is installed.



A release of the external load from the remote hook with the load suspended above the ground can result in potentially dangerous re-coil of the long line. Consult the user's manual provided by the long line manufacturer for its characteristics, proper use, care and inspection.

4. Visually check to ensure that the external load has been released.

	RFM Supplement	Document Number 121-058-00	Rev. 2
	Cargo Hook	Page 23 of 24	FAA Approved 19 October 2020

SECTION 5 PERFORMANCE

General

There is no change from basic flight performance with no load attached to the Cargo Hook.

The Load Weigh System is intended as a means of MONITORING the weight of the load suspended from the Cargo Hook.

Before lifting a load, it is recommended that the load weight be estimated, the shape/size is considered and, upon lifting the load, monitor the load indicator and compare the actual engine torque value vs. the expected value for a given weight to verify sufficient performance.

	RFM Supplement	Document Number 121-058-00	Rev. 2
	Cargo Hook	Page 24 of 24	FAA Approved 19 October 2020