	Rotorcraft Flight Manual Supplement	Document Number 121-073-00
	Cargo Swing Suspension	Revision 1

ROTORCRAFT FLIGHT MANUAL SUPPLEMENT

Cargo Swing Suspension System on the Airbus Helicopters' AS350B3 Rotorcraft

STC SR01164SE

R/N _____ S/N _____

FAA Approved:  For Digitally signed by
ROBERT Y SCHLEIN
Date: 2021.08.23
10:01:28 -07'00'

Manager, Northwest Flight Test Section, AIR-715
Federal Aviation Administration
Seattle, WA

Date: 23 Aug 2021

	Rotorcraft Flight Manual Supplement	Document Number 121-073-00
	Cargo Swing Suspension	Revision 1

Record of Revisions

Revision	Page(s)	Reason for Revision	FAA Approval
0	All	Initial Release	R. Schlein 24 June 2021
1	4, 5, 8, 11, 17	Clarifications and edits to wording. Updated rigging instructions.	 For 23 Aug 2021 <small>Digitally signed by ROBERT Y SCHLEIN Date: 2021.08.23 10:01:06 -07'00'</small>

Register Your Products for Automatic Notifications

Onboard Systems offers a free notification service via fax or email for product alerts and documentation updates. By registering your Onboard Systems products at our website, we will be able to contact you if a service bulletin is issued, or if the documentation is updated.

You can choose to receive notices on an immediate, weekly, or monthly schedule via fax, email or both methods. There is no charge for this service. Please visit our website at www.onboardsystems.com/notify.php to get started.

[Please check our web site www.onboardsystems.com](http://www.onboardsystems.com)
[for the latest revision of this manual.](#)

	Rotorcraft Flight Manual Supplement	Document Number 121-073-00
	Cargo Swing Suspension	Revision 1

Table of Contents

Part I, FAA Approved Pages

1.0 General Information	4
2.0 Limitations.....	5
3.0 Emergency Procedures.....	7
4.0 Normal Procedures	8
5.0 Performance	18

Part II, Manufacturer’s Data

6.0 Weight and Balance	19
7.0 System Description	19

	Rotorcraft Flight Manual Supplement	Document Number 121-073-00
	Cargo Swing Suspension	Revision 1

1.0 General Information

Attach this supplement to the appropriate FAA approved Rotorcraft Flight Manual when an Onboard Systems International Cargo Swing Suspension System P/N 200-280-07 or 200-280-08 or C-40 Indicator Upgrade Kit P/N 200-472-00 is installed in accordance with Supplemental Type Certificate (STC) SR01164SE (ref. Section 7.0 for descriptions of the system). The information contained herein supplements or supersedes the Rotorcraft Flight Manual only in those areas listed herein. For limitations, procedures, and performance information not contained in this supplement, consult the basic Flight Manual.

	Rotorcraft Flight Manual Supplement	Document Number 121-073-00
	Cargo Swing Suspension	Revision 1

2.0 Limitations

The limitations specified in the basic Flight Manual remain applicable and are complemented by the information contained in the section.

2.1 Weight Limitation

The maximum weight to be carried on the cargo hook is 3086 lbs. (1400 kg).

The maximum gross weight of the rotorcraft including the external load is 6173 lbs. (2800 kg).

Loads that result in gross weight above 4961 lbs. (2250 kg) must be jettisonable.

2.2 Longitudinal CG

With an external load, the longitudinal limits are defined according to the weight as per the graph below. The dashed line represents the longitudinal cg without external load.

Figure 2.2.1 Longitudinal CG with External Load

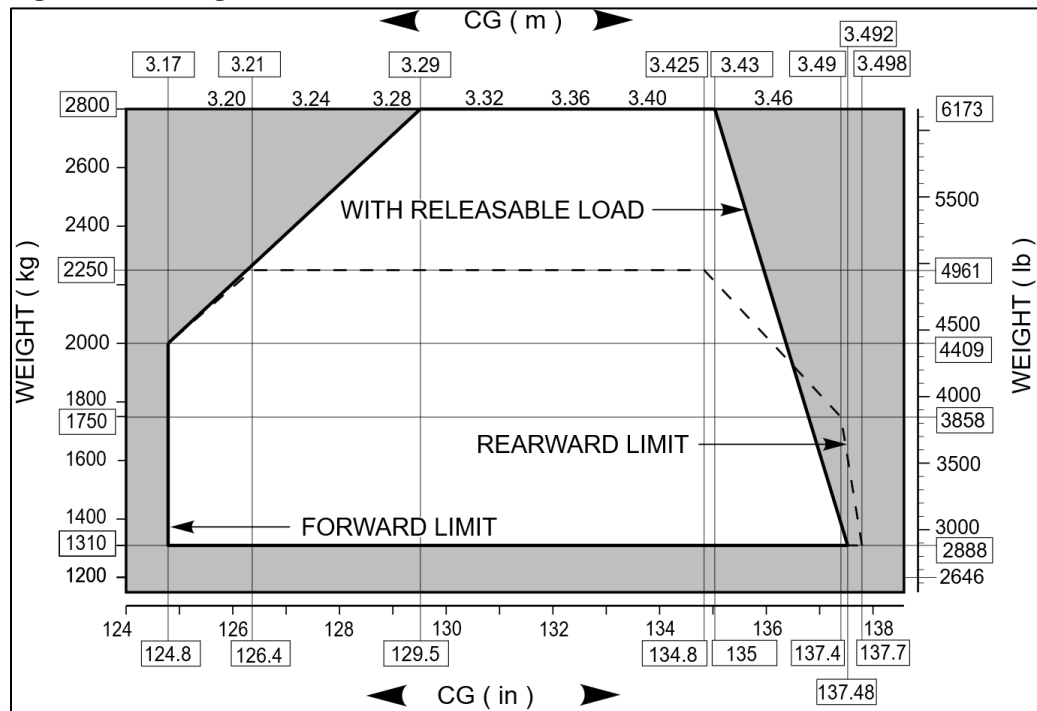

2.3 Airspeed Limitation

Vne with external load is 80 KIAS.

	Rotorcraft Flight Manual Supplement	Document Number 121-073-00
	Cargo Swing Suspension	Revision 1

2.4 Operating Limitation

With a load attached to the cargo hook, operation shall be conducted in accordance with the respective national operational requirements.

Cargo hook equipment certification approval does not constitute operational approval; operational approval for external load operations must be granted by the responsible authority in accordance with the applicable operational regulations.

The Cargo Swing System does not comply with the 14 CFR part 27 certification requirements for Human External Cargo (HEC).

The Cargo Swing System is approved for lifting external loads which are jettisonable and lifted free of land or water. Approval of operations in which the external load remains in contact with land, water, or fixed structure must be granted by the responsible authority in accordance with the applicable operational regulations.

2.5 Placards

The following placards are included with the Cargo Swing System.

- Adhered on the solenoid housing of optional cargo hook P/N 528-028-02 which is equipped with Surefire Release:



- Located near the cargo release switch on the cyclic if Cargo Hook P/N 528-028-02 (features Surefire Release) is installed.



- Located on the belly in view of ground personnel.

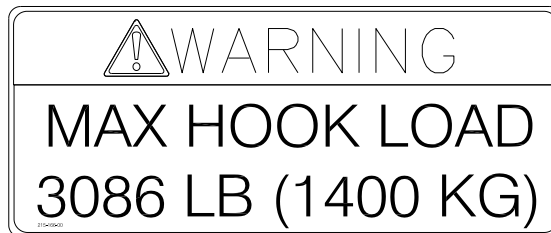

	Rotorcraft Flight Manual Supplement	Document Number 121-073-00
	Cargo Swing Suspension	Revision 1

3.0 Emergency Procedures



In an emergency such as snagged load or engine failure, the manual release system should be the first option for release of the external load as this system provides greater load release authority in an overload condition. If the manual release option fails, NEXT try the electrical release.

3.1 Engine failure with external load

3.1.1 In cruise flight

1. Establish auto-rotational flight
2. Release external load as soon as possible.

3.1.2 In hover

1. Reduce collective pitch according to height.
2. Release external load as soon as possible.

3.1.3 While ground crew is attaching the external load.

1. Move the rotorcraft to the right. Ground crew is to be instructed to move to the left of the rotorcraft.

3.2 Cargo hook fails to release electrically.

1. Pull the Cargo Release lever on the collective to release the external load.

	Rotorcraft Flight Manual Supplement	Document Number 121-073-00
	Cargo Swing Suspension	Revision 1

4.0 Normal Procedures

The normal procedures in the Rotorcraft Flight Manual issued by the type certificate holder are applicable and are complemented by the procedures in this section.

- Carrying heavy external loads is a delicate operation due to the possible effects of a swinging load on the flight behavior of the helicopter. Consequently, pilots are advised to train with gradually increasing external load weights before conducting operations with heavy or bulky loads.
- Perform operations with no or low load on a long line or in a net in such a way to ensure that the trailing line or net does not come close to the tail rotor.
- Prior to attaching an external load, instruct the ground crew to ensure that the helicopter has been electrically grounded to discharge static electricity. If possible, maintain ground contact until hook up is completed.
- For AS350B3 rotorcraft with Mod 07-4716 incorporated, the load weigh system with the C-40 model load indicator interfaces with the VEMD to set the N2 datum sent by the VEMD to the FADEC to 400 rpm when the measured external load on the cargo hook is 331 lbs (150 kg) or more. The N2 datum is independent of the collective pitch and yaw pedal position until the measured external load drops below 165 lbs (75 kg).

4.1 Pre-flight Check

Prior to a flight involving external load operations perform the following.

1. Visually check all cargo hook and swing suspension fasteners to ensure that they are secure.
2. Visually check the external electrical harnesses and hydraulic hose and their connections for damage and security.
3. Visually check the cargo hook and suspension components for damage.
4. Visually check for cracks in the suspension frame. The frame tubes contain a corrosion preventative compound which may leak out through a crack and also provide an indication of a crack.
5. Move the cargo hook and swing suspension in the fore/aft and side to side directions and verify all pivot points (including the upper pivot of the swing frame assembly) are freely rotating.
6. Cycle the electrical release system to ensure proper operation. The following instructions are applicable to cargo hook P/N 528-028-00.

	Rotorcraft Flight Manual Supplement	Document Number 121-073-00
	Cargo Swing Suspension	Revision 1

NOTICE

If Cargo Hook with Surefire Release (P/N 528-028-02) is installed, the electrical release includes a ½ second time delay. See specific procedures in this step for this cargo hook model.

- Press the Cargo Release switch on the cyclic, the load beam should fall to the open position with no load on it. Return the cargo hook to the closed and locked position by manually pushing up on the load beam. The load beam should snap shut.

NOTICE

The cargo swing system uses the TC electrical release switch located on the cyclic.

The following instructions are applicable to the optional cargo hook P/N 528-028-02. In addition to the P/N, this cargo hook can also be identified by its gold color solenoid cover (see Figure 4.1.1).

Figure 4.1.1 Cargo Hook w/ Surefire Identification

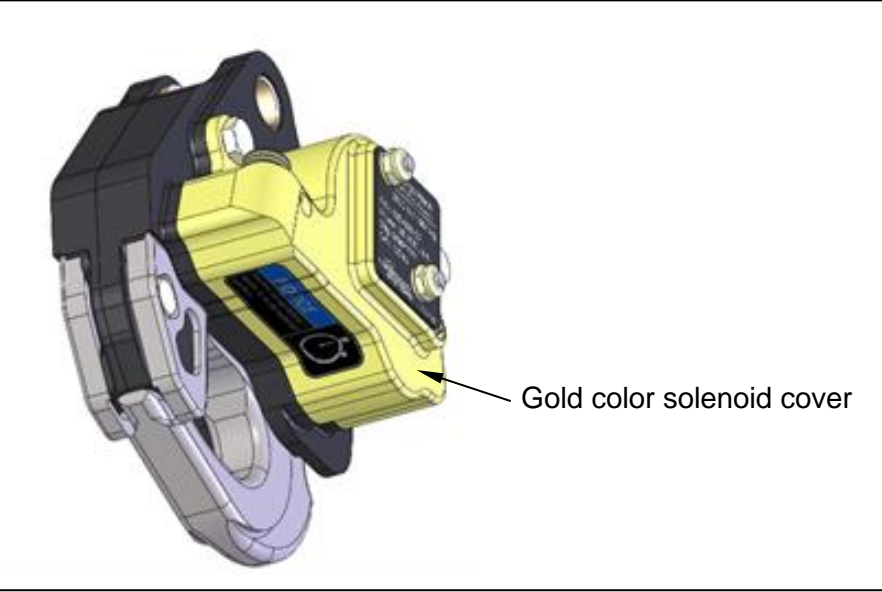

- Very briefly press the Cargo Release switch, the cargo hook should not actuate and the load beam should remain closed.

	Rotorcraft Flight Manual Supplement	Document Number 121-073-00
	Cargo Swing Suspension	Revision 1

- Press and hold the Cargo Release switch for several seconds, the load beam should fall to the open position and the cargo hook solenoid should continue to cycle repeatedly.

NOTICE

By design (to help protect against inadvertent load release) cargo hook P/N 528-028-02 requires that the Cargo Release switch on the cyclic be held for at least ½ second to release the load.

7. Cycle the hydraulic release system to ensure proper operation. Pull the Cargo Release lever on the collective and the cargo hook should open with no load on it. Return the cargo hook to the closed and locked position by manually pushing up on the load beam. The load beam should snap shut. Verify that the hook lock indicator on the side of the hook returns to the fully locked position. In the fully locked position the hook lock indicator should align with the lines on the cover (see Figure 4.1.2). The cargo hook may be flown in the open position to facilitate loading by ground crew.

Figure 4.1.2 Hook Lock Indication

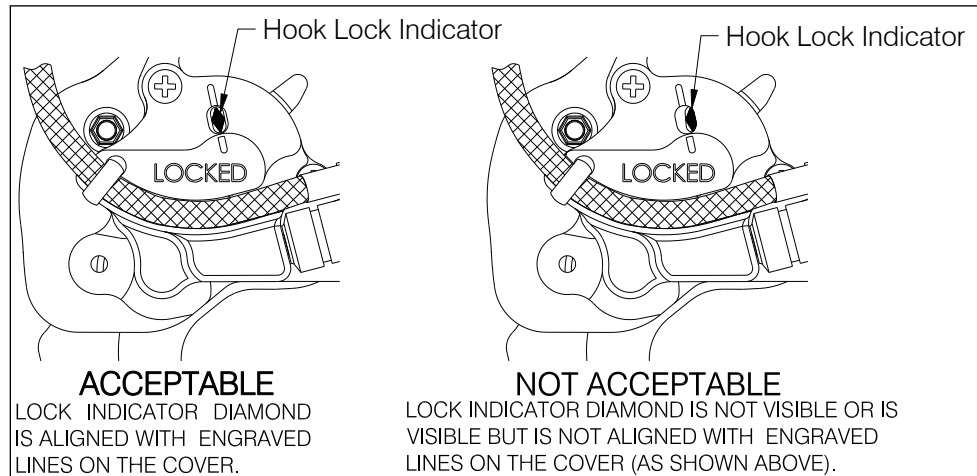

8. Check the fluid level in the master cylinder reservoir. The reservoir features a transparent lid through which the fluid level can be checked. Hydraulic fluid level should be at least partially above the baffle surface, see (Figure 4.1.3).

Figure 4.1.3 Fluid Level

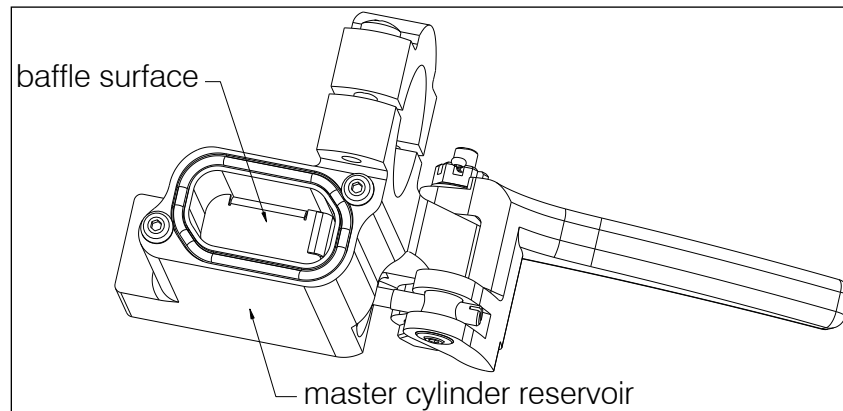

9. Check the hydraulic release system for excess air in the lines by pulling the release lever firmly until it bottoms out. Check the push rod position (see Figure 4.1.4). If some of the green ring on the push rod is still visible, the system is ready for use. If none of the green ring is visible, the system needs to be bled. Refer to applicable ICA for bleed instructions.

Figure 4.1.4 Checking System for Air

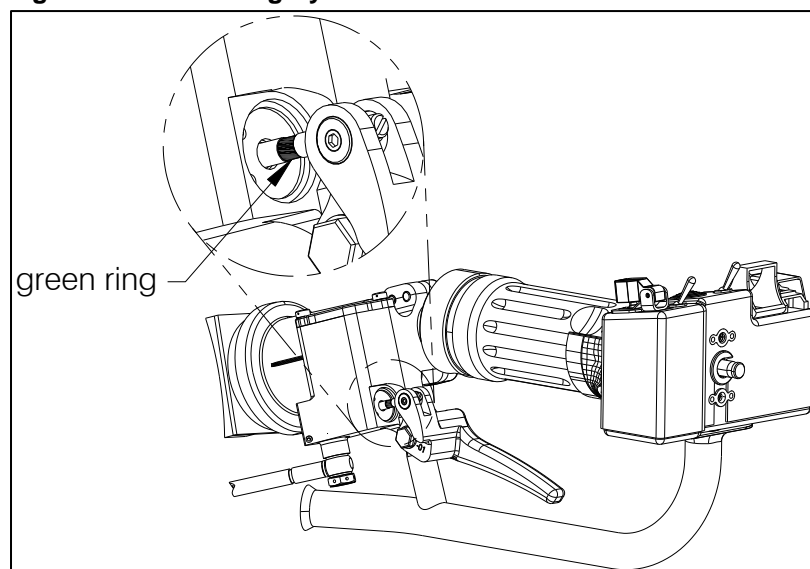

	Rotorcraft Flight Manual Supplement	Document Number 121-073-00
	Cargo Swing Suspension	Revision 1

For the load weigh system, perform the following as part of the pre-flight check. If the C-39 model indicator is installed, skip to step 13.

If the C-40 Load Indicator is not going to be used during a flight, the screen can be turned off by pressing and holding the rotary knob until the screen turns off.

10. Verify the Load Indicator displays the Load screen (shown below). This screen is shown after power up; during power up an Information screen will display the Hook Hours, software version, and the unit's serial number (S/N).

Figure 4.1.5 Load Screen

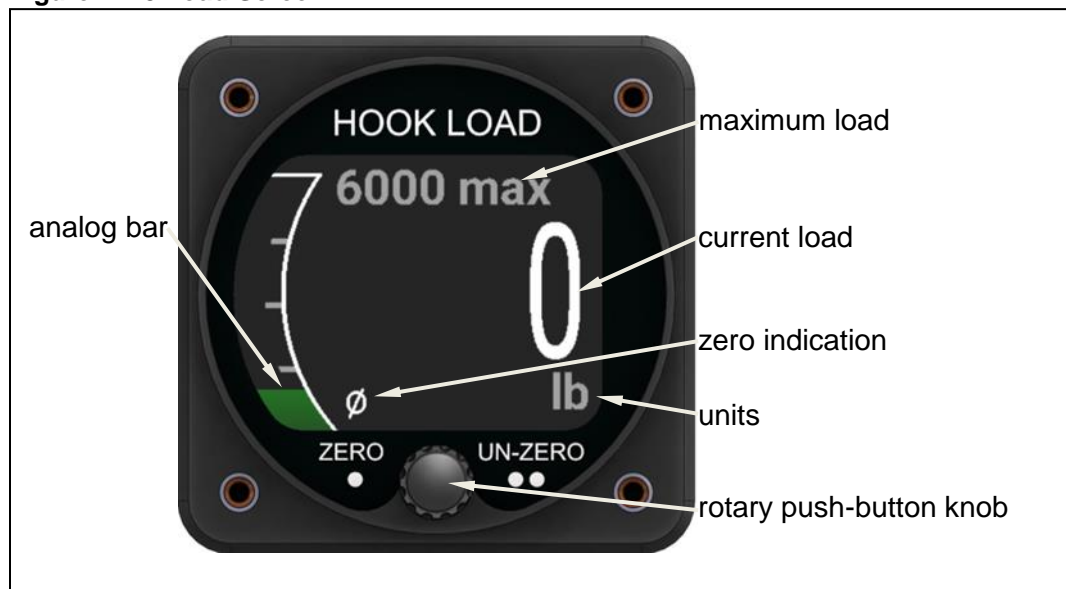

NOTICE

Refer to Owner's Manual 120-152-00 for detailed setup instructions including changing the units, changing the brightness of the display, etc. and additional operation instructions.

	Rotorcraft Flight Manual Supplement	Document Number 121-073-00
	Cargo Swing Suspension	Revision 1

11. Optionally set the maximum load: The C-40 Indicator includes a Maximum Load setting, this setting provides the option to select a maximum load for each flight involving external load operations based on flight conditions (temperature, altitude, fuel, etc.) or it can be set to the maximum external load rating of the rotorcraft. To set the maximum load:

- From the Load screen press and hold the rotary push button knob until the Maximum Load screen appears. Release the knob.

Figure 4.1.6 Maximum Load Screen



- Rotate the knob to the left or right to decrease or increase the value to the desired setting.
 - Press the knob to set this value.
12. To zero (or tare) the weight of the long line, net, remote hook, etc. from the displayed load, apply that weight to the cargo hook and press the knob once and the display should zero out. Press the knob twice to un-zero (un-tare) the display and add this weight back in.

NOTICE

The analog bar always displays the un-zeroed load. If there is a discrepancy between the analog bar and the displayed load, a large amount of load has likely been zeroed.

	Rotorcraft Flight Manual Supplement	Document Number 121-073-00
	Cargo Swing Suspension	Revision 1

If the C-39 Indicator model is installed:

- On power up, after a brief self-diagnostic routine is complete verify the indicator display indicates “0” as shown below (with no load on the cargo hook).

Figure 4.1.7 C-39 Indicator Display

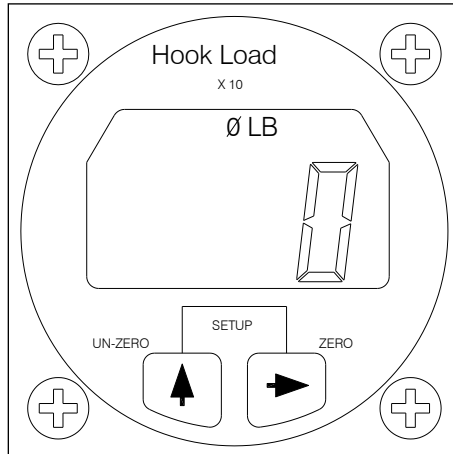

NOTICE

For the C-39 model refer to Owner’s Manual 120-039-00 for setup instructions including changing the units, changing the calibration code, zeroing the display, changing the dampening level, etc.

4.2 Take-off

- Following attachment of the external load, slowly increase the collective pitch and ascend vertically, maintaining the rotorcraft directly above the load.
- When the slack in the long line is removed dwell briefly before lifting the load vertically from the surface.
- Check the load indication on the Load Indicator.
- Check torque required to hover with the external load.
- Check for adequate directional control.
- Take off into the wind, if possible, and proceed to forward climb attitude. Ensure clearance of the external load over obstacles.

	Rotorcraft Flight Manual Supplement	Document Number 121-073-00
	Cargo Swing Suspension	Revision 1

4.3 Maneuvers

Make all control movements gently with gradual acceleration and deceleration and only slightly banked turns.



Control movements should be made gently and kept to a minimum to prevent oscillation of the load and to maintain the external load angle within the limits of rotation of the cargo hook.



The swing suspension is designed to allow the cargo hook to pivot and align with the external load in all directions with limits to protect the cargo hook and suspension frame from damage. Take precautions to prevent external load angles which exceed the limits of rotation provided by the suspension as the load may not be releasable in this position.

	Rotorcraft Flight Manual Supplement	Document Number 121-073-00
	Cargo Swing Suspension	Revision 1

4.4 Approach and Release of External Load

1. Perform the approach at minimum rate of descent.
2. Execute the approach to hover with sufficient height to prevent the load from hitting obstacles on or being dragged along the ground and then slowly descend vertically to set the load on the ground.
3. Press the CARGO RELEASE switch on the cyclic to release the external load from the cargo hook.
4. The CARGO RELEASE lever on the collective may also be used to release the external load in normal circumstances.
5. Visually check to ensure that the external load has been released.



Verify that the external load and long line has dropped free from the rotorcraft before departing the drop-site.

4.5 Cargo Hook Rigging

Exercise care when rigging a load to the Cargo Hook. Attaching the external load using a steel load ring on the Cargo Hook's load beam is the recommended rigging configuration to provide consistent release performance and resistance to fouling. Figure 4.5.1 shows the recommended rigging and rigging to avoid, but is not intended to represent all rigging possibilities. For each rigging configuration used, verify that the rigging will freely slide off the load beam when it is opened.



It is the responsibility of the operator to assure the cargo hook will function properly with the rigging.

Figure 4.5.1 Cargo Hook Rigging

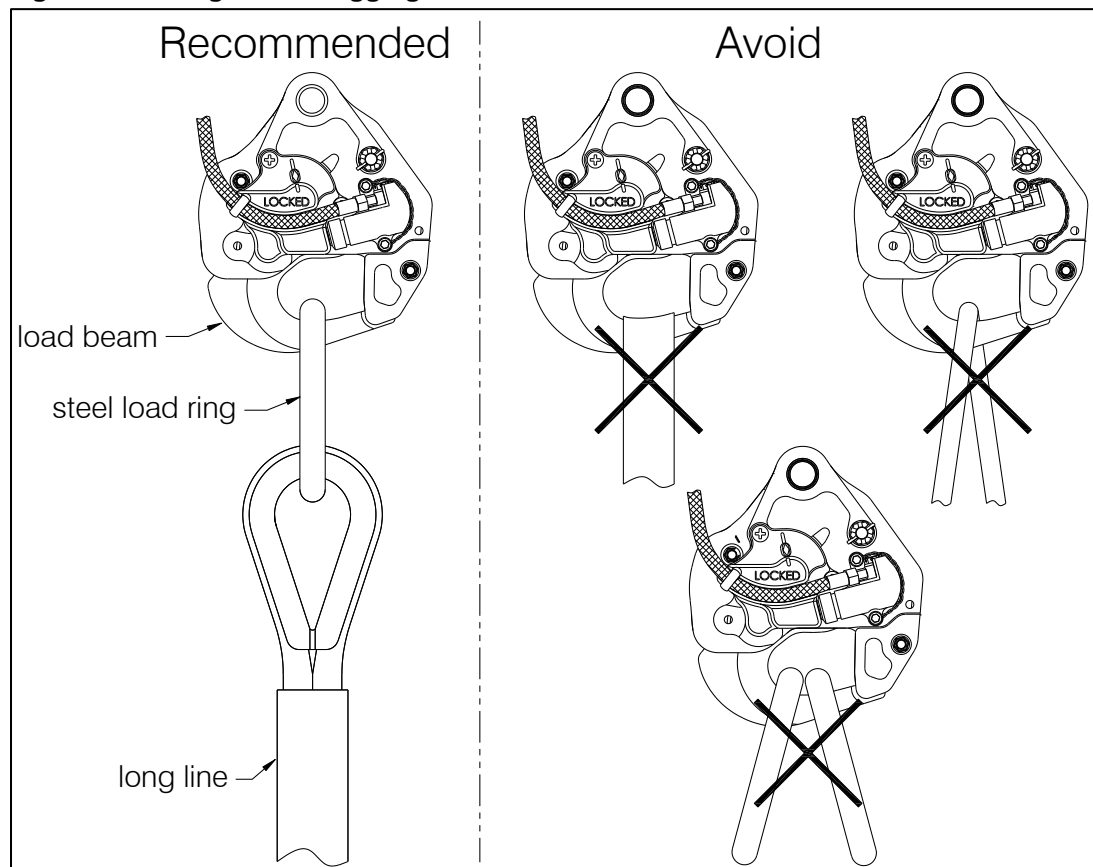

	Rotorcraft Flight Manual Supplement	Document Number 121-073-00
	Cargo Swing Suspension	Revision 1

5.0 Performance

The performance data in basic Flight Manual and in the flight manual supplements remain applicable when no external load is attached to the cargo hook.

Refer to Figure 6 of Section 5.1 § 7 in the basic Flight Manual for hover out of ground effect performance.

Hover and climb performance may be affected when carrying bulky loads.

The Load Weigh System is intended as a means of MONITORING the weight of the load suspended from the Cargo Hook.

Before lifting a load, it is recommended that the load weight be estimated, the shape/size is considered and, upon lifting the load, monitor the load indicator and compare the actual engine torque value vs. the expected value for a given weight to verify sufficient performance.

	Rotorcraft Flight Manual Supplement	Document Number 121-073-00
	Cargo Swing Suspension	Revision 1

6.0 Weight and Balance

The point of application of the external load (i.e. – cargo hook location) in the longitudinal direction is X3437 mm (135.2 in.) and in the lateral direction is Y0.

7.0 System Description

The P/N 200-280-07 and P/N 200-280-08 Cargo Swing Suspension System kits provide the means for an AS350 series rotorcraft to transport jettisonable external loads. These kits consist of a Fixed Provisions Kit (P/N 210-202-04) and a Removable Provisions Kit, P/N 210-201-02 or P/N 210-201-04 (depending on the P/N of the cargo hook).

The Fixed Provision Kit P/N 210-202-04 includes the C-40 Indicator and with the supplied internal wire harness provides the capability to interface and function with the AS350B3 VEMD to increase the main rotor RPM to 400 when a load over 331 lbs (150 kg) is measured on the cargo hook by the load cell. This function is compatible with AS350B3s with MOD 07-4716 incorporated.

The C-40 Indicator Upgrade Kit P/N 200-472-00 provides a means to upgrade a P/N 200-280-03 or P/N 200-280-06 Cargo Swing Suspension System's C-39 Indicator to the C-40 Indicator and connect it to the AS350B3 VEMD.

7.1 Swing Removable Provisions Kit Overview

The Swing Removable Provisions Kits include the components external to the aircraft (ref. Figure 7.1.1 for overview) and are easily removable when a mission does not involve external loads. These kits include the swing frame assembly which supports the cargo hook and load cell, external electrical release and load cell harness, ground strap, and external hydraulic hose assembly. The swing frame assembly serves as part of the means to transfer the external load on the cargo hook to the hard points at the skid gear cross tubes. It is constructed of a welded tubular frame assembly and is attached to the hard points through four structural cable assemblies.

Figure 7.1.1 Overview of Swing Removable Provisions

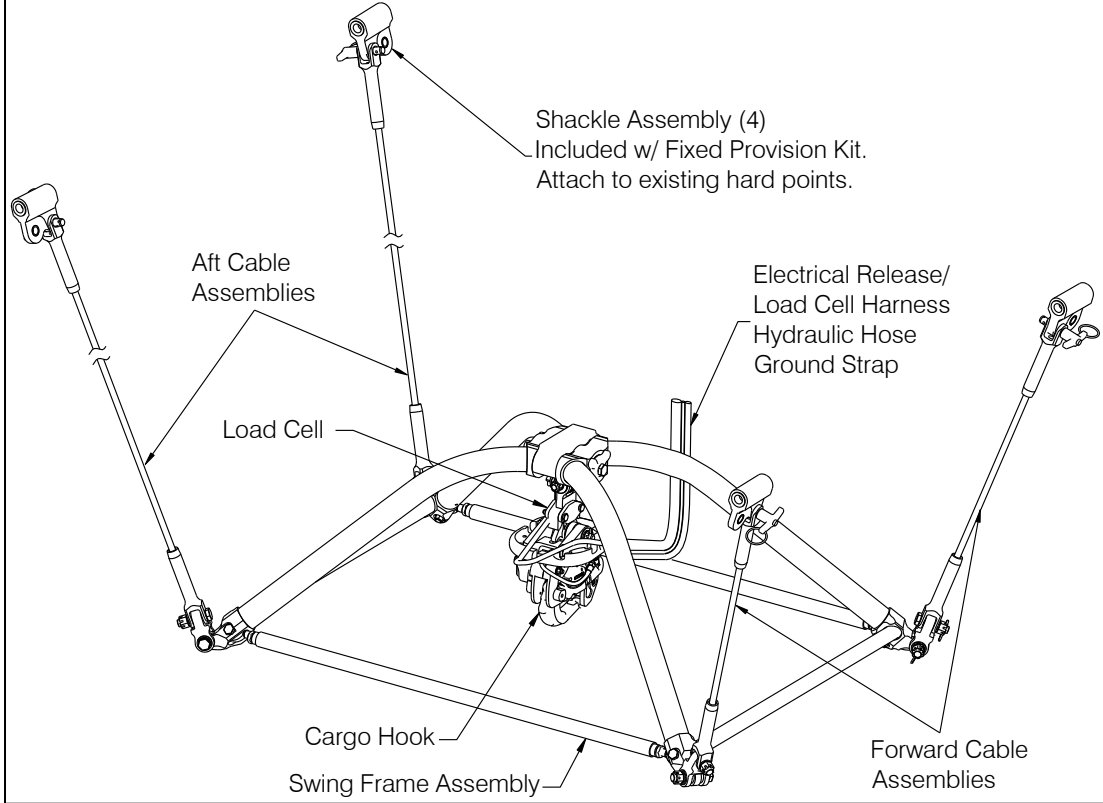

7.2 Fixed Provisions Kit

The Fixed Provisions Kit (P/N 210-202-04) includes the components internal to the aircraft of the cargo hook’s electrical release and hydraulic release systems, and the load weigh system.

The cargo hook’s primary quick release sub-system (PQRS) is an electrical release system which uses the existing type certificate installed push-button switch on the cyclic to actuate it.

The cargo hook’s backup quick release sub-system (BQRS) is a hydraulic release system and is actuated using a Cargo Release lever on the collective (ref. Figure 7.2.1).

Figure 7.2.1 Cargo Release Lever

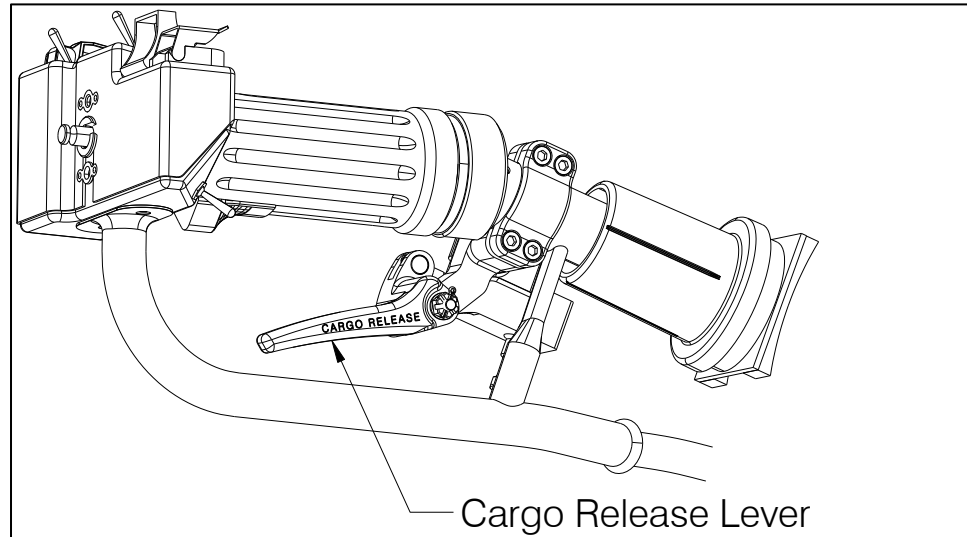

The load weigh system includes the C-40 load indicator (the C-39 model is an optional indicator) on the RH door pillar and the internal wire harness to connect the load cell to the indicator and to pick up aircraft power and ground. The load cell is part of the structural linkage between the cargo hook and the swing frame assembly.