



RFM Supplement to  
MDHI 600N  
Dual Cargo Hook System  
Revision: 0

Supplement No. 121-074-00

STC No. SR02693LA

FAA APPROVED  
ROTORCRAFT FLIGHT MANUAL SUPPLEMENT  
TO THE  
MD HELICOPTERS  
MODEL 600N  
ROTORCRAFT FLIGHT MANUAL

Dual Cargo Hook System  
STC No. SR02693LA

Aircraft S/N \_\_\_\_\_ Aircraft Reg. No. \_\_\_\_\_

FAA Approved: **ALAN W WILSON** Digitally signed by ALAN W WILSON  
Date: 2021.12.23 12:31:13 -09'00'

For: Manager, Northwest Flight Test Section, AIR-715  
Federal Aviation Administration  
Seattle, WA

Date: December 23, 2021




Supplement No. 121-074-00

STC No. SR02693LA

### REVISION HISTORY

When revised, this document will be revised in its entirety.

Rev.	Pages	Description of Change	FAA Approval
0	All	Initial Release HEC Cargo Hook System 600N	ALAN W WILSON  Digitally signed by ALAN W WILSON Date: 2021.12.23 12:31:42 -09'00'



## CONTENTS

SECTION 1 – GENERAL .....	4
Equipment Description .....	5
SECTION 2 - LIMITATIONS.....	7
Operating Limitations .....	7
Weight Limitations .....	8
Center of Gravity Limitations.....	8
Load Limitations .....	9
Airspeed Limitations.....	9
Placards .....	10
SECTION 3 – EMERGENCY AND MALFUNCTION PROCEDURES .....	11
Engine Failure.....	11
Cargo Fails to Release Electrically .....	11
Loss of Y-rope Attachment to Either Cargo Hook .....	11
SECTION 4 – NORMAL PROCEDURES .....	12
Static Electricity Discharge.....	17
Attaching an HEC Load.....	17
Attaching a NHEC Load.....	19
Take-off.....	20
In-flight .....	20
Approach and Release of External Load .....	21
Re-configuring the cargo hook installation.....	21
SECTION 5 – PERFORMANCE DATA.....	21
SECTION 6 – WEIGHT AND BALANCE DATA .....	22



## **SECTION 1 – GENERAL**

Attach this supplement to the FAA Approved Rotorcraft Flight Manual when the aircraft is modified by the installation of an Onboard Systems Dual Cargo Hook System in accordance with STC No. SR02693LA.

The information contained herein supplements or supersedes the basic manual only in those areas listed herein. For limitations, procedures, and performance data not contained in this supplement, consult the Rotorcraft Flight Manual.

The Dual Cargo Hook System for the MD Helicopters' (MDHI) 600N model helicopters provide a means to transport human external cargo (HEC).

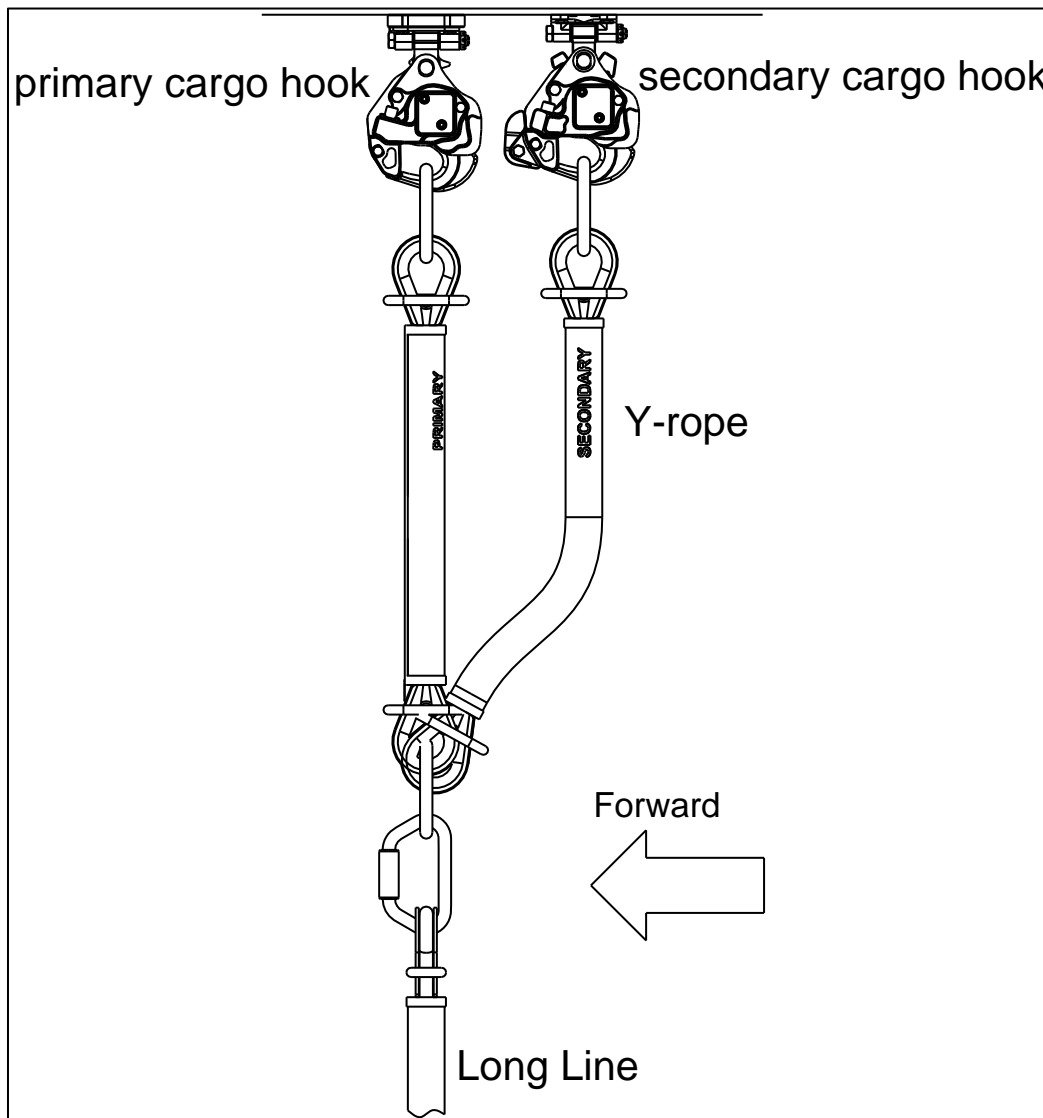
When the Dual Cargo Hook System is installed, an owner or operator holding a valid Rotorcraft External Load Operator Certificate may utilize the helicopter for transportation of external cargo when operated by a qualified pilot. OPERATIONS WITH CARGO ATTACHED TO THE DUAL CARGO HOOK SYSTEM SHALL BE CONDUCTED IN ACCORDANCE WITH APPLICABLE PORTIONS OF FEDERAL AVIATION REGULATIONS PART 133.

Information provided in these operating instructions is presented with the intent of furnishing important data that can be used in the Rotorcraft Load Combination Flight Manual. The Combination Flight Manual, which is required by 14 CFR part 133, will be prepared by the applicant to obtain the Rotorcraft External Load Operator Certificate.

### Equipment Description

The Dual Cargo Hook System is comprised of:

- Dual cargo hooks on the belly of the aircraft for attachment, transport and release of external loads. Transport of HEC requires the use of an Onboard Systems Y-rope (P/N 490-014-00) attached to both the primary and secondary cargo hook.
- An approved long line configuration to provide the means to connect the HEC harness (not included) to the Y-rope. The harness and alternate configurations of the long line will require approval by the local Aviation Authority.

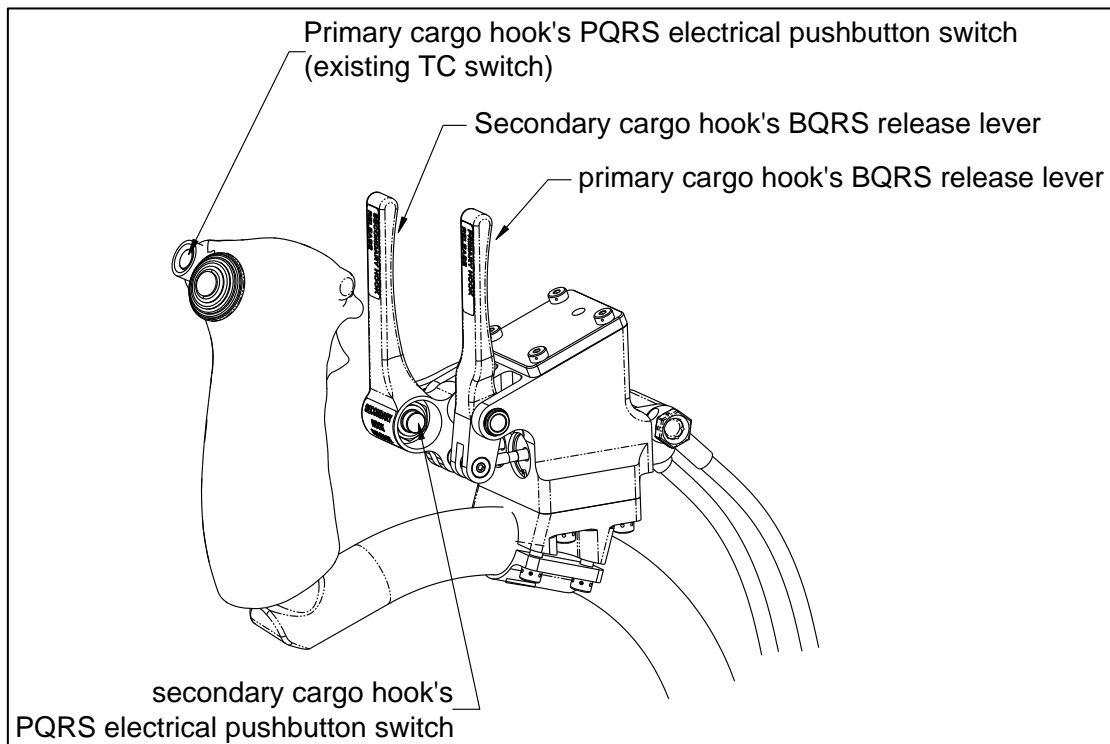


*Figure 1 – Dual Cargo Hook Configuration*

- A primary quick release sub-system (PQRS) and a backup quick release sub-system (BQRS) for each of the cargo hooks including the controls on the cyclic (see **Figure 2**).

The PQRSs are electrical release systems which are actuated by means of pilot actuation of switches on the cyclic. The primary cargo hook interfaces with the existing MD Helicopters' type certificated switch on the cyclic. The PQRS for the secondary cargo hook is actuated by a push-button switch integrated into a BQRS lever of the Dual Master Cylinder Assembly installed on the cyclic per this STC.

The Dual Master Cylinder Assembly includes an independent release lever for backup release of each cargo hook.



**Figure 2 –Cargo Hook Controls**

- An optional Load Weigh System to display the weight of the external load carried on the primary cargo hook. The system consists of three components:
  - The load weigh indicator installed in the instrument panel.
  - A pin load cell installed at the primary cargo hook.
  - An internal electrical wire harness which connects the load weigh indicator to the load cell and to aircraft power and ground

## SECTION 2 - LIMITATIONS

### Operating Limitations

With a load attached to the dual cargo hook system, operation shall be conducted in accordance with the respective national operational requirements.

The dual cargo hook system meets the 14 CFR part 27 certification requirements for Human External Cargo (HEC).

# NOTICE

*The cargo hook equipment certification approval does not constitute operational approval; operational approval for external load operations must be granted by the local Aviation Authority.*

HEC operations require the use of a Personnel Carrying Device Systems (PCDS) harness, which must be approved by the local Aviation Authority. TSO-C167 provides one such acceptable means of approval.

HEC operations require the use of a Personnel Carrying Device Systems (PCDS) Long Line. Using Onboard Systems Part Number 490-015-XX “HEC Long Line” is one acceptable means of approval. The use of alternate (PCDS) longlines must be approved by the local Aviation Authority.

Carrying of HEC requires that the PCDS be attached to both cargo hooks through Onboard Systems Y-Rope P/N 490-014-00 per the instructions contained herein.

This cargo hook system does not include equipment to allow direct intercommunication among required crewmembers and external occupants. Operating this external load equipment with HEC is not authorized unless equipment to allow direct intercommunication among required crewmembers and external occupants is approved by the local Aviation Authority.

The cargo hook system meets the certification requirements for lifting jettisonable external loads free of land or water.

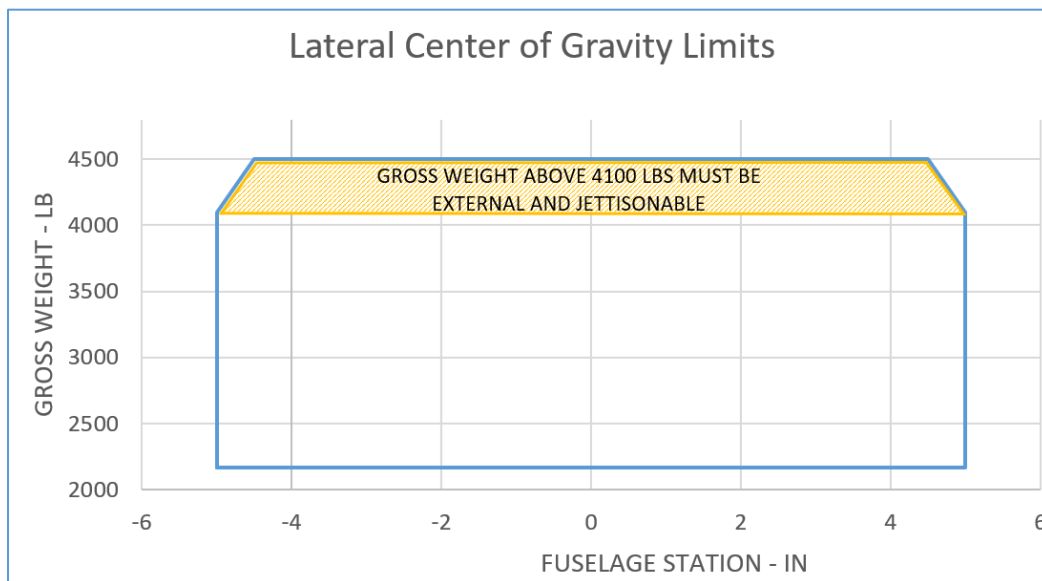
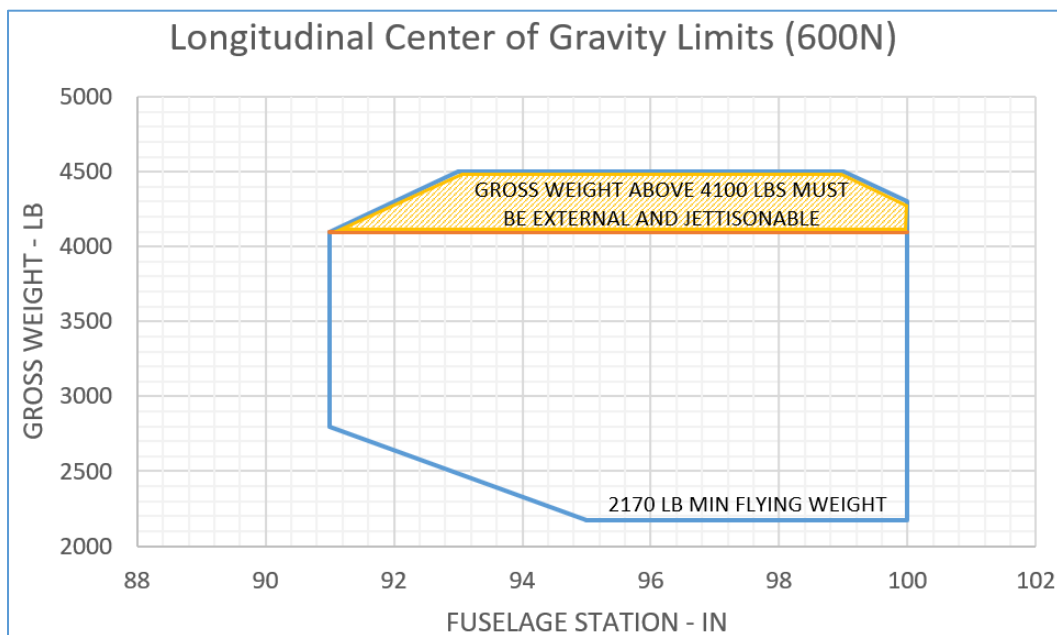
HEC operations require a visual means to monitor the connection of the Y-rope to the cargo hooks. Visual means include but are not limited to an external mirror or a ground observer or external occupant with intercommunication with a crewmember.

**Weight Limitations**

Maximum weight allowed on the landing gear is 4100 pounds. Weight in excess of 4100 pounds must be external and jettisonable. Maximum Rotorcraft - Load Combinations operating gross weight is 4500 pounds (14 CFR Part 133). All lines attached to the dual cargo hook system that extend below the aircraft landing gear, must have a minimum of 25 lbs. of weight attached to the lower end of the line.

**Center of Gravity Limitations**

Center of gravity not to exceed the limits certified for the helicopter.





Supplement No. 121-074-00

STC No. SR02693LA

### **Load Limitations**

The dual cargo hook system load limit is 650 lbs. (295 kg) with the Y-rope attached to both cargo hooks. See loading instructions in Section 4.

The NHEC load limit (with a load attached ONLY to the primary cargo hook) is 2000 lbs. (907 kg).

### **Airspeed Limitations**

With no load on the cargo hooks, airspeed limits are unchanged.

With a load on the cargo hooks, airspeed limits are unchanged from those on the external load  $V_{NE}$  placards presented in the Rotorcraft Flight Manual.



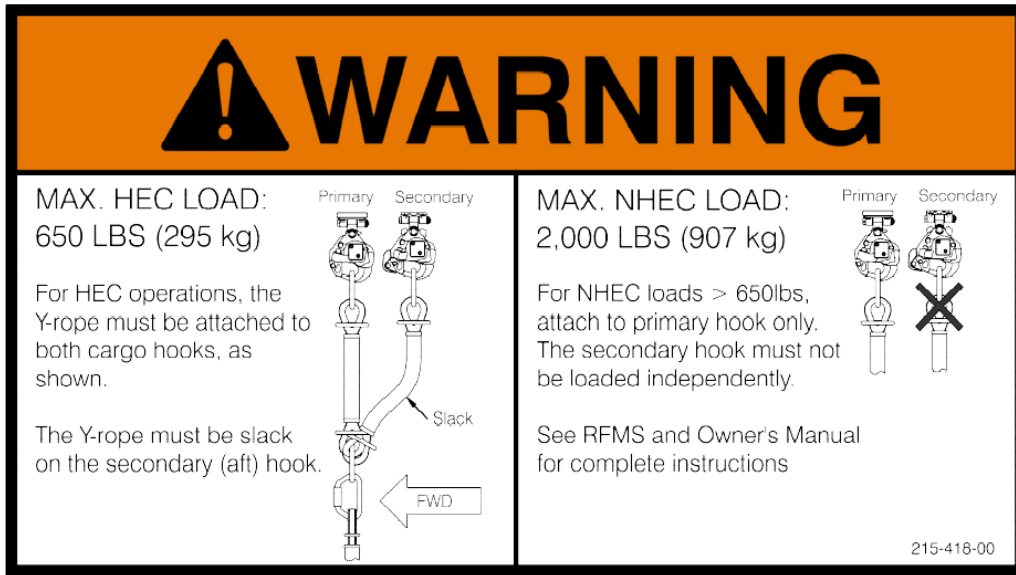
*Use caution as size and shape of load, and load attaching cable size and length may affect flight characteristics.*

Satisfactory flight characteristics have been demonstrated for the dual cargo hook system with a compact 650 lb. load suspended on a ½-inch jacketed rope 100 feet long.

**Placards**

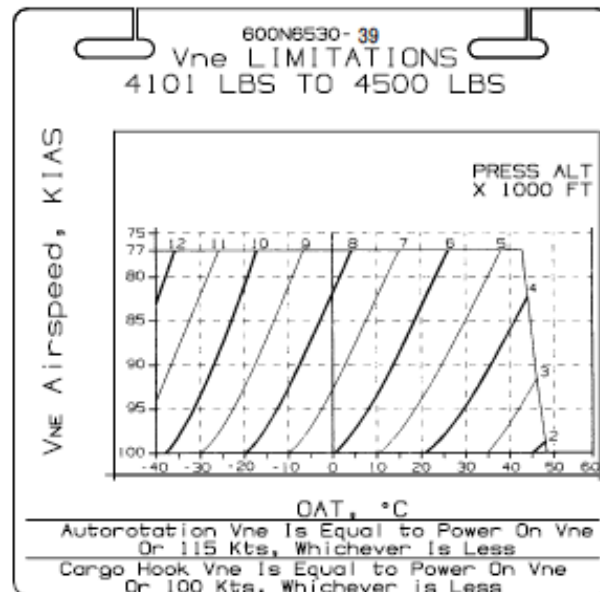
The following placards (ref. **Figure 3**, **Figure 4**, and **Figure 5**) are required with the dual cargo hook system.

Placard P/N 215-418-00 must be installed on the belly adjacent to the primary or secondary cargo hook. See **Figure 3** below.

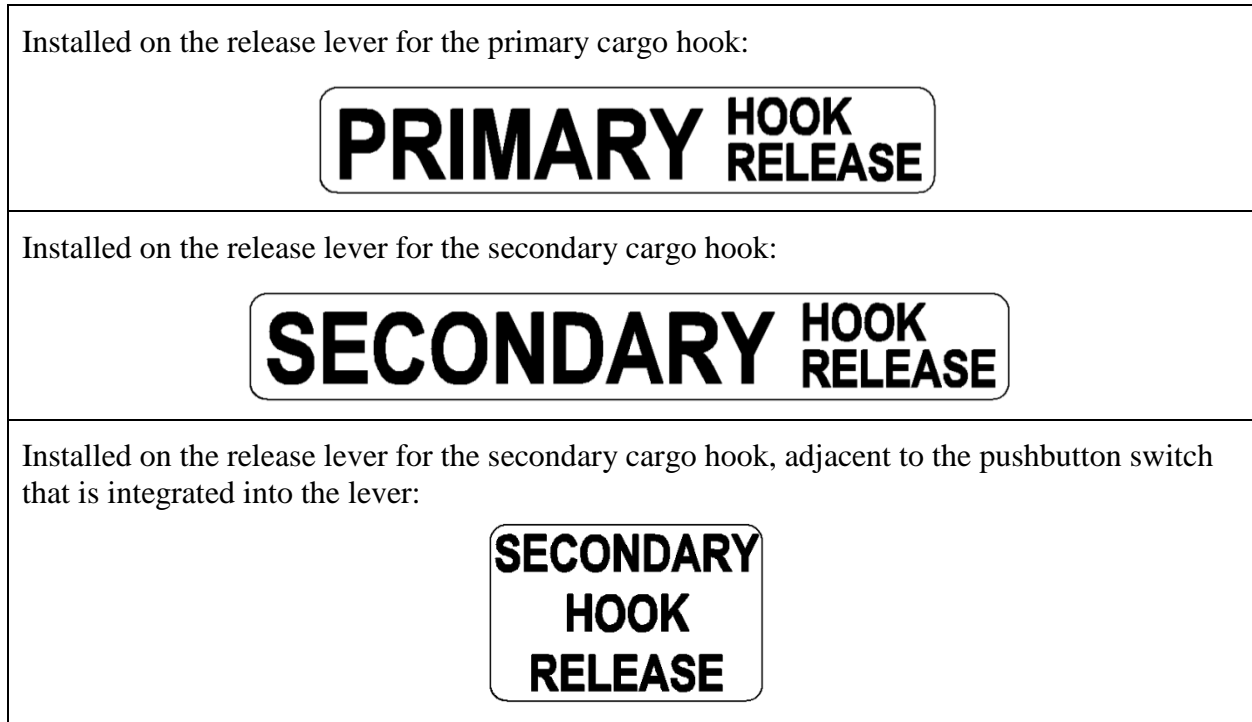


**Figure 3 – External Load Limit Placard**

With load on hook refer to Figure 4 (also figure 10-2 in Basic RFM)  $V_{NE}$  Placard



**Figure 4  $V_{NE}$  Placard**



*Figure 5 – Cargo Hook Controls Placards*

## **SECTION 3 – EMERGENCY AND MALFUNCTION PROCEDURES**

### **Engine Failure**

The presence of an external load may further complicate a failed engine condition. In this situation release the external load as soon as practical; consistent with other safety of flight factors (rotor RPM, altitude, airspeed, ground personnel safety, etc.).

### **Cargo Fails to Release Electrically**

In the event that the Cargo Hook System will not release the external load electrically, proceed as follows:

1. Maintain tension on the sling.
2. Pull the Secondary Hook and Primary Hook release levers on the cyclic in succession.

### **Loss of Y-rope Attachment to Either Cargo Hook**

Land the rotorcraft as soon as practical.

## SECTION 4 – NORMAL PROCEDURES

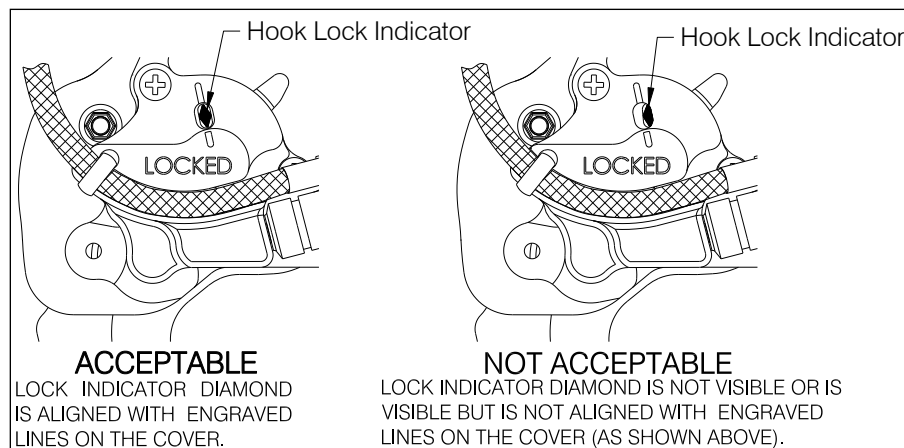
### Pre-flight

Before a flight involving external load operations perform the following procedures. If the procedures are not successful do not use the equipment until the problem has been corrected.

1. Check all cargo hook and cargo hook control mounting fasteners to ensure they are secure.
2. Check the cargo hook electrical and hydraulic connections at the cargo hook and at the connector panel on the belly for damage and security.
3. Check the slave cylinders on the cargo hooks for signs of hydraulic fluid leakage.
4. Swing the cargo hooks to their full travel extremes to verify that they do not reach the range of motion limits of the electrical harnesses and hydraulic hoses.
5. Check the operation of the cargo hooks' PQRS to ensure proper operation
  - Place battery switch in BAT position and check HOOK circuit breaker is in.
  - Press the primary cargo hook's electrical switch mounted in the cyclic grip; with no load on it the cargo hook load beam should fall to the open position.
  - Push up on the load beam and verify that it latches and the hook lock indicator is aligned with the engraved line on the manual release cover (see **Figure 6**).
  - Repeat for the secondary cargo hook (if HEC operations are being performed).

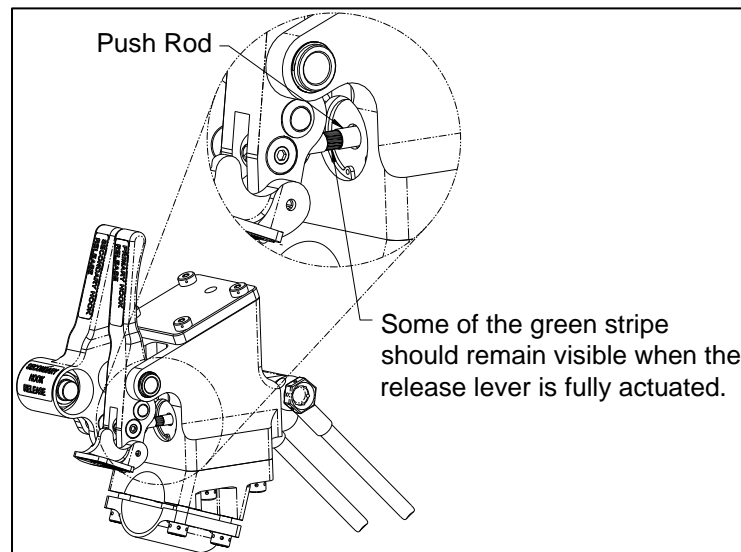


*In the closed position the hook lock indicator should align with the lines on the cover to confirm proper operation (see Figure below).*



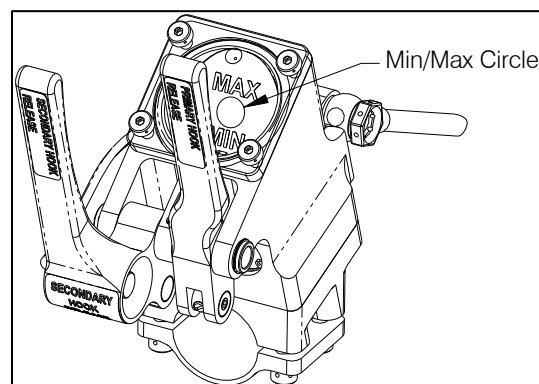
**Figure 6 – Hook Lock Indicator**

6. Check the operation of the cargo hooks' BQRS.
  - Pull the release lever for the primary cargo hook. With no load on it the cargo hook should open. The cargo hook may be flown in the open position to facilitate loading by ground crew.
  - Repeat for the secondary cargo hook (if HEC operations are being performed).
7. Check the BQRS' hydraulic release systems for excess air in the lines. Pull the primary release lever firmly until it bottoms out. Check the push rod position (see **Figure 7**). If some of the green ring on the push rod is visible, the system is ready for use. If none of the green ring is visible, the system needs to be bled. Repeat with the secondary release lever.



**Figure 7 – Checking Hydraulic Release System for Air**

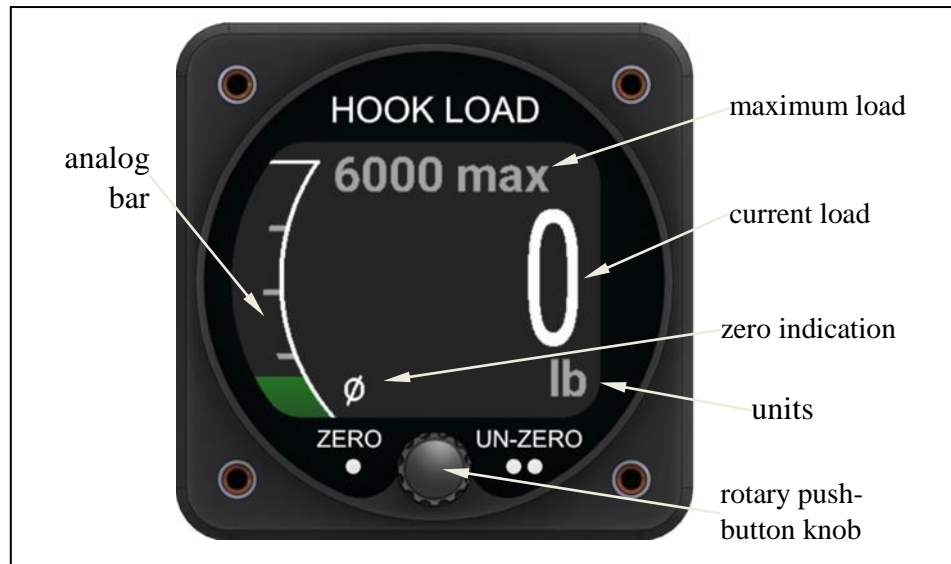
8. Check the fluid level in the master cylinder reservoir. The master cylinder reservoir features a transparent lid through which the fluid level can be checked. The fluid level should be within the range indicated by the circle on the baffle plate in the reservoir.



**Figure 8 – Fluid Level**

9. If the optional load weigh system is installed, procedures vary depending on the Indicator model installed. Refer to the following.

**For the C-40 model.** On power up, an Information screen will display the Hook Hours, software version, and serial number (S/N) and then the indicator should display the Load screen. The Load screen of the C-40 model is shown below.



*Figure 9 C-40 Indicator Load Screen*

## NOTICE

*For the C-40 model refer to Owner's Manual 120-152-00 for detailed setup instructions including changing the units, changing the brightness of the display, etc. and additional operation instructions.*

The C-40 model includes a Maximum Load setting, this setting provides the option to select a maximum load for each flight involving external load operations based on flight conditions (temperature, altitude, fuel, etc.) or it can be set to the maximum external load rating for the helicopter. To set the maximum load:

- From the Load screen press and hold the rotary push button knob until the Maximum Load screen appears (see **Figure 10**). Release the knob.
- Rotate the knob to the left or right to decrease or increase the value to the desired setting.
- Press the knob to set this value.



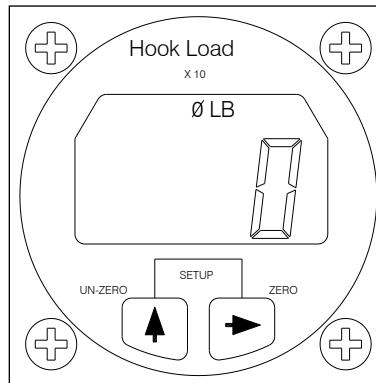
*Figure 10 Maximum Load Screen*

To zero (or tare) the weight of the long line, net, remote hook, etc. from the displayed load, apply that weight to the cargo hook and press the knob once and the display should zero out. Press the knob twice to un-zero (un-tare) the display and add this weight back in.

## **NOTICE**

*The analog bar always displays the un-zeroed load. If there is a discrepancy between the analog bar and the displayed load, a large amount of load has likely been zeroed.*

**For the C-39 model.** On power up, after a brief self-diagnostic routine is complete verify the indicator display indicates “0” as shown below (with no load on the cargo hook).



*Figure 11 C-39 Indicator Display*

## NOTICE

*For the C-39 model refer to Owner's Manual 120-039-00 for setup instructions including changing the units, changing the calibration code, zeroing the display, changing the dampening level, etc.*



**Static Electricity Discharge**

Instruct ground crew to ensure that the helicopter has been electrically grounded prior to attaching the load to drain charge of static

**Attaching an HEC Load**

For carrying of HEC, Onboard Systems Y-rope P/N 490-014-00 must be used. The Y-rope has a PRIMARY leg and a SECONDARY leg. These are different lengths, are labeled, and are color-coded (the PRIMARY leg is green and is shorter than the SECONDARY leg which is orange).

Attach the Y-rope to the cargo hooks as follows (see **Figure 12**)

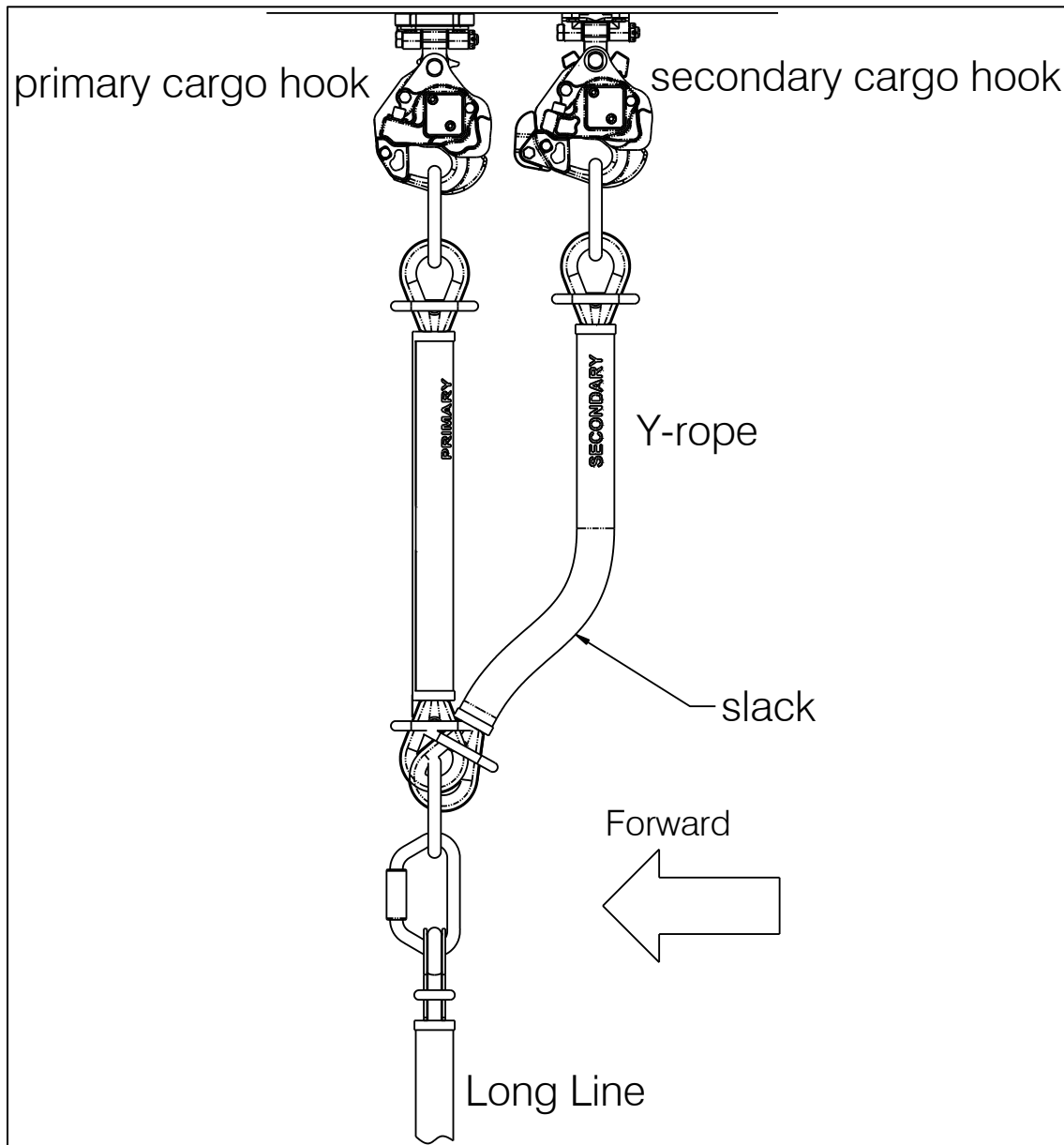
- Attach the green PRIMARY leg of the Y-Rope to the primary (forward) cargo hook
- Attach the longer (orange) SECONDARY leg to the secondary (aft) cargo hook.



*The secondary cargo hook is a backup means of securing an HEC load and should never be loaded independently and should only be used with the slack line of the Y-rope connected to it. The external load limit is 650 lbs. when using the Secondary Cargo Hook.*



*Use care to avoid passing load attaching cables over landing gear skid tube when attaching a load to cargo hook with helicopter on the ground.*

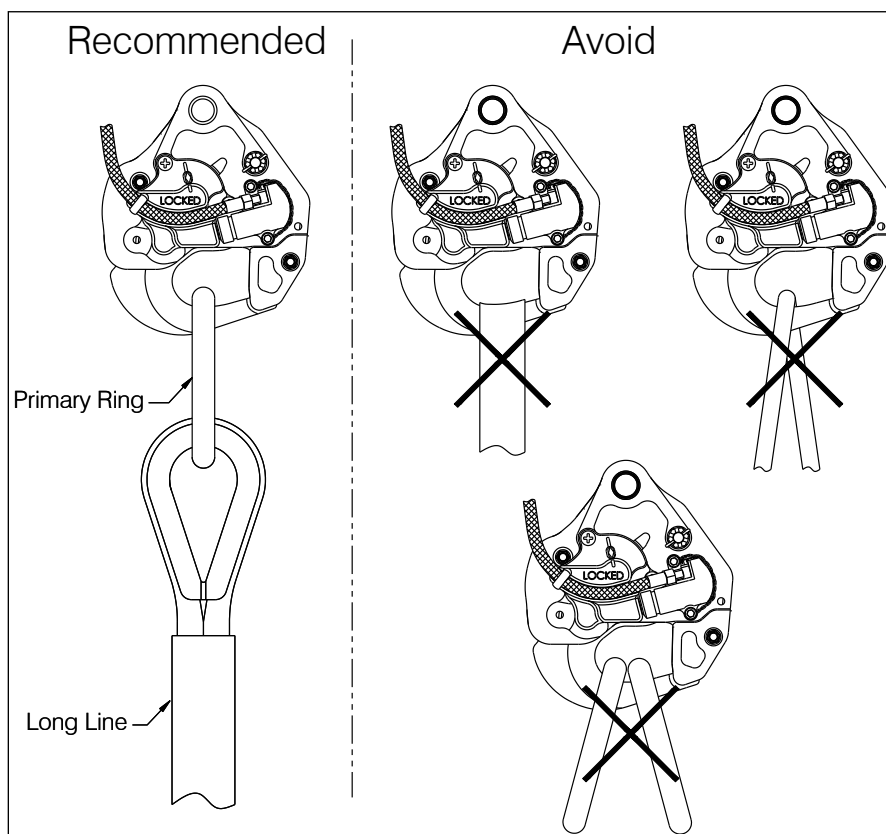


**Figure 12 – Y-rope Attachment to Cargo Hooks**

**Attaching a NHEC Load**

When carrying equipment weighing **less than 650 lbs.** in support of HEC operations (e.g. - ferrying HEC and then equipment back and forth to electrical tower), the SECONDARY line of the Y-ropes may remain attached to the secondary cargo hook (as long as 650 lb. limit is **NOT** exceeded).

See **Figure 13** for the recommended rigging configuration and configurations to avoid when carrying NHEC loads on the primary cargo hook. The examples shown are not intended to represent all possibilities. For each rigging configuration used, verify that the rigging will freely slide off the load beam when it is opened.



**Figure 13 – Examples of Cargo Hook Rigging**



*It is the responsibility of the operator to ensure the hook will function properly with the rigging.*

**Take-off**

1. Following attachment of the external load, slowly increase the collective pitch and ascend vertically, maintaining the rotorcraft directly above the load. When the slack in the long line is removed dwell briefly before lifting the load from the surface.
2. Check torque required to hover with the external load.
3. Check for adequate directional control.
4. Take off into the wind, if possible, and ensure clearance of the external load over obstacles.

**In-flight**

Check HOOK circuit breaker is IN.

Make all control movements gently with gradual acceleration and deceleration and only slightly banked turns.

Maximum airspeed is dependent upon the size, weight, and shape of the external load and sling length. Closely observe the behavior of the load during flight and as airspeed is increased.



*Use caution when flying with an unloaded long line as this is an extreme snag hazard.*

### **Approach and Release of External Load**

1. Perform the approach at minimum rate of descent.
2. Execute the approach to hover with sufficient height to prevent the load from hitting obstacles on or being dragged along the ground and then slowly descend vertically to set the load on the ground.
3. Press the pushbutton switch on the cyclic to release the external load from the cargo hook.  
  
For dual cargo hook operations, press the secondary release switch mounted in the release lever to release the secondary cargo hook and then press the switch on the cyclic grip to release the external load from the primary cargo hook.
4. The release levers on the cyclic are intended as a backup release in the event of an inability to release the load with the push-button switches but may be used to release the external load in normal circumstances.
5. Visually check to ensure that the external load has been released.



*Verify that the external load and long line has dropped free from the rotorcraft before departing the drop-site.*

### **Re-configuring the cargo hook installation**

For operations outside of those approved under this STC, the primary cargo hook can be re-located (for example - back and forth between a side puller) by the pilot when an approved quick release pin is used to attach the cargo hook.

For NHEC operations the rotorcraft may be operated with the secondary cargo hook removed. In this configuration, identify the secondary cargo hook's release lever on the cyclic as inoperative.

## **SECTION 5 – PERFORMANCE DATA**

**NO CHANGE** – Refer to the Rotorcraft Flight Manual Section V for IGE hover performance or Section IX for OGE hover performance to assist in planning operations.

## SECTION 6 – WEIGHT AND BALANCE DATA

The following table of Secondary Cargo Hook Loading Data should be used by the operator to assist in evaluating the helicopter center of gravity for various payload weights.

### Primary Cargo Hook Loading Data:

Primary Cargo Hook Longitudinal CG = 99.3 Primary Cargo Hook Weight 4.7 lb	
Cargo Weight (lb)	Moment/100 (in-lb)
200	199
400	397
600	596
800	794
1000	993
1200	1191
1400	1390
1600	1589
1800	1789
2000	1986

### Secondary Cargo Hook (HEC) Loading Data:

Secondary Cargo Hook Longitudinal CG = 105.2 Secondary Cargo Hook Weight 4.3 lb	
Cargo Weight (lb)	Moment/100 (in-lb)
200	210
400	421
600	631
650 (MAX)	684



*The table above is for planning in case of an inadvertent release of cargo from the primary cargo hook, arrested by the secondary cargo hook. AFT CG limits can easily be exceeded in this configuration.*