	Rotorcraft Flight Manual Supplement	Document Number 121-076-00
	Bell 429 Dual Cargo Hook System	Revision 0

ROTORCRAFT FLIGHT MANUAL SUPPLEMENT

Dual Cargo Hook System

on the

Bell 429

STC SR02806SE

For rotorcraft approved to operate in accordance with the provisions of this rotorcraft flight manual supplement, the information contained herein supplements the information of the basic flight manual. For limitations, procedures, and performance data not contained in this supplement, consult the basic flight manual.

R/N _____ S/N _____

Alan Wilson, FTP, AIR-713 for

Manager, Flight Test & Human Factors Branch, AIR-710
Federal Aviation Administration

July 31, 2024

Approved Date

	Rotorcraft Flight Manual Supplement	Document Number 121-076-00
	Bell 429 Dual Cargo Hook System	Revision 0

Log of Revisions

Revision	FAA Approval	Summary Description
0	Alan Wilson FTP, AIR-713 July 31, 2024	Initial Release

Register Your Products for Automatic Notifications

Onboard Systems offers a free notification service via fax or email for product alerts and documentation updates. By registering your Onboard Systems products at our website, we will be able to contact you if a service bulletin is issued, or if the documentation is updated.

You can choose to receive notices on an immediate, weekly, or monthly schedule via fax, email or both methods. There is no charge for this service. Please visit our website at www.onboardsystems.com/notify.php to get started.

[Please check our web site www.onboardsystems.com](http://www.onboardsystems.com)
[for the latest revision of this manual.](#)

	Rotorcraft Flight Manual Supplement	Document Number 121-076-00
	Bell 429 Dual Cargo Hook System	Revision 0

Table of Contents

General Information4

Part I, FAA Approved Pages

1.0 Limitations5

2.0 Normal Procedures.....9

3.0 Emergency Procedures22

4.0 Performance.....22

Part II, Manufacturer’s Data (Not FAA Approved)

5.0 Weight and Balance23

6.0 System Description.....23

Date: July 31, 2024

Page **3** of **26**

NOT FAA APPROVED

	Rotorcraft Flight Manual Supplement	Document Number 121-076-00
	Bell 429 Dual Cargo Hook System	Revision 0

General Information

Attach this supplement to the appropriate FAA approved Rotorcraft Flight Manual when an Onboard Systems International, LLC Dual Cargo Hook System (P/N 200-483 series, P/N 200-493 series, or P/N 200-494 series) is installed in accordance with Supplemental Type Certificate (STC) SR02806SE. Reference Section 6.0 for descriptions of the system.

Date: July 31, 2024

Page 4 of 26

NOT FAA APPROVED

	Rotorcraft Flight Manual Supplement	Document Number 121-076-00
	Bell 429 Dual Cargo Hook System	Revision 0

1.0 Limitations

The limitations specified in the basic Flight Manual remain applicable and are complemented by the information contained in the section.

1.3 Types of Operation

The dual cargo hook system is approved for Non-Human External Cargo (NHEC) and it meets the 14 CFR part 27 certification requirements for Human External Cargo (HEC).

Cargo hook equipment certification approval does not constitute operational approval; operational approval for external load operations must be granted by the local Aviation Authority.

The dual cargo hook system meets the certification requirements for lifting jettisonable external loads free of land or water.

Carrying of HEC requires that the Personnel Carrying Device Systems (PCDS) be attached to both cargo hooks through Onboard Systems Y-Rope P/N 490-024-00 per the instructions contained herein.

HEC operations require the use of a PCDS harness, which must be approved by the local Aviation Authority.

HEC operations require the use of a PCDS Long Line, which must be approved by the local Aviation Authority. Using Onboard Systems part number 490-023 series "HEC Long Line" provides one such acceptable means of approval.

The dual cargo hook system does not include equipment to allow direct intercommunication among required crew members and external occupants. Operating this external load equipment with HEC is not authorized unless equipment to allow direct intercommunication among required crew members and external occupants is approved by the local Aviation Authority.

Operation of the dual cargo hook system requires a visual means to monitor the connection of the Y-rope to the cargo hooks. Visual means include but are not limited to an external mirror or a ground observer or external occupant with intercommunication with a crewmember.

	Rotorcraft Flight Manual Supplement	Document Number 121-076-00
	Bell 429 Dual Cargo Hook System	Revision 0

1.6 Weight and Center of Gravity

1.6.1 Weight

For HEC, maximum external load is 1322 lb. (600 kg).

The gross weight of the aircraft must not exceed the maximum internal gross weight when carrying an HEC load and may be further limited by 2-min OEI performance limits.

For NHEC, maximum external load is 3000 lb (1360 kg).

All lines attached to the dual cargo hook system that extend below the aircraft landing gear must have a minimum of 25 lbs (11.3 kg) of weight attached to the lower end of the line.

If the Y-rope remains attached to the HEC hook while carrying an NHEC load, the maximum permitted load weight is 1322 lbs (600 kg).

1.6.2 Center of Gravity

Refer to Gross Weight Center of Gravity Limits charts (BHT-429-FM-1).

1.7 Airspeed

For HEC operations, maximum permitted airspeed is 60 KIAS.

For NHEC operations, maximum permitted airspeed is 120 KIAS or placarded V_{NE} , whichever is less.

	Rotorcraft Flight Manual Supplement	Document Number 121-076-00
	Bell 429 Dual Cargo Hook System	Revision 0

1.20 Placards

The following placards are included with the Dual Cargo Hook System.

Installed on the belly adjacent to the cargo hook frame.

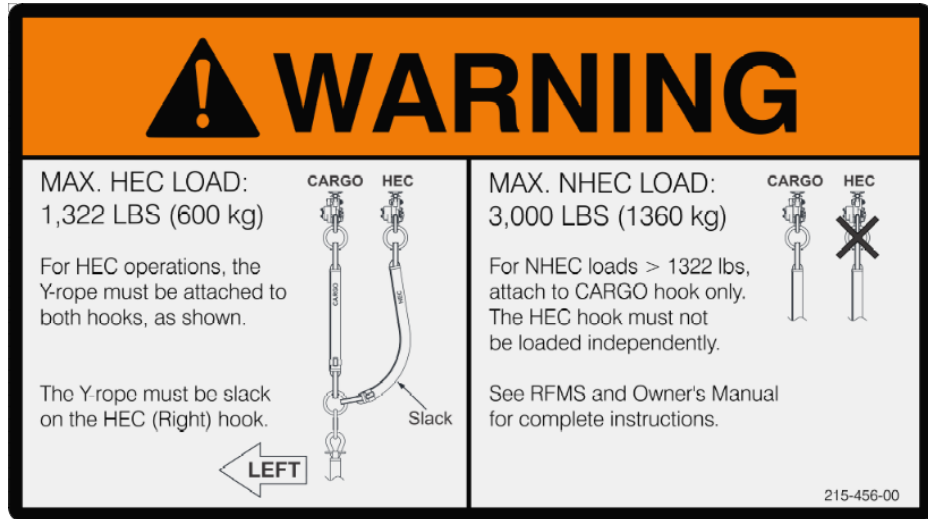

Installed on the bottom of the cargo hook frame near to the HEC Hook, color is orange:



Installed on the bottom of the cargo hook frame near to the CARGO Hook, color is green:







	Rotorcraft Flight Manual Supplement	Document Number 121-076-00
	Bell 429 Dual Cargo Hook System	Revision 0

Figure 1.20.1 Cargo Hook Controls Placards

<p>Installed on the Cargo Hook release lever on the collective:</p> 
<p>Installed on the HEC Hook release lever on the collective:</p> 
<p>Installed on the lockout lever, adjacent to the release levers:</p> 

	Rotorcraft Flight Manual Supplement	Document Number 121-076-00
	Bell 429 Dual Cargo Hook System	Revision 0

2.0 Normal Procedures

The normal procedures in the basic Rotorcraft Flight Manual are applicable and are complemented by the procedures in this section.

2.2 Flight Planning

Prior to attaching an external load, instruct the ground crew to ensure that the helicopter has been electrically grounded to discharge static electricity. If possible, maintain ground contact until hook up is completed.

2.2.1 Attaching an HEC Load

For carrying of HEC, use Onboard Systems Y-rope P/N 490-024-00. The Y-rope has a primary CARGO Leg and a secondary HEC leg. These are different lengths, are labeled, and are color-coded (the CARGO leg is green and is shorter than the HEC leg which is orange).

Attach the Y-rope to the cargo hooks as follows (see Figure 2.2.1).

- Attach the green CARGO leg of the Y-Rope to the Cargo Hook. The Cargo Hook is at aircraft center line.
- Attach the longer orange HEC leg to the HEC Hook. The HEC Hook is to the right of the aircraft center line. Orange and green placards are affixed to the frame adjacent to the respective cargo hook to provide a color-coded means of connecting the Y-ropes.





The HEC Hook is a backup means for securing an HEC load and should NEVER be loaded independently and should only be used with the slack line of the Y-rope connected to it. The external load limit is 1322 lbs when using the HEC Hook.

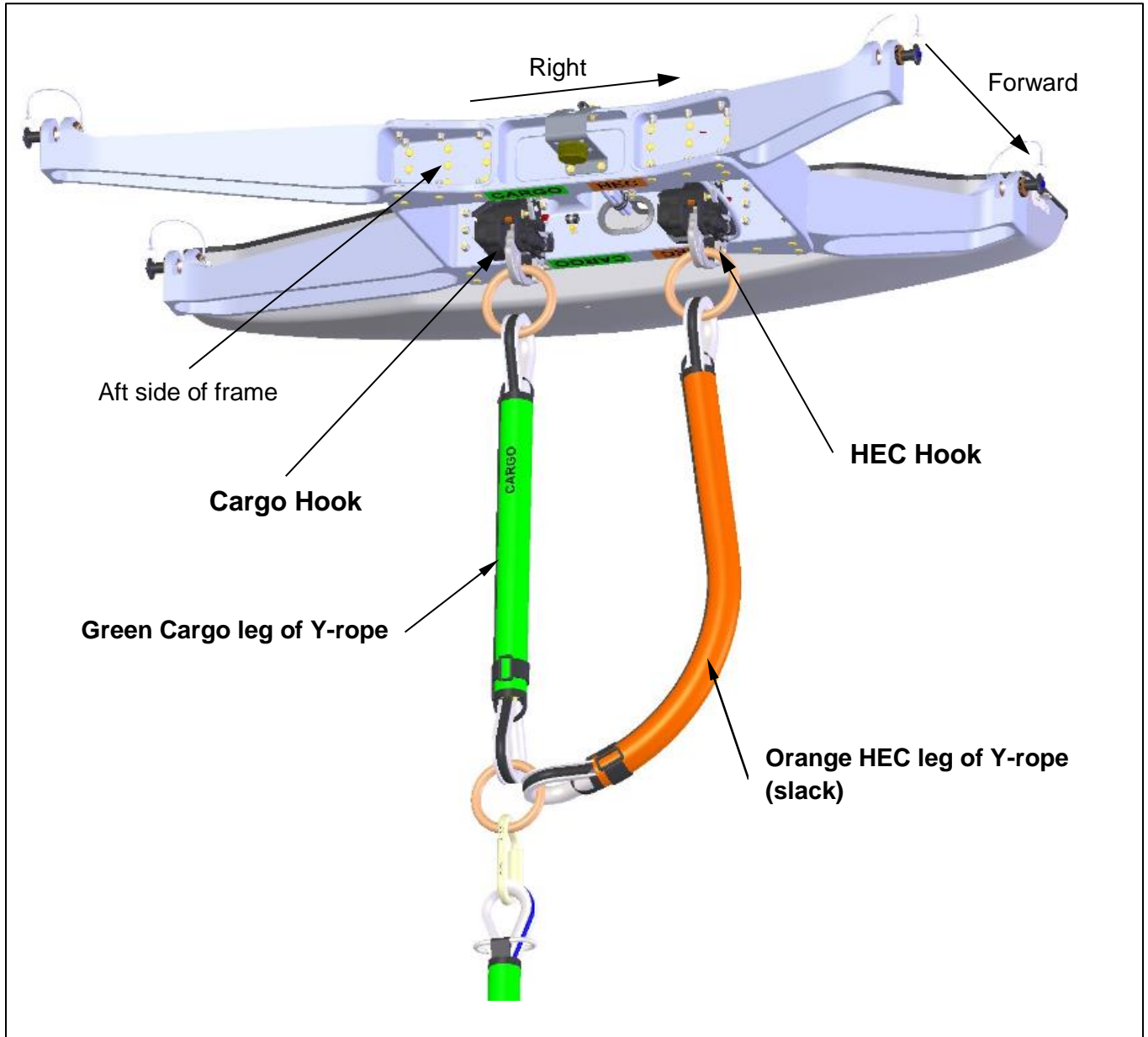

Instruct ground crew to ensure that the helicopter has been electrically grounded prior to attaching the load to drain charge of static.

Figure 2.2.1 Y-rope Attachment to Cargo Hooks



	Rotorcraft Flight Manual Supplement	Document Number 121-076-00
	Bell 429 Dual Cargo Hook System	Revision 0

2.2.2 Attaching an NHEC Load

The HEC line of the Y-rope may remain attached to the HEC Hook while carrying equipment (NHEC) in support of HEC operations as long as the 1322 lb HEC load limit is NOT exceeded.

For NHEC operations, see Figure 2.2.2 for the recommended rigging configuration and configurations to avoid when carrying NHEC loads on the primary cargo hook. The examples shown are not intended to represent all possibilities.





Nylon type straps or rope should not be used directly on the cargo hook load beam. If nylon straps or rope are used they should be first attached to a steel primary ring. Verify that the ring will freely slide off the load beam when it is opened. Only the primary ring should be in contact with the load beam.

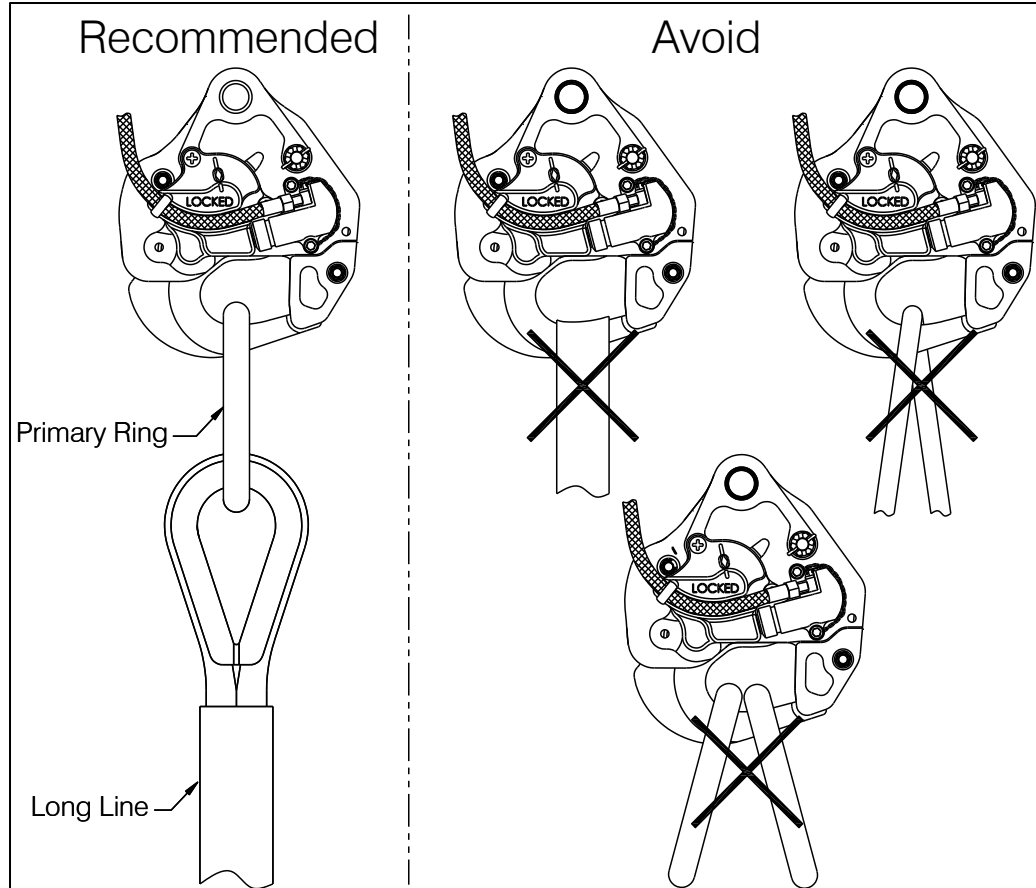

It is the responsibility of the operator to ensure the cargo hook will function properly with the rigging.

Figure 2.2.2 Cargo Hook Rigging



	Rotorcraft Flight Manual Supplement	Document Number 121-076-00
	Bell 429 Dual Cargo Hook System	Revision 0

2.3 Pre-flight Check

Prior to a flight involving external load operations perform the following.

2.3.1 Exterior Check

1. Visually check that all fasteners on cargo hooks and the frame assembly are present and secure.
2. Visually ensure that the pins are present and secure at each of the four frame attachment points to the aircraft.
3. Visually check the cargo hooks and the support frame for damage.
4. Visually check for damage and security of the Fairing Assembly.

2.3.2 Interior Check

1. Set the BATT switch to ON.
2. Set the CARGO HOOK ARM switch to the ARM position. Check that "CARGO HK ARM" is displayed on the EICAS.
3. Press the CARGO REL switch on the cyclic, the primary cargo hook's load beam should fall to the open position. The CARGO HK ARM message should temporarily go out when the switch is pressed.
4. Press the HEC HOOK REL switch on the collective, the HEC Hook's load beam should fall to the open position. The CARGO HK ARM message should temporarily go out when the switch is pressed.

NOTICE

The dual cargo hook system uses the TC push-button release switches (ref. Figure 2.3.1) labeled CARGO REL located on the cyclic (for Cargo Hook) and HEC HOOK REL located on the collective (for HEC Hook).

	Rotorcraft Flight Manual Supplement	Document Number 121-076-00
	Bell 429 Dual Cargo Hook System	Revision 0

Figure 2.3.1 Release Switches



5. Close each cargo hook by manually pushing up on the load beam until it latches.
6. Position the HEC/NHEC selector lever depending on the type of external load operation to be conducted. Refer to the following.

For Non-HEC operations, the selector lever should be oriented as shown below (see Figure 2.3.2). To switch from HEC mode, push the selector lever all the way to the right and rotate it back until it locks in place with the green NON-HEC surface oriented up (as shown below).

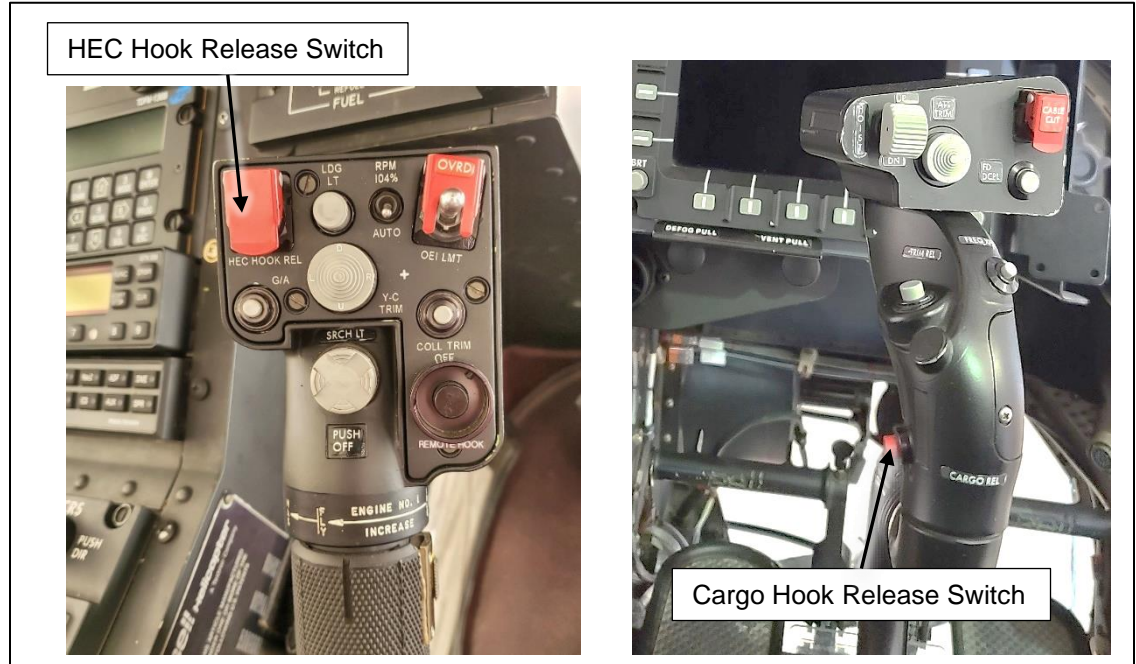
Figure 2.3.2 BQRS in NHEC Mode

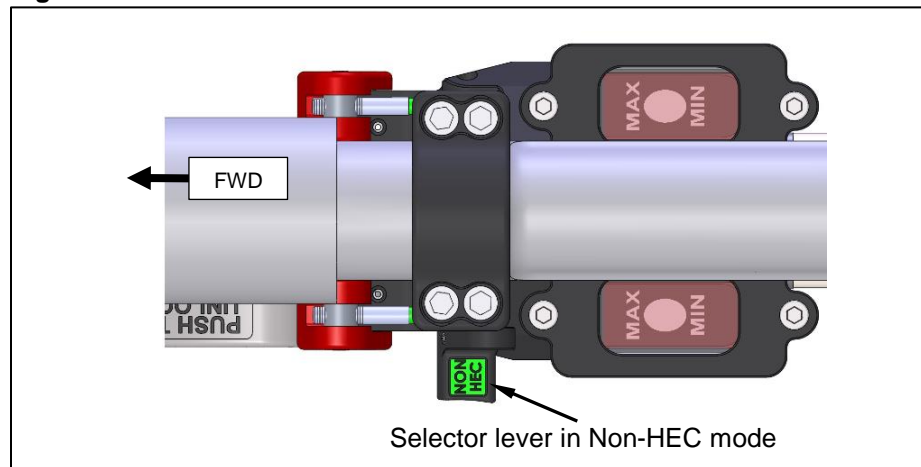

	Rotorcraft Flight Manual Supplement	Document Number 121-076-00
	Bell 429 Dual Cargo Hook System	Revision 0

For HEC operations, the orange HEC surface on the selector lever is oriented up as shown below (see Figure 2.3.3). To switch from NON-HEC to HEC, push the lever to the right, rotate it forward until it stops and allow the spring to push it outward.

Figure 2.3.3 BQRS in HEC Mode

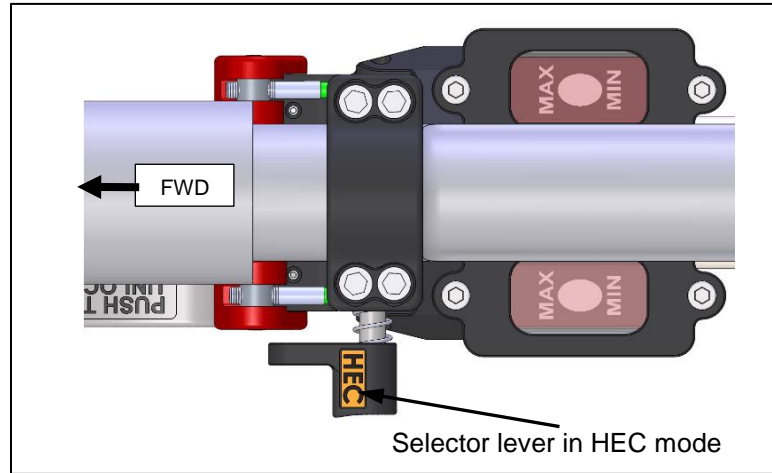

7. Check the fluid level in the master cylinder reservoir. The reservoir features a transparent lid through which the fluid level can be checked. With the collective in its lowest position, the hydraulic fluid level should be within the MIN-MAX oval (see Figure 2.3.4).

Figure 2.3.4 Fluid Level

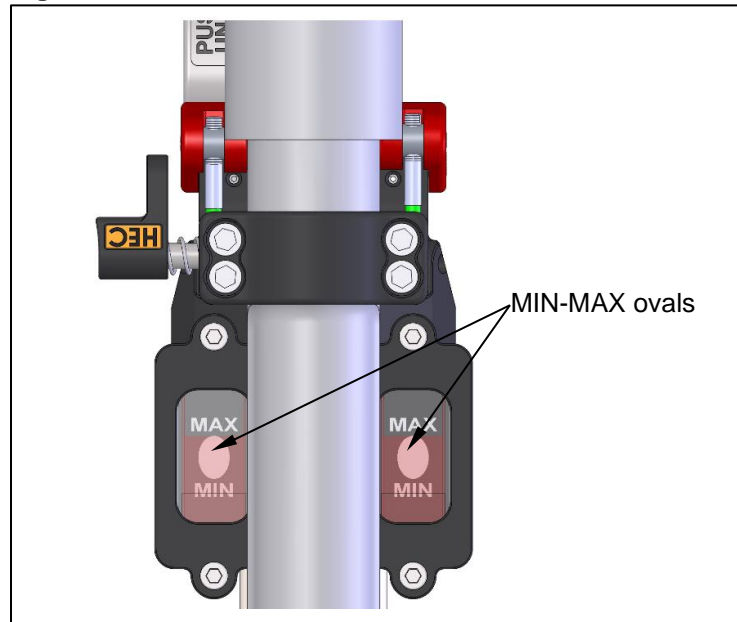

	Rotorcraft Flight Manual Supplement	Document Number 121-076-00
	Bell 429 Dual Cargo Hook System	Revision 0

8. Cycle the cargo hook’s hydraulic release systems using the release levers located on the collective. In HEC mode, the release lever operation is sequenced, requiring that the HEC HOOK RELEASE lever be actuated first, this action unlocks the CARGO HOOK RELEASE lever.
 - Disengage the Lockout Lever by pushing it down. In HEC mode, this action unlocks just the HEC HOOK RELEASE lever. In NON-HEC mode, this action unlocks both the HEC HOOK RELEASE and the CARGO HOOK RELEASE levers.
 - Pull the HEC HOOK RELEASE lever, the HEC Hook’s load beam should fall open.
 - Pull the CARGO HOOK RELEASE lever, the Cargo Hook’s load beam should fall open.

9. Check the hydraulic release system for excess air in the lines by pulling the release lever firmly until it bottoms out. Check the push rod position (see Figure 2.3.5), if some of the green ring on the push rod is visible, the system is ready for use. If none of the green ring is visible, the system needs to be bled. Refer to applicable ICA for bleed instructions.

	Rotorcraft Flight Manual Supplement	Document Number 121-076-00
	Bell 429 Dual Cargo Hook System	Revision 0

Figure 2.3.5 Checking System for Air



10. Return the Lockout Lever to the locked position, it should snap into place.
11. Return the cargo hooks to the closed and locked position by manually pushing up on the load beam. The load beam should snap shut. Verify that the hook lock indicator on the side of the hook returns to the fully locked position. In the fully locked position, the hook lock indicator should align with the lines on the cover (see Figure 2.3.6).

Figure 2.3.6 Hook Lock Indication

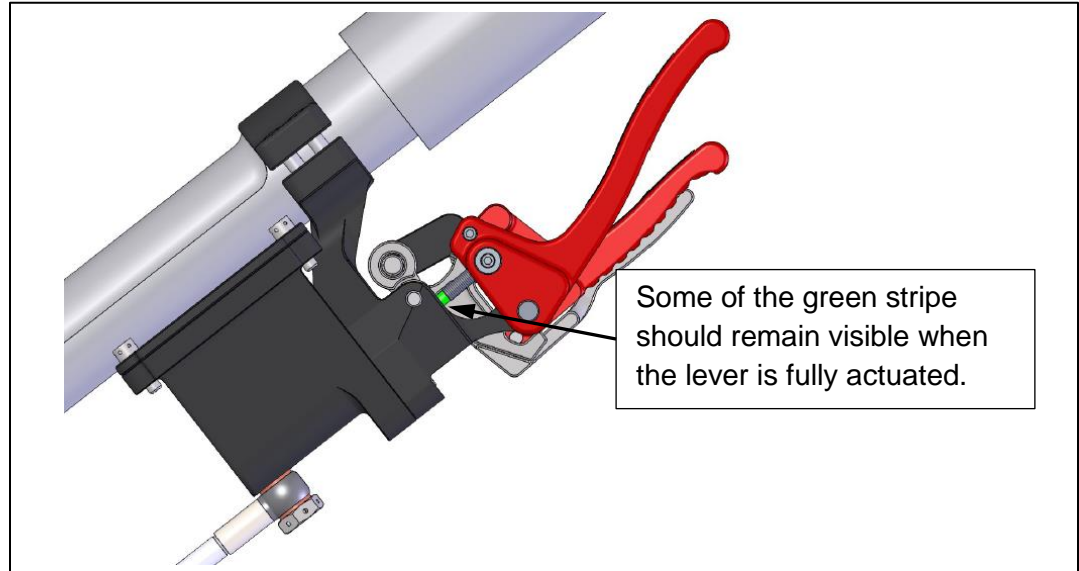
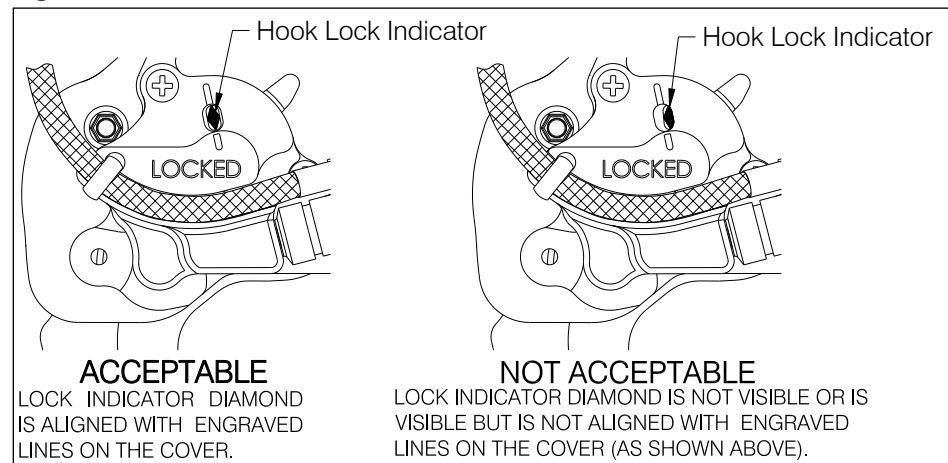

	Rotorcraft Flight Manual Supplement	Document Number 121-076-00
	Bell 429 Dual Cargo Hook System	Revision 0

If the optional load weigh system is installed, perform the following as part of the pre-flight check.

If the C-40 Indicator is not going to be used during a flight, the screen can be turned off by pressing and holding the rotary knob until the screen turns off.

12. Verify the Load Indicator displays the Load screen (shown below).
This screen is shown after power up; during power up an Information screen will display the Hook Hours, software version, and the unit's serial number (S/N).

Figure 2.3.7 Load Screen

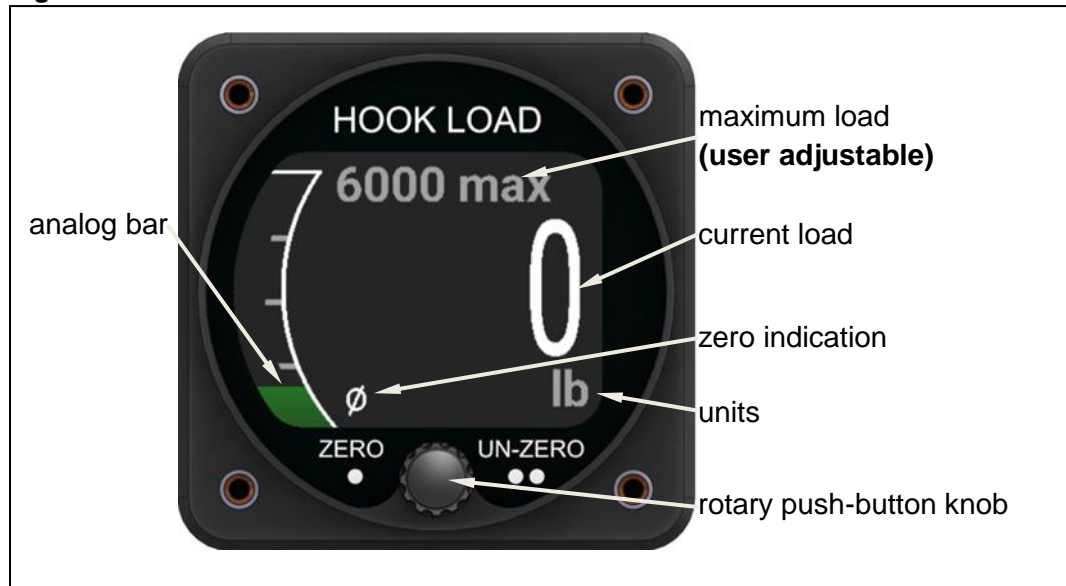

NOTICE

Refer to Owner's Manual 120-152-00 for detailed setup instructions including changing the units, changing the brightness of the display, etc. and additional operation instructions.

	Rotorcraft Flight Manual Supplement	Document Number 121-076-00
	Bell 429 Dual Cargo Hook System	Revision 0

13. Optionally set the maximum load: The C-40 Indicator includes a Maximum Load setting, this setting provides the option to select a maximum load for each flight involving external load operations based on flight conditions (temperature, altitude, fuel, etc.) or it can be set to the maximum external load rating of the rotorcraft. To set the maximum load:

- From the Load screen press and hold the rotary push button knob until the Maximum Load screen appears. Release the knob.

Figure 2.3.8 Maximum Load Screen



User adjustable maximum load (6000 shown as reference only).

- Rotate the knob to the left or right to decrease or increase the value to the desired setting.
- Press the knob to set this value.

14. To zero (or tare) the weight of the long line, net, remote hook, etc. from the displayed load, apply that weight to the cargo hook and press the knob once and the display should zero out. Press the knob twice to un-zero (un-tare) the display and add this weight back in.

NOTICE

The analog bar always displays the un-zeroed load. If there is a discrepancy between the analog bar and the displayed load, a large amount of load has likely been zeroed.

	Rotorcraft Flight Manual Supplement	Document Number 121-076-00
	Bell 429 Dual Cargo Hook System	Revision 0

2.14 Load Attachment

1. RPM switch at 104%.
2. Following attachment of the external load, slowly increase the collective pitch and ascend vertically, maintaining the rotorcraft directly above the load.
3. When the slack in the long line is removed, dwell briefly before lifting the load vertically from the surface.
4. Check the load indication on the Load Indicator.
5. Check torque required to hover with the external load.
6. Check for adequate directional control.
7. Take off into the wind, if possible, and proceed to forward climb attitude. Ensure clearance of the external load over obstacles.

Make all control movements gently with gradual acceleration and deceleration and only slightly banked turns.



Control movements should be made gently and kept to a minimum to prevent oscillation of the load and to maintain the external load angle within the limits of rotation of the cargo hook.



The cargo hook frame is designed to allow the cargo hooks to pivot and align with the external load in all directions with limits to protect the cargo hook and frame from damage. Take precautions to prevent external load angles which exceed the limits of rotation provided by the cargo hook frame as the load may not be releasable in this position.

	Rotorcraft Flight Manual Supplement	Document Number 121-076-00
	Bell 429 Dual Cargo Hook System	Revision 0

2.15 Load Release

1. RPM switch at 104% at 60 KIAS or less.
2. Verify “CARGO HK ARM” is displayed on the EICAS.
3. Perform the approach at minimum rate of descent.
4. Execute the approach to hover with sufficient height to prevent the load from hitting obstacles on or being dragged along the ground and then slowly descend vertically to set the load on the ground.

For NHEC operations:

5. Press the CARGO REL switch on the cyclic to release the external load from the cargo hook. If the Y-rope is being used and connected to both the Cargo Hook and HEC Hook, perform steps 6 and 7.

For HEC operations:

6. Press the HEC HOOK REL on the collective to release the Y-rope leg from the HEC Hook.
7. Press the CARGO REL switch on the cyclic to release the Y-rope leg from the Cargo Hook.

The CARGO HOOK RELEASE and HEC HOOK RELEASE levers on the collective may also be used to release the external load in normal circumstances.

8. Push the lockout lever down to “unlock” the release levers.
9. In HEC mode, pull the HEC HOOK RELEASE lever to release the HEC Hook and then pull the CARGO HOOK RELEASE lever. Alternately, once the HEC HOOK RELEASE lever has been pulled, it is possible to pull both levers simultaneously to release the Cargo Hook.
10. In NON-HEC mode, pull the CARGO HOOK RELEASE lever or pull both levers simultaneously to release the Cargo Hook.
11. Visually check to ensure that the external load has been released.



Verify that the external load, Y-rope and long line have dropped free from the rotorcraft before departing the drop-site.

	Rotorcraft Flight Manual Supplement	Document Number 121-076-00
	Bell 429 Dual Cargo Hook System	Revision 0

3.0 Emergency Procedures

3.13 Cargo hook fails to release electrically.

Pull the Cargo Release levers on the collective to release the external load.

1. Push the lockout lever down to “unlock” the release levers.
2. In HEC mode, pull the HEC HOOK RELEASE lever to release the HEC Hook and then pull the CARGO HOOK RELEASE lever. Alternately, once the HEC HOOK RELEASE lever has been pulled, it is possible to pull both levers simultaneously to release the Cargo Hook.

In NON-HEC mode, pull the CARGO HOOK RELEASE lever or pull both levers simultaneously to release the Cargo Hook.

4.0 Performance

The performance data in basic Flight Manual remains applicable when no external load is attached to the cargo hooks.

Refer to the basic Flight Manual for hover out of ground effect performance.

Hover and climb performance may be affected when carrying bulky loads.

The Load Weigh System is intended as a means of MONITORING the weight of the load suspended from the Cargo Hook.

Before lifting a load, it is recommended that the load weight be estimated, the shape/size is considered and, upon lifting the load, monitor the load indicator and compare the actual engine torque value vs. the expected value for a given weight to verify sufficient performance.

	Rotorcraft Flight Manual Supplement	Document Number 121-076-00
	Bell 429 Dual Cargo Hook System	Revision 0

5.0 Weight and Balance

The point of application of the external load (i.e. – primary cargo hook location) in the longitudinal direction is FS 225.0 and in the lateral direction is Y0. The HEC Hook is also at FS 225.0 and is located 9.84 inches to the right of the primary cargo hook.

The weight and CG location of the frame assembly with both cargo hooks is:

Weight	Fore/Aft CG (STA)	Lateral CG (BL)
53 lbs. (24 kg)	224.3	+1.9

NOTE: For HEC load verify the CG of the aircraft is within limits when the load is only attached to the primary Cargo Hook and also when only attached to the secondary HEC Hook.

6.0 System Description

The Dual Cargo Hook System provides the means for a Bell 429 rotorcraft to transport jettisonable NHEC and HEC loads. These kits consist of a Fixed Provisions Kit, a Removable Provisions Kit and an optional load weigh system.

6.1 Removable Provisions Kit Overview

The Removable Provisions Kits can be installed with an Onboard Systems Fixed Provisions Kit (P/N 200-485 series) or the Bell fixed provisions with modification to replace the Bell manual release cable system with the hydraulic release system.

The Removable Provisions Kits include the components external to the aircraft (ref. Figure 6.1.1 for overview) and are easily removable when a mission does not involve external loads. These kits include the cargo hook/frame assembly which includes the cargo hook and load cell, external electrical release and load cell harness, ground strap, and external hydraulic hose assembly. The structural frame assembly serves as the means to transfer the weight of the external load on the cargo hook to the hard points on the belly of the helicopter.

In addition, the Removable Provisions Kit includes an aerodynamic fairing installed just forward of the cargo hook/frame assembly.

Figure 6.1.1 Overview of Cargo Hook Frame Assembly and Fairing

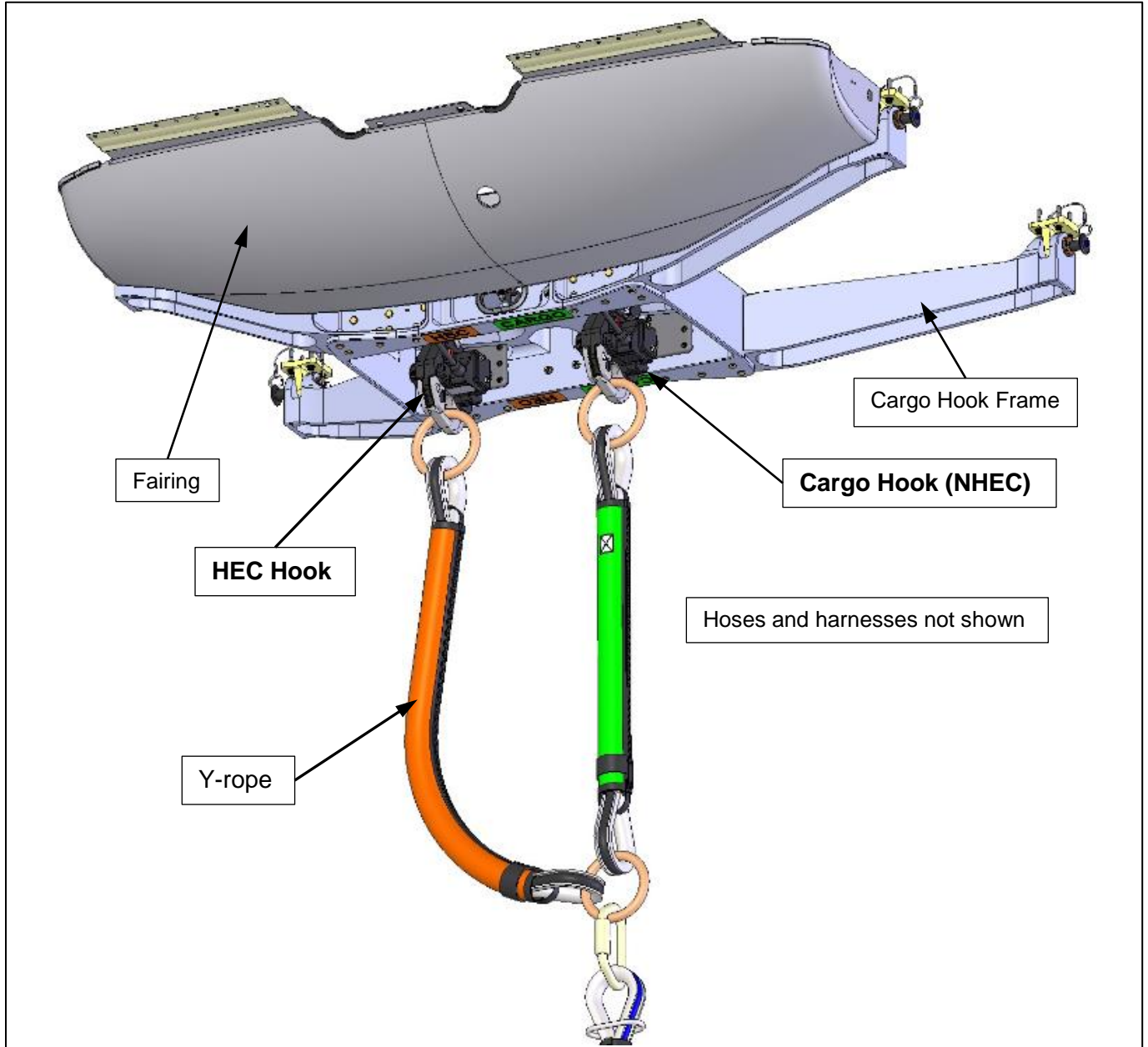

	Rotorcraft Flight Manual Supplement	Document Number 121-076-00
	Bell 429 Dual Cargo Hook System	Revision 0

6.2 Fixed Provisions Kit Overview

The Fixed Provisions Kit includes the internal components of the cargo hook electrical release system, hydraulic release system, and the optional load weigh system.

The cargo hooks' primary quick release sub-systems (PQRS) are electrical release systems. These systems use the existing type certificate (TC) installed push-button switches (ref Figure 6.2.1) on the cyclic (for the Cargo Hook) and collective (for the HEC Hook) to actuate them. The PQRS is powered on by the Arm switch in the center console.

Figure 6.2.1 Release Switches

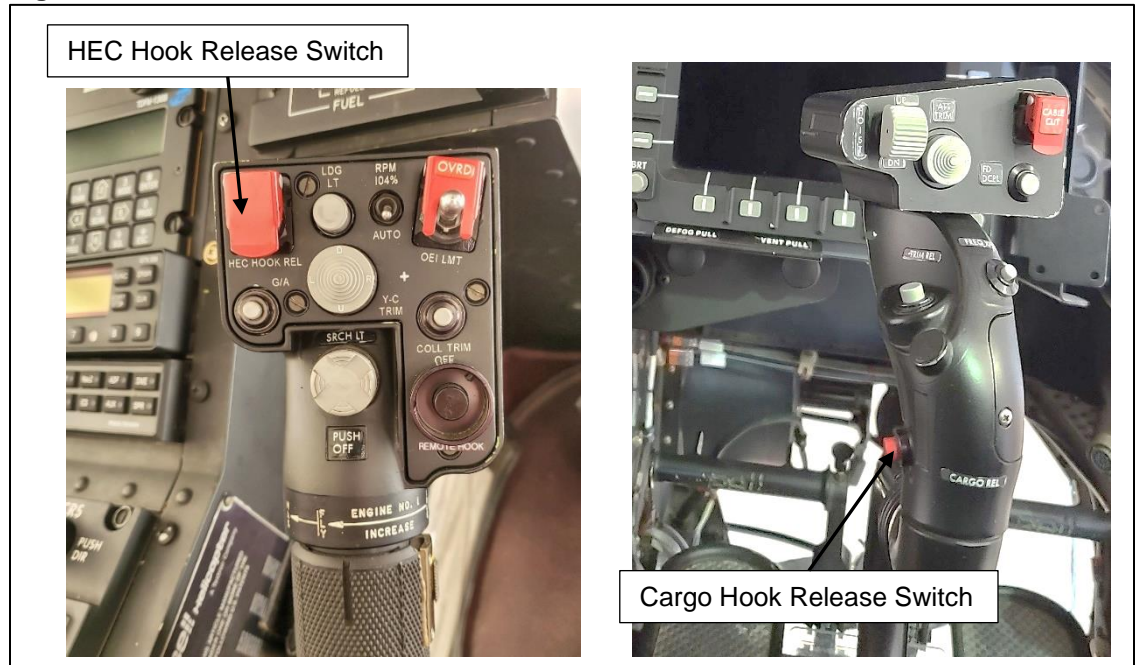

The cargo hooks' backup quick release sub-system (BQRS) are hydraulic release systems and are actuated using independent levers on the collective (ref. Figure 6.2.2).

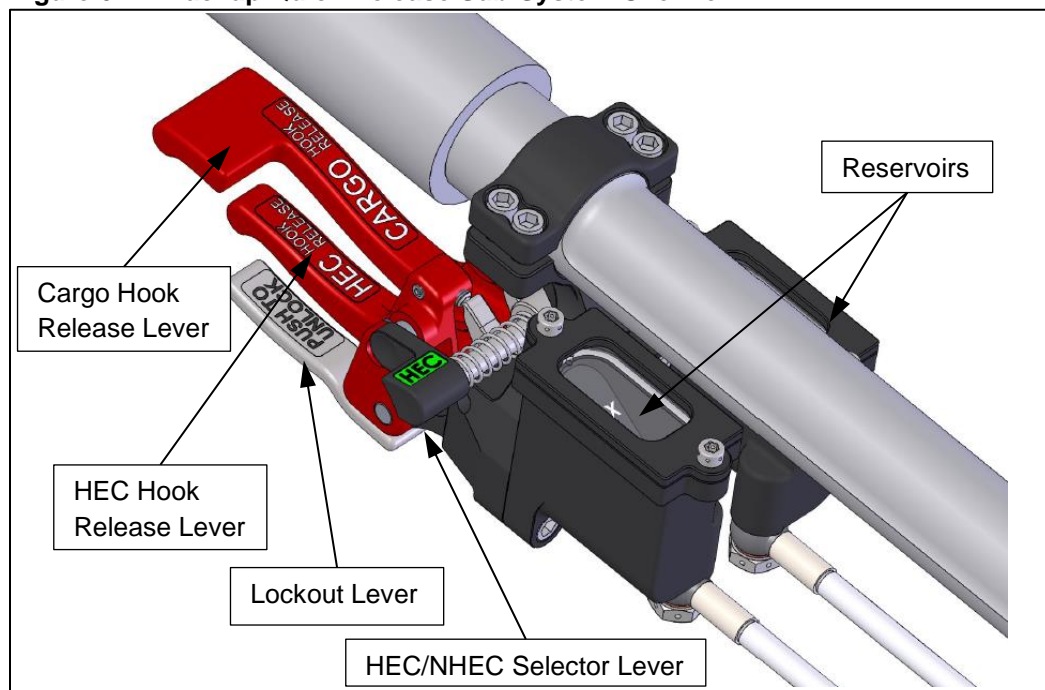
Figure 6.2.2 Backup Quick Release Sub-System Overview

The load weigh system includes the C-40 load indicator located adjacent to the door post and the load cell at the Cargo Hook and is part of the structural linkage between the Cargo Hook and the frame assembly.

The C-40 Indicator is connected to the instrument panel lighting circuit and its brightness changes with the other instruments. In addition, the relative brightness of the C-40 Indicator can be adjusted independently of the instrument panel lighting within its settings menu.