	Component Maintenance Manual	Document Number 122-002-00	Revision 19
		Date 01/14/20	Page 1 of 25

Component Maintenance Manual Cargo Hook

Onboard Systems International
13915 NW 3rd Court
Vancouver, WA 98685 United States of America
Cage Code: 1Y921

Toll Free Phone: (800) 275-0883
Phone: (360) 546-3072
Fax: (360) 546-3073

Applicable Equipment Part Numbers
528-017-00
528-017-02

[Please check our web site www.onboardsystems.com](http://www.onboardsystems.com)

for the latest revision of this manual.

	Component Maintenance Manual	Document Number 122-002-00	Revision 19
		Date 01/14/20	Page 2 of 25

RECORD OF REVISIONS

Revision	Date	Page(s)	Reason for Revision
7	09/16/08	4-1 to 4-3	Added parts list of Overhaul Kit P/N 212-017-00 to illustrated parts list.
8	02/06/09	4-2	Added 510-148-00 (Qty 3) and 510-270-00 (Qty 3) to Overhaul Kit BOM.
9	04/28/09	4-2	Added 514-017-00 (Qty 1) to Overhaul Kit BOM.
10	10/23/09	2-7	Added attach hole inspection and bushing installation instructions.
11	03/10/10	Section 2	Changed overhaul frequency criteria.
12	03/30/10	Section 1, 2-3, Section 3 Section 4	Added Rigging Warning Decal to Cargo Hook and Overhaul Kit. Updated safety labels per current standards.
13	04/27/12	All	Re-formatted manual, incorporated cargo hook P/N 528-017-02. Added Overhaul label (P/N 215-260-00) to overhaul kit (212-017-00).
14	05/08/12	10, 11, 23	Added note regarding Keeper configurations.
15	08/29/12	7, 17, 18	Clarified applicability of Onboard Systems ATP documents. Updated definition of "hours of external load operations" for clarity.
16	09/09/13	5, 6, 8	Added requirement to maintain record of all cargo hook activity (pg 5). Added Storage and Inactivity section. Added Section 6.3.
17	03/25/14	12 & 15-25	Added Cam Bearing deburr warning and Figure 9.2.
18	01/19/18	10	Remove NDT requirement for cam assembly (24), Attach Bolt (35), Cam Roller Pin (17), Cam Actuator (23) and Keeper (15).
19	01/14/20	6, 10	Replaced NDT inspection of Toggle Assembly (18) and Load Beam Assembly (29) with magnified visual inspection; moved inspection step to Table 9.1. Changed item 1 of section 4.5 to require a functional check rather than full ATP.

Register Your Products for Automatic Notifications

Onboard Systems offers a free notification service via fax or email for product alerts and documentation updates. By registering your Onboard Systems products at our website, we will be able to contact you if a service bulletin is issued, or if the documentation is updated.

You can choose to receive notices on an immediate, weekly, or monthly schedule via fax, email or both methods. There is no charge for this service. Please visit our website at www.onboardsystems.com/notify.php to get started.

	Component Maintenance Manual	Document Number 122-002-00	Revision 19
		Date 01/14/20	Page 3 of 25

1.0 Introduction

- 1.1 **Scope.** This component maintenance manual contains instructions for inspection, maintenance and overhaul.
- 1.2 **Capability.** The instructions contained in this document are provided for the benefit of experienced aircraft maintenance personnel and facilities that are capable of carrying out the procedures.
- 1.3 **Safety labels.** The following definitions apply to safety labels used in this manual.



Indicates a hazardous situation which, if not avoided, will result in death or serious injury.



Indicates a hazardous situation which, if not avoided, could result in death or serious injury.



Indicates a hazardous situation which, if not avoided, could result in minor or moderate injury.



Draws the reader's attention to important or unusual information not directly related to safety.



Used to address practices not related to personal injury.

	Component Maintenance Manual	Document Number 122-002-00	Revision 19
		Date 01/14/20	Page 4 of 25

2.0 Referenced Documents

- 180-150-00 Acceptance Test Procedure
- 180-157-00 Acceptance Test Procedure

3.0 Service Bulletins

- 3.1 This component is subject to the following service bulletins. Service bulletin documents may be obtained from the Onboard Systems website. Verify compliance with all service bulletins prior to maintenance.

Service Bulletin	Description	P/N Applicability	S/N Applicability
159-018-00	Manual Release Knob	528-017-00 528-017-02	All

	Component Maintenance Manual	Document Number 122-002-00	Revision 19
		Date 01/14/20	Page 5 of 25

4.0 Maintenance

- 4.1 Maintain a record of **ALL** cargo hook activities including aircraft installation and removal, inspections, repair and overhaul as well as inactivity and storage events.



Failure to follow all equipment maintenance instructions and component inspection criteria may result in serious injury, death or immediate loss of flight safety.

4.2 Monthly Preventative Maintenance

1. Remove accumulated soils from the exterior with a soft bristle brush and mild solvent/cleaner
2. In salt water environments, apply a corrosion preventative compound such as ACF-50 to all exterior surfaces.

4.3 Annual Inspection

1. Annually or 100 hours of external load operations, whichever comes first, remove the Cargo Hook from the aircraft. Thoroughly clean the exterior with a soft bristle brush and mild solvent/cleaner and visually inspect for cracks, gouges, dents, nicks, corrosion, and missing or loose fasteners.
2. Lubricate the Cargo Hook Attach Bolt. Recommended lubricants are Mobilgrease 28 or AeroShell 7.

4.4 Overhaul

1. Overhaul the Cargo Hook in accordance with the overhaul schedule and instructions contained here-in.

	Component Maintenance Manual	Document Number 122-002-00	Revision 19
		Date 01/14/20	Page 6 of 25

4.5 **Storage and Inactivity**

1. The cargo hook may be stored in its original factory sealed bag and box for up to 2 years from its date of manufacture or last factory overhaul. If stored in its original factory sealed bag and box for less than 2 years, it may be used without any additional activity. If the period of storage in its original packaging is greater than 2 years the cargo hook must be subjected to a functional check before being used. Perform the functional check per the instructions in section 11.8 through 11.10 of the acceptance test procedures (ATP) herein.
2. If the cargo hook has been installed on an aircraft and subsequently removed from service, store it in a reasonably protected indoor, dry, heated storage area for up to 6 months. If stored in this condition for less than 6 months, it may be used without any additional activity. If it is to be stored longer than 6 months perform the following activities. Prepare the cargo hook for storage by thoroughly cleaning and drying the exterior, liberally applying ACF-50 corrosion preventative compound inside and out, sealing it in a plastic bag with a desiccant, and labeling it with the date of storage. If stored in this condition for less than 2 years, it may be placed in service without any additional activity. If the period of storage exceeds 2 years the cargo hook must be subjected to the ATP described herein before being placed in service.
3. If the cargo hook has been installed on the aircraft and subsequently removed from service but not stored in accordance with the instructions above, the cargo hook must be subject to the ATP described herein before being placed in service.

4.6 **Repair**

1. Repair the Cargo Hook in accordance with the repair instructions contained here-in.

	Component Maintenance Manual	Document Number 122-002-00	Revision 19
		Date 01/14/20	Page 7 of 25

5.0 Repair Instructions

- 5.1 It is recommended that only minor repairs be attempted by anyone other than the factory. The following procedures and information are provided for the benefit of experienced aircraft maintenance facilities and trained maintenance and inspection personnel capable of carrying out the procedures. They must not be attempted by those lacking the necessary expertise and suitable equipment to acceptance test the cargo hook after maintenance. See Section 14, instructions for returning equipment to the factory.
- 5.2 Reference numbers throughout this manual shown in parentheses () refer to Table and Figure 13.1.
- 5.3 Follow these steps to repair the Cargo Hook, referring to the applicable sections in this manual.
1. Disassemble as required.
 2. Inspect disassembled parts.
 3. Obtain required replacement parts.
 4. Re-assemble.
 5. Acceptance test.
 6. Inspect for return to service.

	Component Maintenance Manual	Document Number 122-002-00	Revision 19
		Date 01/14/20	Page 8 of 25

6.0 Overhaul Schedule

- 6.1 The Cargo Hook shall be overhauled every 1000 hours of external load operations or 5 years, whichever comes first.
- 6.2 Hours of external load operations should be interpreted to be (1) anything is attached to the primary cargo hook (whether or not a useful load is being transported) and (2) the aircraft is flying. If these conditions are not met, time does not need to be tracked.
- 6.3 The 5 year period is from the initial installation date when the cargo hook is new or newly overhauled, regardless of storage or inactivity periods. If initial installation date is unknown, then 5 year period is from date of manufacture as indicated on the cargo hook data plate or 5 years from date of last overhaul indicated on the overhaul sticker.

7.0 Overhaul Instructions

- 7.1 It is recommended that only minor repairs be attempted by anyone other than the factory. The following procedures and information are provided for the benefit of experienced aircraft maintenance facilities and trained maintenance and inspection personnel capable of carrying out the procedures. They must not be attempted by those lacking the necessary expertise and suitable equipment to acceptance test the cargo hook after overhaul. See Section 14, instructions for returning equipment to the factory.
- 7.2 Overhaul kit P/N 212-017-00 is recommended to complete the Cargo Hook overhaul. The overhaul kit contains all recommended items to be replaced at time of overhaul. Table 13.1 lists detail parts contained in the overhaul kit.
- 7.3 Follow these steps to overhaul the Cargo Hook, referring to the applicable sections in this manual:
1. Obtain Overhaul kit P/N 212-017-00.
 2. Completely disassemble.
 3. Discard all items that are to be replaced by an item in Overhaul Kit P/N 212-017-00 listed in table 13.1 (springs, bearings, roll pins, cotter pins, fasteners except Attach Bolt (35), nuts and washers).
 4. Inspect disassembled parts.
 5. Obtain required replacement parts.
 6. Reassemble.
 7. Acceptance test.
 8. Inspect for return to service.

	Component Maintenance Manual	Document Number 122-002-00	Revision 19
		Date 01/14/20	Page 9 of 25

8.0 Disassembly Instructions

- 8.1 Cut and remove all safety wire.
- 8.2 Remove manual release cover (3) by removing cover bolts (1) and washers (2).
- 8.3 Remove nut (4), washer (5), release knob (6), and spring (7) from end of cam (24.1).
- 8.4 Remove nuts (8 and 11), and washers (9 and 12) from frame bolts. Remove the small frame bolt (12) near the attach bushings and the larger frame bolt (10) securing the bumper (14). Do not remove the remaining frame bolts at this time as they will hold the internal pieces in place during disassembly.
- 8.5 The frame can now be split by lifting the side plate (13.1) from the assembly. The internal mechanism can now be viewed and cycled to check for smooth operation. All of the internal parts may be removed at this time except the cam assembly (24) and the load beam assembly (29).
- 8.6 Remove the solenoid housing assembly by removing the solenoid bolts (19) and washers (2). For cargo hook P/N 528-017-02, the solenoid housing assembly is also connected to the side plate by the micro-switch wires. Move the solenoid housing assembly sufficiently in order to access the two screws (38) which secure the micro-switch (20.13) to the side plate.
- 8.7 The solenoid (20.8) may be removed from the cover (20.9) by removing two nuts (20.7) and two washers (20.6). Note the orientation of connector (20.4), diode (20.5) and solenoid wires. Do not typically unsolder the wires at the connector (20.4) and diode (20.5). Note the orientation of solenoid cam (20.3) and remove three screws (20.1) and washers (20.2).
- 8.8 To remove the cam assembly (24) from the side plate (30.1), first remove the cam actuator bolt (21), washer (22) and cam actuator (23). The cam assembly and o-ring (25) can now be removed.
- 8.9 To remove the load beam (29), remove bolt (21), washer (26), load beam crank (27) and load beam spring (28). The load beam assembly may now be removed.
- 8.10 Remove the attach bushings (13.4 and 30.4) by pressing them out of the side plates.
- 8.11 Bushings and bearings may be removed from detail parts by conventional means.
- 8.12 Do not typically disassemble the cam assembly (24) or toggle assembly (18).
- 8.13 Do not typically disassemble the load beam from the load beam shaft.

	Component Maintenance Manual	Document Number 122-002-00	Revision 19
		Date 01/14/20	Page 10 of 25

9.0 Inspection Instructions

- 9.1 Thoroughly clean all parts to be inspected using standard methods. Parts should be completely free of surface contaminants, soils or grease before beginning inspections.
- 9.2 If the Cargo Hook is being overhauled, firstly perform nondestructive inspection on the following parts to confirm absence of surface cracks which may have developed in service. Confirmed cracks of any size are cause for part replacement.

For the **Side Plate, Solenoid (30.1)**, and **Side Plate, Manual Release (13.1)**, inspect using:

- Liquid penetrant inspection per ASTM E1417

Mark all indications and then interpret each under 10X magnification. Differentiate surface cracks from other non-relevant indications such as machine tool marks, scratches, dents or superficial corrosion.

- 9.3 Carefully inspect detail parts in accordance with the instructions in Table 9.1. Inspect the parts in a clean, well lighted room using standard dimensional measuring tools and visual methods. Repair parts found within inspection limits. Replace any part found beyond limits.

Table 9.1, Cargo Hook Inspection Criteria

Seq	Component	Inspection Criteria & Limit	Repair Action	Finish	Recommended replacement at Overhaul
1.	Load Beam Assembly (29), Toggle Assembly (18)	Surface cracks – inspect under illuminated magnification (minimum 2X / 4 diopter).	None. Cracks of any size are cause for part replacement.	N/A	No
2.	Attach Bolt (35) Cam Actuator (23) Load Beam Assembly (29) Solenoid Cam (20.3)	Corrosion – 0.006 in. (0.127 mm) deep	Glass bead blast at less than 30 PSI (20.7 N/CM ²) to remove corrosion.	Passivate per AMS-QQ-P-35 or ASTM A967	No
3.	Side Plates (13.1), (30.1)	See Figure 9.1	Blend at 10:1 ratio as required to provide smooth transitions.	Apply alodine (MIL-DTL-5541) and zinc chromate primer (MIL-PRF-23377 or similar) to affected surfaces – see Note 1.	No
4.	Side Plates (13.1), (30.1)	Wear or deformation of top attach bushing hole ID – 0.6285 in (15.96 mm)	None	N/A	No



Component Maintenance Manual

Document Number
122-002-00

Revision
19

Date
01/14/20

Page
11 of 25

Seq	Component	Inspection Criteria & Limit	Repair Action	Finish	Recommended replacement at Overhaul
5.	Manual Release Cover (3) Solenoid Cover (20.9)	Dents, nicks, cracks, gouges, scratches and corrosion – 0.020 in. (0.50 mm) deep	Blend at 10:1 ratio as required to provide smooth transitions.	Apply alodine (MIL-DTL-5541) and zinc chromate primer (MIL-PRF-23377 or similar) to affected surfaces – see Note 1.	No
6.	Attach bolt (35)	Wear on OD – 0.495 in. (12.57 mm)	None	N/A	No
7.	Bushing (13.2), (30.2)	Wear – more than 50% copper showing	None	N/A	Yes
8.	Bearing (13.3), (18.2), (30.3)	Roughness, binding, looseness, or corrosion	None	N/A	Yes
9.	Attach Bushing (13.4), (30.4)	Wear on ID – 0.520 in (13.208 mm)	None	N/A	Yes
10.	Bumper (14)	Denting, cuts or abrasions – 0.060 in. (1.27 mm) deep	None	N/A	Yes
11.	Keeper or Keeper Assembly (15) – see Note 2.	Gouges and nicks – 0.050 in. (1.27 mm) deep.	Blend at 10:1 ratio as required to provide smooth transitions.	Passivate per AMS-QQ-P-35 or ASTM A967. For Keeper Assembly, apply Alodine (MIL-DTL-5541) and zinc chromate primer (MIL-PRF-23377 or similar) to affected surfaces – see Note 1.	No
12.	Keeper or Keeper Assembly (15)	Bending or deformation between keeper ears, 0.772 in (19.6 mm) ± 0.200 in. (5.08 mm)	Straighten to 0.772 in. (19.6 mm) outside width dimension.	N/A	No
13.	Cam Assembly (24)	See figure 9.2	None	N/A	No
14.	Cam Assembly (24)	Roughness, binding or looseness of the Interlock Roller (24.5)	Replace Interlock Pin (24.4) and Roller (24.5)	N/A	No
15.	Toggle Assembly (18)	Roughness, binding or looseness of the Load Beam Roller (18.4).	None	N/A	No

	Component Maintenance Manual	Document Number 122-002-00	Revision 19
		Date 01/14/20	Page 12 of 25

Seq	Component	Inspection Criteria & Limit	Repair Action	Finish	Recommended replacement at Overhaul
16.	Cam roller pin (17)	Visible denting, corrosion	None	N/A	No
17.	Load Beam (29.1)	Wear, gouges and nicks – 0.050 in. (1.27 mm) deep.	Blend at 10:1 ratio to provide smooth transitions and ensure load rings will not hang up during release.	Passivate per AMS-QQ-P-35 or ASTM A967.	No
18.	Serial number decal (36)	Damaged or illegible.	None	N/A	Yes
19.	Load beam crank (27)	Wear in spring groove - 0.030 in (0.762 mm).	None	N/A	No
20.	Solenoid (20.8)	Shorted or open electrical circuit. For Cargo Hook P/N 528-017-00, resistance 2 to 2.5 ohms. For Cargo Hook P/N 528-017-02, resistance 3.0 to 4.0 ohms.	None	N/A	No
21.	Electrical connector (20.4)	Loose, missing, or mutilated contact pins, cracked case, or worn insulator	None	N/A	No
22.	Load ring warning decal (37)	Damaged or illegible	None	N/A	Yes
23.	Rigging Warning Decal (39)	Damaged or illegible	None	N/A	Yes
24.	Springs (7, 24.3, and 28)	Cracks or deformations	None	N/A	Yes
25.	Electrical Wiring	Deterioration	Replace	N/A	No
26.	All remaining nuts, bolts, roll pins, cotter pins, washers, heli-coils	Wear, corrosion or deterioration	None	N/A	Yes

Note 1 – For service at Onboard Systems, optional finish - black anodize per MIL-A-8625 Type II, Class 2 after nondestructive inspection. Prepare for anodize by using standard methods.

Note 2 – The Keeper is a one-piece stainless steel design which supersedes the Keeper Assembly configuration which is a two piece aluminum design.

Figure 9.1, Side Plate, Additional Inspection Criteria

Side Plate, Solenoid (30.1)

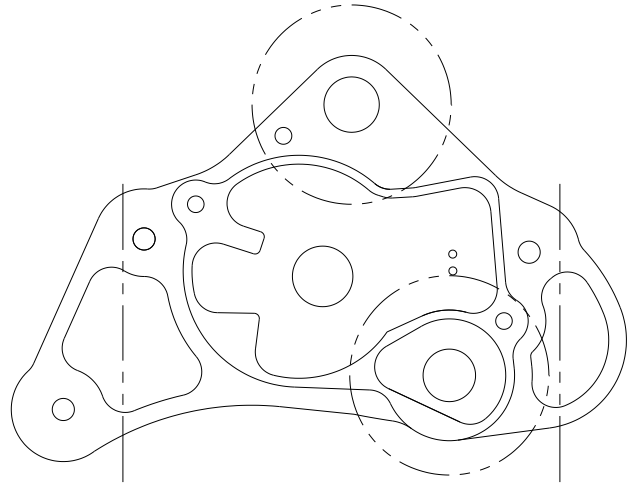
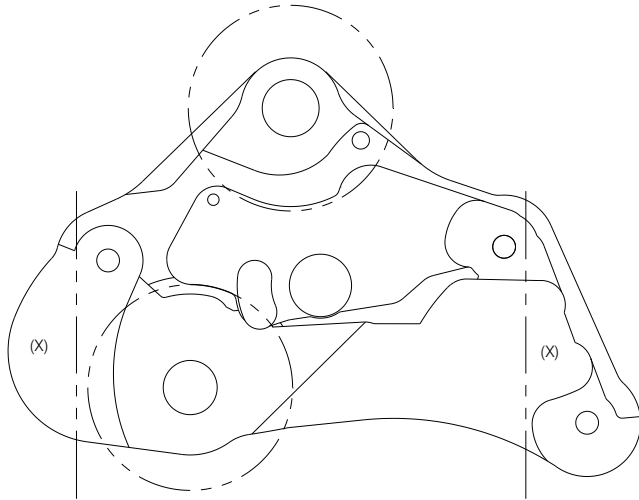

Side Plate, Manual (13.1)

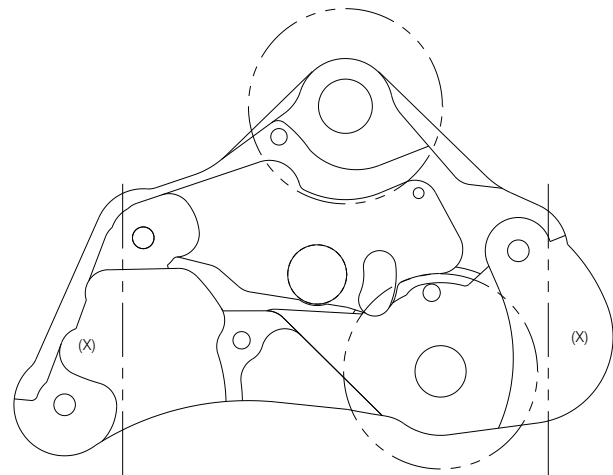
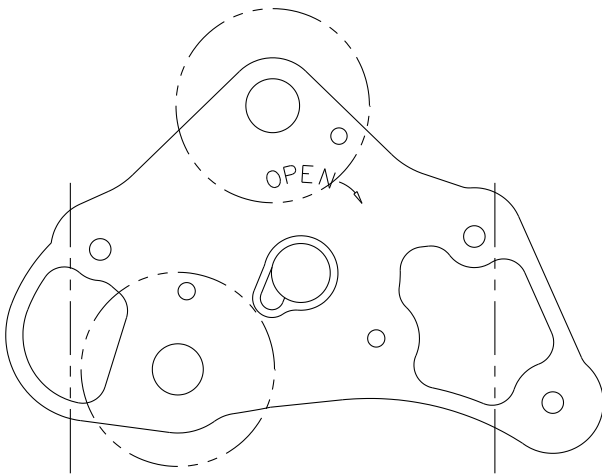

Inspection Criteria and Limits

Inside dashed circles – NO corrosion allowed.

Inside dashed circles – Dents, nicks, gouges, and scratches – 0.005 in (0.13 mm) deep.

Inside dashed lines – Dents, nicks, gouges, scratches, and corrosion – 0.010 in (0.25 mm) deep.

Outside dashed lines – Dents, nicks, gouges, scratches, and corrosion – 0.020 in (0.50 mm) deep.

(X) Approved metal stamp locations

	<p style="text-align: center;">Component Maintenance Manual</p>	Document Number 122-002-00	Revision 19
		Date 01/14/20	Page 14 of 25

Figure 9.2, Cam Assembly (24) Bearing Inspection Criteria



Inspection Criteria and Limits:
 Inside Lines: No wear, dents, corrosion, gouges or nicks allowed.



Thoroughly inspect surfaces inside lines for signs of visible wear, dents, corrosion, gouges or nicks. Continued use of a damaged cam *may cause inadvertent load release.*



Repair (including filing, deburring and buffing) is prohibited on all surfaces shown inside lines. Alterations of these surfaces may cause inadvertent load release.

	Component Maintenance Manual	Document Number 122-002-00	Revision 19
		Date 01/14/20	Page 15 of 25

10.0 Re-assembly Instructions

- 10.1 Replace all parts found to be unserviceable or beyond limits.
- 10.2 Measure the top attach bushing hole of side plates (13.1) and (30.1) with a bore gage to determine if the standard attach bushing (13.4, 30.4) is appropriate or if an oversized attach bushing P/N 290-294-01 is required. The oversized attach bushing P/N 290-294-01 may be distinguished from the standard attach bushing by the presence of a groove on the OD.
- 10.3 Install attach bushing into side plates as follows.

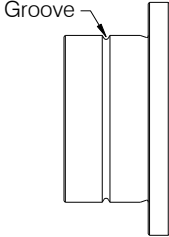
If top attach hole measures:	Use attach bushing:	Installation
Less than .6257 in (15.893 mm) .6264 - .6270 in (15.910 – 15.926 mm)	P/N 290-294-00 P/N 290-294-01* * Oversized Attach Bushing P/N 290-294-01 is identified by a groove on its OD as shown. 	Install with wet zinc chromate primer using an arbor press. Ensure a continuous fillet seal of primer around bushing flange after installation.
.6257 - .6263 in (15.893 – 15.908 mm) .6271 - .6285 in (15.928 – 15.954 mm)	P/N 290-294-00 P/N 290-294-01	Install with Loctite 680 adhesive using an arbor press. Ensure a continuous fillet seal of adhesive around bushing flange after installation.

- 10.4 Install bearings (13.3, 30.3) and bushings (13.2, 30.2) with an arbor press.
- 10.5 If cam was disassembled, install interlock roller (24.5) and pin (24.4) and stake body of cam around pin hole.
- 10.6 Install the load beam assembly (29) into the side plate (30.1) and attach the load beam spring (28), load beam crank (27), washer (26), and bolt (21). When installing the spring and load beam crank, pre-load the spring approximately 90 degrees. Apply Loctite 242 to bolt and torque to 20-25 in-lbs. Secure bolt with safety wire to the hole in the load beam crank.

	Component Maintenance Manual	Document Number 122-002-00	Revision 19
		Date 01/14/20	Page 16 of 25

- 10.7 Install cam assembly (24) in side plate (30.1). Grease needle bearings (13.3, 30.3) and o-ring (25) prior to assembly with MIL-PRF-23827 grease. Install cam actuator (23), bolt (21) and washer (22). Apply Loctite 242 to bolt and torque to 20-25 in-lbs. Safety wire bolt to hole in cam actuator, taking care to tuck excess safety wire under cam actuator to avoid interference with the solenoid.
- 10.8 If the solenoid was removed, re-install it in the solenoid cover (20.9). Apply sealant around threads of solenoid mounting studs from the outside prior to installation of washers (20.6) and nuts (20.7). Sealant on the inside can foul the return spring on the solenoid. If the diode was removed, re-install it in the same orientation and polarity before removal. See Table 1-2 for connector polarity and diode caution note. Torque the solenoid nuts (20.7) to 20-25 in-lbs.
- 10.9 Apply sealant (Loctite 598) to faying surfaces prior to assembly and install solenoid cover onto side plate with bolts (19) and washer (2). For P/N 528-017-02, initially position the solenoid cover near to the side plate in order to attach the micro-switch (20.13) to the side plate with screws (38). If necessary clear sealant from drain slot in cover adjacent to load beam shaft. Torque solenoid cover bolts (19) to 20-25 in-lbs.
- 10.10 Insert bolts (10) through side plate (30.1).
- 10.11 Grease needle bearing (18.2) with MIL-PRF-23827 grease and install toggle assembly (18) into side plate (30.1) needle bearing. Insert cam roller pin (17) into toggle assembly needle bearing. If pin (18.3) has been disassembled, stake in place with a center punch.
- 10.12 Install Keeper (15) and spring (16) into bolt (10). Spring should have approximately 120 degrees of pre-load.
- 10.13 Check for and remove FOD, if present.
- 10.14 Place the bumper into the side plate (30.1). Install the side plate assembly (13) over the assembly assuring the mechanism functions freely. Install the bolts (10) through the side plate. On the bolts (10) install washers (9) and nuts (8). Torque nuts (8) to 50-70 in-lbs. Also install bolt (12), washer (2), and nut (11). Torque nut (11) to 30-35 in-lbs.
- 10.15 Install spring (7), release knob (6), washer (5), and nut (4) onto end of cam. Pre-load spring approximately 360 degrees when assembling. Torque to 30-35 in-lbs and bend up tab on washer.
- 10.16 Check for and remove FOD if present.
- 10.17 Install manual release cover (3) with bolts (1) and washers (2). Torque bolts to 30-35 in-lbs.
- 10.18 Safety wire all cover bolts.
- 10.19 If S/N decal (36) is new, stamp applicable information.
- 10.20 Install attach bolt (35), washers (34), washer (33), and nut (32). Loosely install cotter pin (31).

	Component Maintenance Manual	Document Number 122-002-00	Revision 19
		Date 01/14/20	Page 17 of 25

- 10.21 If load ring warning decal (37) is new, install onto bottom of solenoid cover (20.9). If rigging warning decal (39) is new, also install onto bottom of solenoid cover.
- 10.22 Perform the acceptance test procedure per this manual.
- 10.23 Fill out and affix Overhaul Label (P/N 215-260-00).

	Component Maintenance Manual	Document Number 122-002-00	Revision 19
		Date 01/14/20	Page 18 of 25

11.0 Acceptance Test Procedure

- 11.1 When Cargo Hook is overhauled or the side plates (13.1 and 30.1) are separated, the Cargo Hook must be subjected to the following acceptance test procedure (ATP) before being returned to service.
- 11.2 Examine the cargo hook externally for security of the lock wire, cotter pins and fasteners.
- 11.3 Use an appropriate insulation resistance tester to test the resistance between each pin and the base of the connector (2.6). The readings should not be less than 2 mega-ohms.
- 11.4 Using a multi-meter, check the resistance between pins A and B of the electrical connector. Resistance should be:

Applicable P/Ns	Resistance
528-017-00	2 – 2.5 ohms
528-017-02	3 – 4 ohms

- 11.5 For Cargo Hook P/N 528-017-02, test the continuity between pins A and C of connector (20.4). With the Load Beam (29) in the closed position, the resistance should be infinite. With the Load Beam in the open position, the resistance should be zero.
- 11.6 Remove the Manual Release Cover (3) by removing two screws (1) and washers (2) and install a manual release test cable. Re-install the Manual Release Cover and screws.
- 11.7 Suspend the hook from a test rig capable of loading the cargo hook to 8,750 lbs (3968 KG). Use a steel ring to apply the load to the load beam.
- 11.8 Connect an adjustable 20 – 28 VDC supply with a momentary release switch wired into the positive wire, to the connector (20.4), and an in-line current meter. Connect the negative lead to pin A and the positive lead to pin B. Set the voltage to 20± 0.1VDC:
- 11.9 Attach a 10 pound (4.5 KG) weight to the load beam. Operate the manual release lever. The load beam should unlatch and the load should slide off the load beam. Release the manual release lever. Ensure that the load beam returns to the fully locked position.
- 11.10 Attach the 10 lb (4.5 KG) weight to the load beam. Operate the electrical release. The load beam should unlatch and the load should slide off the load beam. Ensure that the load beam returns to the fully locked position.

CAUTION

Damage to the cargo hook release solenoid can occur if the electrical release switch is operated for more than 20 seconds continuously.

	Component Maintenance Manual	Document Number 122-002-00	Revision 19
		Date 01/14/20	Page 19 of 25

- 11.11 Load a suitable load ring onto the load beam (6). Gradually proof-load the cargo hook with the test rig to the load in the table below. Hold the load for 1 minute. The load beam should hold the load without unlatching. Reduce the load to zero.

Applicable P/Ns	Proof Load
528-017-00	8,750 lbs (3,969 KG)
528-017-02	6,875 lbs (3,118 KG)



Do not release the proof test load electrically or manually. Decrease the load gradually, using the test machine, after completion of the proof load test.

- 11.12 Load the cargo hook using a steel ring that is free to drop clear of the load beam and allow it to re-latch. Gradually load the cargo hook to 3,500 lbs (1587 KG) or 2,750 lbs (1247 KG) if testing P/N 528-017-02. Using a spring scale or equivalent, pull the manual release cable. The load beam should unlatch and the steel ring should slide off the load beam. The load beam should automatically re-latch after the release. Verify the required release force is between 3.5 lbs (1.58 KG) and 8 lbs (3.62 KG). Repeat the test at 2000 lbs (907 KG), 600 lbs (272 KG) and 7 lbs (3.18 KG).
- 11.13 Load the cargo hook using a steel ring that is free to drop clear of the load beam and allow it to re-latch. Gradually load the cargo hook to 3,500 lbs (1,587 KG) or 2,750 lbs (1,247 KG) if testing P/N 528-017-02. Press the electrical release button. The load beam should unlatch and the steel ring should slide off the load beam. The load beam should automatically re-latch after the release. Verify that the current draw is between 9 and 11 amps for P/N 528-017-00 or between 6 and 8 amps for P/N 528-017-02. Repeat the test at 2,000 lbs (907 KG), 600 lbs (272 KG) and 7 lbs (3.18 KG).
- 11.14 Remove the Cargo Hook from the test stand. Remove the manual release cable and re-install the Manual Release Cover (3) with screws (1) and washers (2).
- 11.15 End of Acceptance Test Procedure.
- 11.16 For service at Onboard Systems, optionally use the following Onboard Systems factory acceptance test procedures:

Acceptance Test Procedure	Applicable P/Ns
180-150-00	528-017-00
180-157-00	528-017-02

	Component Maintenance Manual	Document Number 122-002-00	Revision 19
		Date 01/14/20	Page 20 of 25

12.0 Troubleshooting

12.1 The following section lists symptoms and probable causes to aid in equipment troubleshooting.

Symptom	Probable Cause	Remedy
Cargo Hook does not operate electrically.	Damaged or defective diode (20.5) or solenoid (20.8).	Check for proper resistance across connector pins A and B per section 11.4. If out of tolerance, remove the Solenoid Assembly (20) and disconnect the diode (20.5). Re-check for proper resistance. Replace diode (20.5) or solenoid (20.8) as necessary.
	Damaged or loose wiring.	Check for proper continuity across connector pins A & B per table 9.1 seq. 20. Remove the Solenoid Assembly (20) and repair wiring.
During the Acceptance Test Procedure, the manual release cable force exceeds requirements.	Friction in internal mechanism.	Check operation of unit using the manual release lever. Disassemble and inspect internal mechanism. Check all bearing joints for free movement. Check cam assembly (24) for denting/ damage. Check toggle roller and pin for denting/ damage. Replace as necessary.

13.0 Illustrated Parts List

Figure 13.1, Cargo Hook Parts

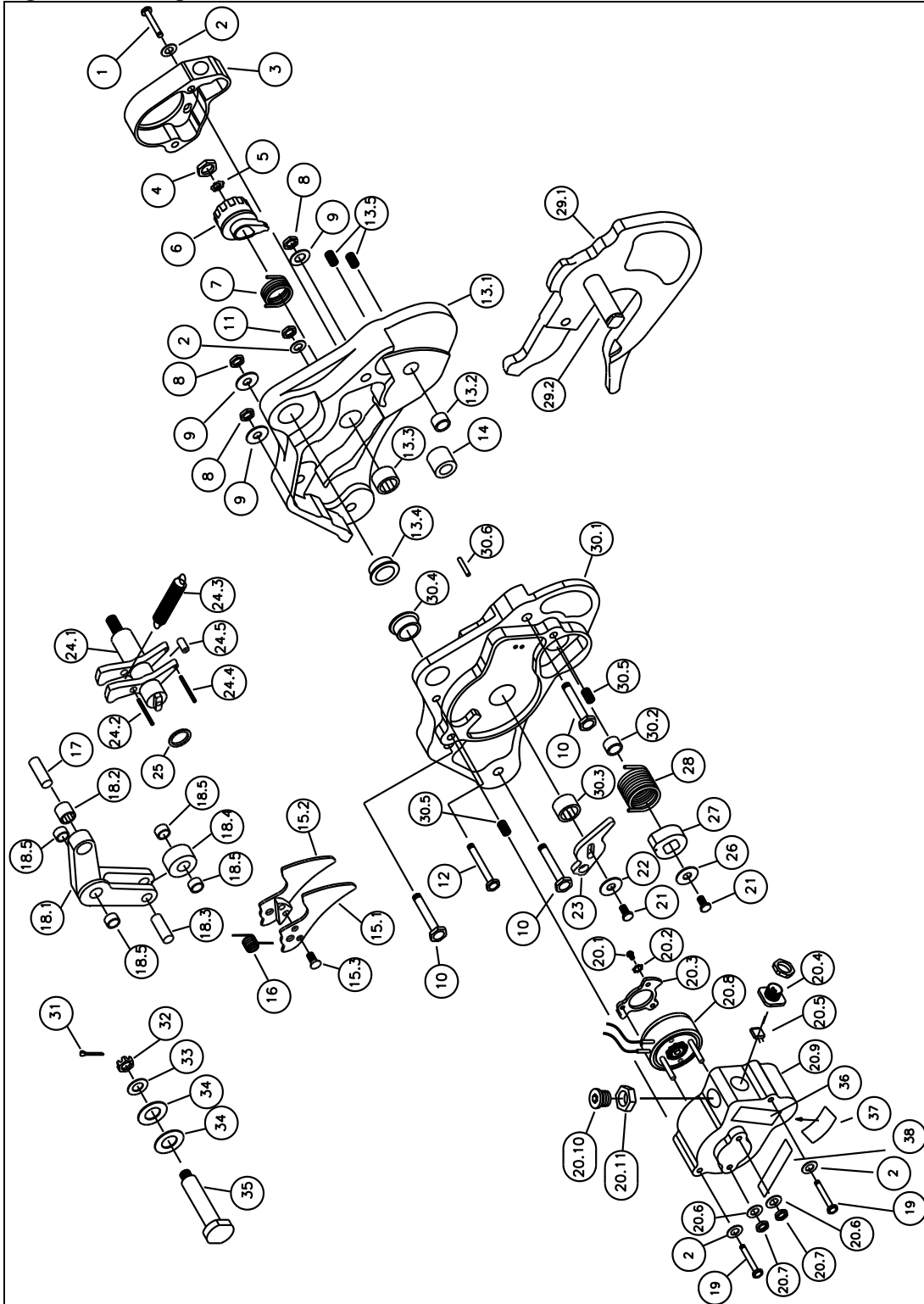

	Component Maintenance Manual	Document Number 122-002-00	Revision 19
		Date 01/14/20	Page 22 of 25

Table 13.1, Cargo Hook Parts

Item	Part No.	Description	Qty in 528-017-XX		Qty in Overhaul Kit P/N P/N 212-017-00
			-00	-02	
1	510-253-00	Bolt	2	2	2
2	510-095-00	Washer	5	5	5
3	290-473-01	Manual Release Cover	1	1	-
4	510-246-00	Nut	1	1	1
5	510-271-00	Washer	1	1	1
6	290-471-02	Release Knob	1	1	-
7	514-013-00	Cam Spring	1	1	1
8	510-114-00	Nut	3	3	3
9	510-100-00	Washer	3	3	3
10	510-284-00	Bolt	3	3	3
11	510-102-00	Nut	1	1	1
12	510-283-00	Bolt	1	1	1
13 ¹	232-055-01	Side Plate Assembly- Manual Release	1	1	-
13.1	290-470-01	Side Plate, Manual Release	1	1	-
13.2	517-023-00	Load Beam Pivot Bearing	1	1	1
13.3	517-020-00	Cam Shaft Bearing	1	1	1
13.4 ³	290-294-00	Attach Bushing	1	1	1
13.5	510-248-00	Helicoil	4	4	4
14	514-017-00	Beam Bumper	1	1	-
15 ⁴	291-233-00 or 232-057-01	Keeper or Keeper Assembly	1	1	-
15.1	290-474-01	Keeper Half	1	1	-
15.2	290-475-01	Keeper Half	1	1	-
15.3	510-164-00	Flathead Screw	2	2	2
16	514-014-00	Keeper Return Spring	1	1	1
17	290-439-00	Cam Roller Pin	1	1	-
18 ¹	232-059-02	Toggle Assembly	1	1	-
18.1	290-435-02	Toggle	1	1	-
18.2	517-019-00	Cam Roller Bearing	1	1	1
18.3	290-440-00	Pin, Load Beam Roller	1	1	-
18.4	290-438-00	Load Beam Roller	1	1	-
18.5	517-021-00	Toggle Roller Bearing	4	4	2
19	510-267-00	Bolt	2	2	2

	Component Maintenance Manual	Document Number 122-002-00	Revision 19
		Date 01/14/20	Page 23 of 25

Table 13.1, Cargo Hook Parts continued

Item	Part No.	Description	Qty in 528-017-XX		Qty in Overhaul Kit P/N P/N 212-017-00
			-00	-02	
20 ¹	232-060-03	Solenoid Housing Assembly	1	-	-
20 ¹	232-060-05	Solenoid Housing Assembly	-	1	-
20.1	510-148-00	Screw	3	3	-
20.2	510-270-00	External Star Washer	3	3	-
20.3	290-445-00	Solenoid Cam	1	1	-
20.4	410-139-00	Connector	1	1	-
-	556-045-00	O-Ring	-	-	1
20.5	340-035-00	Diode	1	1	-
20.6	510-095-00	Washer	2	2	2
20.7	510-043-00	Nut	2	2	2
20.8	455-005-00	Solenoid	1	1	-
20.9	290-468-01	Solenoid Cover	1	1	-
20.10	510-359-00	Plug	1	1	-
20.11	510-360-00	Nut	1	1	-
20.12	420-055-00	Wire	-	2	-
20.13	400-047-00	Switch	-	1	-
21	510-257-00	Bolt	2	2	2
22	510-042-00	Washer	1	1	1
23	290-444-00	Cam Actuator	1	-	-
23	290-444-01	Cam Actuator	-	1	-
24 ¹	232-058-00	Cam Assembly	1	1	-
24.1	290-443-00	Cam	1	1	-
24.2	510-272-00	Roll Pin - Cam	1	1	-
24.3	514-015-00	Cam Backup Spring	1	1	1
24.4	290-450-00	Interlock Pin	1	1	-
24.5	290-308-00	Interlock Roller	1	1	-
25	556-030-00	O-Ring	1	1	1
26	510-085-00	Washer	1	1	1
27	290-452-01	Load Beam Crank	1	1	-
28	514-016-00	Load Beam Spring	1	1	1
29 ²	232-054-01	Load Beam Assembly	1	1	-

	Component Maintenance Manual	Document Number 122-002-00	Revision 19
		Date 01/14/20	Page 24 of 25

Table 13.1, Cargo Hook Parts continued

Item	Part No.	Description	Qty in 528-017-XX		Qty in Overhaul Kit P/N P/N 212-017-00
			-00	-02	
30 ¹	232-056-01	Side Plate Assembly-Solenoid	1	1	-
30.1	290-469-01	Side Plate, Solenoid	1	1	-
30.2	517-023-00	Load Beam Pivot Bearing	1	1	1
30.3	517-020-00	Cam Shaft Bearing	1	1	1
30.4 ³	290-294-00	Attach Bushing	1	1	1
30.5	510-248-00	Helicoil	4	4	-
30.6	510-249-00	Roll Pin-Housing	1	1	1
31	510-178-00	Cotter Pin	1	1	1
32	510-170-00	Nut	1	1	1
33	510-174-00	Washer	1	1	1
34	510-183-00	Washer	2	2	2
35	290-332-00	Attach Bolt	1	1	-
36	215-077-00	S/N Decal	1	-	1
36	215-125-00	S/N Decal	-	1	1
37	215-109-00	Ring Limits Decal	1	1	1
38	510-364-00	Screw	-	2	-
39	215-240-00	Rigging Warning Decal	1	1	1
40	215-260-00	Overhaul Label	-	-	1

NOTICE

1 Item not illustrated as an assembly.

2 P/N 232-054-01 supersedes P/N 232-054-00. P/N 232-054-00 optional.

3 Optionally P/N 290-294-01 may be used, see Table 2-4.

4 Keeper Assembly P/N 232-057-01 has been superseded by Keeper P/N 291-233-00 (a one piece design), P/N 232-057-01 is optional. Items 15.1, 15.2 & 15.3 are only applicable if P/N 232-057-01 is installed.

	Component Maintenance Manual	Document Number 122-002-00	Revision 19
		Date 01/14/20	Page 25 of 25

14.0 Instructions for Returning Equipment to the Factory

- 14.1 If an Onboard Systems product must be returned to the factory for any reason (including returns, service, repairs, overhaul, etc.) obtain an RMA number before shipping your return.



An RMA number is required for all equipment returns.

- To obtain an RMA, please use one of the listed methods.
 - Contact Technical Support by phone or e-mail (Techhelp@OnboardSystems.com).
 - Generate an RMA number at our website: <http://www.onboardsystems.com/rma.php>
- After you have obtained the RMA number, please be sure to:
 - Package the component carefully to ensure safe transit.
 - Write the RMA number on the outside of the box or on the mailing label.
 - Include the RMA number and reason for the return on your purchase or work order.
 - Include your name, address, phone and fax number and email (as applicable).
 - Return the components freight, cartage, insurance and customs prepaid to:

Onboard Systems
13915 NW 3rd Court
Vancouver, Washington 98685
USA
Phone: 360-546-3072