

**PLEASE CHECK WEB SITE AT WWW.ONBOARDSYSTEMS.COM FOR
THE LATEST REVISION OF THIS MANUAL**

**Instructions for
Continued Airworthiness
Talon LC Keeperless
Cargo Hook Kit
For the
AS350 Series**

**System Part Number
200-261-00**

STC SR00886SE



13915 NW 3rd Court Vancouver Washington 98685 USA
Phone: 360-546-3072 Fax: 360-546-3073 Toll Free: 800-275-0883
www.OnboardSystems.com

THIS PAGE INTENTIONALLY LEFT BLANK

RECORD OF REVISIONS

<i>Revision</i>	<i>Date</i>	<i>Page(s)</i>	<i>Reason for Revision</i>
1	9/17/02	Title	Factory address change.
2	10/10/03	00-00-00 Page 1 00-00-00 Page 2 05-00-00 Page 1 25-00-00 Page 2 25-00-00 Page 4	528-023-01 cargo hook configuration change Reference Service Bulletin 159-011-00
3	02/12/04	00-00-00 Page 2	Added EC130 B4 to applicability list
4	03/26/07	Section 0 Section 5 Section 25 pages 1, 2, 4, and 6.	Added Section 0.12 to add Warnings, Cautions, and Notes and their explanations. Updated Section 5 to include daily check, an annual inspection, and update cargo hook overhaul frequency criteria. Re-formatted Caution and Note statements, added kgs to Table 25-2. Revised torque instructions for nut on page 4 and updated Figure 25-2 including p/n's.
5	08/11/09	25-00-00, Page 5	Added caution note and revised figure 25-3
6	03/10/10	05-00-00 Page 3 and 4 25-00-00 Page 5	Changed overhaul frequency criteria. Clarified manual release cable connection instructions.
7	03/26/14	Section 0 Section 5 Section 25	Updated definition of external load operations, updated safety label format, removed daily check. Updated Section 0.19. Referenced Cargo Hook CMM where applicable.

Register Your Products for Automatic Notifications

Onboard Systems offers a free notification service via fax or email for product alerts and documentation updates. By registering your Onboard Systems products at our website, we will be able to contact you if a service bulletin is issued, or if the documentation is updated.

You can choose to receive notices on an immediate, weekly, or monthly schedule via fax, email or both methods. There is no charge for this service. Please visit our website at www.onboardsystems.com/notify.php to get started.

THIS PAGE INTENTIONALLY LEFT BLANK

List of Effective Pages

Title	Pages	Revision	Date
Cover	<i>i, ii</i> Blank	7	03/26/14
Record of Revision	<i>iii, iv</i> Blank	7	03/26/14
List of Effective Pages	<i>v, vi</i> Blank	7	03/26/14
Table of Contents	<i>vii, viii</i> Blank	7	03/26/14
Section 0 Introduction 00-00-00	1, 2	7	03/26/14
Section 4 Airworthiness Limitations 04-00-00	1, 2 Blank	0	11/13/00
Section 5 Inspection and Overhaul Schedule 05-00-00	1 thru 3, 4 Blank	7	03/26/14
Section 25 Equipment and Furnishings 25-00-00	1 thru 6	7	03/26/14

THIS PAGE INTENTIONALLY LEFT BLANK

CONTENTS

<u><i>Identification</i></u>	<u><i>Title, Page</i></u>
<i>Section 0</i>	Introduction 00-00-00
	0.4 Scope, 1
	0.5 Purpose, 1
	0.6 Arrangement, 1
	0.7 Applicability, 1
	0.9 Abbreviations, 2
	0.12 Precautions, 2
	0.19 Distribution of Instructions for Continued Airworthiness, 2
<i>Section 4</i>	Airworthiness Limitations 04-00-00
	4.2 No airworthiness Limitations, 1
<i>Section 5</i>	Inspection and Overhaul Schedule 05-00-00
	5.1 Cargo Hook Kit Inspection, 1
	5.2 Cargo Hook Overhaul Schedule, 3
<i>Section 25</i>	Equipment and Furnishings 25-00-00
	25.1 Cargo Hook Connector, 1
	25.2 Description, 2
	25.5 Component Weights, 2
	25.12 Storage Instructions, 2
	25.15 Trouble Shooting, 3
	25.16 Cargo Hook Removal, 3
	25.17 Cargo Hook Re-installation, 4
	Connection of Manual release cable, 5
	25.18 General Procedures Instructions-Testing, 6
<i>Figures</i>	
	25-1 Un-commanded cargo hook release, Chapter 25 Page 1
	25-2 Cargo Hook Attachment Hardware, Chapter 25 Page 4
	25-3 Manual Release Cable Rigging, Chapter 25 Page 5
<i>Tables</i>	
	25-1 Cargo Hook Connector, Chapter 25 Page 1
	25-2 Component Weights, Chapter 25 Page 2
	25-3 Trouble Shooting, Chapter 25 Page 3

THIS PAGE INTENTIONALLY LEFT BLANK

Section 0

Introduction

0.4 Scope

The following information is necessary to carry out the service, maintenance, and inspection of the Cargo Hook Kit P/N 200-261-00.

CAUTION

Cargo Hook Kit P/N 200-261-00 consists of the cargo hook (P/N 528-023-01), a manual release cable adapter fitting, and an electrical connector only. It interfaces with the cargo hook suspension and the manual release cable and electrical wiring, as supplied by Airbus Helicopters, therefore this ICA must be used in conjunction with the applicable Airbus Helicopters documentation in the maintenance of the complete cargo hook suspension system.

0.5 Purpose

The purpose of this Instructions for Continued Airworthiness (ICA) manual is to provide the information necessary to service, maintain and inspect the P/N 200-261-00 Cargo Hook in an airworthy condition.

0.6 Arrangement

This manual contains instructions for the service, maintenance, inspection and operation of Cargo Hook P/N 528-023-01 on Airbus Helicopters AS350 helicopters. The manual is arranged in the general order that maintenance personnel would use to maintain and operate the cargo hook in service.

The arrangement is:

- Section 0 Introduction.
- Section 4 Airworthiness Limitations (None apply)
- Section 5 Inspection and Overhaul Schedule.
- Section 25 Equipment and Furnishings

0.7 Applicability

These Instructions for Continued Airworthiness are applicable to Cargo Hook P/N 528-023-01 installed as part of Kit P/N 200-261-00 on the Airbus Helicopters AS350B, AS350B1, AS350B2, AS350B3, AS350BA, AS350D, and EC130 B4.

0.9 Abbreviations

FAA Federal Aviation Administration
FAR Federal Aviation Regulation
ICA Instructions for Continued Airworthiness

0.12 Precautions

The following definitions apply to safety labels used in this manual.



Indicates a hazardous situation which, if not avoided, will result in death or serious injury.



Indicates a hazardous situation which, if not avoided, could result in death or serious injury.



Indicates a hazardous situation which, if not avoided, could result in minor or moderate injury.



Draws the reader's attention to important or unusual information not directly related to safety.



Used to address practices not related to personal injury.

0.19 Distribution of Instructions for Continued Airworthiness

Before performing maintenance ensure that the Instructions for Continued Airworthiness (ICA) in your possession is the most recent revision. Current revision levels of all manuals are posted on Onboard Systems Int'l web site at www.onboardsystems.com. Also a Documentation Update Service is available on the web site. Registering for this service provides an e-mail or fax notification when a manual has been revised. Hard copies of all manuals are available from the factory, contact the factory at 800-275-0883 to request a copy.

Section 4

Airworthiness Limitations

4.2 No airworthiness limitations

No airworthiness limitations associated with this type design change.

THIS PAGE INTENTIONALLY LEFT BLANK

Section 5

Inspection and Overhaul Schedule

5.1 Cargo Hook Kit Inspection

The scheduled inspection intervals noted below are maximums and are not to be exceeded. If the cargo hook is subjected to unusual circumstances, extreme environmental conditions, etc., it is the responsibility of the operator to perform the inspections more frequently to ensure proper operation.

Annually or 100 hours of external load operations, whichever comes first, inspect the cargo hook per the following. Refer also to the Component Maintenance Manual for the Cargo Hook (manual number 122-005-00) for additional inspection requirements.

NOTICE

*Hours of external load operations should be interpreted to be (1) anything is attached to the primary cargo hook (whether or not a useful load is being transported) and (2) the aircraft is flying. If these conditions are **NOT** met, time does **NOT** need to be tracked.*

1. Activate the electrical system and press the Cargo Release button to ensure the cargo hook electrical release system is operating correctly. The cargo hook mechanism must release the load beam. Reset the hook by hand after release. If the hook does not release or re-latch, do not use the unit until the problem is fixed.

CAUTION

Depressing the electrical release button continuously in excess of 20 seconds will cause the cargo hook release solenoid to overheat, possibly causing permanent damage.

2. Activate the manual release system by pulling the release lever on the collective in the cockpit. The cargo hook must release. Reset the cargo hook by hand after release. If the hook does not release or re-latch, do not use the unit until the problem is resolved.
3. Swing the cargo hook and the suspension system throughout their full ranges of motion to ensure the manual and electrical release cables have enough slack. The cables must not be the stops that prevent the cargo hook or suspension from swinging freely in all directions.
4. Visually check for presence and security of cargo hook fasteners and electrical connections.

5.1 Cargo Hook Kit Inspection continued

5. Check the rigging of the manual release cable at the cargo hook per the following.
 - Remove the manual release cover by cutting safety wire and removing two screws.
 - With the cable ball end engaged through the fork fitting as illustrated below and the load beam closed remove the play from the manual release lever by moving it in the clockwise direction until it encounters resistance and hold it in this position for the measurement following.



Manual release cable rigging must be done with the cargo hook in the closed and locked position.

- Measure the cable ball end free play with the manual release lever in the cockpit in the non-release position. The gap should measure a minimum of .125" (the maximum gap is limited by the manual release cover, i.e.- it must fit inside the cover).
- If necessary make adjustments at the lever in the cockpit or the manual release cable adapter can be threaded in to increase the gap or threaded out to decrease the gap. Maintain full thread engagement with the side plate boss and ensure the lever does not bottom out on the end of the manual release cable adapter.
- Re-install the manual release cover with the two screws and secure the screws with safety wire.

Figure 5.1.2 Manual Release Cable Rigging

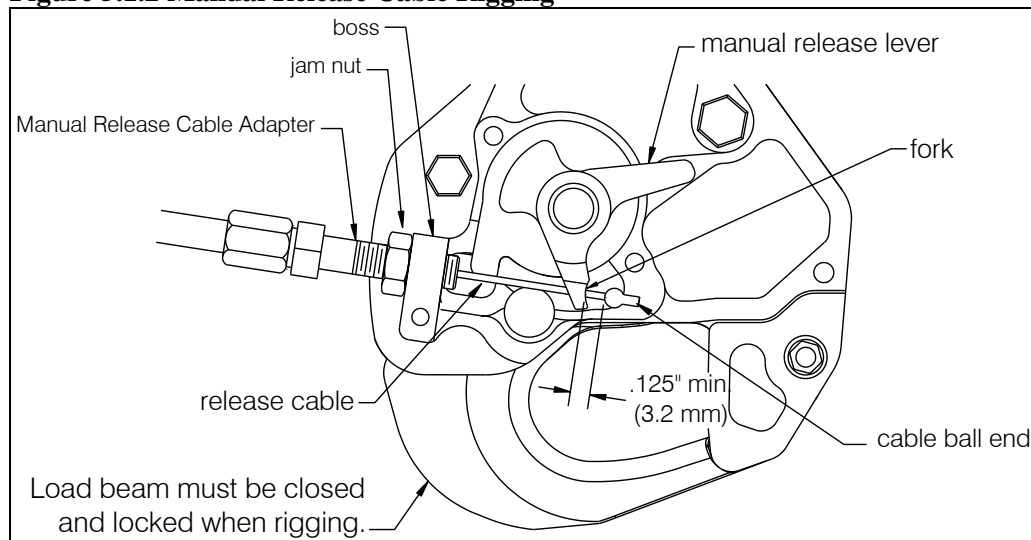

5.2 Cargo Hook Overhaul Schedule

Time Between Overhaul (TBO) for the cargo hook: 1000 hours of external load operations (*) or 5 years, whichever is less.



*Hours of external load operations should be interpreted to be (1) anything is attached to the primary cargo hook (whether or not a useful load is being transported) and (2) the aircraft is flying. If these conditions are **NOT** met, time does **NOT** need to be tracked.*

Overhaul the cargo hook per Component Maintenance Manual 122-005-00. Contact Onboard Systems for guidance to locate authorized overhaul facilities.

THIS PAGE INTENTIONALLY LEFT BLANK

Section 25

Equipment and Furnishings



Un-commanded cargo hook release will happen if the manual release cable is improperly restrained. The cable must not be the stops that prevent the Cargo Hook from swinging freely in all directions. If the Cargo Hook loads cause the hook to strain against the manual release cable the swaged end of the cable may separate allowing the inner cable to activate the cargo hook's internal mechanism. The result is an un-commanded release. Ensure that no combination of suspension and Cargo Hook position is restrained by the manual release cable.

Figure 25-1 Un-commanded cargo hook release

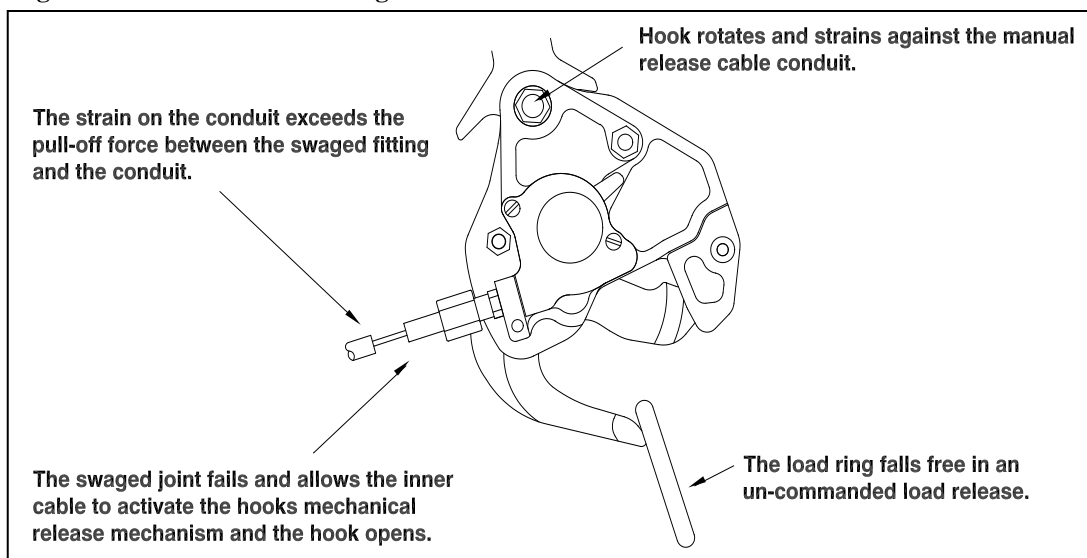

25.1 Cargo Hook Connector

Listed below is the pin out for the cargo hook connector.

Table 25-1 Cargo Hook Connector

<i>Pin</i>	<i>Function</i>
A	Ground
B	Positive

25.2 Description

The type design change consist of the installation of Cargo Hook Kit P/N 200-261-00 that uses the existing rotorcraft cargo hook suspension system, electrical and mechanical release systems. This cargo hook kit includes the cargo hook (P/N 528-023-01), an adapter to connect to the existing external manual release cable, and an electrical connector spliced onto the existing external electrical release cable.

The primary elements of the Cargo Hook are the load beam, the internal mechanism, and a DC solenoid. The load beam supports the load and is latched through the internal mechanism. The DC solenoid and an external manual release cable provide the means for unlatching the load beam.

25.5 Component Weights

The weight of the Cargo Hook is listed below.

Table 25-2 Component Weights

Item	Weight
Cargo Hook	3.1 lbs. (1.41 kgs.)

25.12 Storage Instructions

Refer to the Component Maintenance Manual (CMM) 122-005-00 for storage instructions for the cargo hook.

25.15 Trouble Shooting

Table 25-3 Trouble Shooting

MALFUNCTION	PROBABLE CAUSE	CORRECTIVE ACTION
Cargo hook does not operate electrically, manual cable release operates normally.	Open electrical circuit, faulty wiring, circuit breaker, switch or solenoid	Disconnect cable from electrical connector on Cargo Hook. Using multimeter, check for 3.0 to 4.0 ohms between pins A and B of electrical connector. If open indication is obtained, repair cargo hook per CMM 122-005-00.
Cargo hook does not operate electrically or manually.	Defective internal mechanism	Repair cargo hook per CMM 122-005-00.
Cargo hook operates electrically, but not manually.	Defective manual release cable Defective manual release system	Check manual release cable and its connection to Cargo Hook. Correct any defects. Repair cargo hook per CMM 122-005-00.
Load beam fails to relatch after being reset.	Defective latch mechanism	Repair cargo hook per CMM 122-005-00.
Cargo hook manual release cable pull-off force exceeds 8 Lbs. (at the hook).	Friction in internal mechanism.	Check operation of unit using manual release lever. Repair cargo hook per CMM 122-005-00.
Failure to open or relock properly	Failure to open or relock properly	Remove hook from service.
Circuit breaker opens when Cargo Hook is energized.	Short in the system, faulty wiring, circuit breaker or solenoid	Check for shorts to ground. Check solenoid resistance, repair or replace defective parts.

25.16 Cargo Hook Removal

1. Cut and remove all lockwire.
2. Remove manual release cover by removing 2 screws.
3. Remove the manual and electrical release cables from the Cargo Hook.
4. Remove the cotter pin P/N 510-178-00 from the Attach Bolt P/N 290-332-00.
5. Remove the castellated nut P/N 510-170-00 from the Attach Bolt.
6. Remove Attach Bolt and all washers.
7. Remove Cargo Hook from suspension system.

25.17 Cargo Hook Re-installation

1. Inspect the Cargo Hook for evidence of damage, corrosion and security of lock wire and fasteners. If damage is evident, do not use the items until they are repaired.
2. Verify that the part number of the cargo hook removed matches one of the numbers on the list in the Applicability section of this manual. If it does not, do not attempt to use the cargo hook, contact the factory for clarification.
3. Attach the Cargo Hook, P/N 528-023-01 to the suspension system by installing the bolt and washer P/N 290-332-00 and P/N 510-183-00 as illustrated in Figure 25-2.
4. Install washer P/N 510-183-00 and washer P/N 510-174-00 over bolt end.
5. Torque nut P/N 510-170-00 on bolt P/N 290-332-00 to finger tight until fully seated then rotate nut to previous castellation if needed to install and secure cotter pin P/N 510-178-00.
6. Connect the cargo hook electrical release cable connector to the Cargo Hook.

Figure 25-2 Cargo Hook Attachment Hardware

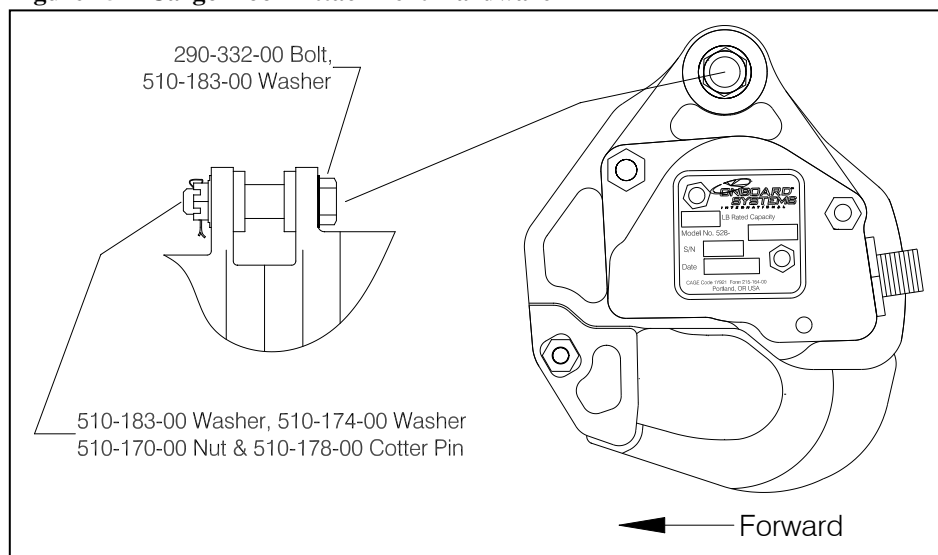

NOTICE

The Cargo Hook load beam must point forward when installed.

25.17 Cargo Hook Re-installation, continued

Connection of Manual Release Cable

1. Remove the manual release cover from the cargo hook.
2. Thread the manual release adapter, P/N 290-744-00 or 490-403-00, into the boss on the cargo hook side plate (see Figure 25-3). Tighten jam nut.
3. Connect the manual release cable to the adapter.
4. Place the cable ball end fitting into the hook manual release fork fitting as illustrated in Figure 25-3.
5. Move the manual release lever in the clockwise direction until it is against the cam stop.
6. Measure the cable ball end free play with the manual release handle in the cockpit in the non-release position.
7. Verify that the manual release cable system has a minimum of .125" of freeplay at the fork fitting as shown in Figure 25-3. If necessary adjust the system by unthreading the manual release cable nut, loosening the jam nut, and threading the manual release cable adapter in or out depending on required adjustment. Ensure the cable adapter fitting threads maintain full thread engagement with the side plate boss (i.e.- the end of the threads should not be recessed within the boss).
8. Re-install the manual release cover with the two screws and lockwire.



Manual release cable rigging must be done with the cargo hook in the closed and locked position.

Figure 25-3 Manual Release Cable Rigging

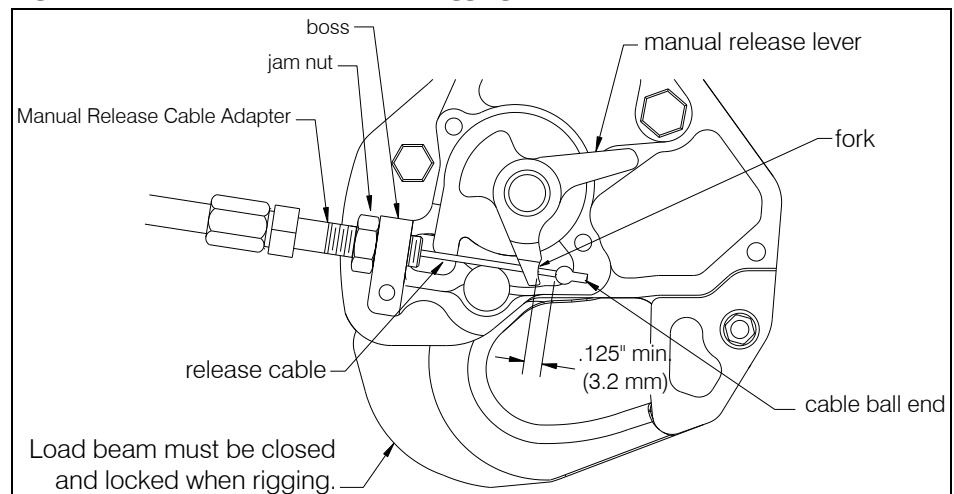

25.18 General Procedural Instructions -Testing

After re-installation of the cargo hook perform the following:

1. Activate the electrical system and press the Cargo Hook release button to ensure the cargo hook electrical release is operating correctly. The Cargo Hook must release. Reset the hook by hand after the release. If the hook does not release or relatch, do not use the unit until the difficulty is resolved.



Depressing the electrical release button continuously in excess of 20 seconds will cause the cargo hook release solenoid to overheat, possibly causing permanent damage.

2. Activate the release lever located between the seats to test the cargo hook manual release mechanism. The mechanism should operate smoothly and the Cargo Hook must release. Reset the hook by hand after release. If the hook does not release or relatch do not use the unit until the difficulty is resolved.
3. Swing the installed Cargo Hook to ensure that the manual release cable and the electrical release harness have enough slack to allow full swing of the cargo hook and suspension assembly without straining or damaging the cable or harness. The cable or harness must not be the stops that prevent the Cargo Hook from swinging freely in all directions.