

**PLEASE CHECK WEB SITE AT WWW.ONBOARDSYSTEMS.COM FOR
THE LATEST REVISION OF THIS MANUAL**

**Instructions for
Continued Airworthiness**

**Cargo Hook Kit
for the
Eurocopter AS350 Series
Helicopter**

**Part Number
200-281-03**

STC SR01166SE



13915 NW 3rd Court Vancouver, Washington 98685 USA
Phone: 360-546-3072 Fax: 360-546-3073 Toll Free: 800-275-0883
www.OnboardSystems.com

THIS PAGE INTENTIONALLY LEFT BLANK

Record of Revisions

<i>Revision</i>	<i>Date</i>	<i>Page(s)</i>	<i>Reason for Revision</i>
0	03/05/10	All	Initial Release
1	07/25/12	Section 5	Expanded annual/100 hour inspection of manual release cable, added details for 1000 hour/5 year inspection of Link Bumper Assembly.

Register Your Products for Automatic Notifications

Onboard Systems offers a free notification service via fax or email for product alerts and documentation updates. By registering your Onboard Systems products at our website, we will be able to contact you if a service bulletin is issued, or if the documentation is updated.

You can choose to receive notices on an immediate, weekly, or monthly schedule via fax, email or both methods. There is no charge for this service. Please visit our website at www.onboardsystems.com/notify.php to get started.

THIS PAGE INTENTIONALLY LEFT BLANK

List of Effective Pages

Title	Pages	Revision
Cover	i, ii Blank	1
Record of Revisions	iii ,iv Blank	1
List of Effective Pages	v, vi Blank	1
Table of Contents	vii, viii	1
Section 0 Introduction 00-00-00	1, 2	0
Section 4 Airworthiness Limitations 04-00-00	1, 2 Blank	0
Section 5 Inspection and Overhaul Schedule 05-00-00	1 thru 6	1
Section 25 Operation Instructions 25-00-00	1 thru 11	0

THIS PAGE INTENTIONALLY LEFT BLANK

CONTENTS

<u>Identification</u>	<u>Title, Page</u>
Section 0	Introduction 00-00-00
	0.4 Scope, 1
	0.5 Purpose, 1
	0.6 Arrangement, 1
	0.7 Applicability, 1
	0.9 Abbreviations, 1
	0.12 Precautions, 2
	0.19 Distribution of Instructions for Continued Airworthiness, 2
Section 4	Airworthiness Limitations 04-00-00
	4.2 No airworthiness Limitations, 1
Section 5	Inspection and Overhaul Schedule 05-00-00
	5.1 Cargo Hook Kit Inspection Schedule, 1
	5.2 Cargo Hook Kit Overhaul Schedule, 6
Section 25	Equipment and Furnishings 25-00-00
	25.1 Cargo Hook Connector, 1
	25.2 Description, 2
	25.5 Component Weights, 3
	25.12 Storage Instructions, 3
	25.15 Trouble Shooting, 4
	25.16 Component Removal, 6
	25.17 Component Re-installation, 8
	25.18 General Procedures Instructions-Testing, 11
Figures	
	5.1.1 Hook Lock Indicator, Section 5 Page 2
	5.1.2 Manual Release Cable Inspection, Section 5 Page 3
	5.1.3 Manual Release Cable Conditions, Section 5 Page 3
	5.1.4 Link Bumper Assembly Components, Section 5 Page 4
	25.1 Un-commanded cargo hook release, Section 25 Page 1
	25.2.1 Primary Kit Components, Section 25 Page 2
	25.2.2 Cargo Hook Overview, Section 25 Page 3
	25.15.1 Cargo Hook Electrical Connector, Section 25 Page 5
	25.16.1 Manual Release Cable Connection, Section 25 Page 6
	25.16.2 Manual Release Cover Removal, Section 25, Page 6
	25.16.3 Cargo Hook Connector, Section 25, Page 7
	25.17.1 Cargo Hook Attachment Hardware, Section 25, Page 8
	25.17.2 Manual Release Cable Adjustment, Section 25, Page 9
	25.17.3 Manual Release Cable Connection, Section 25, Page 9
	25.17.4 Manual Release Cable Rigging, Section 25, Page 10

CONTENTS *continued*

Tables

- 5.1.1 Link Bumper Assembly Inspection Criteria, Section 5 Page 5
- 25.1.1 Cargo Hook Connector, Section 25 Page 1
- 25.5.1 Component Weights, Section 25 Page 2
- 25.15.1 Trouble Shooting, Section 25 Page 4

Section 0

Introduction

0.4 Scope

The following information is necessary to carry out the service, maintenance, and inspection of the Cargo Hook Kit P/N 200-281-03. Cargo Hook Kit P/N 200-281-03 is a replacement cargo hook kit (see Section 25.2 for detailed kit description) which uses the existing Eurocopter swing suspension and the fixed provisions including internal electrical wiring and manual release cable. Refer to appropriate Eurocopter maintenance documentation for those components which interface with the P/N 200-281-03 cargo hook kit.

0.5 Purpose

The purpose of this Instructions for Continued Airworthiness (ICA) manual is to provide the information necessary to inspect, service, and maintain in an airworthy condition the P/N 200-281-03 Cargo Hook Kit.

0.6 Arrangement

This manual contains instructions for the service, maintenance, inspection and operation of the Cargo Hook Kit P/N 200-281-03 on Eurocopter Model AS350 helicopters. The manual is arranged in the general order that maintenance personnel would use to install, maintain and operate the Cargo Hook in service.

The arrangement is:

- Section 0 Introduction.
- Section 4 Airworthiness limitations (None apply to this System.)
- Section 5 Inspection and overhaul schedule
- Section 25 Equipment and Furnishings

0.7 Applicability

These Instructions for Continued Airworthiness are applicable to Cargo Hook Kit P/N 200-281-03 (with Cargo Hook P/N 528-029-00) for the Eurocopter AS350B3 helicopter. Refer to the appropriate Eurocopter ICA for instructions regarding parts of the aircraft that interface with the P/N 200-281-03 system.

0.9 Abbreviations

FAA Federal Aviation Administration
ICA Instructions for Continued Airworthiness
CFR Code of Federal Regulations

0.12 Precautions

The following definitions apply to precaution flags used in this manual.



Indicates a hazardous situation which, if not avoided, will result in death or serious injury.



Indicates a hazardous situation which, if not avoided, could result in death or serious injury.



Indicates a hazardous situation which, if not avoided, could result in minor or moderate injury.



Draws the reader's attention to important or unusual information not directly related to safety.



Used to address practices not related to personal injury.

0.19 Distribution of Instructions for Continued Airworthiness

Before performing maintenance ensure that the Instructions for Continued Airworthiness (ICA) in your possession is the most recent revision. Current revision levels of all manuals are posted on Onboard Systems Int'l web site at www.onboardsystems.com. Also a Documentation Update Service is available on the web site. Registering for this service provides an e-mail or fax notification when a manual has been revised. Hard copies of all manuals are available from the factory, contact the factory at 800-275-0883 to request a copy.

Section 4

Airworthiness Limitations

4.2 No Airworthiness Limitations

The Airworthiness Limitations section is FAA approved and specifies maintenance required under 14 CFR §§ 43.16 and 91.403, unless an alternative program has been FAA approved.

No airworthiness limitations are associated with this type design change.

THIS PAGE INTENTIONALLY LEFT BLANK

Section 5

Inspection and Overhaul Schedule

5.1 Cargo Hook Kit Inspection Schedule

The scheduled inspection interval(s) presented below are maximums and are not to be exceeded. If the cargo hook is subjected to unusual circumstances, extreme environmental conditions, etc., it is the responsibility of the operator to perform the inspections more frequently to ensure proper operation. Refer to cargo hook component maintenance manual 122-017-00 for damage and wear tolerances.

Annually or 100 hours of external load operations, whichever comes first, inspect the cargo hook kit per the following.

NOTICE

*Hours of external load operations should be interpreted to be (1) anything is attached to the primary cargo hook (whether or not a useful load is being transported) and (2) the aircraft is flying. If these conditions are **NOT** met, time does **NOT** need to be tracked.*

1. Activate the electrical system and press the Cargo Release button to ensure the cargo hook electrical release system is operating correctly. The cargo hook must release. Reset the cargo hook by hand after release. If the hook does not release or re-latch, do not use the unit until the problem is resolved.

CAUTION

Actuating the electrical release switch continuously in excess of 20 seconds will cause the cargo hook release solenoid to overheat, possibly causing permanent damage.

2. Activate the manual release system by pulling the release lever in the cockpit. The cargo hook must release. Reset the cargo hook by hand after release. Verify that the hook lock indicator on the side of the hook returns to the fully locked position (see Figure 5.1.1). If the hook does not release or re-latch, do not use the unit until the problem is resolved.

5.1 Cargo Hook Kit Inspection Schedule *continued*



In the fully locked position the hook lock indicator must align with the lines on the manual release cover (see Figure 5.1.1).

Figure 5.1.1 Hook Lock Indicator

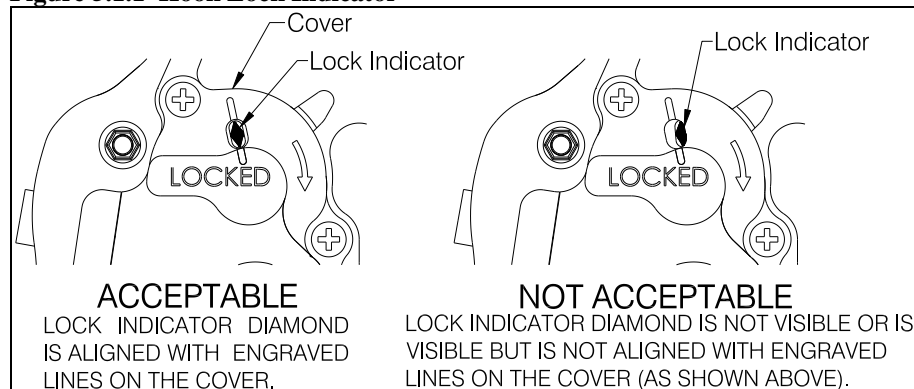

3. Move the cargo hook throughout its full range of motion to ensure the manual release cable and electrical harnesses have enough slack. The manual release cable or electrical harnesses must not be the stops that prevent the cargo hook from swinging freely in all directions.
4. Visually inspect for presence and security of fasteners and electrical connections.
5. Visually inspect the cargo hook side plates and covers for damage including cracks, gouges, and nicks (refer to the cargo hook component maintenance manual (CMM) for damage limits).
6. Visually inspect the cargo hook load beam for damage including cracks, wear, gouges, and nicks (refer to the cargo hook CMM for damage limits).

5.1 Cargo Hook Kit Inspection Schedule continued

7. Visually inspect the manual release cable for damage, paying close attention to the flexible conduit at the area of transition to the cargo hook end fitting (refer to Figure 5.1.2). Inspect for splitting of the outer black conduit in this area and separation of the conduit from the steel end fitting.

Figure 5.1.2 Manual Release Cable Inspection

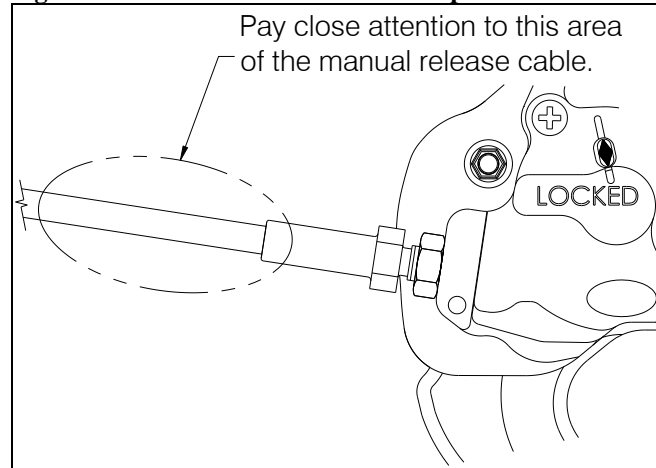

8. Remove the manual release cover from the cargo hook and inspect the visible section of the inner cable for kinks or frays.



Manual release cables are wearable items and must be replaced as condition requires. Broken or kinked conduit, inner cable kinks (ref Figure 5.1.3), frays, or sticky operation are each cause for immediate replacement.

Figure 5.1.3 Manual Release Cable Conditions

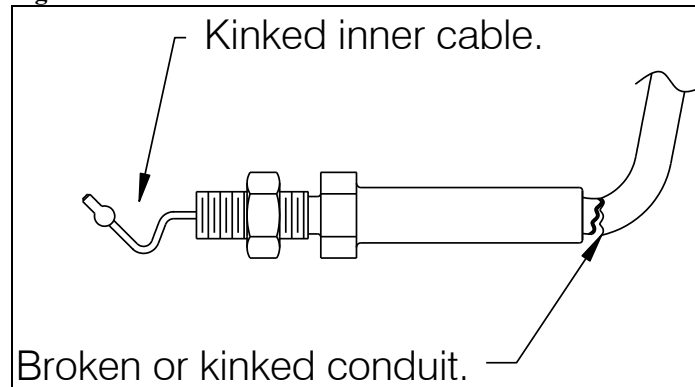

5.1 Cargo Hook Kit Inspection Schedule continued

At cargo hook overhaul (see section 5.2 for schedule), remove the kit components from the helicopter, disassemble, and inspect the component parts except cargo hook per this section. Refer to CMM 122-005-00 for cargo hook overhaul instructions.

Disassemble the Link Bumper Assembly referring to the figure below. The bushings do not need to be pressed out of the Link unless they need to be replaced per the criteria in Table 5.1.1.

Figure 5.1.4 Link Bumper Assembly Components

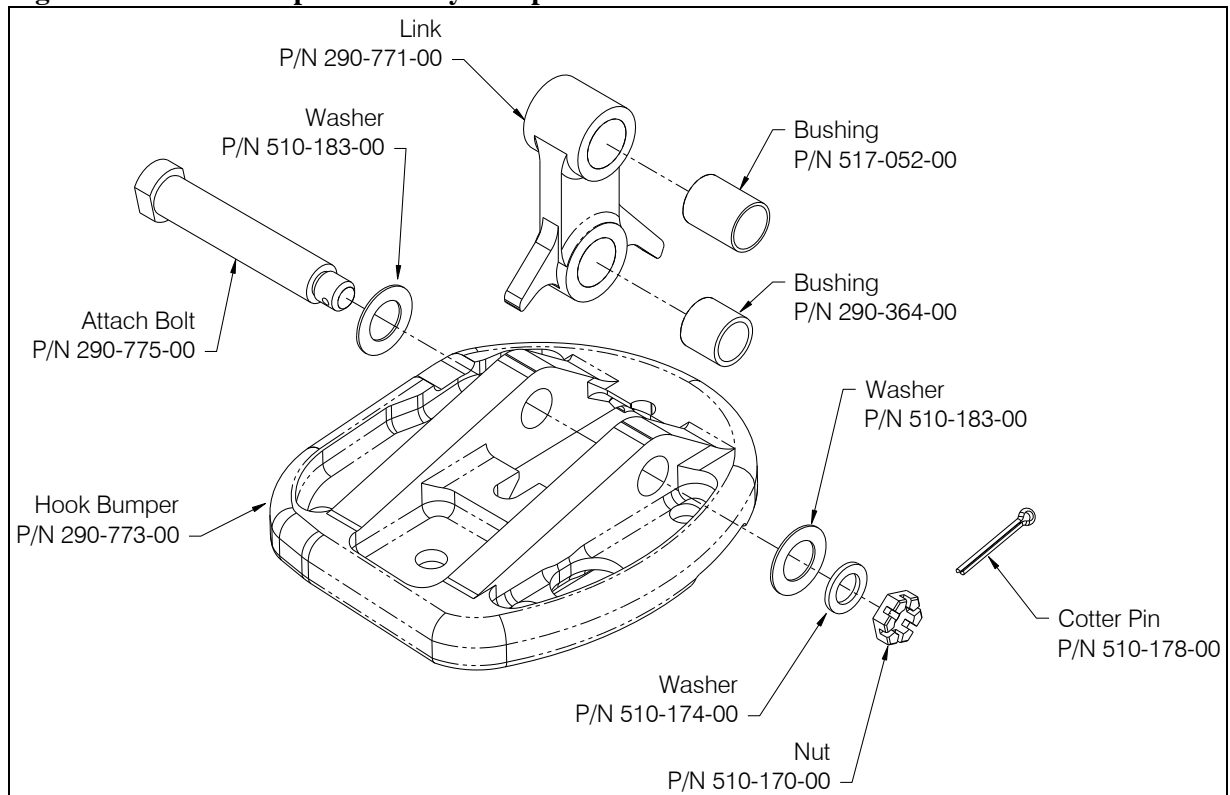

5.1 Cargo Hook Kit Inspection Schedule continued

Carefully inspect, and if necessary repair, the detail parts in accordance with the instructions in Table 5.1.1.

Table 5.1.1 Link Bumper Assembly Inspection Criteria

Component	Damage Permitted without Repair	Repair	Maximum Damage which Causes Replacement
Link P/N 290-771-00	Dents, gouges, and scratches less than .010" deep.	Blend at 20:1 ratio, length to depth, to provide smooth transitions.	Dents, gouges and scratches greater than .030". Visible cracks.
Bushing P/N 517-052-00	These bushings have a Teflon type film overlaid on a layer of sintered copper. Teflon film still covers more than 50% of the bushing wear area.	None.	If copper is visible over more than 50% of the bushing wear area, remove and replace the bushing.
Bumper, P/N 290-773-00	Gouges less than .060" deep.	None.	Gouges greater than .060" deep.
Attach Bolt, P/N 290-775-00	Wear on outside diameter, diameter greater than .495".	None.	Wear on outside diameter, diameter less than .495". Visible cracks.
Bushing P/N 290-364-00	Wear on inside diameter, diameter less than .510".	None.	Wear on inside diameter, diameter greater than .510".

5.2 Cargo Hook Kit Overhaul Schedule

Overhaul the cargo hook in accordance with the guidelines below.

Time Between Overhaul (TBO): 1000 hours of external load operations or 5 years, whichever comes first.



*Hours of external load operations should be interpreted to be (1) anything is attached to the primary cargo hook (whether or not a useful load is being transported) and (2) the aircraft is flying. If these conditions are **NOT** met, time does **NOT** need to be tracked.*

Overhaul the cargo hook per component maintenance manual 122-017-00. Contact Onboard Systems for guidance in locating authorized overhaul facilities.

Section 25

Equipment and Furnishings



Un-commanded cargo hook release will happen if the manual release cable is improperly restrained. The cable must not be the stops that prevent the Cargo Hook from swinging freely in all directions. If the Cargo Hook loads cause the hook to strain against the manual release cable the swaged end of the cable may separate allowing the inner cable to activate the cargo hook manual release mechanism. The result is an un-commanded release. Ensure that no combination of cyclic stick or Cargo Hook position is restrained by the manual release cable.

Figure 25.1 Un-commanded cargo hook release

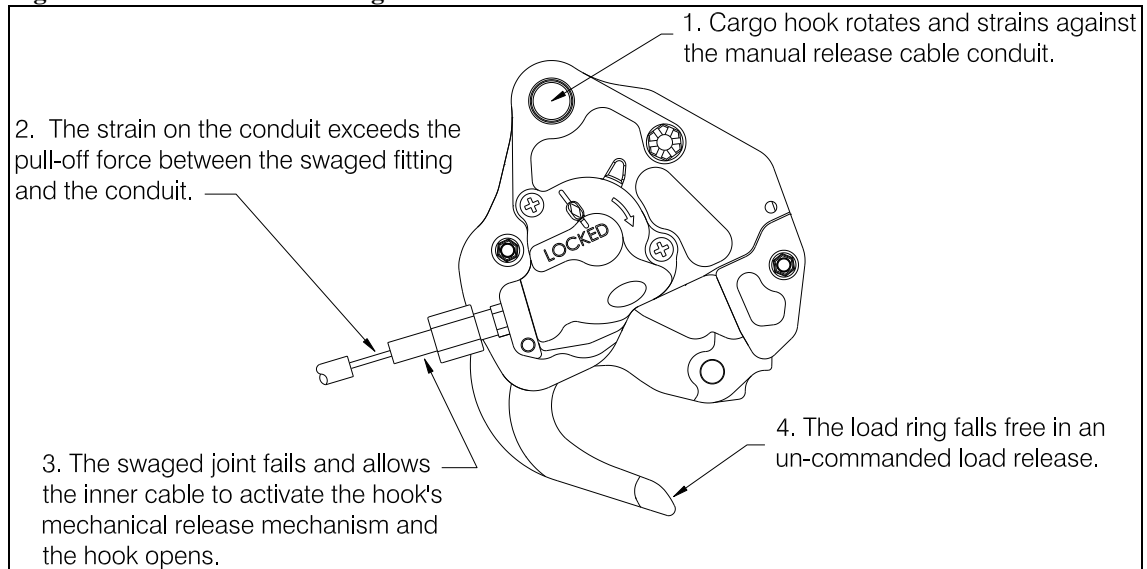

25.1 Cargo Hook Connector

Listed below is the pin out for the cargo hook connector.

Table 25.1.1 Cargo Hook Connector

<i>Pin</i>	<i>Function</i>
A	Ground
B	Positive

25.2 Description

The primary components of the 200-281-03 Cargo Hook Kit are (see Figure 25.2.1 and Table 25.2.1 for identification):

1. The Cargo Hook, which attaches to the AS350 swing suspension through a supplied adapter link/bumper assembly.
2. A manual release cable, which interfaces with the helicopter's existing fixed manual release cable.
3. A bumper, which provides protection for the manual and electrical release cables.
4. An electrical connector, which is supplied to splice into and interface with the helicopter's electrical release system.

Figure 25.2.1 Primary Kit Components

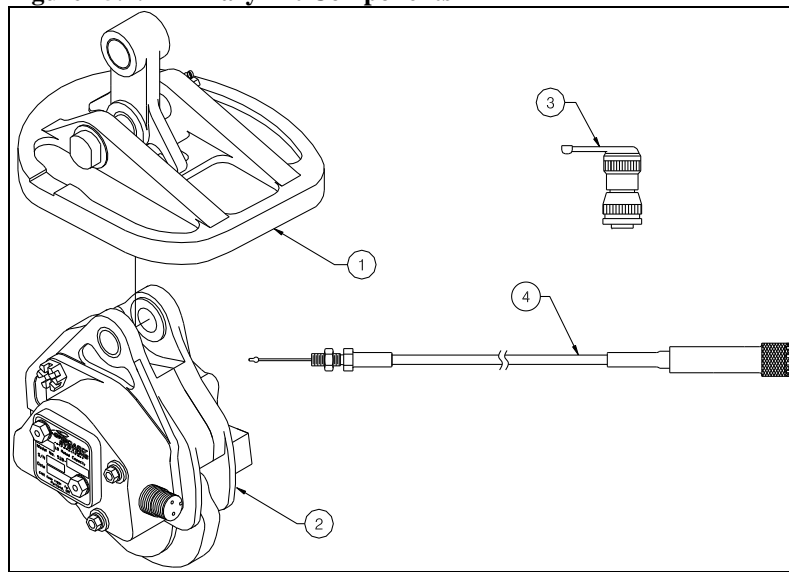

Table 25.2.1 Primary Kit Components

Item	Part No.	Description
1	232-149-00	Link Bumper Assembly
2	528-029-00	Talon LC 3.6K Cargo Hook Assembly
3	230-077-00	Connector Assembly
4	268-024-02	Manual Release Cable Assembly

A load is attached to the cargo hook by passing a load ring into the throat of the load beam and pushing the ring against the upper portion of the load beam throat (see Figure 25.2.2), which will initiate the hook to close. In the closed position, a latch engages the load beam and latches it in this position. A load release can be initiated by three different methods. Normal release is achieved by pilot actuation of a push-button switch in the cockpit. When the push-button switch is pressed, it energizes the solenoid in the cargo hook, and the solenoid opens the latch in the internal mechanism.

25.2 Description continued

In the event of an electrical failure, load release can be achieved by operating the manual release cable. The release cable actuates the internal mechanism of the cargo hook to unlatch the load beam. A rigging window provides a means to verify the manual release cable setting with respect to the internal mechanism. Ground personnel can also release the load by actuating a manual release lever located on the side of the cargo hook (see Figure 25.2.2).

Figure 25.2.2 Cargo Hook Overview

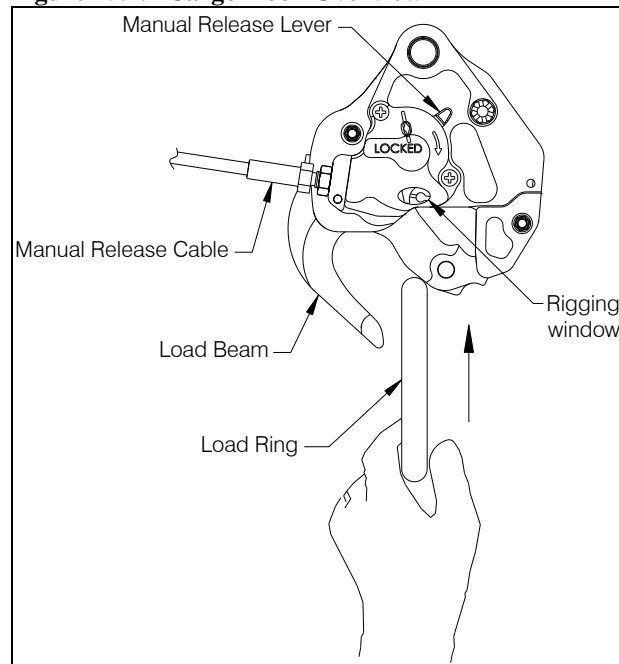

25.5 Component Weights

The weight of the system is listed in Table 25.5.1. Refer to Eurocopter manual for location of cargo hook.

Table 25.5.1 Component Weights

Item	Weight
P/N 200-281-03	4.7 lbs (2.2 kgs)

25.12 Storage Instructions

Clean the exterior Cargo Hook components thoroughly of excess dirt and grease with a rag before packaging. Pack the unit in a heat-sealable package. If the unit is to be stored for long periods in a tropical climate it should be packed in a reliable manner to suit local conditions. Refer to MIL-PRF-23199 and MIL-STD-2073-1 for additional guidance.

Package the unit in a suitable fiberboard box and cushion the unit to prevent shifting. Seal the fiberboard box with tape and mark the box with the contents and date of packaging.

25.15 Troubleshooting

Table 25.15.1 is provided with the intention of isolating the cause of malfunctions within the system. Sections 25.16 and 25.17 include instructions for removing and replacing defective components. Refer to the appropriate Eurocopter maintenance for guidance on procedures relating to Eurocopter parts that interface with the cargo hook and adapter cable.

Table 25.15.1 Troubleshooting

MALFUNCTION	PROBABLE CAUSE	CORRECTIVE ACTION
Cargo hook does not operate electrically, manual cable release operates normally.	Open electrical circuit, faulty wiring, fuse, switch or solenoid.	Disconnect cable from electrical connector on cargo hook. Using multi-meter, check for 3.0 to 4.0 ohms between pins A and B of electrical connector (see note 1). If open indication is obtained, remove and replace cargo hook (see sections 25.16 and 25.17).
Cargo hook does not operate electrically or manually.	Defective internal mechanism	Remove and replace cargo hook (see sections 25.16 and 25.17) or repair per cargo hook service manual 122-017-00.
Cargo hook operates electrically, but not manually.	Defective manual release cable. Defective manual release system.	Check manual release cable and cable connection to cargo hook (remove and replace manual release cable per sections 25.16 and 25.17). Remove and replace cargo hook (see sections 25.16 and 25.17) or repair per cargo hook service manual 122-017-00.
Load beam fails to re-latch after being reset.	Defective latch mechanism.	Remove and replace cargo hook (see sections 25.16 and 25.17) or repair per cargo hook service manual 122-017-00.
Cargo hook manual release cable pull-off force exceeds 8 Lbs. (at the hook).	Friction in internal mechanism.	Check operation of unit using manual release lever. Remove and replace cargo hook (see sections 25.16 and 25.17) or repair per cargo hook service manual 122-017-00.
Visibly loose fasteners or missing locking pins	Visibly loose fasteners or missing locking pins.	Re-torque and re-install locking pins per installation instructions.
Failure to open or re-lock properly	Failure to open or re-lock properly.	Remove and replace cargo hook (see sections 25.16 and 25.17) or repair per cargo hook service manual 122-017-00.
Fuse opens when cargo hook is energized.	Short in the system, faulty wiring, fuse or solenoid.	Check for shorts to ground. Check solenoid resistance (see note 1).

Notes:

1. Checking resistance at pins A and B.

Check for 3.0 to 4.0 ohms between pins A and B of electrical connector located on the cargo hook (see below).

Figure 25.15.1 Cargo Hook Electrical Connector

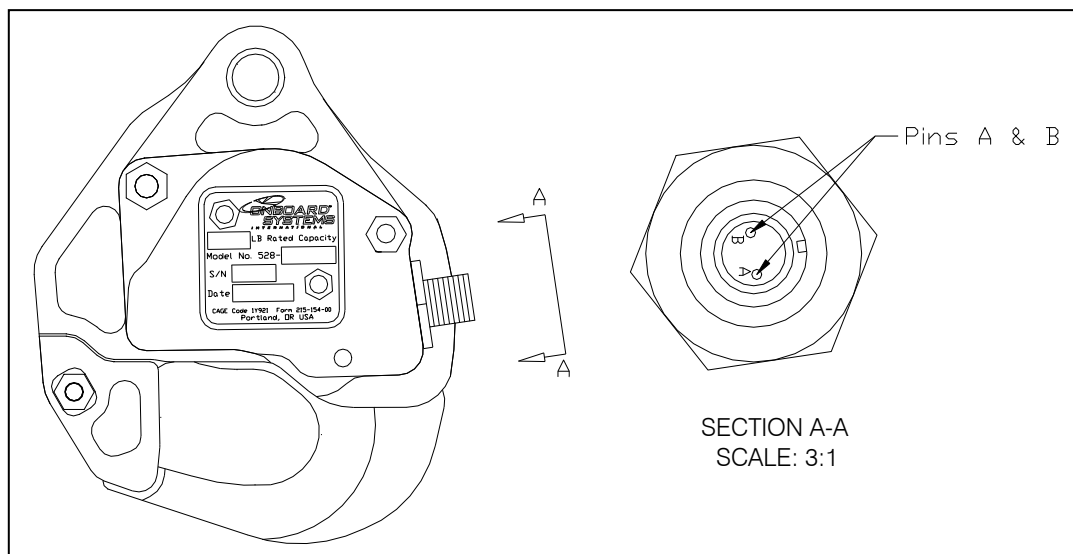

25.16 Component Removal

Cargo Hook Removal

1. Remove manual release cover by removing 2 screws.
2. Loosen jam nut and unthread the manual release cable from the Cargo Hook.
3. Disconnect the electrical release connector at the cargo hook.
4. Remove the cotter pin P/N 510-178-00 from the Attach Bolt P/N 290-775-00 (reference Figure 25.17.1).
5. Remove the castellated nut P/N 510-170-00 from the Attach Bolt.
6. Remove Attach Bolt and all washers.
7. Remove cargo hook.

Manual Release Cable Removal

1. Disconnect the cable at the joint with the fixed manual release cable on the belly of the helicopter by disengaging the retaining pin and unthreading the adapter fitting to expose and disengage the cable end fittings.

Figure 25.16.1 Manual Release Cable Connection

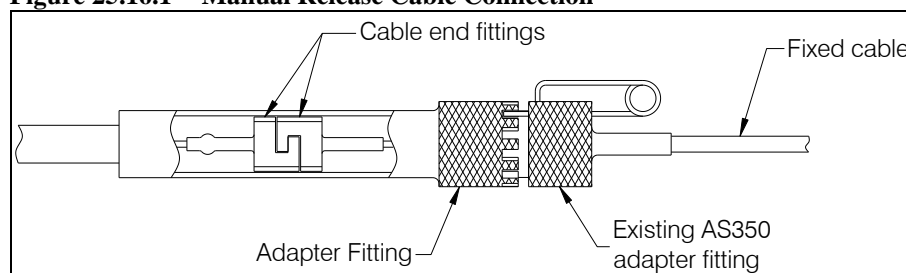

2. At the other end of the cable (at the cargo hook) remove the two screws that secure the manual release cover to the hook (see below), unhook the cable ball end from the fork fitting, and unthread the manual release cable from the cargo hook.

Figure 25.16.2 Manual Release Cover Removal

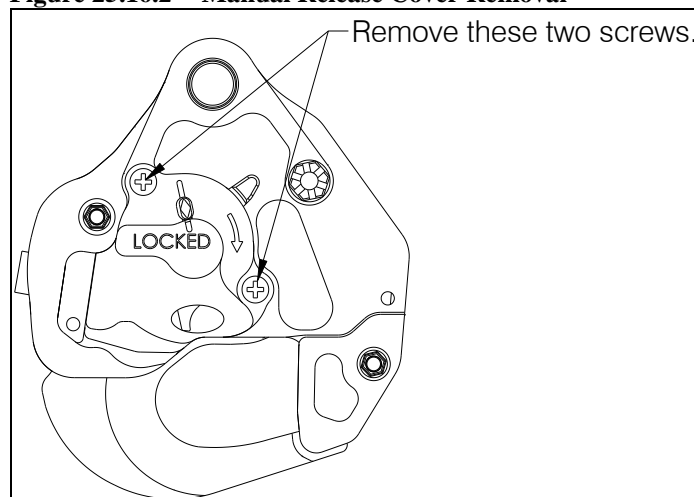

25.16 Component Removal *continued*

Electrical Connector Removal

The kit supplied connector (P/N 230-077-00) replaces the connector on the end of the Eurocopter external harness.

1. Loosen the set screw on the backshell.
2. Unthread the backshell from the connector base to expose the solder contacts and de-solder the wires.
3. Cut safety wire and unthread the connector base from the cargo hook connector.

Figure 25.16.3 Cargo Hook Connector

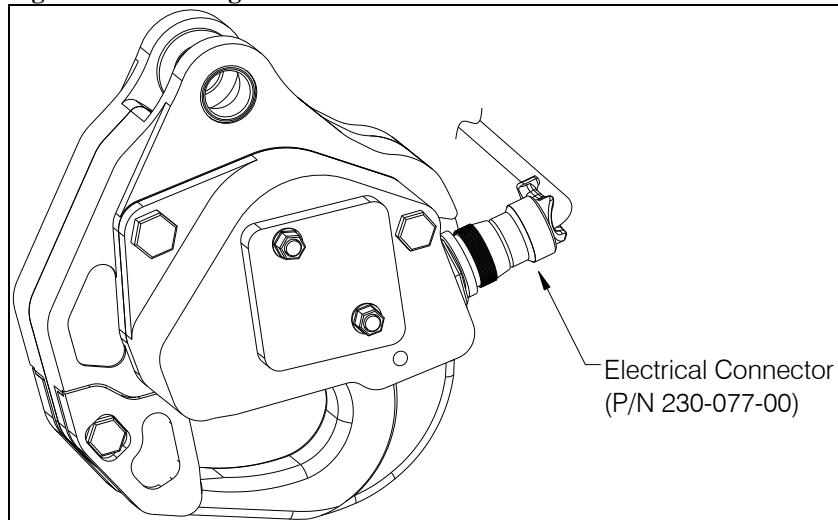

25.17 Component Re-installation

Cargo Hook Re-installation

1. Attach the Cargo Hook (P/N 528-029-00) and Cargo Hook Bumper (P/N 290-773-00) to the Adapter Link on the swing suspension system with the Attach Bolt (P/N 290-775-00) and washer (P/N 510-183-00) as illustrated in Figure 25-5.
2. Install washer (P/N 510-183-00) and washer (P/N 510-174-00) over bolt end.
3. Tighten nut P/N 510-170-00 on the Attach Bolt to finger tight, then rotate nut to next castellation to install and secure cotter pin (P/N 510-178-00).

Figure 25.17.1 Cargo Hook Attachment Hardware

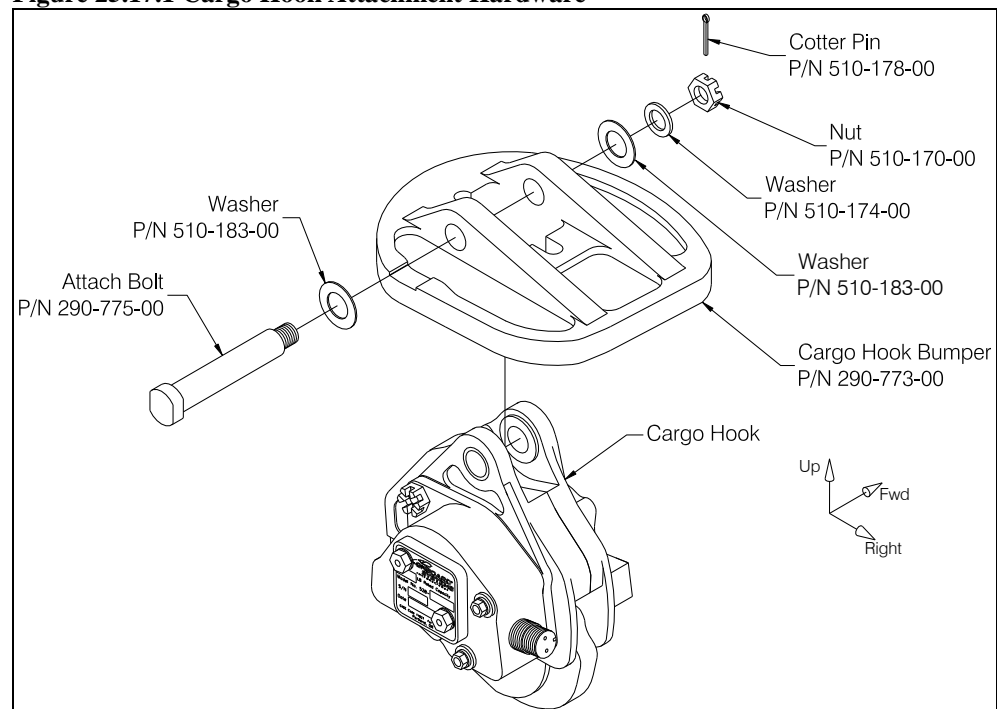

NOTICE

The Cargo Hook Load Beam must point to the left side of the helicopter when looking from the rear.

25.17 Component Re-installation, continued

Connect the manual release cable (P/N 268-024-02) to the cargo hook per the following instructions:

1. Remove the manual release cover from the cargo hook (see Figure 25.16.2).
2. Thread the fitting at the end of the manual release cable into the manual release boss on the hook side plate until the threads protrude approximately .125 inches beyond the boss and secure with jam nut (as shown in Figure 25.17.2). Leave the cover off of the cargo hook until the other end of the release cable is connected, in order to verify proper setting.

Figure 25.17.2 Manual Release Cable Adjustment

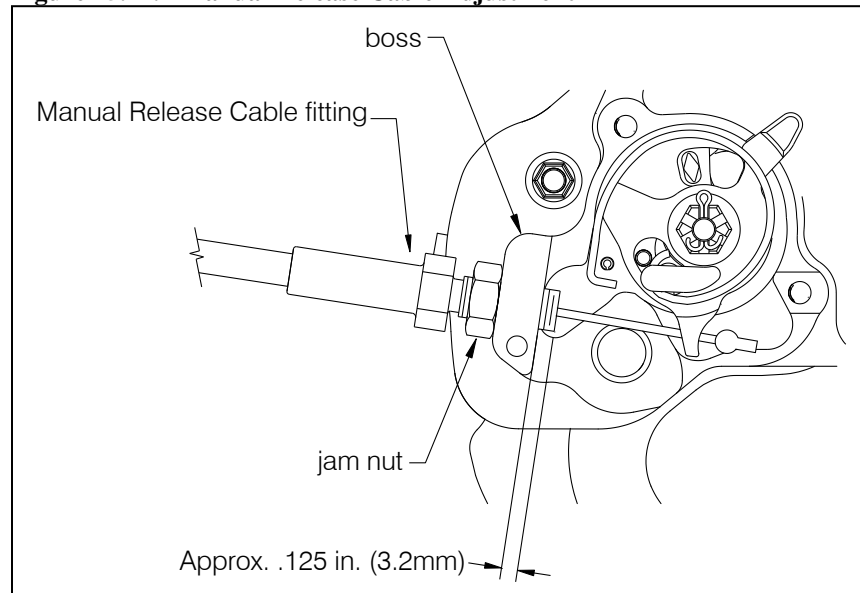

3. Connect the other end of the release cable to the fixed section of the existing AS350 manual release cable by mating the cable end fittings together as shown below. Slide the Adapter Fitting forward and thread it onto the existing AS350 fitting, and engage a castellation on the Adapter Fitting with the retaining pin to lock it in place.

Figure 25.17.3 Manual Release Cable Connection

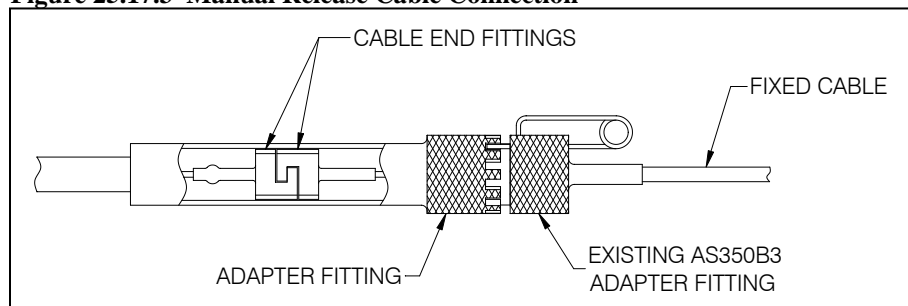

25.17 Component Re-installation, continued

Cargo Hook Re-installation

4. At the cargo hook, place the cable ball end fitting into the manual release lever fork as illustrated in Figure 25.17.4.



Manual release cable rigging must be done with the cargo hook in the closed and locked position.

5. With the cargo hook in the closed and locked position, rotate the release lever in the clockwise direction to remove free play (the free play is taken up when the hook lock indicator begins to move) and measure the cable ball end free play with the manual release lever in the cockpit in the non-release position. There must be a minimum of .125 inches (3.2 mm) between the cable ball end and fork fitting as shown in Figure 25.17.4. The maximum amount of free play is limited by the manual release cover, i.e. – the ball end must fit inside the manual release cover when it is installed.
6. If necessary adjust the manual release cable system to obtain a minimum of .125 inches (3.2 mm). Some adjustment can be made at the cargo hook by loosening the jam nut and turning the manual release cable or cargo hook in the required direction and re-tightening the jam nut. Ensure the manual release cable fitting threads maintain full thread engagement with the cargo hook side plate boss (i.e.- the end of the threads should not be recessed within the boss).
7. Re-install the manual release cover with the two screws.

Figure 25.17.4 Manual Release Cable Rigging

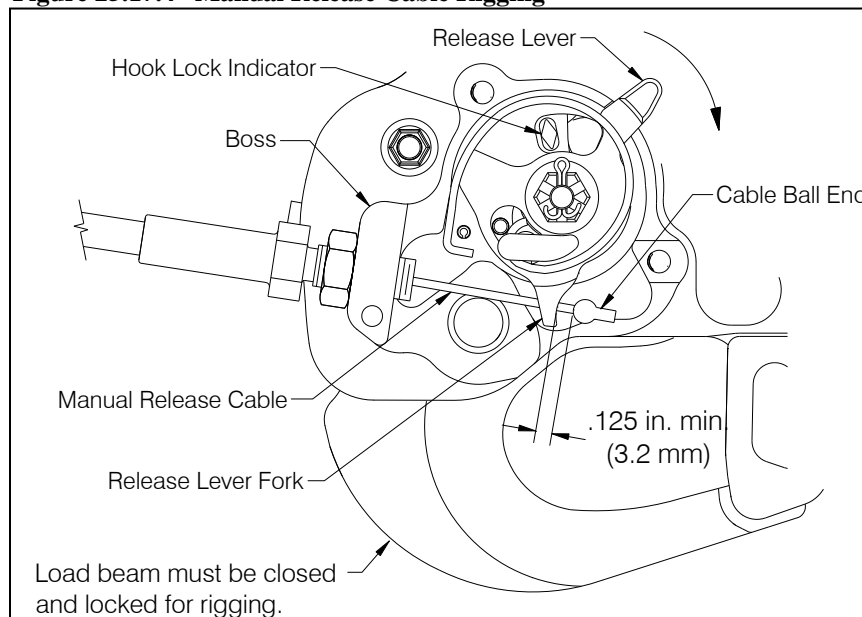

25.18 General Procedural Instructions-Testing

After re-installation, perform the following:

1. Activate the electrical system and press the Cargo Release button to ensure the cargo hook electrical release system is operating correctly. The cargo hook must release. Reset the cargo hook by hand after release. If the hook does not release or re-latch, do not use the unit until the problem is resolved.



Actuating the electrical release switch continuously in excess of 20 seconds will cause the cargo hook release solenoid to overheat, possibly causing permanent damage.

2. Activate the manual release system by pulling the release lever in the cockpit. The cargo hook must release. Reset the cargo hook by hand after release. Verify that the hook lock indicator on the side of the hook returns to the fully locked position. If the hook does not release or re-latch, do not use the unit until the problem is resolved.



In the fully locked position the hook lock indicator must align with the lines on the manual release cover (see Figure 5.1.1).

3. Swing the installed cargo hook and the suspension to ensure that the manual release cable and the electrical release harness have enough slack to allow full swing of the cargo hook and suspension assembly without straining or damaging the cable or harness. The cable or harness must not be the stops that prevent the Cargo Hook from swinging freely in all directions.