

**PLEASE CHECK WEB SITE AT WWW.ONBOARDSYSTEMS.COM FOR
THE LATEST REVISION OF THIS MANUAL**

**Instructions for
Continued Airworthiness**

**Talon LC Hydraulic
Cargo Hook Kits**

For the
MD Helicopters' 369 Series and 500N

System Part Numbers
200-378-00, 200-378-10, 200-379-00,
200-379-01, 200-379-10, 200-379-11

STC SR01778SE



13915 NW 3rd Court Vancouver, Washington 98685 USA
Phone: 360-546-3072 Fax: 360-546-3073 Toll Free: 800-275-0883
www.OnboardSystems.com

THIS PAGE INTENTIONALLY LEFT BLANK

Record of Revisions

<i>Revision</i>	<i>Date</i>	<i>Page(s)</i>	<i>Reason for Revision</i>
0	07/13/11	All	First Issue
1	12/19/11	Section 12 page 3, 4	Replaced Cup Seal P/N 556-038-00 with Quad Seal 556-097-00 inside Slave Cylinder Assembly.
2	05/01/12	Section 5 pages 4 – 6 Section 25 page 2, 3, 5, 10, 15	Added attach point assembly part number 232-449-01 and pivot link part number 291-484-01. Updated troubleshooting table (Table 25.15.1). Updated external load operations definition.
3	11/20/13	Section 0 page 2, Section 25 page 17	Updated section 0.19 to reflect option automatic documentation updates, updated tightening instructions for nut on pin load cell and attach bolt.
4	08/21/15	Section 5 pages 3-5, Section 12 page 10, Section 25 pages 3, 16, 17	Added pin load cell P/N 210-301-03. Clarified lubrication points and tightening instructions upon re-assembly.
5	02/05/16	Section 0 page 1, Section 5 pages 1 thru 5, Section 11, page 1, Section 25 pages 2 thru 6, 10, 14, 16, 22	Added kit P/Ns 200-378-10, 200-379-01, 200-379-10, and 200-379-11. P/N 200-378-10, 200-379-10, and 200-379-11 include cargo hook P/N 528-028-02 with Surefire Release. Added instructions associated with these new kits.
6	09/13/17	Section 5 pages 4, 5 Section 12 pages 2, 5, & 7	Removed attach bolt P/N 290-332-00 from NDT list and revised outside diameter wear limit criteria. Replaced fluid MIL-PRF-5606 with MIL-PRF-87257 and bleed kit 212-014-01 with 212-014-02.
7	11/08/17	Section 5 page 1	Added reference to Component Maintenance Manual 122-015-00 for annual/100 hour inspection.
8	12/12/18	Section 5 pages 4 and 5	Removed NDT of parts, inserted instructions to return pin load cell to factory, updated inspection criteria table (Table 5.1.2).
9	07/30/19	Section 11, Section 25 pages 2, 3, and 5 thru 23	Added C-40 Indicator and associated instructions.

THIS PAGE INTENTIONALLY LEFT BLANK

List of Effective Pages

Title	Pages	Revision	Date
Cover	i, ii Blank	9	07/30/19
Record of Revisions	iii, iv Blank	9	07/30/19
List of Effective Pages	v, vi Blank	9	07/30/19
Table of Contents	vii, viii	9	07/30/19
Section 0 Introduction	1	5	02/05/16
Section 0 Introduction	2	3	11/20/13
Section 4 Airworthiness Limitations	1, 2 Blank	3	11/20/13
Section 5 Inspection and Overhaul Schedule	1	7	11/08/17
Section 5 Inspection and Overhaul Schedule	2, 3	5	02/05/16
Section 5 Inspection and Overhaul Schedule	4, 5	8	12/12/18
Section 5 Inspection and Overhaul Schedule	6	2	05/01/12
Section 11 Placards and Markings	1, 2	9	07/30/19
Section 12 Servicing	1, 2	6	09/13/17
Section 12 Servicing	3, 4	1	12/19/11
Section 12 Servicing	5	6	09/13/17
Section 12 Servicing	6	0	07/13/11
Section 12 Servicing	7	6	09/13/17
Section 12 Servicing	8, 9	0	07/13/11
Section 12 Servicing	10	4	08/21/15
Section 12 Servicing	11, 12 Blank	0	07/13/11
Section 25 Equipment and Furnishings	1	0	07/13/11
Section 25 Equipment and Furnishings	2, 3	9	07/30/19
Section 25 Equipment and Furnishings	4	5	02/05/16
Section 25 Equipment and Furnishings	5 thru 23	9	07/30/19

THIS PAGE INTENTIONALLY LEFT BLANK

CONTENTS

<u>Identification</u>	<u>Title, Page</u>
<i>Section 0</i>	Introduction
	0.4 Scope, 1
	0.5 Purpose, 1
	0.6 Arrangement, 1
	0.7 Applicability, 1
	0.9 Abbreviations, 1
	0.12 Precautions, 2
	0.19 Distribution of Instructions for Continued Airworthiness, 2
<i>Section 4</i>	Airworthiness Limitations
<i>Section 5</i>	Inspection and Overhaul Schedule
	5.1 Cargo Hook Kit Inspection, 1
	5.2 Cargo Hook Overhaul Schedule, 6
<i>Section 11</i>	Placards and Markings
	11.1 Placards, 1
<i>Section 12</i>	Servicing
	12.1 Maintenance of the Hydraulic Release System, 1
	12.2 Bleeding Hydraulic System, 5
	12.3 Lubrication Information, 10
<i>Section 25</i>	Equipment and Furnishings
	25.1 Cargo hook connector, 1
	25.2 Description, 2
	25.5 Component Weights, 4
	25.12 Storage Instructions, 4
	25.15 Troubleshooting, 5
	25.16 Component Removal, 11
	25.17 Component Re-installation, 16
	25.18 General Procedures Instructions-Testing, 23

Figures

- 5.1.1 Hook Lock Indicator, Section 5 Page 2
- 5.1.2 Components/Disassembly, Section 5 Page 3
- 12.1.1 Checking Hydraulic Fluid Level, Section 12 Page 1
- 12.1.2 Master Cylinder Lever Disconnect, Section 12 Page 2
- 12.1.3 Master Cylinder Piston Removal, Section 12 Page 3
- 12.1.4 Master Cylinder Piston Seal Orientation, Section 12 Page 3
- 12.1.5 Slave Cylinder Piston Removal, Section 12 Page 4
- 12.2.1 Hydraulic Hook Bleed Kit Section 12 Page 5
- 12.2.2 Hose Arrangement, Section 12 Page 6
- 12.2.3 Reservoir Disassembly, Section 12 Page 6
- 12.2.4 Screw and Stat-o-seal Removal, Section 12 Page 7
- 12.2.5 Injecting Hydraulic Fluid, Section 12 Page 7
- 12.2.6 Screw Re-installation, Section 12 Page 8
- 12.2.7 Checking System for Air, Section 12 Page 9
- 12.3.1 Lubrication Points, Section 12 Page 10
- 25.2.1 Kit Overview – P/N 200-378 series, Section 25 Page 3
- 25.2.2 Kit Overview – P/N 200-379 series, Section 25 Page 3
- 25.15.1 Cargo Hook Electrical Connector, Section 25 Page 7
- 25.15.2 Wire Harness Routing, Section 25 Page 8
- 25.15.3 Electrical Schematic, Section 25 Page 8
- 25.15.4 CAL Code, Section 25 Page 9
- 25.15.5 C-40 Settings Screen, Section 25 Page 9
- 25.15.6 Changing Dampening Level, Section 25 Page 9
- 25.16.1 Attach Point Assembly Removal, Section 25 Page 11
- 25.16.2 Slave Cylinder Assembly Removal, Section 25 Page 12
- 25.16.3 Master Cylinder and Plumbing Installation, Section 25, Page 13
- 25.16.4 Master Cylinder Removal, Section 25, Page 14
- 25.17.1 Attach Point Assembly Re-installation, Section 25, Page 16
- 25.17.2 Cargo Hook Orientation, Section 25, Page 17
- 25.17.3 Cargo Hook Attachment Hardware, Section 25, Page 18
- 25.17.4 Cargo Hook Attachment w/ Pin Load Cell, Section 25 Page 18
- 25.17.5 Slave Cylinder Assembly Installation, Section 25 Page 19
- 25.17.6 Hydraulic Hose & Electrical Harness Routing, Section 25 Page 20
- 25.17.7 External Hose and Harness Routing, Section 25 Page 21
- 25.17.8 Lever Adjustment, Section 25 Page 22

Tables

- 5.1.1 Cargo Hook Kit Parts, Section 5 Page 4
- 5.1.2 Cargo Hook Kit Inspection Criteria, Section 5 Page 5
- 11.1 Cargo Hook Kit Placards, Section 11 Page 1
- 25.1.1 Cargo Hook Connector, Section 25 Page 1
- 25.5.1 Component Weights and CGs, Section 25 Page 4
- 25.15.1 Troubleshooting, Section 25 Page 5

Section 0

Introduction

0.4 Scope

The following information is necessary to carry out the service, maintenance, and inspection of the Cargo Hook Kit P/Ns 200-378-00, 200-378-10, 200-379-00, 200-379-01, 200-379-10, and 200-379-11 (these kits P/N series are also referred to as 200-378-XX and 200-379-XX respectively). See Section 25.2 for a detailed description of these kits.

0.5 Purpose

The purpose of this Instructions for Continued Airworthiness (ICA) manual is to provide the information necessary to inspect, service, and maintain the cargo hook kits in an airworthy condition.

0.6 Arrangement

This manual contains instructions for the service, maintenance, inspection and operation of the cargo hook kits listed above on MD Helicopters 369 series and 500N model helicopters. The manual is arranged in the general order that maintenance personnel would use to install, maintain and operate the Cargo Hook Kits in service.

The arrangement is:

- Section 0 Introduction.
- Section 4 Airworthiness limitations (None apply to this System.)
- Section 5 Inspection and overhaul schedule
- Section 11 Placards and Markings
- Section 12 Servicing
- Section 25 Equipment and Furnishings

0.7 Applicability

These Instructions for Continued Airworthiness are applicable to Cargo Hook Kit P/Ns 200-378-XX and 200-379-XX for the MD Helicopter 369 series and 500N model helicopters. Refer to the appropriate MD Helicopter maintenance documentation for instructions regarding parts of the aircraft that interface with these kits.

0.9 Abbreviations

- FAA Federal Aviation Administration
- FAR Federal Aviation Regulation
- ICA Instructions for Continued Airworthiness
- CMM Component Maintenance Manual

0.12 Precautions

The following definitions apply to safety labels used in this manual.



Indicates a hazardous situation which, if not avoided, will result in death or serious injury.



Indicates a hazardous situation which, if not avoided, could result in death or serious injury.



Indicates a hazardous situation which, if not avoided, could result in minor or moderate injury.



Draws the reader's attention to important or unusual information not directly related to safety.



Used to address practices not related to personal injury.

0.19 Distribution of Instructions for Continued Airworthiness

Before performing maintenance ensure that the Instructions for Continued Airworthiness (ICA) in your possession is the most recent revision. Current revision levels of all manuals are posted on Onboard Systems Int'l web site at www.onboardsystems.com.

Onboard Systems offers a free notification service via fax or e-mail for product alerts and documentation updates. By registering Onboard Systems products on the web site, we will be able to contact you if a service bulletin is issued, or if the documentation is updated.

Notices can be chosen to be received on an immediate, weekly, or monthly schedule via fax, email or both methods. There is no charge for this service. Please visit the Onboard Systems web site at www.onboardsystems.com/notify.php to get started.

Section 4

Airworthiness Limitations

The Airworthiness Limitations section is FAA approved and specifies inspections and other maintenance required under Secs. 43.16 and 91.403 of the Federal Aviation Regulations unless an alternative program has been FAA approved.

No airworthiness limitations are associated with this type design change.

THIS PAGE INTENTIONALLY LEFT BLANK

Section 5

Inspection and Overhaul Schedule

5.1 Cargo Hook Kit Inspection

The scheduled inspection intervals noted below are maximums and are not to be exceeded. If the cargo hook is subjected to unusual circumstances, extreme environmental conditions, etc., it is the responsibility of the operator to perform the inspections more frequently to ensure proper operation.

Annually or 100 hours of external load operations (see section 5.2 for definition), whichever comes first, inspect the cargo hook kit per the following. Refer also to the cargo hook's Component Maintenance Manual (manual no. 122-015-00) for additional inspection.

1. Activate the electrical system and press the Cargo Release button on the cyclic to ensure the cargo hook electrical release system is operating correctly. The cargo hook must release. Reset the hook by hand after release.



Depressing the cargo release button continuously in excess of 20 seconds will cause the cargo hook solenoid to overheat, possibly causing permanent damage.

The following instructions are applicable to cargo hook P/N 528-028-02 which is equipped with Surefire electrical release. With no load on the cargo hook perform the following.

- Very briefly press the Cargo Release switch, the cargo hook should not actuate and the load beam should remain closed.
 - Press and hold the Cargo Release switch for a few seconds, the load beam should fall to the open position and the cargo hook solenoid should continue to cycle repeatedly.
 - Push up on the load beam and verify that it latches and the hook lock indicator is aligned with the engraved line on the manual release cover.
2. Activate the hydraulic release system by pulling the release lever on the cyclic. The lever should operate smoothly and the cargo hook must release. Return the load beam to its closed and locked position by hand after release. Verify that the hook lock indicator on the side of the hook returns to the fully locked position. In the fully locked position the hook lock indicator must align with the lines on the cover (see Figure 5.1.1).

5.1 Cargo Hook Kit Inspection continued

Figure 5.1.1 Hook Lock Indicator

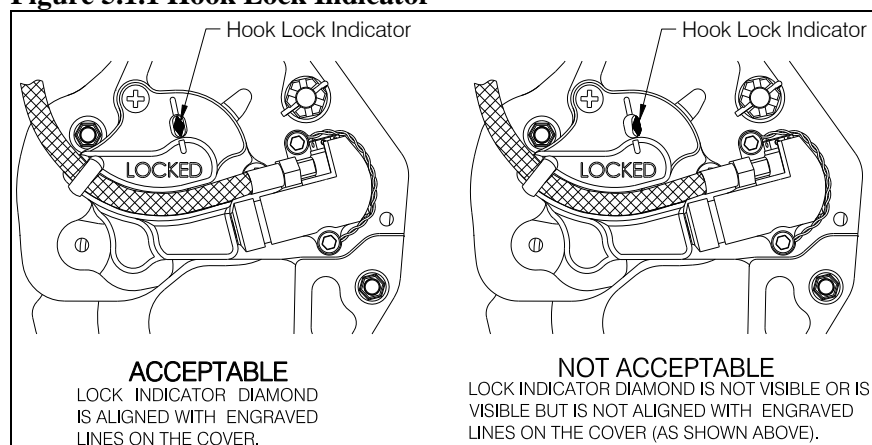

3. Move the cargo hook throughout its full range of motion and observe the hydraulic hose and electrical harnesses to ensure that they have enough slack. The hose or harnesses must not be the stops that prevent the cargo hook from moving freely in all directions.
4. Rotate all pivoting joints to ensure that they rotate freely throughout their range of motion.
5. Visually inspect for presence and security of fasteners.
6. Visually inspect the external electrical harnesses and their connectors for damage and security.
7. Visually inspect the external hydraulic hose and its connection to the cargo hook for damage and security.
8. Visually inspect for cracks and damage in the attach point assembly.
9. Visually inspect for security of the load indicator mounting (if load weigh system is installed).
10. Visually check for fluid leaks in the hydraulic release system. Some seeping or dampness is acceptable, but if drips or areas cleaned by fluid leaking are present the hook must not be used until the condition is repaired. See troubleshooting section to determine the course of action.
11. Check the fluid level in the master cylinder on the cyclic. The master cylinder features a transparent lid through which the fluid level can be checked. Hydraulic fluid must be visible over the baffle surface (reference Figure 12.1.1).
12. Check the hydraulic release system for air by pulling the lever firmly until it bottoms out. Check the push rod position (reference Figure 12.2.7). If some of the green ring on the push rod is visible, the system is adequately bled. If some of the green on the push rod is NOT visible with the lever completely pulled, the system has too much air in it and must be bled, see Section 12.2 for bleeding instructions.

5.1 Cargo Hook Kit Inspection continued

Every 1000 hours of external load operations or 5 years, whichever comes first, remove the load bearing components from the helicopter, disassemble, and inspect the parts per the following instructions.

1. Disconnect the electrical release harness and the slave cylinder/plumbing assembly.
2. Remove the cotter pin (14) from the nut (13) and remove nut and washers (11 and 12) from the end of the pin load cell (15) if the load weigh system is installed. If kit P/N 200-378 series is installed the pin load cell is replaced by Attach Bolt P/N 290-332-00 and washer P/N 510-183-00 under the bolt head.
3. Remove the pin load cell, separating it and the cargo hook from the Pivot Link Assembly (6, 7, and 8). The Pivot Link Assembly does not need to be disassembled unless the bushings exceed wear limits.
4. Cut safety wire and remove the four bolts (10) and washers (9) to remove the remaining components from the helicopter.
5. Separate the Pivot Link Assembly from the Pillow Block (2) by removing cotter pin (5), nut (4), and bolt (3).

Figure 5.1.2 Components/Disassembly

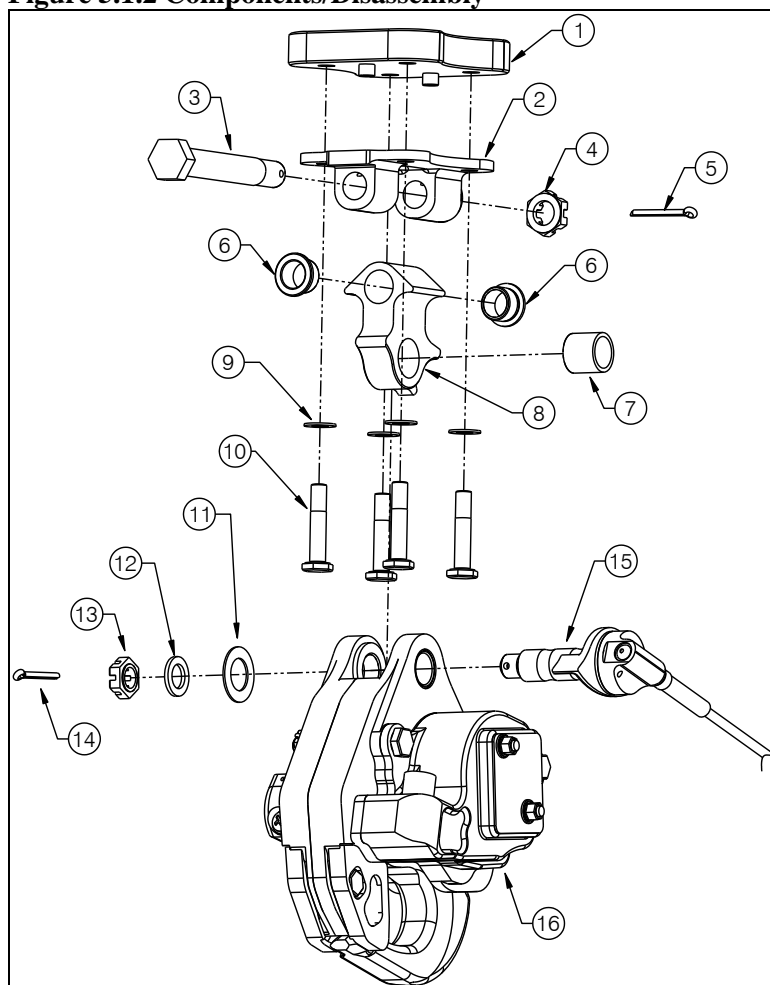

5.1 Cargo Hook Kit Inspection continued

Table 5.1.1 Cargo Hook Kit Parts

Item	Part No.	Description	Qty
1	232-456-00	Spacer Assembly	1
2	291-483-00	Pillow Block	1
3	510-142-00	Bolt	1
4	510-108-00	Nut	1
5	510-222-00	Cotter Pin	1
6	291-486-00	Flanged Bushing	2
7	290-364-00	Bushing	1
8	291-484-01**	Pivot Link	1
9	510-100-00	Washer	4
10	510-308-00	Bolt	4
11	510-183-00*	Washer	2
12	510-174-00	Washer	1
13	510-170-00	Nut	1
14	510-178-00	Cotter Pin	1
15	210-226-03*	Pin Load Cell	1
16	232-203-00	Cargo Hook/Slave Cylinder	1
	232-203-02***	Cargo Hook/Slave Cylinder w/ Surefire	

* If kit P/N 200-378 series is installed, the pin load cell is replaced by attach bolt P/N 290-332-00 with a washer, P/N 510-183-00, installed under the bolt head (ref. Figure 25.17.3). P/N 210-226-03 (shown in Figure 5.1.2) is superseded by P/N 210-301-03. These P/Ns are interchangeable.

** Supersedes P/N 291-484-00. P/N 291-484-01 provides compatibility with the Onboard Systems E-51 load cell assembly, otherwise these can be interchanged.

*** Cargo Hook with Surefire is included with Kit P/Ns 200-378-10, 200-379-10, and 200-379-11.

5.1 Cargo Hook Kit Inspection continued

- Carefully inspect, and if necessary repair, the detail parts in accordance with the instructions in Table 5.1.2. Refer to Figure 5.1.2 for part identification. Inspect the parts in a clean, well-lit room. Repair parts found within inspection limits. Replace any part found beyond limits.
- If Pin Load Cell Assembly is present return it to the factory for inspection and calibration. The factory will inspect the condition of the load cell and perform acceptance test procedures including calibration and zero balance, repairing as necessary.
- The Load Indicator requires no maintenance. Do not open the enclosure, return to the factory if in need of repair.

Table 5.1.2 Cargo Hook Kit Inspection Criteria

Seq.	Component	Inspection Criteria and Limit	Repair Action	Finish
1.	Pillow Block (2) Pivot Link (8)	Nicks, dents, scratches, corrosion – 0.010 in. (0.254 mm) deep	Blend at 10:1 ratio as required to provide smooth transitions. Glass bead blast at less than 30 PSI (2.11 KGF/CM ²) to remove corrosion.	Passivate per AMS-QQ-P-35 or ASTM A967.
		Any indication of cracks.	None	N/A
2.	Bolt (3)	Wear on OD – 0.428 in. (10.87 mm)	None	N/A
3.	Flanged Bushing (6)	Wear on ID – 0.450 in. (11.43 mm)	None	N/A
4.	Bushing (7)	Wear on ID – 0.520 in. (13.21 mm)	None	N/A
5.	Attach Bolt or Pin Load Cell (15)	Wear on OD – 0.495 in. (12.57 mm)	None	N/A
6.	Spacer Assembly (1)	Dents, nicks, cracks, gouges, scratches and corrosion – 0.020 in. (0.50 mm) deep	Blend at 10:1 ratio as required to provide smooth transitions.	Apply Alodine (MIL-DTL-5541) and zinc chromate primer (MIL-PRF-23377 or similar) to affected surfaces.
7.	Cargo Hook (16)	Refer to CMM 122-015-00 for inspection and overhaul instructions for the cargo hook.		
8.	Remaining bolts, nuts, washers, cotter pins.	Wear, corrosion, or deterioration.	None	N/A

5.2 Cargo Hook Overhaul Schedule

Time Between Overhaul (TBO): 1000 hours of external load operations or 5 years, whichever comes first.

NOTICE

*Hours of external load operations should be interpreted to be (1) anything is attached to the primary cargo hook (whether or not a useful load is being transported) and (2) the aircraft is flying. If these conditions are **NOT** met, time does **NOT** need to be tracked.*

Overhaul the cargo hook per CMM 122-015-00. Contact Onboard Systems for guidance to locate authorized overhaul facilities.



Section 11

Placards and Markings

11.1 Placards

The Cargo Hook Kits include the following placards pertaining to the load weigh system shown in Table 11.1. The 200-378-XX and 200-379-XX kits also use the helicopter's existing cargo hook placards. Reference MD Helicopter's maintenance manuals for their identification and location.

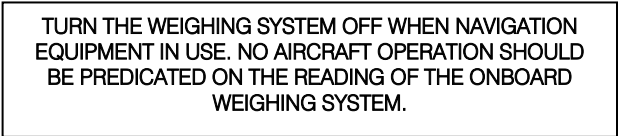
Table 11.1 Cargo Hook Kit Placards

Placard part number and appearance	Location
<p>P/N 215-010-00</p> 	<p>When the optional load weigh system is installed, mounted adjacent to both the power switch (if present) and the circuit breaker in view of the pilot and co-pilot.</p>
<p>P/N 215-012-00</p> 	<p>When the optional load weigh system with C-39 model Load Indicator (P/N 210-095-00 or P/N 210-095-04) is installed, mounted adjacent to the load weigh indicator in full view of the pilot and co-pilot.</p>
<p>P/N 215-336-00</p> 	<p>Mounted on the bottom of solenoid housing of cargo hook P/N 528-028-02 (included with kit P/Ns 200-378-10, 200-379-10 and 200-379-11 only).</p>
<p>P/N 215-343-00</p> 	<p>Located adjacent to the cargo hook release switch on the cyclic (included with kit P/Ns 200-378-10, 200-379-10 and 200-379-11 only).</p>

This page intentionally left blank.

Section 12

Servicing

12.1 Maintenance of the Hydraulic Release System

The system is filled with fluid at installation and does not consume fluid unless it leaks out. If any leakage is detected, the fluid level should be immediately checked.

NOTICE

MIL-PRF-5606 and MIL-PRF-87257 fluids are both compatible with the hydraulic system. These fluids are interchangeable and miscible.

To check the fluid level:

1. If possible, position the cyclic such that the reservoir is level.
2. The Master Cylinder features a transparent lid through which the fluid level can be checked. Hydraulic fluid must be visible over the baffle surface (see Figure 12.1).
3. If necessary, remove lid and add hydraulic fluid as required until the fluid level is just over the baffle surface. When re-installing lid do not over-tighten screws.

Figure 12.1.1 Checking Hydraulic Fluid Level

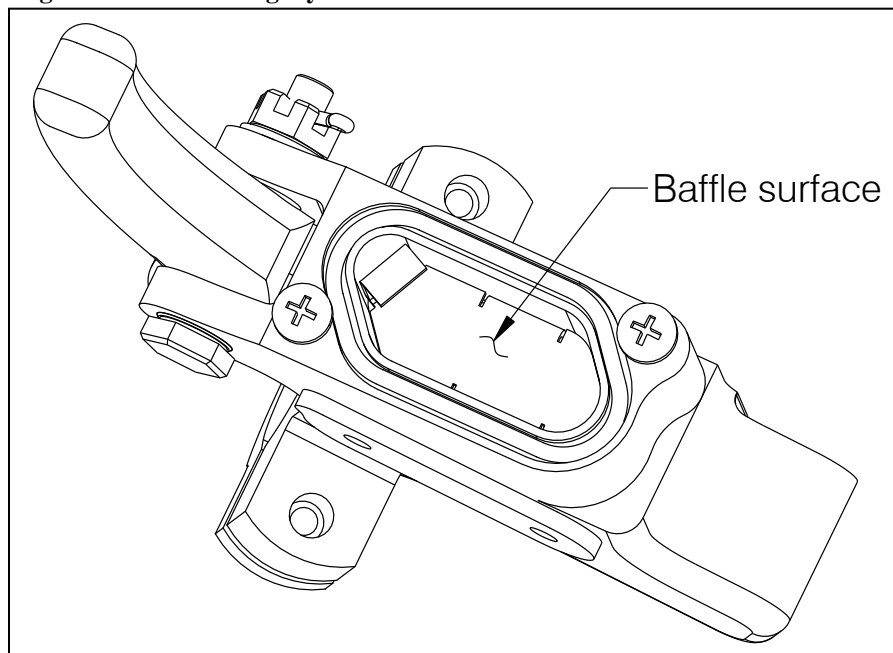

If leakage is noted around any plumbing fittings, the fittings may be tightened until the leakage quits. If leakage is noted around the pistons in either the master or slave cylinders the leaking cylinder must be repaired. See the instructions for repair in this Section.

12.1 Maintenance of the Hydraulic Release System, continued

Master Cylinder Repair

If fluid is leaking around the piston, the only repair is to remove and replace the cup seal and O-ring. The master cylinder must be disassembled, inspected and then re-assembled with new seals.

Disassembly:

1. Remove snap ring. Use caution when removing snap ring since the piston is spring loaded against the washer and snap ring. The piston will pop out of the housing when the snap ring is removed. Use the lever to put pressure on the piston while removing snap ring.
2. Loosen the set screw and disconnect barrel nut on lever. See Figure 12.1.2.
3. Remove the piston and spring. See Figure 12.1.3 for parts breakdown.
4. Inspect the master cylinder bore for scratches. If any scratches or gouges are visible in the bore, the master cylinder must be replaced.

Re-assembly

1. If the bore condition is acceptable, replace the cup seal and O-ring on the piston assembly. Orient the cup seal as shown in Figure 12.1.4. Stretch seals over piston into grooves.
2. Lubricate the piston seals and cylinder bore generously with hydraulic fluid.
3. Place the spring in the cylinder bore.
4. Pass the push rod through the washer.
5. Thread the push rod into the barrel nut until approximately 1/16" of thread is visible through the opposite side of the barrel nut.
6. Insert the small spring into the piston assembly and insert the piston assembly into the master cylinder bore using a firm rocking motion.
7. Use the lever to compress the spring and hold the piston in place.
8. Use snap ring pliers to install the snap ring.
9. Secure push rod threads by tightening set screw.

Figure 12.1.2 Master Cylinder Lever Disconnect

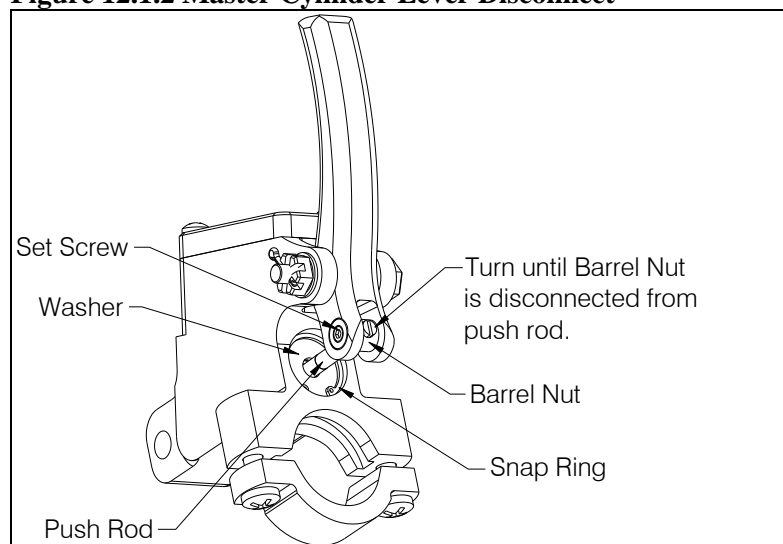

12.1 Maintenance of the Hydraulic Release System, continued

Master Cylinder Repair continued

Figure 12.1.3 Master Cylinder Piston Removal

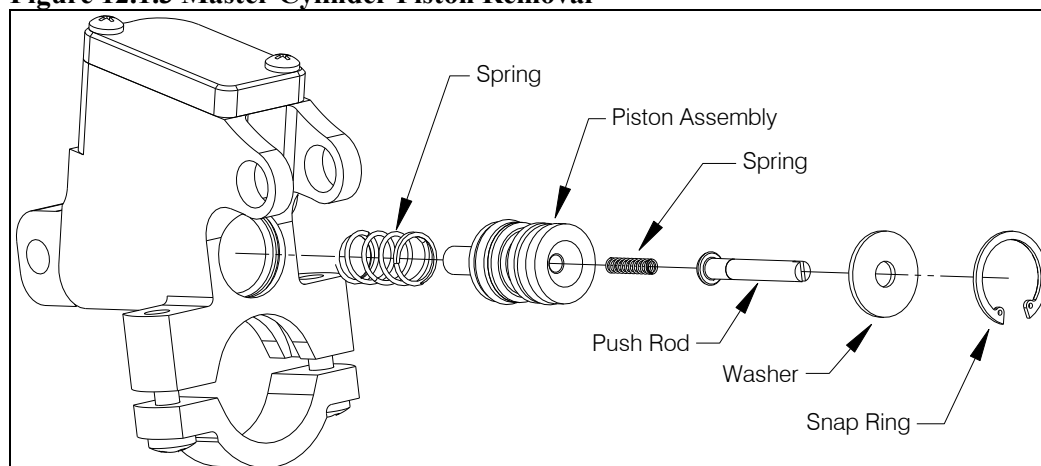
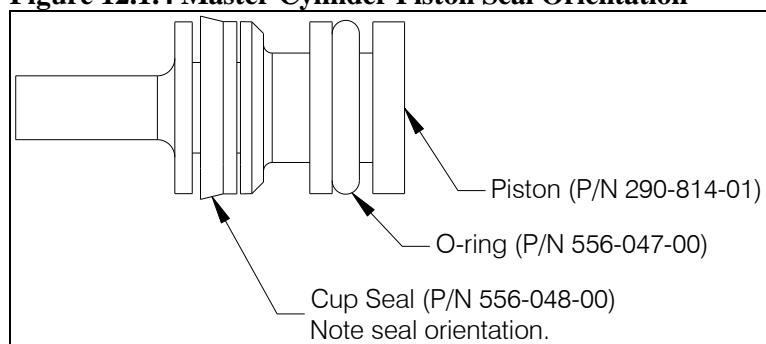

Figure 12.1.4 Master Cylinder Piston Seal Orientation



Slave Cylinder Repair

If the slave cylinder is leaking fluid around the piston rod, the only repair possible is to remove and replace the quad ring or cup seal (earlier production units of the slave cylinder assembly used a cup seal instead of the quad ring).

Disassembly:

1. Remove cap, piston, and seal (see Figure 12.1.5).
2. Inspect bore of slave cylinder for scratches or gouges. If any are present the assembly must be replaced.
3. Remove bushing in cap by pressing it out.
4. Remove quad ring (or cup seal) by stretching it over the piston.

Re-assembly:

1. Press new bushing into cap.
2. Stretch new quad ring over piston into groove.
3. Clean and lubricate cylinder bore and piston seal with hydraulic fluid.
4. Insert piston into cylinder taking care not to damage edges of quad ring.
5. Screw on cap and torque to 50-60 in-lbs.

12.1 Maintenance of the Hydraulic Release System, continued

Slave Cylinder Repair continued

Figure 12.1.5 Slave Cylinder Piston Removal

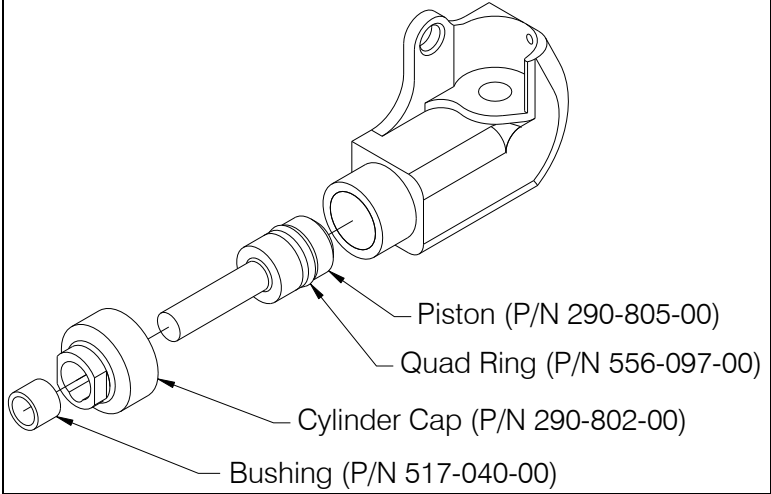

12.2 Bleeding Hydraulic System

Filling and bleeding the hydraulic release system is most easily accomplished on the bench, prior to installation on the aircraft. This process may also be accomplished after the system is installed. Filling and bleeding requires two persons, one to inject hydraulic fluid through the system and the other to observe the reservoir.

Bleeding procedure:

1. Obtain the hydraulic hook bleed kit, 212-014-02 (optional: 212-014-01). This kit consists of 2 ounces of MIL-PRF-87257 fluid, a syringe, a female barb fitting, a length of PVC tubing, and a bleed adapter fitting. The bleed kit is included in new hook kits. Assemble the bleed kit by press fitting each component as shown.

Figure 12.2.1 Hydraulic Hook Bleed Kit

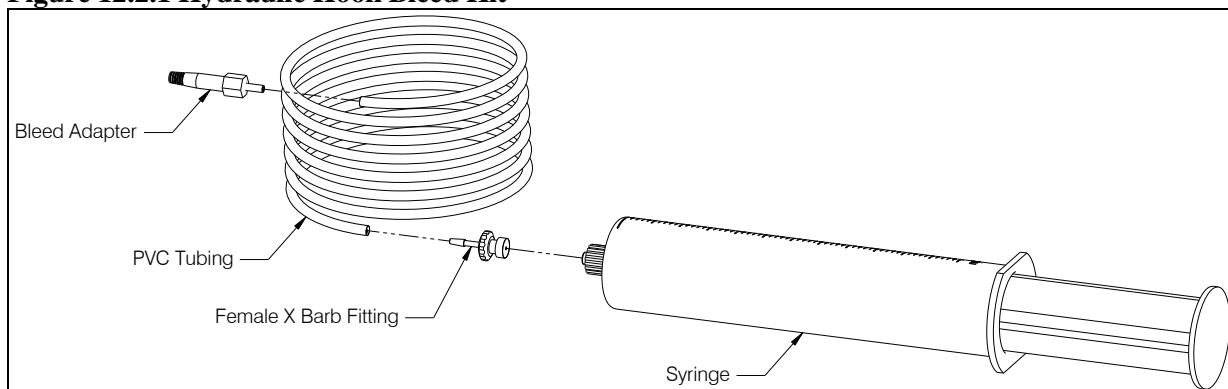

2. If the system is already installed on the aircraft, place an absorbent towel under the master cylinder. If the master cylinder is not installed on the aircraft, lightly clamp the master cylinder in a vise to hold it in a vertical position and position the slave cylinder so that its level is below the level of the master cylinder.

NOTICE

Use best shop practices to keep foreign material out of the hydraulic system. FOD will plug orifices, damage seals and/or scratch sealing surfaces necessitating system rebuild. Use only clean hydraulic fluid from sealed containers.

12.2 Bleeding Hydraulic System, continued

3. Connect the master cylinder assembly to the slave cylinder assembly if not already done. If filling or bleeding on the bench, as much as possible, arrange the hoses uncoiled, straight and running uphill.

Figure 12.2.2 Hose Arrangement

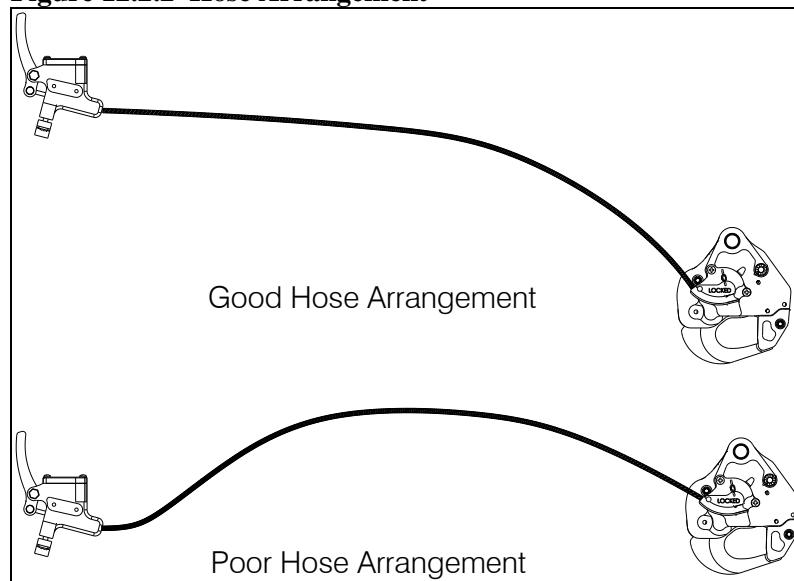

4. Remove screws, reservoir lid, and baffle from the master cylinder reservoir as shown in Figure 12.2.3.

Figure 12.2.3 Reservoir Disassembly

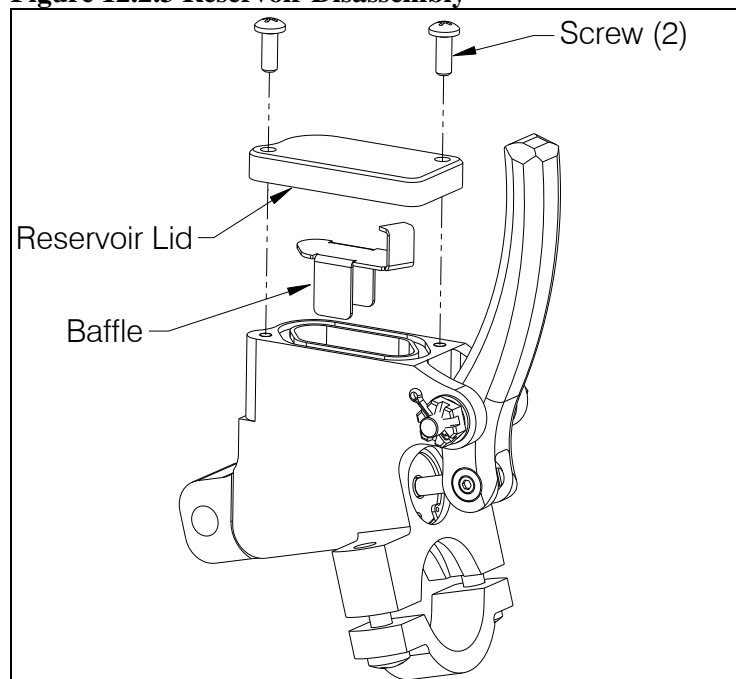

12.2 Bleeding Hydraulic System, continued

5. Remove the screw and stat-o-seal on the slave cylinder, see Figure 12.2.4.

Figure 12.2.4 Screw and Stat-o-seal Removal

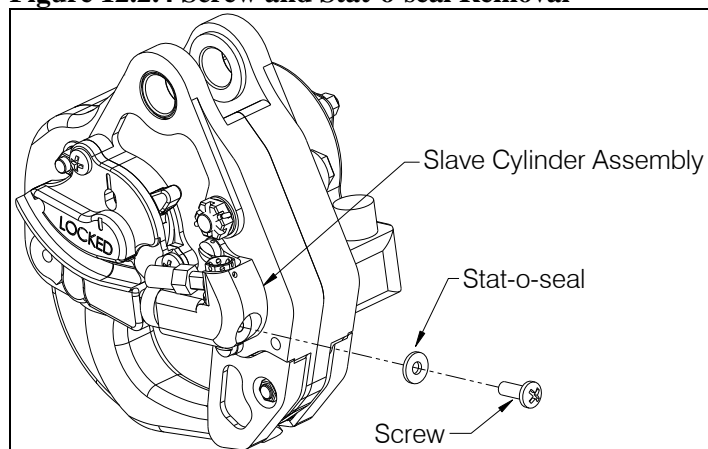

6. Fill the syringe with approximately 35 cc of hydraulic fluid and purge any remaining air in the syringe and tubing. Screw the end of the bleed adapter into the screw hole on the slave cylinder to create a tight seal. See Figure 12.2.5.
7. While observing the reservoir, **slowly** push on the syringe plunger to force fluid through the slave cylinder, hydraulic hose, and up to the master cylinder reservoir. There will be some resistance during filling—this is normal.



Injecting the fluid into the system too rapidly may cause the fluid to spray up and out of the master cylinder reservoir. Wear safety glasses when observing fluid reservoir while filling.

Figure 12.2.5 Injecting Hydraulic Fluid

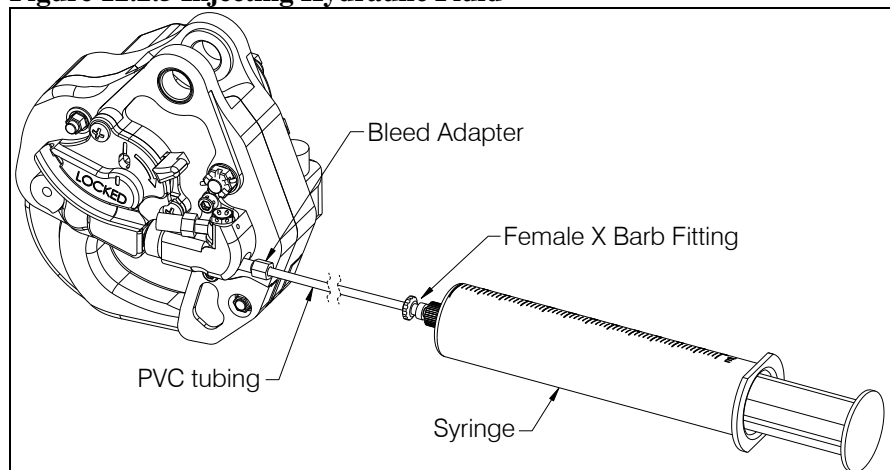

12.2 Bleeding Hydraulic System, continued

- Continue to force fluid into the master cylinder reservoir until the reservoir is approximately half full.

NOTICE

If bleeding an already filled system, you may need to draw fluid from the master cylinder reservoir during this step to prevent overflow.

- Remove the bleed adapter from the screw hole. Re-install the Stat-O-Seal (P/N 510-496-00) and screw (P/N 510-493-00), see Figure 12.2.6.

Figure 12.2.6 Screw Re-installation

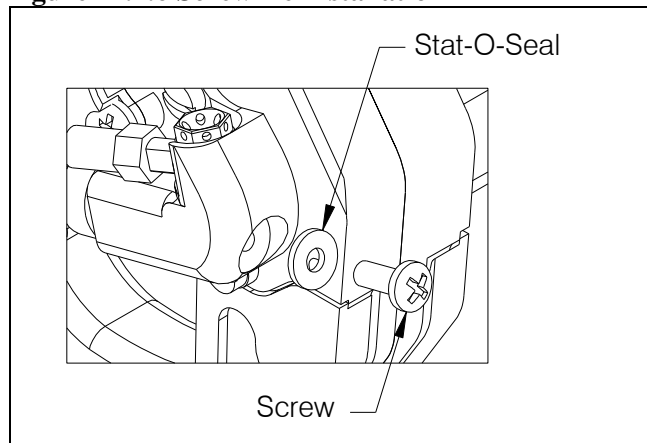

- Allow the system to rest for several minutes. This will allow any air to rise through the system.
- Very **slowly** pull the release lever on the master cylinder and watch for bubbles. If bubbles are observed rising within the reservoir, continue to slowly cycle the lever until there are no more. Actuating the lever releases air trapped within the master cylinder.

12.2 Bleeding Hydraulic System, continued



Pull the lever very slowly! When the reservoir is not baffled and capped, a hard pull will cause fluid to erupt over the edge of the reservoir.

12. Check the system for air by actuating the lever firmly until it bottoms out. Check the push rod position (see Figure 12.2.7). If some of the green ring on the push rod is visible, proceed to step 13. If some of the green on the push rod is not visible with the lever completely pulled, the system has too much air in it and needs further bleeding. To do this, repeat steps 5 – 11.

Figure 12.2.7 Checking System for Air

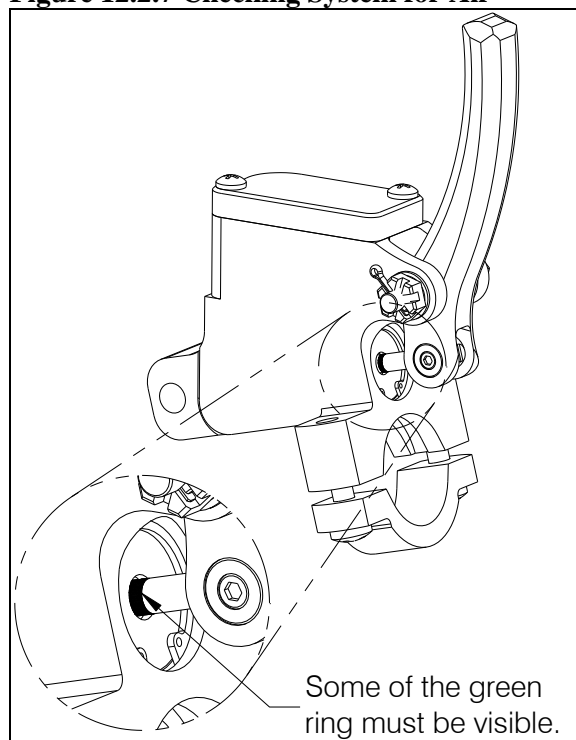

13. After the system is properly bled, verify that the reservoir is approximately half full of hydraulic fluid. Fluid should be visible above the baffle.
14. Re-install the baffle, and the reservoir lid.
15. Check the system for proper operation. Fully actuate the release lever. The hook must open and the lever must have a firm feel.
16. Disassemble and thoroughly clean the bleed kit with isopropyl alcohol. Allow it to dry. Not cleaning the syringe will render it unusable. Reassemble and store for next use.

12.3 Lubrication Information

Lubrication of Cargo Hook and linkage pivot points is recommended every 500 hours of external load operation.

Lubricate the pivot points illustrated in Figure 12.3.1 (Note: if the load weigh system is installed the attach bolt (shown in figure) at the cargo hook is replaced by the pin load cell). Recommended lubricants are AeroShell 17 (MIL-G-21164) or Mobilgrease 28 (MIL-G-81322).

For re-assembly after lubrication, tighten nuts to finger tight until fully seated then rotate to previous castellation if necessary to install cotter pin.



Do not tighten nut on pin load cell (if installed) more than finger tight. Over-tightening will damage load cell.

Figure 12.3.1 Lubrication Points

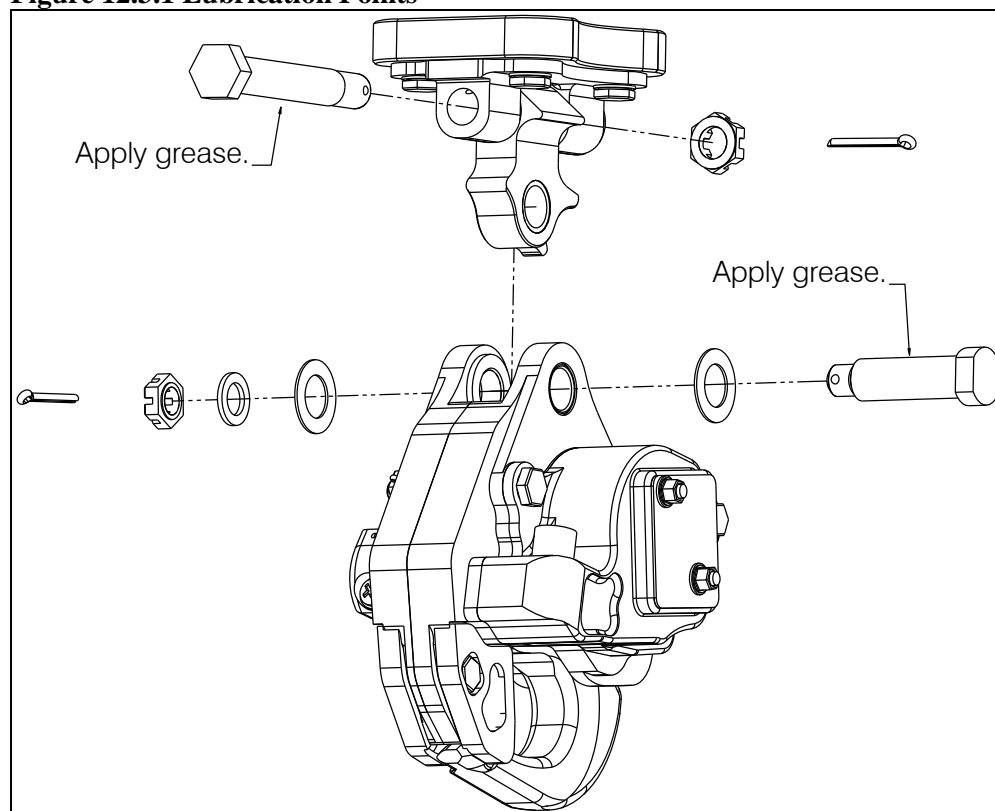

12.3 Lubrication Information, continued

Hook Corrosion Prevention

In marine or other corrosive environments the life of the hook can be increased by periodically treating with a corrosion preventative compound such as ACF-50. Spray exterior of hook with corrosion preventative compound and wipe off excess with a rag.

The amount and frequency of application will vary depending on climate. In dry dusty environments it is not recommended to treat for corrosion since the oily residue on the inside of the cargo hook that cannot be wiped off could attract and retain dust and sand. In addition corrosion is not likely to be a problem in these conditions. For offshore or coastal operations, treatment could be done every two weeks.

THIS PAGE INTENTIONALLY LEFT BLANK

Section 25

Equipment and Furnishings

25.1 Cargo Hook Connector

Listed below is the pin out for the cargo hook connector. The hook is polarity sensitive due to an arc suppressing diode internally mounted.

Table 25.1.1 Cargo Hook Connector

<i>Pin</i>	<i>Function</i>
A	Ground
B	Power

25.2 Description

The P/N 200-378-00 and -10 kits include the cargo hook, an external electrical release harness that connects to the existing helicopter wiring provisions, an attach point assembly, and a hydraulic release system. The hydraulic release system replaces the existing manual release cable system on the aircraft. It includes a release lever assembly with a small reservoir which attached to the cyclic in the cockpit, associated plumbing routed to a disconnect point near the belly of the aircraft, and plumbing from this disconnect to a slave cylinder on the cargo hook. The attach point assembly bolts to the bottom of the helicopter and provides the mounting point for the cargo hook and has provisions to allow the cargo hook to pivot side to side and fore and aft.

The P/N 200-379-00 and 200-379-10 kit configurations are identical to the 200-378-00 and 200-378-10 respectively except they include a load weigh system. The load weigh system includes a pin load cell mounted at the cargo hook attach point, a load indicator in the cockpit, and associated electrical harness. Kits with load weigh systems shipped September 2019 and later include the next generation C-40 Load Indicator (P/N 210-293-00). The P/N 200-379-01 and P/N 200-379-11 are identical to 200-379-00 and 200-379-11 respectively except they include a C-39 model load indicator with NVG lights.

The external electrical release cable in combination with the existing fixed helicopter wiring forms the electrical release system which provides a means to release a cargo hook load through the use of a switch in the cockpit.

The P/N 200-378-10, 200-379-10, 200-379-11 cargo hook kits include cargo hook P/N 528-028-02 with Surefire Release which includes a time delay circuit built into the cargo hook's electrical release system. This feature is a safety enhancement to protect against inadvertent load release due to accidental contact with the cargo release switch or mistaken actuation of the release switch when another is intended. Surefire makes the electrical release a more deliberate pilot command by requiring that the release switch be depressed and held for more than a 1/2 second to open the cargo hook. In addition to its P/N, a cargo hook with Surefire can be identified by a gold anodized solenoid housing and a placard on the underside of the solenoid housing that specifies that the electrical release is delayed ½ second.

The hydraulic release system provides a backup means to release a cargo hook load in the event of an electrical system failure.

Figures 25.2.1 and 25.2.2 show the primary components that make up these cargo hook kits. Miscellaneous items, hardware, etc. are not shown.

25.2 Description continued

Figure 25.2.1 Kit Overview – P/N 200-378 Series

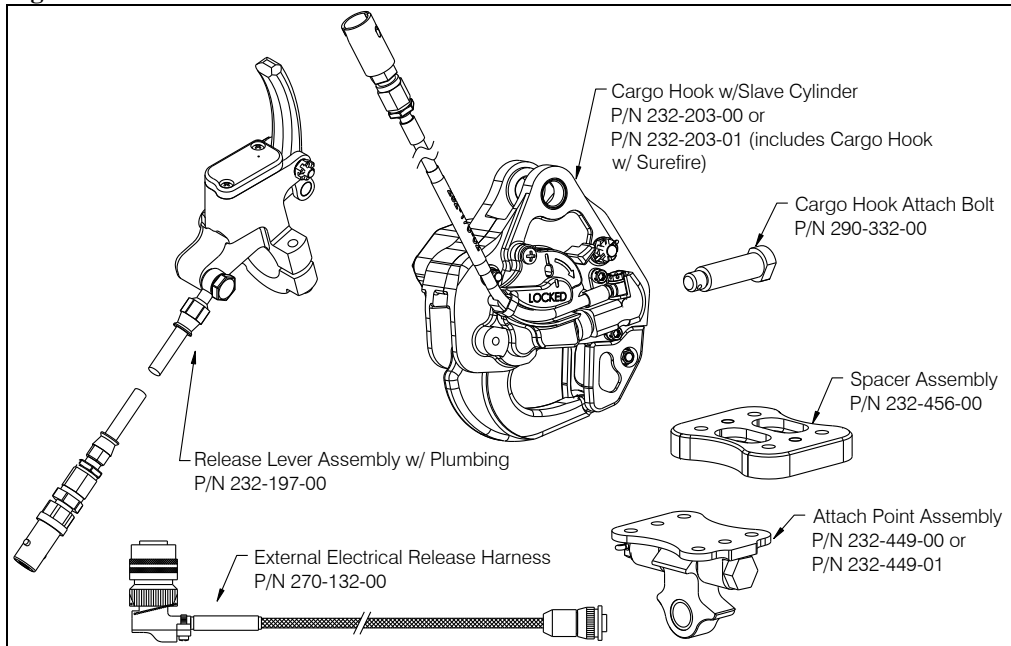
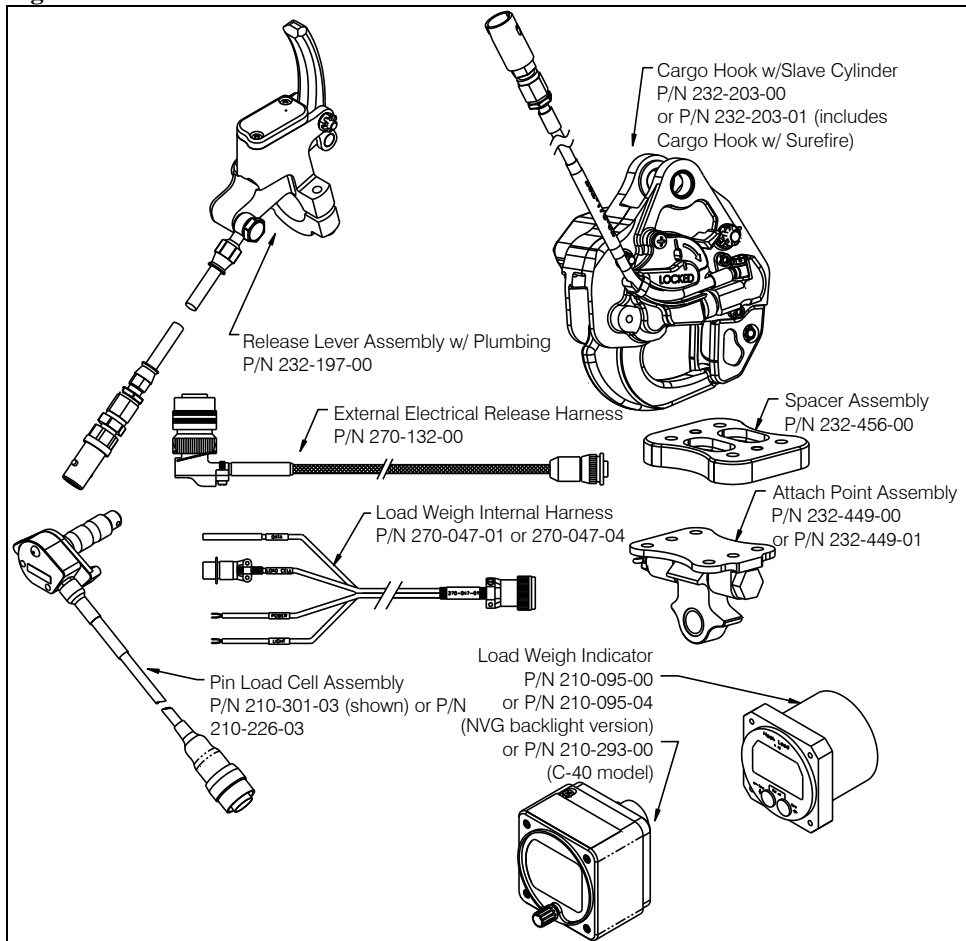

Figure 25.2.2 Kit Overview – P/N 200-379 Series



25.5 Component Weights

The weights and cgs of the systems are listed in Table 25.5.1.

Table 25.5.1 Component Weights and CGs

Item	Weight	Station
Kit P/N 200-378-XX		
Removable Provisions*	3.5 lbs (1.9 kgs)	99
Fixed Provisions**	2.4 lbs (1.10 kgs)	63
Total	5.9 lbs (2.68 kgs)	84.4
Kit P/N 200-379-XX		
Removable Provisions*	4.20 lbs (1.90 kgs)	99
Fixed Provisions**	3.01 lbs (1.36 kgs)	64
Total	7.21 lbs (3.26 kgs)	84.4

* The removable provisions include the cargo hook, external hydraulic release, load cell and external electrical release cable. These items are easily removed if they are not needed on the helicopter's mission. Refer to Section 25.16 for removal instructions.

** The fixed provisions are those items of the kit that remain on the aircraft. These include the fixed hydraulic release system, internal electrical load weigh harness, load weigh indicator, and attach point assembly. These components would typically be left on the aircraft when configuring the aircraft for non-external load work.

25.12 Storage Instructions

For temporary storage the master cylinder must be stored with the reservoir lid up. The lid contains an air vent that will allow hydraulic fluid to drain out if left inverted. If long term storage or shipping must be done where the orientation of the master cylinder cannot be controlled, either drain the reservoir or place a piece of tape or similar over the air vent to prevent leakage. If draining before storage, remove the hose attached to the master cylinder and drain it as well. Seal the hydraulic parts in a plastic bag for shipping or storage to prevent dirt contamination. The slave cylinder end needs no special handling. It is recommended that the cables be removed from the swing frame for shipping to reduce the possibility of the cables being kinked.

Clean the exterior Cargo Hook and Load Cell components thoroughly of excess dirt and grease with a rag before packaging. Refer to CMM 122-015-00 for storage instructions for the Cargo Hook. Refer to MIL-PRF-23199 and MIL-STD-2073-1 for additional guidance.

Package the unit in a suitable fiberboard box and cushion the unit to prevent shifting. Seal the fiberboard box with tape and mark the box with the contents and date of packaging.

25.15 Troubleshooting

Table 25.15.1 is provided with the intention of isolating the cause of malfunctions within the system. Sections 25.16 and 25.17 include instructions for removing and replacing defective components. Refer to the appropriate MD Helicopter maintenance instructions for guidance on procedures relating to parts that interface with these kits.

Table 25.15.1 Troubleshooting

MALFUNCTION	PROBABLE CAUSE	CORRECTIVE ACTION
Cargo hook does not operate electrically or manually.	Defective internal mechanism.	Remove and replace cargo hook (see sections 25.16 and 25.17) or repair per CMM 122-015-00.
Cargo hook P/N 528-028-00 does not operate electrically, manual hydraulic release operates normally.	Open electrical circuit, faulty wiring, fuse, switch or solenoid.	Disconnect cable from electrical connector on cargo hook. Using multi-meter, check for 3.0 to 4.0 ohms between pins A and B of electrical connector (see note 1 below). If open indication is obtained, remove and replace cargo hook (see sections 25.16 and 25.17) or repair per CMM 122-015-00.
Cargo hook P/N 528-028-02 (includes Surefire time delay circuit) does not operate electrically, hydraulic release operates normally.	Release switch not held down long enough. Open electrical circuit, faulty wiring, circuit breaker, switch or solenoid.	Hold the release switch for a longer time. The time delay circuit incorporates an electronic delay of approximately ½ second after which time the hook solenoid will activate repeatedly. If the release switch is not held down long enough the cargo hook's solenoid will not activate. Check the aircraft circuit for opens and shorts by using a multi-meter on the hook connector. When the release switch is pressed 28V aircraft voltage should be present on the connector pins. Check the aircraft connector polarity. The time delay circuit is polarity sensitive and protected against reverse polarity. +28V should be on pin B and ground on pin A. Check the power pins on the hook itself. A multi-meter set to the kilo-ohms range should read between 2-8 Kohms. Some auto-ranging meters will not read properly so be sure to try a manual kilo-ohms range. If the meter reads open or short there is a problem with the solenoid module itself and the hook should be replaced or repaired per CMM 122-015-00.
Cargo hook operates electrically, but not manually.	Leaks in hydraulic hose system. Air in hydraulic hose system. Jammed slave cylinder.	Check for leaks in hydraulic hose system and correct defects if found. Bleed hydraulic system per this manual. Remove slave cylinder from cargo hook and check for proper operation while actuating manual release lever. Repair cargo hook per CMM 122-015-00.

Table 25.15.1 Troubleshooting continued

MALFUNCTION	PROBABLE CAUSE	CORRECTIVE ACTION
Load beam fails to re-latch after being reset.	Defective latch mechanism.	Remove and replace cargo hook (see sections 25.16 and 25.17).
Force required to release hook with lever on collective exceeds 14 lbs.	Friction in internal mechanism or defective hydraulic system.	Remove slave cylinder from hook and manually operate master cylinder. If operation feels free and force is less than 5 lbs. Remove and replace cargo hook (see Section 25.16 and 25.17) or repair per CMM 122-015-00.
Hydraulic fluid leaks at hose fittings.	Loose fittings.	Tighten fittings. Check fluid level in reservoir. Bleed hydraulic system per Section 12.2.
Hydraulic fluid leaks around master or slave cylinder pistons.	Leaking seals	Replace master or slave cylinder assembly.
Cargo hook fails to open or re-lock properly.	Failure to open or re-lock properly.	Remove and replace cargo hook (see Sections 25.16 and 25.17) or repair per CMM 122-015-00.
Circuit breaker opens when cargo hook is energized.	Short in the system, faulty wiring, circuit breaker or solenoid.	Refer to MDHI maintenance documentation for internal cargo hook electrical release wiring. Check for shorts to ground along length of external wire harness (see note 2). Check solenoid resistance (see note 1), repair or replace defective parts.
Load Weigh Indicator does not power up.	Faulty wiring or circuit breaker.	Check the circuit breaker and wiring (see Note 2). If this doesn't help, remove and replace indicator per sections 25.16 and 25.17.
The displayed load on the Load Weigh Indicator is incorrect.	Incorrect calibration code.	Ensure the correct calibration code has been entered (see Note 3).
C-39 model indicator only: Displayed load is not stable.	Dampening level is too low.	Adjust the dampening level to a higher number (see Note 4).
C-39 model indicator only: Indicator displayed load takes too long to change the reading when the load is changed.	Dampening level is too high.	Adjust the dampening level to a lower number (see Note 4).
Indicator does not change with changing hook loads.	Defective load cell, indicator failure or damaged wire harness.	Check for damaged wire harness (see note 2), remove and replace wire harness assembly or load cell (see sections 25.16 and 25.17).

Table 25.3 Notes:

1. Checking resistance at pins A and B.

Check for 3.0 to 4.0 ohms between pins A and B of electrical connector located on the cargo hook (see below).

Figure 25.15.1 Cargo Hook Electrical Connector

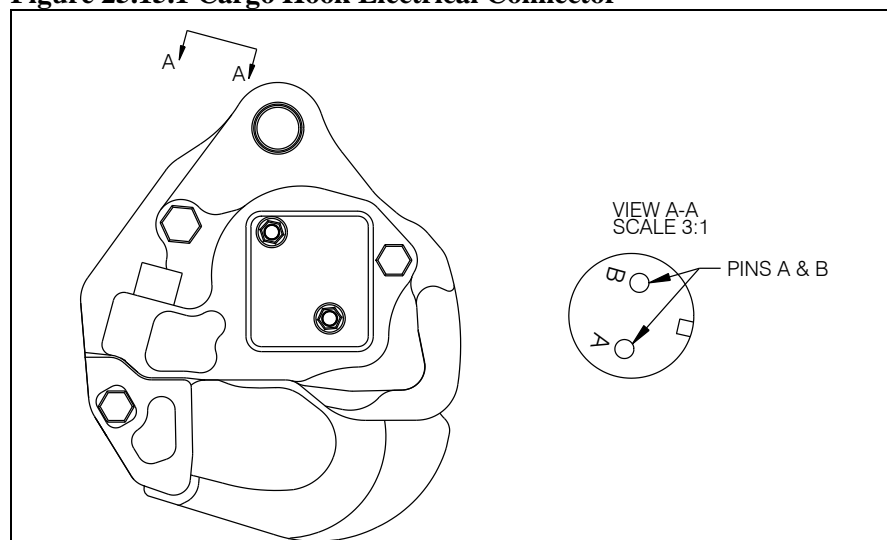

2. Checking Wire Harnesses.

As appropriate, before working on a circuit, e.g. - inspection, removal-installation of components, make sure that the BAT-OFF-EXT switch is off.

The external wire harnesses are located as shown below. The electrical release harness from the cargo hook is terminated at the connector located in the doubler in the aircraft belly skin (see below) and interfaces with the existing MD Helicopter cargo hook electrical wiring (refer to MD maintenance manuals for information).

The load cell (if installed) harness is routed with the electrical release harness and is terminated at the connector in the belly skin located approximately as shown below. The load weigh internal harness is routed from the connector shown in the figure below to the load indicator, which has an optional mounting location within the cockpit.

Inspect for general condition and chafing along length of wire runs. See Figure 25.15.3 for electrical schematic.

Table 25.3 Notes continued:

2. Checking Wire Harnesses continued

Figure 25.15.2 Wire Harness Routing

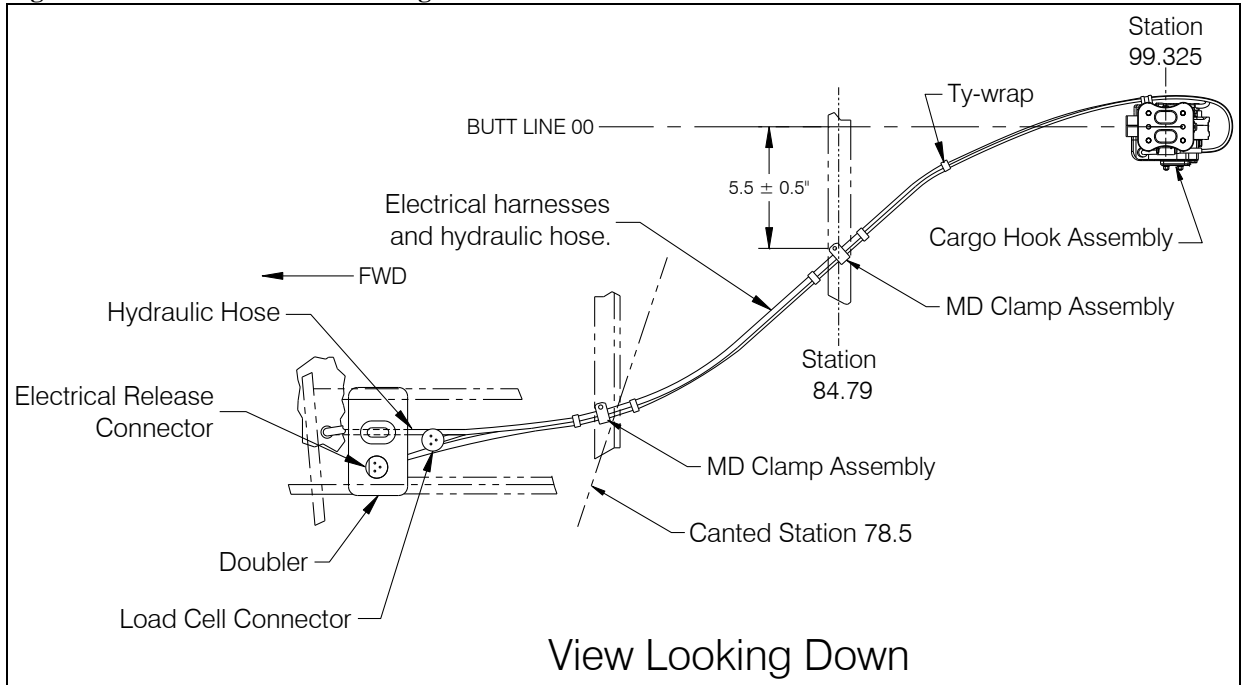

Figure 25.15.3 Electrical Schematic

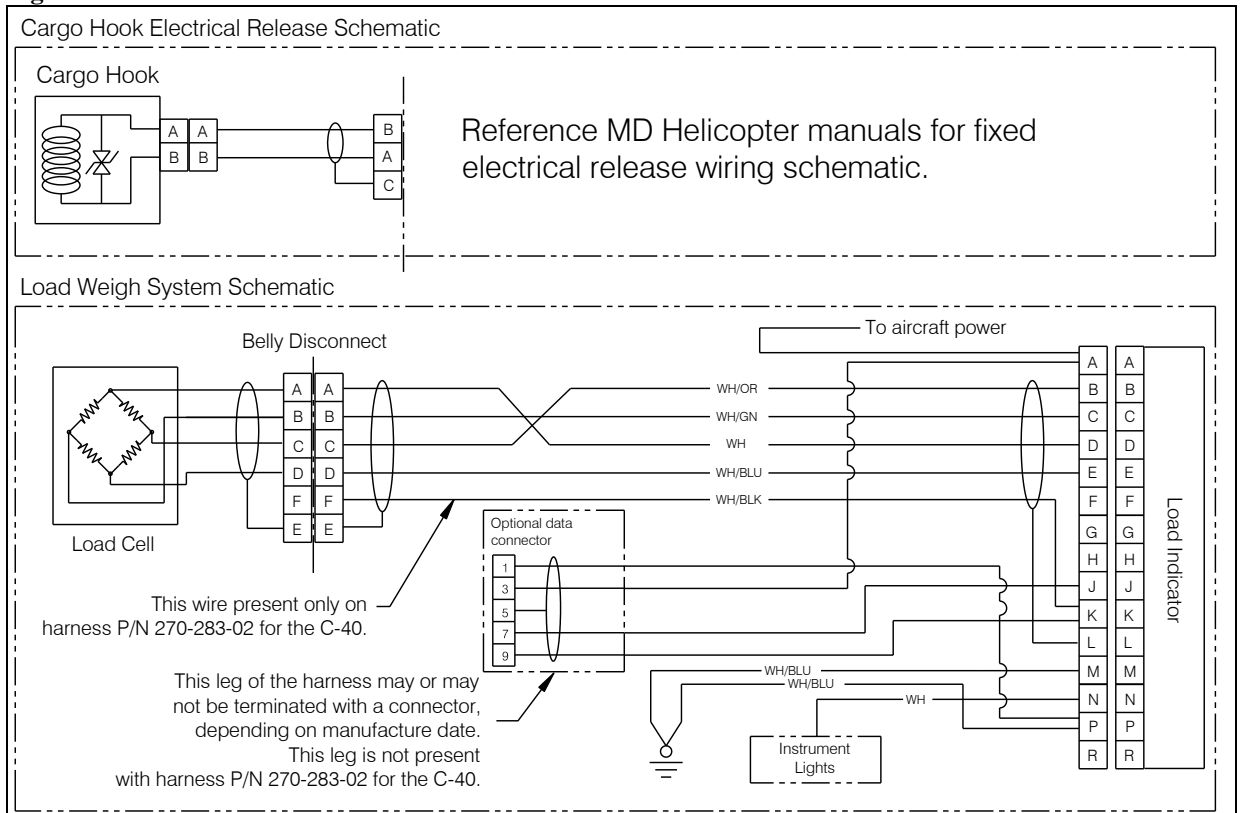
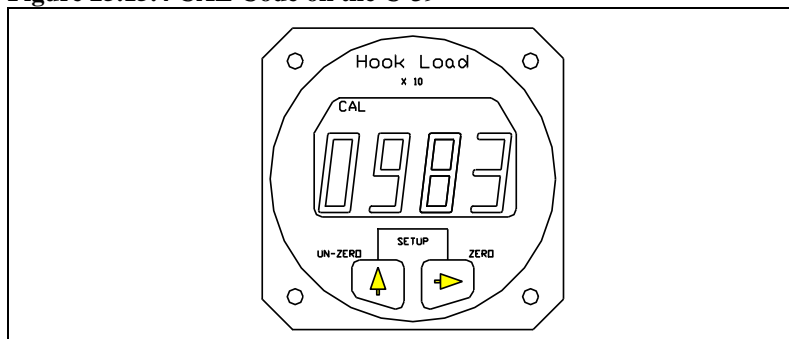

Table 25.3 Notes continued:

3. Checking the calibration code on the C-39 model indicator:

With the Indicator powered up and in the Run Mode, press both buttons at the same time to go to Setup. Scroll through the menu until the word CODE is displayed, then press the Right button. The display should look like this:

Figure 25.15.4 CAL Code on the C-39



This code should match the code printed on the tag attached to the load cell cable. If this code does not match, contact Onboard Systems for further guidance.

For the C-40 model indicator:

Enter the C-40 Settings menu: from the Load screen rotate the knob and the Settings introduction screen will appear (shown below).

Figure 25.15.5 C-40 Settings Screen



Press the knob again to enter the Settings menu. To scroll through the Settings menu, rotate the knob right to advance to "Cal Code" and press the knob to view or change this setting.

To change the calibration code, rotate the knob to the left to decrease the value or to the right to increase the value. If changing the value by a significant amount, spinning the knob rapidly will increase the rate of change.

Press to select when the correct value is displayed and press and hold the knob to exit the Settings menu. Refer to the Owner's Manual (manual no. 120-152-00) for the C-40 Indicator for additional information on settings.

Table 25.3 Notes continued:

4. **Adjusting dampening level on the C-39 model indicator:**

The C-40 Indicator is designed to provide a stable display thus does not include a dampening function.

On the C-39 with the unit powered up and in the Run Mode, press both buttons at the same time to go to Setup. Scroll through the menu, using the Left button, until the word DAMP is displayed. To look at or change the Dampening Level press the Right button. The display should look like this:

Figure 25.15.6 Changing Dampening Level

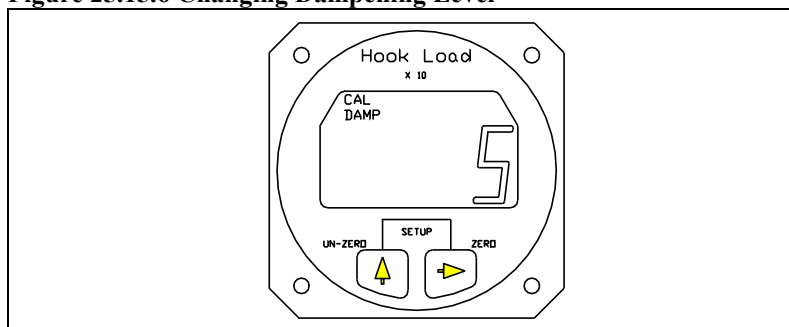

The CAL and the DAMP legend is turned on and the previously set dampening level is displayed. To return to Run without changing the current dampening level press both the Right and Left buttons at the same time. To change the dampening number, use the Left button to scroll the blinking digit to the desired number. Ten dampening levels are available, from 0 through 9. At level 0 the display responds to the slightest change in weight. However, if the load bounced even slightly, the display digits would respond instantly, making the display look unstable. With a dampening level of 9, the display would be stable under the most turbulent conditions, however, it would take several seconds for the display to respond to a change in weight. The ideal dampening level will depend on the flying conditions. A mid range setting of 5 or 6 is usually adequate. After the selection has been made press both the Right and Left buttons at the same time to return to Run.

25.16 Component Removal

Cargo Hook Removal

1. Cut and remove safety-wire at the slave cylinder assembly.
2. Remove the slave cylinder assembly by removing two screws (refer to Figure 25.16.2) and associated ty-raps.
3. Disconnect the electrical release harness connector at the Cargo Hook.
4. Remove the cotter pin (P/N 510-178-00) from the Attach Bolt (P/N 290-332-00) or Pin Load Cell (P/N 210-226-03 or P/N 210-301-03) if load weigh system is installed (refer to Figure 25.17.3 and Figure 25.17.4).
5. Remove the castellated nut (P/N 510-170-00) from the Attach Bolt (or Pin Load Cell)
6. Remove Attach Bolt (or Pin Load Cell) and all washers.
7. Remove the Cargo Hook.

Attach Point Assembly Removal

1. Remove cargo hook per the above instructions.
2. Cut safety-wire and remove the four bolts that secure the Attach Point Assembly and Spacer Assembly to the belly of the helicopter and the loop clamp (not shown) at the forward right bolt.

Figure 25.16.1 Attach Point Assembly Removal

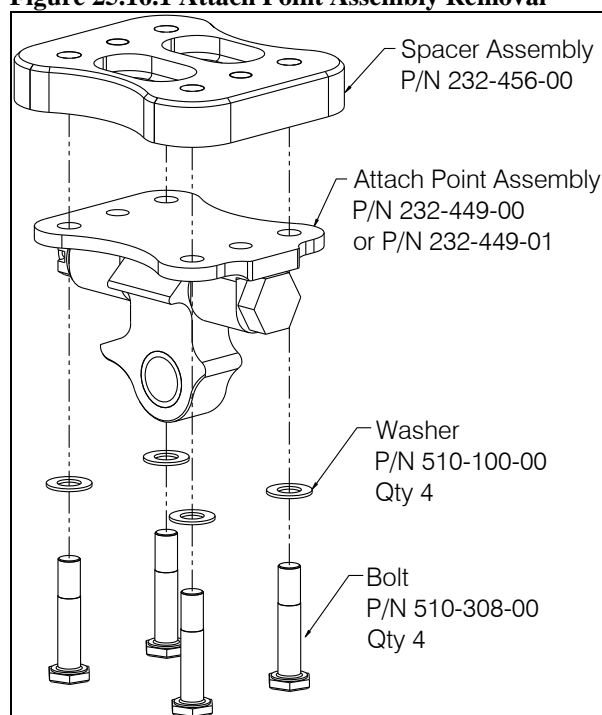

25.16 Component Removal continued

Slave Cylinder and Plumbing Assembly Removal

1. Disconnect the hose at the quick disconnect coupling beneath the pilot's seat and remove the hose from its supporting brackets along the belly of the helicopter.
2. Cut the safety wire and remove the two screws that hold the slave cylinder assembly to the cargo hook. Remove the ty-rap that secures the hydraulic hose to the manual release cover of the cargo hook.

Figure 25.16.2 Slave Cylinder Assembly Removal

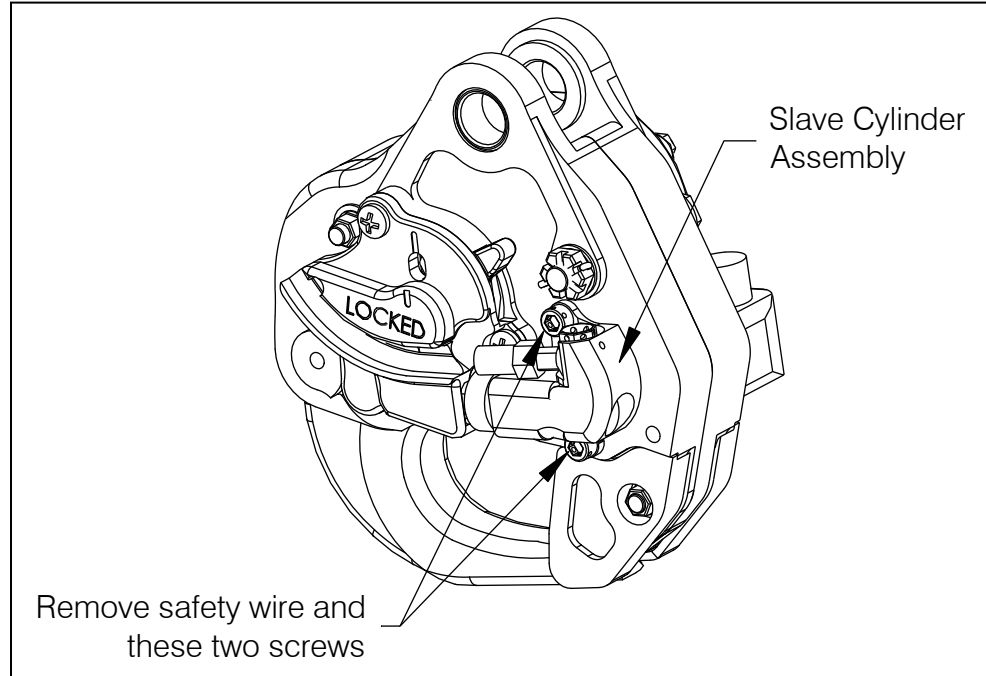

25.16 Component Removal continued

Fixed Hydraulic Release Plumbing Assembly Removal

The fixed hydraulic release hose is routed from the master cylinder release lever mounted to the pilot's cyclic tube to underneath the cabin floor where it is mated via a quick disconnect coupling with the slave cylinder plumbing from the cargo hook.

Figure 25.16.3 Master Cylinder and Plumbing Installation Overview

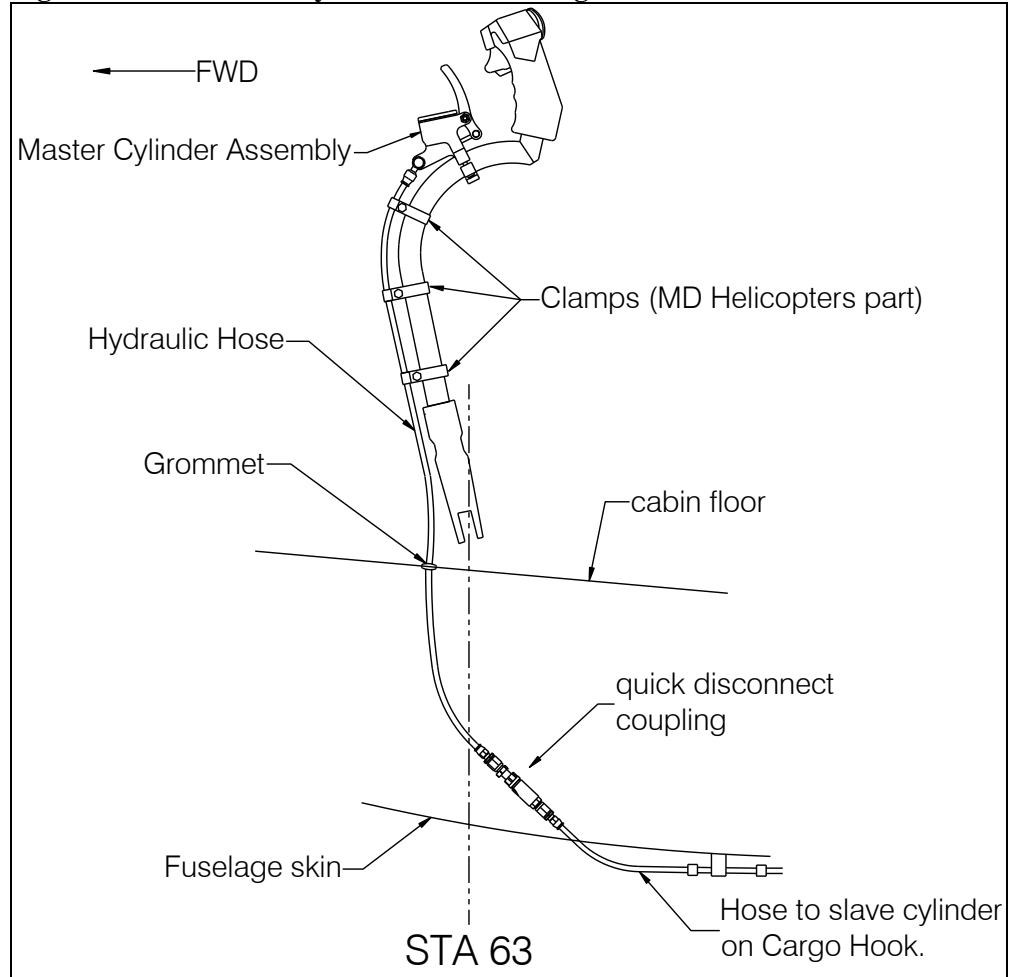

25.16 Component Removal continued

Fixed Hydraulic Release Hose Assembly Removal continued

1. Disconnect the master cylinder plumbing from the slave cylinder plumbing by separating the quick disconnect coupling located under the seat.
2. Remove the hose from the three clamps on the pilot cyclic stick.
Note: These clamps are part of the original equipment installation that these kits are a replacement for. Refer to MD maintenance manuals for part numbers.
3. Remove the grommet (P/N 505-016-00) from the hole in the cabin floor.
4. Pull the hose up through the hole in the floor.
5. Remove the master cylinder from the pilot's cyclic stick by removing two screws (see below).

Figure 25.16.4 Master Cylinder Removal

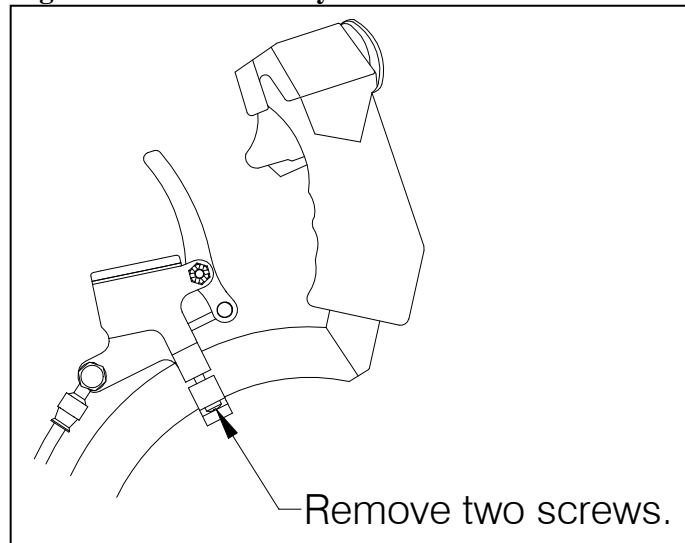

25.16 Component Removal continued

Load Weigh Indicator Removal

The load weigh indicator (included with kit P/Ns 200-379-00, 200-379-01, 200-379-10 and 200-379-11 only) location is optional within the cockpit.

1. Remove the four screws that secure the indicator in its position and remove the indicator.
2. Disconnect electrical connector from the back of indicator.

Pin Load Cell Removal

The Pin Load Cell also serves as the cargo hook attach bolt when the load weigh system is present.

1. Disconnect the electrical connector at the belly of the helicopter.
2. Remove electrical harness from cushioned loop clamps along the belly of the helicopter and remove the spiral wrap near the cargo hook.
3. Remove the cotter pin and nut from the end of the load cell and remove the Pin Load Cell from the cargo hook.

25.17 Component Re-installation

Attach Point Assembly Re-installation

1. Install the Attach Point components to the belly of the helicopter using the hardware supplied, as illustrated below, leaving the forward right bolt and washer out until the electrical harnesses and hose can be routed through a cushioned loop clamp to be installed here.
2. Torque the three bolts to 50-80 in-lbs.

Figure 25.17.1 Attach Point Assembly Re-installation

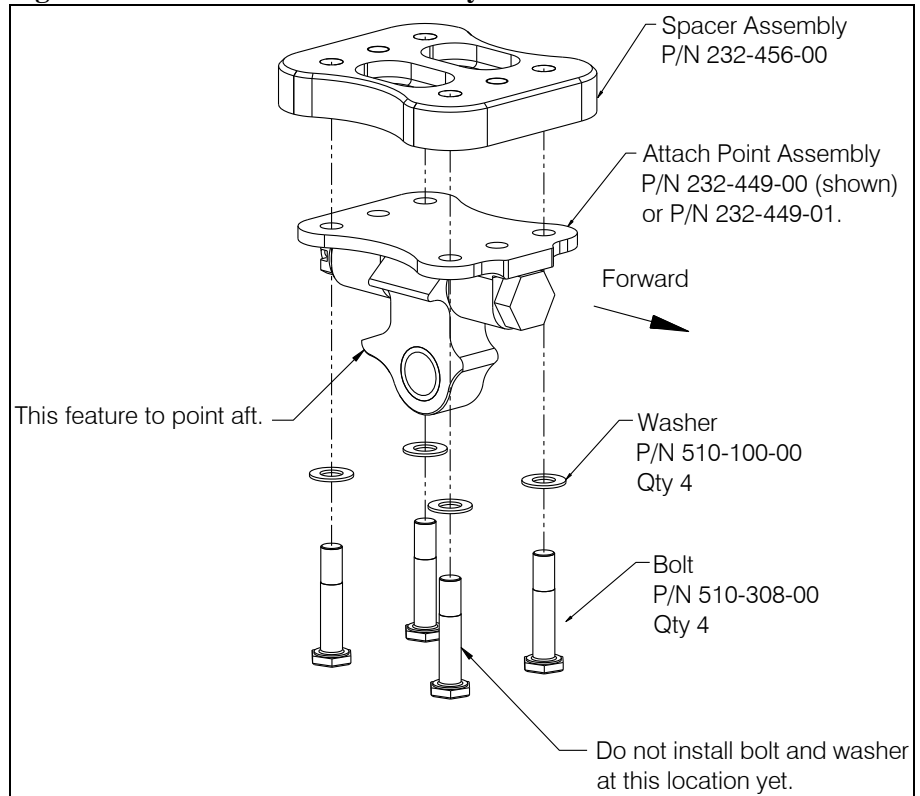

25.17 Component Re-installation continued

Cargo Hook Re-installation

1. Assemble slave cylinder with plumbing assembly (P/N 232-200-00) onto Cargo Hook (P/N 528-028-00 or P/N 528-028-02) per the instructions in this section.
2. Connect electrical release harness connector onto mating Cargo Hook connector.
3. Attach the Cargo Hook to the attach point assembly with the Attach Bolt (P/N 290-332-00) and washer (P/N 510-183-00) or pin load cell assembly (P/N 210-226-03 or P/N 210-301-03) if load weigh system is installed.



The Cargo Hook must be oriented as shown. The attach point assembly is “keyed” thus if the cargo hook cannot be installed in the orientation shown below the attach point assembly must be reversed.

Figure 25.17.2 Cargo Hook Orientation

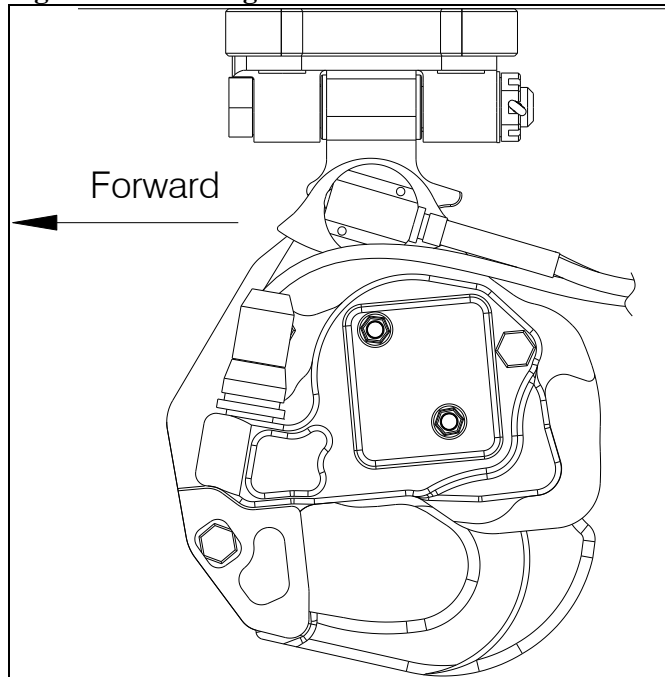

25.17 Component Re-installation continued

Cargo Hook Re-installation continued

4. Install washer (P/N 510-183-00), washer (P/N 510-174-00) and nut (510-170-00) over Attach Bolt end (or Pin Load Cell).
5. Tighten nut on attach bolt or Pin Load Cell until fully seated, finger tight only. Back off nut to previous castellation, if needed, when aligning cotter pin for installation. Install and secure cotter pin (P/N 510-178-00).

CAUTION

Do not tighten nut on pin load cell more than finger tight. Over-tightening will damage load cell.

6. Route electrical harnesses and hydraulic hose per Figure 25.17.6.

Figure 25.17.3 Cargo Hook Attachment Hardware

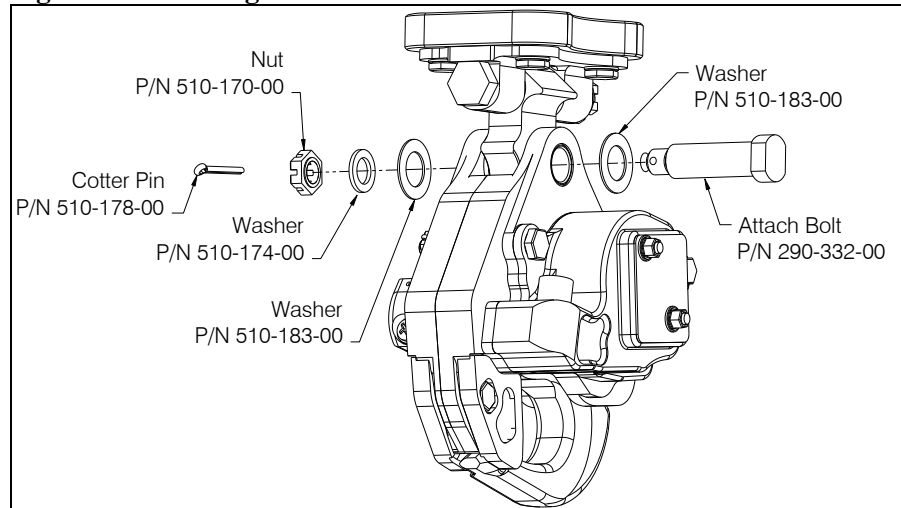
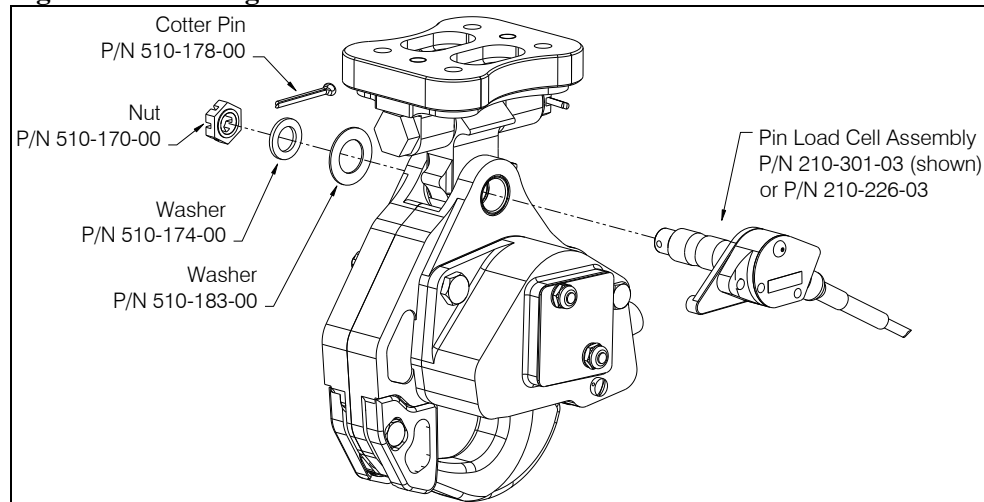

Figure 25.17.4 Cargo Hook Attachment w/ Pin Load Cell



25.17 Component Re-installation continued

Slave Cylinder Assembly Re-installation

Connect the slave cylinder assembly (P/N 232-200-00) to the cargo hook first, per the following instructions:

1. Ensure that the piston is in the retracted position. If the piston needs to be retracted connect the quick disconnect coupling and push the piston in.

NOTICE

The piston will not be able to be retracted if the hydraulic hose is not connected at the quick disconnect.

2. Insert the nose of the slave cylinder assembly into the side of the cargo hook as shown (ref Figure 25.17.5) and install the mounting screws (P/N 510-531-00). Torque screws to 12-15 in-lbs.
3. Install safety wire between these screws around the backside of the slave cylinder.
4. Route the hydraulic hose along the manual release cover and secure with a ty-rap through the hole at the end of the groove in the manual release cover.

Figure 25.17.5 Slave Cylinder Assembly Installation

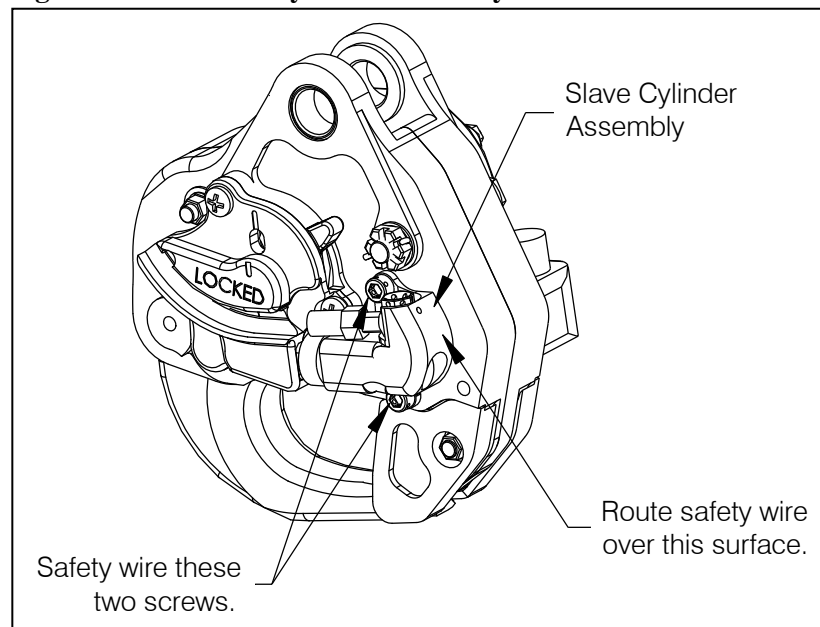

25.17 Component Re-installation continued

External Electrical Harness and Hose Routing

NOTICE

The instructions below reflect an installation with a load cell. These instructions are also applicable to an installation without load cell.

1. Route the electrical harnesses and hydraulic hose as shown in Figure 25.17.6. Before tightening loop clamp, ensure that there is sufficient slack in the harness and hose bundle to allow for full movement of the cargo hook.
2. Re-install spiral wrap (P/N 590-013-00) over harnesses and hose.
3. Route the bundle forward through the two MD Clamp Assemblies (as shown in Figure 25.17.7).

Figure 25.17.6 Hydraulic Hose and Electrical Harness Routing

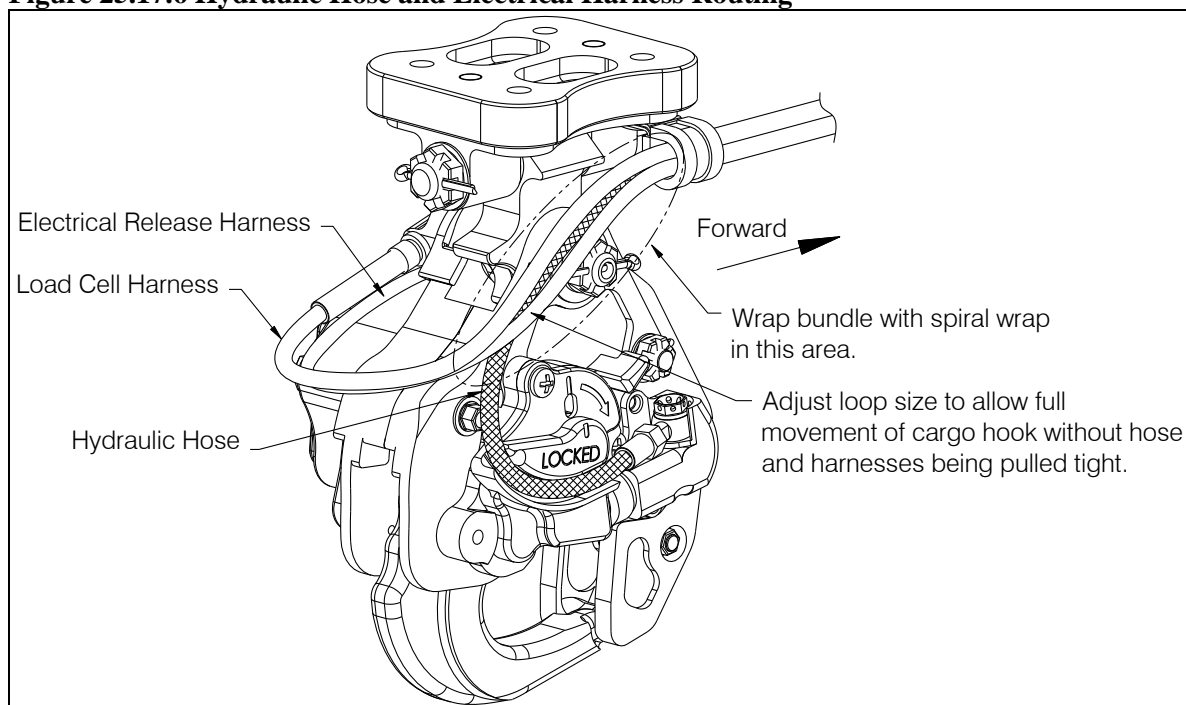

25.17 Component Re-installation continued

External Electrical Harness and Hose Routing continued

4. Connect the electrical connectors to the fixed connector at the doubler.
5. Slide the grommet over the end of the hose. Insert the quick disconnect end of the hydraulic hose through the slot at the doubler at the aircraft skin to mate up with the plumbing from the master cylinder and re-install grommet in the slot.

Figure 25.17.7 External Hose and Harness Routing

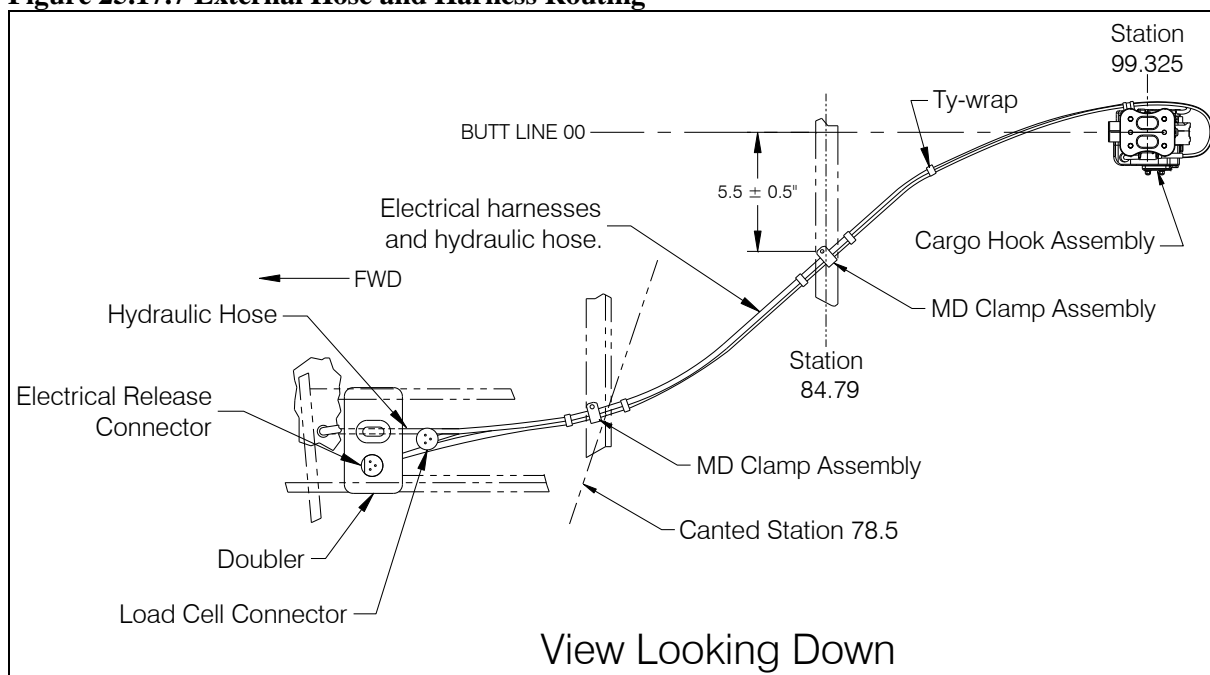

25.17 Component Re-installation continued

Fixed Hydraulic Release Hose Re-installation

1. Install the master cylinder and release lever onto the cyclic with the two screws (P/N 510-390-00). Tighten screws until master cylinder is clamped securely on the cyclic but do not over-tighten which could possibly dent cyclic tube.
2. Attach the hose to the three clamps on the pilot's cyclic tube (see Figure 25.16.3).
3. Feed the quick disconnect fitting at the end of the hydraulic hose through the hole in the floor. Re-install the grommet.
4. Underneath the floor connect the quick disconnect coupling to the mating fitting on the slave cylinder hose.
5. After completing installation of the hydraulic system (both fixed and removable) bleed the system per section 12.2. If the hoses have not been disassembled, the system may not need to be bled. Check function per Section 5.1.
6. If desired, adjust the position of the lever (see below) on master cylinder. Secure lever adjustment screw with set screw. Ensure there is no interference in any combination of lever movements.

Figure 25.17.8 Lever Adjustment

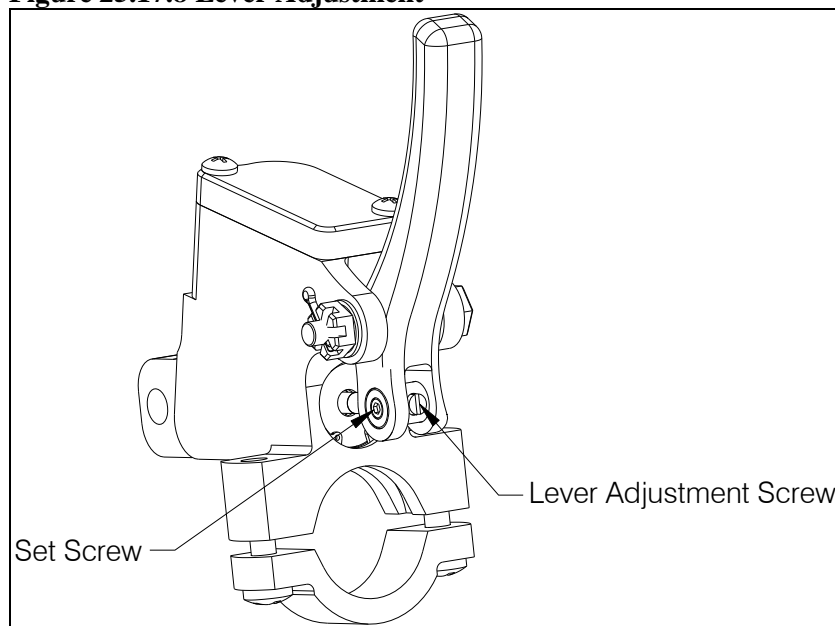

Load Weigh Indicator Re-installation

1. Place the Load Weigh Indicator into the mounting location and secure with four screws. Tighten screws to 12-15 in-lbs.
2. Connect the electrical connector on the wiring harness to the connector on the back of the indicator.

25.18 General Procedural Instructions-Testing

After re-installation of the cargo hook, hydraulic release system components, or electrical harness, perform the following:

1. Activate the electrical system and press the Cargo Hook release button to ensure the cargo hook electrical release is operating correctly. The Cargo Hook must release. Reset the hook by hand after the release. If the hook does not release or re-latch, do not use the unit until the difficulty is resolved.



The cargo hook solenoid is intended to be energized only intermittently. Depressing the electrical release button continuously in excess of 20 seconds will cause the solenoid to overheat, possibly causing permanent damage.

The following instructions are applicable to cargo hook P/N 528-028-02 which is equipped with Surefire electrical release. With no load on the cargo hook perform the following.

- Very briefly press the Cargo Release switch, the cargo hook should not actuate and the load beam should remain closed.
 - Press and hold the Cargo Release switch for a few seconds, the load beam should fall to the open position and the cargo hook solenoid should continue to cycle repeatedly.
 - Push up on the load beam and verify that it latches and the hook lock indicator is aligned with the engraved line on the manual release cover.
2. Activate the hydraulic release system by pulling the release lever on the cyclic in the cockpit. The mechanism should operate smoothly and the cargo hook must release. Return the load beam to its closed and locked position by hand after release. Verify that the hook lock indicator on the side of the hook returns to the fully locked position. In the fully locked position the hook lock indicator should align with the white lines (see Figure 5.1.1). If the hook does not release or re-latch, do not use the unit until the problem is resolved.
 3. Swing the installed Cargo Hook to ensure that the hydraulic hose and the electrical harnesses have enough slack to allow full movement without straining or damaging the hose or harnesses. The hose and harnesses must not be the stops that prevent the Cargo Hook from swinging freely in all directions.