

**PLEASE CHECK WEB SITE AT WWW.ONBOARDSYSTEMS.COM FOR
THE LATEST REVISION OF THIS MANUAL**

**Instructions for
Continued Airworthiness
Cargo Hook
Suspension Systems
For the
Robinson R44 Series**

STC SR01808SE

Part Numbers

**200-324-00, 200-325-00, 200-325-01, 200-326-00,
200-327-00, 200-327-01, 200-327-02, 200-327-10, 200-327-11, 200-327-12 and 200-396-00**



13915 NW 3rd Court Vancouver, Washington 98685 USA
Phone: 360-546-3072 Fax: 360-546-3073 Toll Free: 800-275-0883
www.OnboardSystems.com

THIS PAGE INTENTIONALLY LEFT BLANK

Record of Revisions

<i>Revision</i>	<i>Date</i>	<i>Page(s)</i>	<i>Reason for Revision</i>
5	11/12/13	00-00-00 Page 2, Section 5, 25-00-00 Page 15	Updated Distribution of Instructions for Continued Airworthiness section. Updated installation of pin load cell. Updated external load operation definition. Moved items from daily check to annual inspection and removed daily check section.
6	02/13/14	25-00-00 Page 7, 13 & 14	Added bolt P/N 511-076-00 as an alternate to P/N 290-505-00.
7	06/16/15	Section 5 pages 5, 6, 8, 9, Section 25 pages 3, 7, 15	Added load cell P/N 210-301-01, listed load cell in parts requiring NDT, updated storage instructions section to refer to cargo hook CMM for cargo hook storage.
8	10/09/15	Section 5 page 1, 4, 7 Section 11, Section 25 pages 2-4, 6, 11, 12, 17- 20	Added remote hook electrical release kit P/N 200-396-00 and associated maintenance instructions. Updated trouble shooting table, clarified suspension disassembly.
9	07/29/16	Section 25 page 4, 6, 10, 17, 18, 19	Added external connector assembly P/N 270-230-01, clarified release switch removal and re-installation instructions, added references to CMM 122-017-00 in troubleshooting table.
10	03/28/17	Section 1 page 1 Section 5 page 1, 2 Section 11 Section 25 pages 1, 2, 2 – 5, 20	Added kit P/N's 200-327-10 and 200-327-11 which include cargo hook P/N 528-029-02 with Surefire release. Added associated instructions.
11	03/08/18	Section 5 Page 8	Removed magnetic particle inspection requirement.
12	03/12/20	Section 5, Section 11, Section 25 pages 2 – 5, 12, & 19	Added C-40 load indicator and associated kit P/Ns and instructions. Re-organized section 5.0.

THIS PAGE INTENTIONALLY LEFT BLANK

List of Effective Pages

Title	Pages	Revision	Date
Cover	i, ii Blank	12	03/12/20
Record of Revisions	iii, iv Blank	12	03/12/20
List of Effective Pages	v, vi Blank	12	03/12/20
Contents	vii, viii	12	03/12/20
Section 0 Introduction	1	12	03/12/20
Section 0 Introduction	2	5	11/12/13
Section 4 Airworthiness Limitations	1, 2 Blank	0	10/29/07
Section 5 Inspection and Overhaul Schedule	1 thru 11, 12 Blank	12	03/12/20
Section 11 Placards and Markings	1, 2	12	03/12/20
Section 25 Operation Instructions	1	0	10/29/07
Section 25 Operation Instructions	2 thru 5	12	03/12/20
Section 25 Operation Instructions	6	9	07/29/16
Section 25 Operation Instructions	7	7	06/16/15
Section 25 Operation Instructions	8	0	10/29/07
Section 25 Operation Instructions	9	1	02/03/09
Section 25 Operation Instructions	10	9	07/29/16
Section 25 Operation Instructions	11	8	10/09/15
Section 25 Operation Instructions	12	12	03/12/20
Section 25 Operation Instructions	13, 14	6	02/13/14
Section 25 Operation Instructions	15	7	06/16/15
Section 25 Operation Instructions	16	4	07/23/10
Section 25 Operation Instructions	17, 18	9	07/29/16
Section 25 Operation Instructions	19	12	03/12/20
Section 25 Operation Instructions	20	10	03/28/17

THIS PAGE INTENTIONALLY LEFT BLANK

CONTENTS

<u>Identification</u>	<u>Title, Page</u>
Section 0	Introduction 00-00-00
0.4	Scope, 1
0.5	Purpose, 1
0.6	Arrangement, 1
0.7	Applicability, 1
0.9	Abbreviations, 1
0.12	Precautions, 2
0.19	Distribution of Instructions for Continued Airworthiness, 2
Section 4	Airworthiness Limitations 04-00-00
Section 5	Inspection and Overhaul Schedule 05-00-00
5.1	Annual/100 Hour Inspection, 1
5.2	5 Year/1000 Hour Inspection, 5
5.3	Cargo Hook Overhaul Schedule, 11
Section 11	Placards and Markings 11-00-00
11.1	Placards, 1
Section 25	Equipment and Furnishings 25-00-00
25.1	Cargo Hook Connector, 1
25.2	Description, 2
25.5	Component Weights, 3
25.12	Storage Instructions, 3
25.15	Trouble Shooting, 4
25.16	Component Removal, 7
25.17	Component Re-installation, 13
25.18	General Procedures Instructions-Testing, 20

Figures

- 5.1.1 Hook Lock Indicator, Section 5 Page 2
- 5.1.2 Manual Release Cable Inspection, Section 5 Page 2
- 5.1.3 Manual Release Cable Conditions, Section 5 Page 3
- 5.1.4 Manual Release Cable Rigging, Section 5 Page 4
- 5.1.5 Cargo Hook Attachment Hardware, Section 5 Page 5
- 5.1.6 Cargo Hook Attach Hardware w/ Pin Load Cell, Section 5 Page 5
- 5.1.7 Suspension Assembly Parts, Section 5 Page 7
- 5.1.8 Suspension Assembly Identification, Section 5 Page 8
- 25.1 Un-commanded cargo hook release, Section 25 Page 1
- 25.2 Cargo Hook Electrical Connector, Section 25 Page 5
- 25.3 Electrical Schematic, Section 25, Page 6
- 25.4 Suspension Removal, Section 25, Page 7
- 25.5 Manual Release Cable, Section 25, Page 8
- 25.6 Manual Release Cable Exterior Routing, Section 25, Page 9
- 25.7 Release Switch, Section 25, Page 10
- 25.8 Left Seat Switch, Section 25, Page 11
- 25.9 Relay Location, Section 25, Page 12
- 25.10 Suspension Assembly Installation, Section 25, Page 14
- 25.11 Suspension Assembly Installation, Section 25, Page 14
- 25.12 Cargo Hook Attach Hardware, Section 25, Page 15
- 25.13 Cargo Hook Attach Hardware w/ Load Cell, Section 25 Page 15
- 25.14 Manual Release Cable Rigging, Section 25 Page 16
- 25.15 Release Switch Installation, Section 25 Page 17
- 25.16 Remote Hook Release Switch Location, Section 25 Page 18
- 25.17 Remote Hook Relay Locations, Section 25 Page 19

Tables

- 5.2.1 Cargo Hook Attachment Hardware Parts, Section 5 Page 6
- 5.2.2 Suspension System Parts, Section 5 Page 7
- 5.2.3 Suspension System Inspection, Section 5 Page 9
- 11.1 Cargo Hook Suspension System Placards, Section 11 Page 1
- 25.1 Cargo Hook Connector, Section 25 Page 1
- 25.2 System Weights and CGs, Section 25 Page 3
- 25.3 Trouble Shooting, Section 25 Page 4

Section 0

Introduction

0.4 Scope

The following information is necessary to carry out the service, maintenance, and inspection of an Onboard Systems International Cargo Hook Suspension System and optional Remote Hook Electrical Release Kit.

0.5 Purpose

The purpose of this Instructions for Continued Airworthiness (ICA) manual is to provide the information necessary to service, inspect and maintain the Cargo Hook Suspension Systems in an airworthy condition.

0.6 Arrangement

This manual contains instructions for the installation, maintenance inspection and operation of the Cargo Hook Suspension Systems on Robinson R44 and R44 II helicopters. The manual is arranged in the general order that maintenance personnel would use to maintain and operate the Cargo Hook Suspension System in service. The arrangement is:

- Section 0 Introduction.
- Section 4 Airworthiness Limitations (None apply to this System.)
- Section 5 Inspection and Overhaul Schedule
- Section 11 Placards and Markings
- Section 25 Equipment and Furnishings

0.7 Applicability

These Instructions for Continued Airworthiness are applicable to Cargo Hook Suspension System P/N's 200-324-00, 200-325-00, 200-325-01, 200-326-00, 200-327-00, 200-327-01, 200-327-02, 200-327-10, 200-327-11, and 200-327-12 and Remote Hook Electrical Release Kit P/N 200-396-00 on the Robinson R44 and R44 II helicopters.

0.9 Abbreviations

FAA Federal Aviation Administration
FAR Federal Aviation Regulation
ICA Instructions for Continued Airworthiness

0.12 Precautions

The following definitions apply to safety labels used in this manual.



Indicates a hazardous situation which, if not avoided, will result in death or serious injury.



Indicates a hazardous situation which, if not avoided, could result in death or serious injury.



Indicates a hazardous situation which, if not avoided, could result in minor or moderate injury.



Draws the reader's attention to important or unusual information not directly related to safety.



Used to address practices not related to personal injury.

0.19 Distribution of Instructions for Continued Airworthiness

Before performing maintenance ensure that the Instructions for Continued Airworthiness (ICA) in your possession is the most recent revision. Current revision levels of all manuals are posted on Onboard Systems Int'l web site at www.onboardsystems.com.

Onboard Systems offers a free notification service via fax or e-mail for product alerts and documentation updates. By registering Onboard Systems products on the web site, we will be able to contact you if a service bulletin is issued, or if the documentation is updated.

Notices can be chosen to be received on an immediate, weekly, or monthly schedule via fax, email or both methods. There is no charge for this service. Please visit the Onboard Systems web site at www.onboardsystems.com/notify.php to get started.

Section 4

Airworthiness Limitations

The Airworthiness Limitations section is FAA approved and specifies inspections and other maintenance required under Secs. 43.16 and 91.403 of the Federal Aviation Regulations unless an alternative program has been FAA approved.

No airworthiness limitations are associated with this type design change.

THIS PAGE INTENTIONALLY LEFT BLANK

Section 5

Inspection and Overhaul Schedule

The scheduled inspection intervals noted below are maximums and are not to be exceeded. If the cargo hook suspension system is subjected to unusual circumstances, extreme environmental conditions, etc., it is the responsibility of the operator to perform the inspections more frequently to ensure proper operation.

There is no maintenance to be performed on the Load Weigh Indicator (part of the optional load weigh system). Do not open the enclosure, if repair is needed return it to the factory.

5.1 Annual/100 Hour Inspection

Annually or 100 hours of external load operations (see section 5.3 for definition), whichever comes first, inspect the cargo hook and suspension per the following. Refer also to the Cargo Hook's Component Maintenance Manual 122-001-00 or 122-017-00 for additional criteria.

1. Activate the electrical system and press the Cargo Release button to ensure the cargo hook electrical release system is operating correctly. For the keepered cargo hook (P/N 528-010-04 or 528-010-06) approximately 10 lbs of downward force is required to open the cargo hook load beam and the load beam should automatically re-latch after release.

The keeperless cargo hook (P/N 528-029-00, 528-029-01, or 528-029-02) should open with no load on it and be closed by hand after release.



Depressing the electrical release button continuously in excess of 20 seconds will cause the cargo hook solenoid to overheat, possibly causing permanent damage.

The following instructions are applicable to cargo hook P/N 528-029-02 which is equipped with Surefire electrical release. With no load on the cargo hook perform the following.

- Very briefly press the Cargo Release switch, the cargo hook should not actuate and the load beam should remain closed.
- Press and hold the Cargo Release switch for a few seconds, the load beam should fall to the open position and the cargo hook solenoid should continue to cycle repeatedly.
- Push up on the load beam and verify that it latches and the hook lock indicator is aligned with the engraved line on the manual release cover (see Figure 5.1.1).

5.1 Annual/100 Hour Inspection *continued*

2. Activate the manual release system by pulling the T-handle in the cockpit. The cargo hook must release. For the keepered cargo hook the load beam must automatically re-latch. For the keeperless cargo hook reset the load beam by hand after release and verify that the lock indicator returns to the fully locked position (see Figure 5.1.1).



In the fully locked position the hook lock indicator must align with the lines on the manual release cover (see Figure 5.1.1).

Figure 5.1.1 Hook Lock Indicator

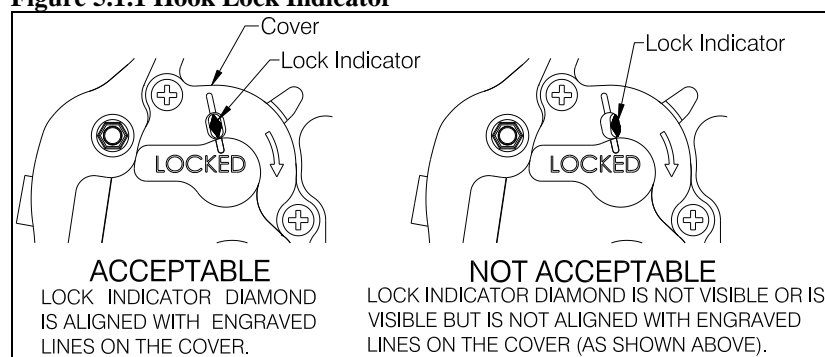

3. Move the cargo hook and the suspension system throughout their full ranges of motion and observe the manual release cable, electrical release harness and load cell harness (if installed) to ensure that they have enough slack. The cable and harnesses must not be the stops that prevent the cargo hook or suspension from moving freely in all directions.
4. Visually inspect the manual release cable for damage, paying close attention to the flexible conduit at the area of transition to the cargo hook end fitting (refer to Figure 5.1.2). Inspect for splitting of the outer conduit and separation of the conduit from the steel end fitting.

Figure 5.1.2 Manual Release Cable Inspection

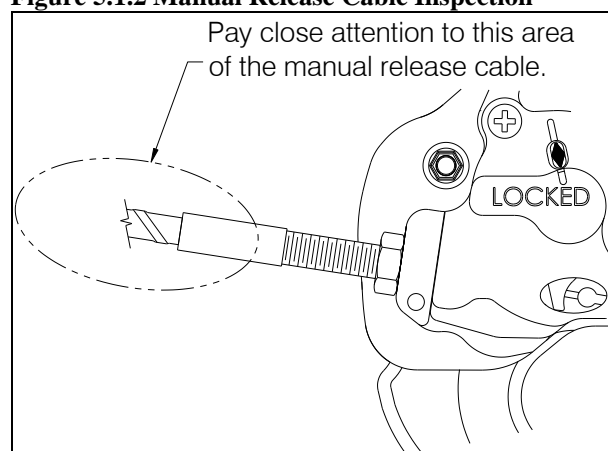

5.1 Annual/100 Hour Inspection continued

5. Remove the manual release cover from the cargo hook and inspect the visible section of the inner cable for kinks or frays.



Manual release cables are wearable items and must be replaced as condition requires. Broken or kinked conduit, inner cable kinks (ref Figure 5.1.3), frays, or sticky operation are each cause for immediate replacement.

Figure 5.1.3 Manual Release Cable Conditions

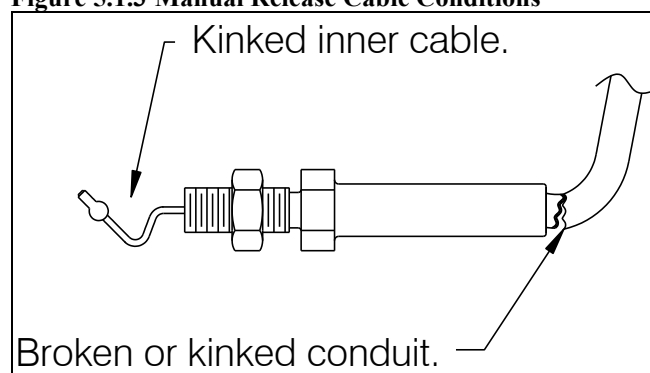

6. Check the manual release cable rigging per the following. With the cargo hook in the closed and locked position, rotate the release lever in the clockwise direction to remove free play (the free play is taken up when the hook lock indicator begins to move) and measure the gap between the cable ball end and the release lever fork with the manual release handle in the cockpit in the non-release position. There must be a minimum of .125 inches (3.2 mm) between the cable ball end and fork fitting as shown in Figure 5.1.4. The maximum amount of free play is limited by the manual release cover, i.e. – the ball end must fit inside the manual release cover when it is installed.

5.1 Annual/100 Hour Inspection continued

7. If necessary adjust the manual release cable system to obtain a minimum of .125 inches (3.2 mm). Some adjustment can be made at the cargo hook by loosening the jam nut and turning the manual release cable or cargo hook in the required direction and re-tightening the jam nut. Ensure the manual release cable fitting threads maintain full thread engagement with the cargo hook side plate boss (i.e.- the end of the threads should not be recessed within the boss). Tighten jam nut. Re-install the manual release cover with the two screws.

Figure 5.1.4 Manual Release Cable Rigging (P/N 528-029 series shown)

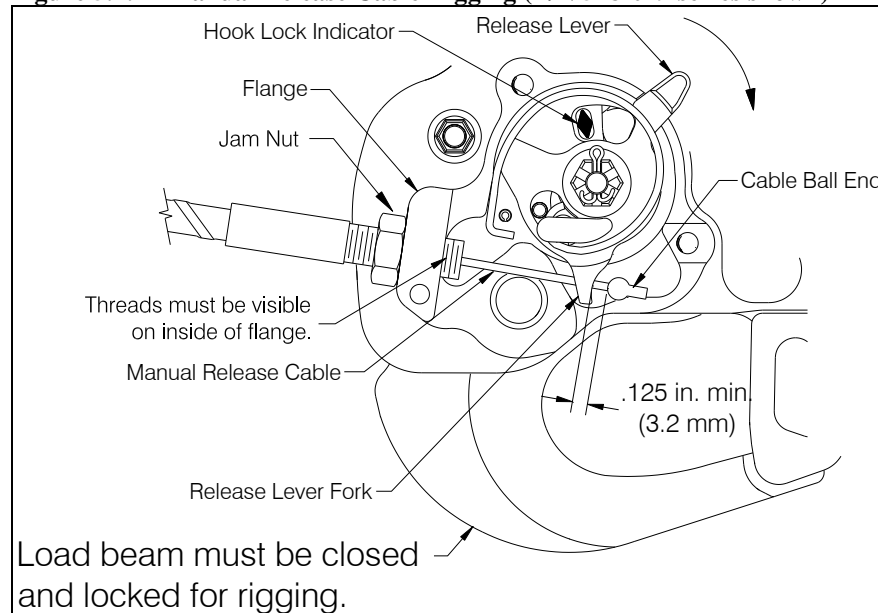

8. Visually inspect for presence and security of fasteners and electrical connections.
9. Visually inspect the external electrical wire harness for damage and security.
10. Visually inspect the manual release cable for damage and security, paying close attention to the area of transition from the steel fitting at the cargo hook to the flexible cable housing.
11. Visually inspect the suspension structural components for cracks and damage, paying close attention to the load link (item 7 in Figure 5.1.7).
12. Visually inspect the pin load cell strain relief and harness for damage and security (if load weigh system is installed).
13. In the cockpit visually inspect for security of the electrical release switches on the cyclic including the remote hook release switch if kit P/N 200-396-00 is installed.
14. Inspect for security of the C-39 or C-40 load weigh indicator (if the load weigh system option is installed).

5.2 5 year/1000 Hour Inspection

Every 1000 hours of external load operations or 5 years, whichever comes first, remove the suspension assembly from the helicopter, and disassemble per the following instructions and inspect. Refer to figures for part identification. Refer to section 5.3 for the overhaul schedule for the cargo hook.

1. Remove the cargo hook from the suspension assembly by removing cotter pin (item 5), nut (item 4), washers (items 2 and 3), and attach bolt (item 1). If the load weigh system is installed, the attach bolt (item 1) and one washer (item 2) are replaced by the pin load cell (item 6).

Figure 5.2.1 Cargo Hook Attachment Hardware

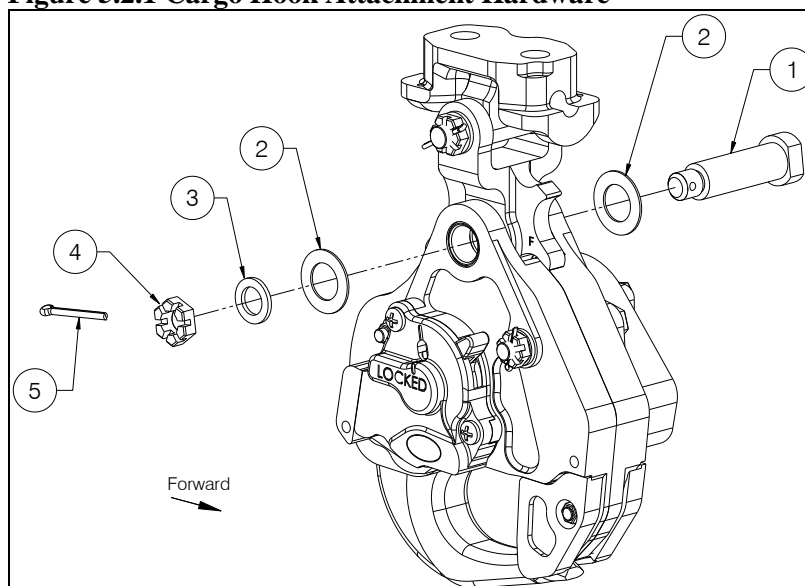
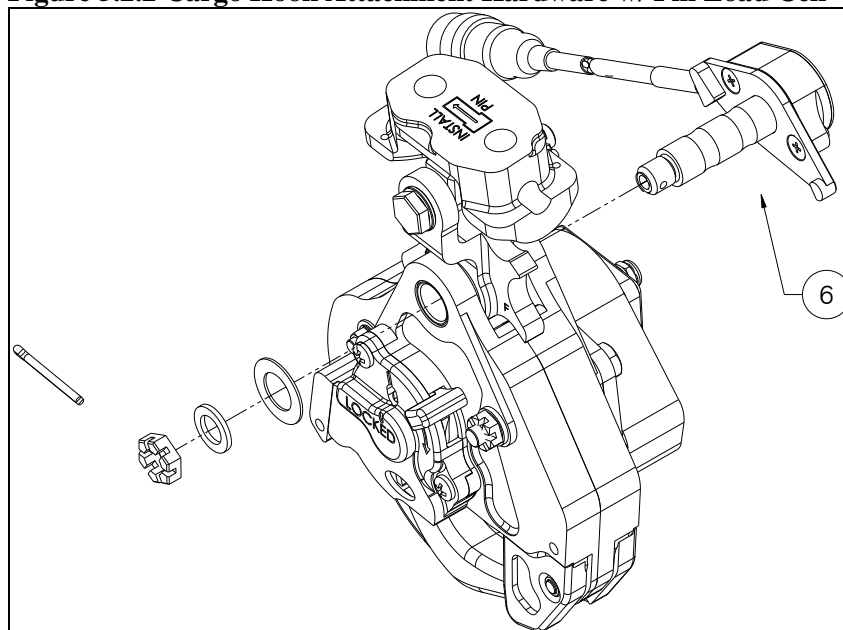

Figure 5.2.2 Cargo Hook Attachment Hardware w/ Pin Load Cell



5.2 5 year/1000 Hour Inspection continued

Table 5.2.1 Cargo Hook Attachment Hardware Parts

ITEM	PART NO.	DESCRIPTION	QTY
1*	290-332-00	Attach Bolt	1
2*	510-183-00	Washer	2
3	510-174-00	Washer	1
4	510-170-00	Nut	1
5	510-178-00	Cotter Pin	1
6	210-301-01**	Pin Load Cell	1

* If the load weigh system is installed, the Attach Bolt and (1) item 2 washer are replaced by the Pin Load Cell as shown.

** Supersedes P/N 210-226-01, these P/Ns are interchangeable in this installation.

5.2 5 year/1000 Hour Inspection continued

Disassemble the Suspension Assembly per the following (refer to Figure 5.2.3 for item nos.). Press out Bushings and Pin using an arbor press or similar.

1. Remove Link Assembly (items 6, 7, and 8) from the Gimbal Assembly (3 and 4) by removing cotter pin, nut and bolt (9, 10, and 11).
2. Remove the Gimbal Assembly from the Pillow Block (1) by removing the Pin (2). If P/N 291-108-01 Pillow Block (see Figure 5.1.8 for identification) is installed, the Pin must be pressed out. Press out in the opposite direction of the INSTALL PIN engraved arrow (see Figure 5.1.8).

Figure 5.2.3 Suspension Assembly Parts

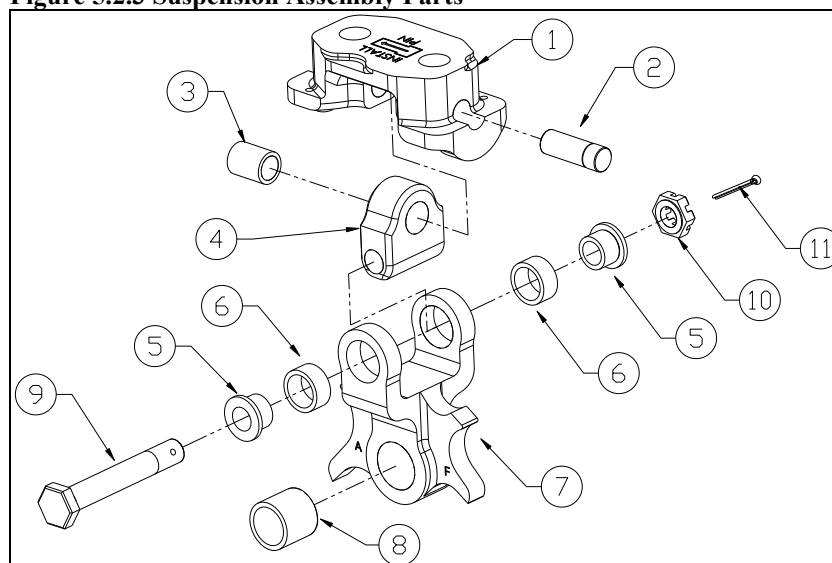

Table 5.2.2 Suspension Assembly Parts

ITEM	PART NO.	DESCRIPTION	QTY
1	291-108-01	Pillow Block	1
	291-108-00	Pillow Block	1*
2	291-536-00	Pin	1
	291-107-00	Pin	1*
3	291-109-00	Bushing	1
4	291-110-00	Gimbal	1
5	291-112-00	Bushing	2
6	291-111-00	Bushing	2
7	291-113-00	Load Link	1
8	290-364-00	Bushing	1
9	510-631-00	Bolt	1
10	510-634-00	Nut	1
11	510-081-00	Cotter Pin	1

* P/Ns 291-108-00 and 291-107-00 are superseded by P/Ns 291-108-01 and 291-536-00 respectively. P/N 291-108-01 Pillow Block must be used with P/N 291-536-00 Pin and P/N 291-108-00 Pillow Block must be used with P/N 291-107-00 Pin.

5.2 5 year/1000 Hour Inspection continued

Figure 5.2.4 Suspension Assembly Identification

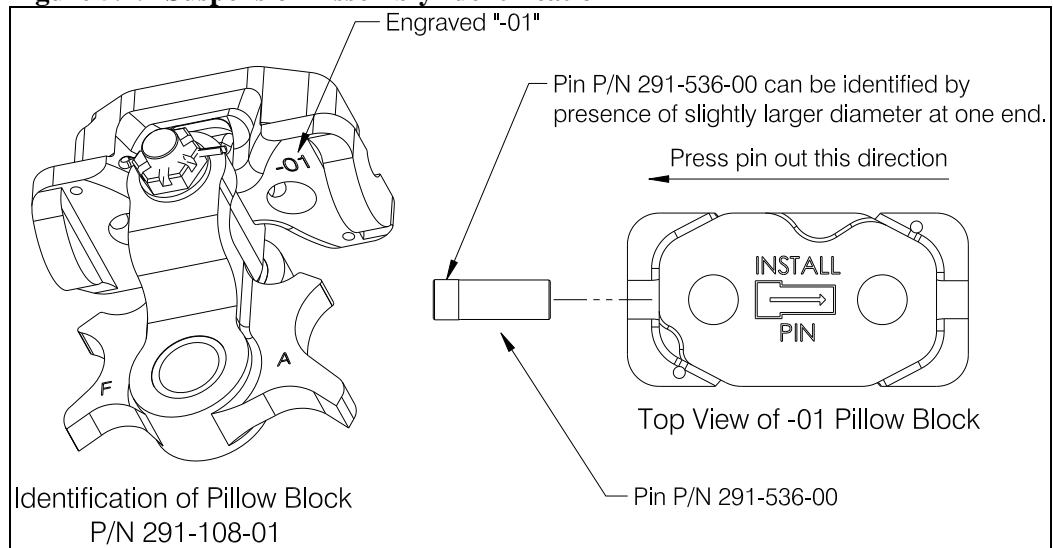

5.2 5 year/1000 Hour Inspection continued

Return the Pin Load Cell Assembly (P/N 210-301-01 or P/N 210-226-01) to the factory for inspection and calibration. The factory will inspect the condition of the load cell and perform acceptance test procedures including calibration and zero balance, repairing as necessary.

Carefully inspect and repair the suspension parts in accordance with the instructions in Table 5.2.3. Inspect the parts in a clean, well-lit room.

Table 5.2.3 Suspension System Inspection

Component	Inspection Criteria and Limit	Repair	Finish
Attach Bolt P/N 290-332-00	Wear on outside diameter – 0.495 in. (12.6 mm)	None.	N/A
Pin Load Cell P/N 210-301-01 or P/N 210-226-01	Wear on outside diameter – 0.495 in. (12.6 mm)	None.	N/A
Pillow Block P/N 291-108-01 or P/N 291-108-00	Dents, nicks, cracks, gouges, scratches and corrosion – 0.010 in. (0.25 mm) deep.	Glass bead blast at less than 30 PSI to remove corrosion. Blend out scratches, gouges, etc. at 10:1 ratio, length to depth, to provide smooth transitions.	Passivate per AMS- QQ-P-35 or ASTM A967.
Gimbal P/N 291-110-00	Dents, nicks, cracks, gouges, scratches and corrosion – 0.010 in. (0.25 mm) deep.	Glass bead blast at less than 30 PSI to remove corrosion. Blend out scratches, gouges, etc. at 10:1 ratio, length to depth, to provide smooth transitions.	Passivate per AMS- QQ-P-35 or ASTM A967.
Load Link P/N 291-113-00	Dents, nicks, cracks, gouges, scratches and corrosion – 0.010 in. (0.25 mm) deep.	Glass bead blast at less than 30 PSI to remove corrosion. Blend out scratches, gouges, etc. at 10:1 ratio, length to depth, to provide smooth transitions.	Passivate per AMS- QQ-P-35 or ASTM A967.
Gimbal Bushing P/N 291-109-00	Wear on inside diameter – 0.328 in. (8.3 mm).	None.	N/A
Bushing P/N 290-364-00	Wear on inside diameter – 0.520 in. (13.2 mm).	None.	N/A
Bushing P/N 291-111-00	Wear on inside diameter – 0.445 in. (11.3 mm).	None.	N/A
Pin P/N 291-107-00 P/N 291-536-00	Wear on outside diameter – 0.300 in. (7.6 mm).	None.	N/A
Flange Bushing P/N 291-112-00	Wear on outside diameter – 0.422 in. (10.7 mm).	None.	N/A
Bolt, nuts, washers, cotter pin, etc.	Wear, corrosion, or deterioration	None*.	N/A

5.3 Cargo Hook Overhaul Schedule

Overhaul the cargo hook in accordance with the guidelines below. Contact Onboard Systems for the latest revision of overhaul instructions for the cargo hook and guidance to locate authorized overhaul facilities.

Time Between Overhaul (TBO): 1000 hours of external load operations or 5 years, whichever comes first.

NOTICE

*Hours of external load operations should be interpreted to be (1) anything is attached to the primary cargo hook (whether or not a useful load is being transported) and (2) the aircraft is flying. If these conditions are **NOT** met, time does **NOT** need to be tracked.*

NOTICE

The C-40 Indicator (P/N 210-293-00) records and displays hours of external load operations accumulated. This resettable hour-meter automatically logs time when the external load goes above 50 lbs and stops counting when it goes under 25 lbs. For this method of tracking hours refer to the C-40 Owner's Manual for additional instructions.

This page intentionally left blank.

Section 11

Placards and Markings

11.1 Placards





As applicable, the cargo hook kits require that the placards shown in Table 11.1 be installed.

Table 11.1 Cargo Hook Kit Placards

Placard part number and appearance	Location
<p>P/N 215-110-00</p> <div style="border: 1px solid black; padding: 10px; text-align: center;"> <p>CARGO RELEASE</p> </div>	<p>Mounted adjacent to the cyclic release switch in clear view of the pilot.</p> <p>Mounted adjacent to the left seat release switch in clear view of the pilot (if optional left seat release switch is installed).</p> <p>Mounted adjacent to the mechanical release T-handle in clear view of the pilot.</p>
<p>P/N 215-111-00</p> <div style="border: 1px solid black; padding: 10px; text-align: center;"> <p>PULL</p> </div>	<p>Mounted adjacent to the mechanical release in clear view of the pilot.</p>
<p>P/N 215-112-00</p> <div style="border: 1px solid black; padding: 10px; text-align: center;"> <p>CARGO</p> </div>	<p>Mounted adjacent to the cargo hook circuit breaker in clear view of the pilot.</p>
<p>P/N 215-119-00</p> <div style="border: 1px solid black; padding: 10px; text-align: center;"> <p>EXTERNAL LOAD LIMIT = 800 LBS (363 KGS)</p> </div>	<p>Mounted on the belly of the aircraft adjacent to the cargo hook attachment point in clear view of the ground support personnel.</p>
<p>P/N 215-115-00</p> <div style="border: 1px solid black; padding: 10px;"> <p>FOR FAR PART 133.35(A) OPERATIONS: NO PERSON MAY BE CARRIED UNLESS HE IS: (1) A FLIGHT CREW MEMBER OR TRAINEE; (2) PERFORMS AN ESSENTIAL FUNCTION IN CONNECTION WITH THE EXTERNAL LOAD OPERATION; OR (3) IS NECESSARY TO ACCOMPLISH THE WORK ACTIVITY DIRECTLY ASSOCIATED WITH THAT OPERATION.</p> </div>	<p>Mounted on the instrument panel in clear view of the pilot.</p>

11.1 Placards continued

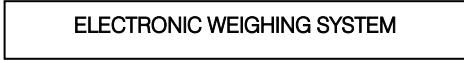
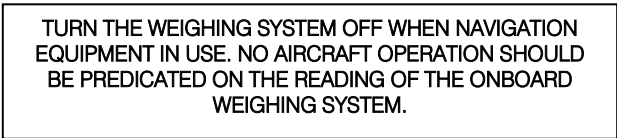
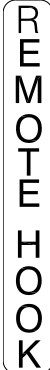
Table 11-1 Cargo Hook Suspension System Placards, continued

Placard part number and appearance	Location
<p>P/N 215-336-00</p> 	<p>Mounted on the bottom of solenoid housing of cargo hook P/N 528-029-02 (included with kit P/N 200-327-10 and 200-327-11 only).</p>
<p>P/N 215-343-00</p> 	<p>Located adjacent to the cargo hook release switch on the cyclic (included with kit P/N 200-327-10 and 200-327-11 only).</p>
<p>P/N 215-010-00</p> 	<p>When load weigh system is installed, mounted adjacent to both the power switch (C-39 model only) and the circuit breaker in full view of the pilot and co-pilot.</p>
<p>P/N 215-012-00</p> 	<p>When load weigh system with C-39 model indicator is installed, mounted adjacent to the indicator in full view of the pilot and co-pilot. This placard is not applicable to the C-40 indicator.</p>
<p>P/N 215-284-00 Multiple Placard Sheet</p> 	<p>When Onboard Systems 200-396-00 system is installed, mounted on the release switch housing on the cyclic (next to the remote release switch) in full view of the pilot and co-pilot.</p>
<p>P/N 215-284-00 Multiple Placard Sheet</p> 	<p>When Onboard Systems 200-396-00 system is installed, mounted adjacent to the remote cargo hook circuit breaker in clear view of the pilot and next to the belly mounted remote hook electrical connector.</p>

Section 25

Equipment and Furnishings



Un-commanded cargo hook release will happen if the manual release cable is improperly restrained. The cable must not be the stops that prevent the Cargo Hook from swinging freely in all directions. If the Cargo Hook loads cause the hook to strain against the manual release cable the swaged end of the cable may separate allowing the inner cable to activate the cargo hook manual release mechanism. The result is an un-commanded release. Ensure that no combination of suspension and Cargo Hook position is restrained by the manual release cable.

Figure 25.1 Un-commanded Cargo Hook Release

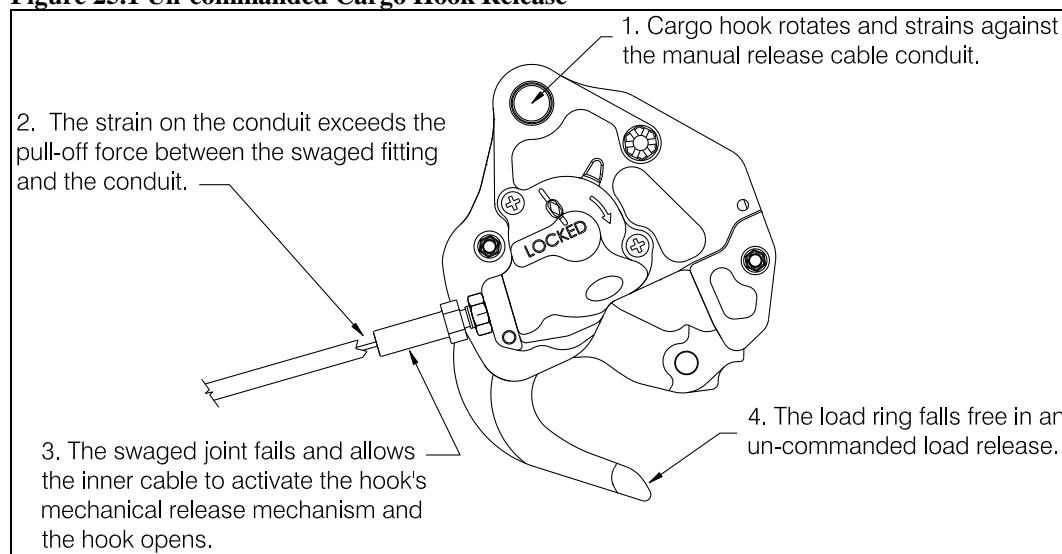

25.1 Cargo Hook Connector

Listed below is the pin out for the cargo hook connector.

Table 25.1 Cargo Hook Connector

Pin	Function
A	Ground
B	Positive

25.2 Description

The Cargo Hook Suspension Systems are comprised of:

- The cargo hook, which is mounted to the belly of the helicopter through a gimbaled suspension utilizing an existing hard point. The 200-324-00 kit features the 14V keepered cargo hook (P/N 528-010-06), the 200-325-00 kit features the 28V keepered cargo hook (P/N 528-010-04), the 200-326-00 kit features the 14V keeperless cargo hook (P/N 528-029-01), and the 200-327-00 features the 28V keeperless cargo hook (P/N 528-029-00).
- The P/N 200-325-01 and 200-327-01 cargo hooks suspension systems are the same as the 200-325-00 and 200-327-00 systems respectively except they include a load weigh system. The load weigh system provides a reading of the weight of the load being lifted to the pilot. It includes a pin load cell at the cargo hook, load indicator in the cockpit, and the interconnecting electrical wire harness. The P/N 200-327-02 and 200-327-12 cargo hook suspension systems include the newer C-40 indicator (replacing the C-39 indicator within the 200-327-01 and 200-327-11 systems).
- Kit P/Ns 200-327-10 and 200-327-11 include Cargo Hook P/N 528-029-02 with Surefire release as part of its electrical release system. Surefire release is a safety enhancement which requires the release switch to be held for approximately ½ second. This protects against inadvertent load release due to accidental contact with the release switch or mistaken actuation of the release switch when another is intended.
- An electrical release system that provides a means for releasing a load by pilot actuation of a push-button switch installed on the end of the cyclic grip assembly. The kits also include an optional push-button switch that is mounted on the outboard side of the co-pilot's seat. The electrical release system is powered from the bus through a 10 amp circuit breaker to a relay in the center tunnel. The switches control the relay and energize the DC solenoid in the Cargo Hook, opening the hook and releasing the cargo. A schematic for the electrical system is shown in Figure 25.3.
- A manual release system, which provides a means of releasing a cargo hook load in the event of an electrical release system failure. A T-handle mounted to the cyclic control cover actuates it.
- Ground personnel may also release a load by the actuation of a lever located on the side of the cargo hook.

An optional remote hook electrical release kit (P/N 200-396-00) is available for installation under this STC. This kit consists of the fixed electrical provisions for operation of a remote cargo hook. It includes an electrical release switch on the cyclic, circuit breaker, relay, connector on the belly, and the interconnecting wiring.

25.5 Component Weights

The weight and cg of the systems are listed in Table 25.2.

Table 25.2 System Weights and CGs

Kit P/N	Weight lbs (kgs)	STA in (mm)	BL in (mm)
200-324-00, 200-325-00, 200-326-00, 200-327-00, 200-327-10	5.3 (2.40)	93.9 (2385)	-4.1 (-104)
200-325-01, 200-327-01, 200-327-02, 200-327-11, 200-327-12	6.8 (3.10)	93.9 (2385)	-4.1 (-104)
200-324-00, 200-325-00, 200-326-00, 200-327-00 and 200-327-10 with cargo hook and suspension removed (see section 25.16 for removal instructions).	1.5 (0.68)	63.3 (1608)	-4.1 (-104)
200-396-00 (optional accessory kit)	1.1 (0.5)	63.3 (1608)	0.0

25.12 Storage Instructions

Refer to the cargo hook CMM for storage instructions for the cargo hook. Clean the exterior suspension components thoroughly of excess dirt and grease with a rag before packaging. Pack the unit in a heat-sealable package. If the unit is to be stored for long periods in a tropical climate it should be packed in a reliable manner to suit local conditions. Refer to MIL-PRF-23199 and MIL-STD-2073-1 for additional guidance.

Package the unit in a suitable fiberboard box and cushion the unit to prevent shifting. Seal the fiberboard box with tape and mark the box with the contents and date of packaging.

25.15 Trouble Shooting

Table 25.3 Troubleshooting

MALFUNCTION	PROBABLE CAUSE	CORRECTIVE ACTION
Cargo hook does not operate electrically or manually.	Defective internal mechanism.	Remove and replace cargo hook (see sections 25.16 and 25.17) or repair per CMM 122-001-00 or 122-017-00.
Cargo hook (except P/N 528-029-02) does not operate electrically, manual cable release operates normally.	Open electrical circuit, faulty wiring, circuit breaker, switch or solenoid.	Using multi-meter, check the resistance between pins A and B of electrical connector (see note 1 below). If open indication is obtained, remove and replace cargo hook (see sections 25.16 and 25.17). If switch is faulty, remove and replace per Sections 25.16 and 25.17.
Cargo hook P/N 528-029-02 (includes Surefire time delay circuit) does not operate electrically, manual release operates normally.	Release switch not held down long enough. Open electrical circuit, faulty wiring, circuit breaker, switch or solenoid.	Hold the release switch for a longer time. The time delay circuit incorporates an electronic delay of approximately ½ second after which time the hook solenoid will activate repeatedly. If the release switch is not held down long enough the cargo hook's solenoid will not activate. Check the aircraft circuit for opens and shorts by using a multi-meter on the hook connector. When the release switch is pressed 28V aircraft voltage should be present on the connector pins. Check the aircraft connector polarity. The time delay circuit is polarity sensitive and protected against reverse polarity. +28V should be on pin B and ground on pin A. Check the power pins on the hook itself. A multi-meter set to the kilo-ohms range should read between 2-8Kohms. Some auto-ranging meters will not read properly so be sure to try a manual kilo-ohms range. If the meter reads open or short there is a problem with the solenoid module itself and the hook should be replaced or repaired per its CMM.
Cargo hook operates electrically, but not manually.	Defective manual release cable. Defective manual release system.	Inspect manual release cable and cable connection to Cargo Hook. Remove and replace cargo hook (see Sections 25.16 and 25.17) or repair per CMM 122-001-00 or 122-017-00.
Load beam fails to re-latch after being reset.	Defective latch mechanism.	Remove and replace cargo hook (see sections 25.16 and 25.17) or repair per CMM 122-001-00 or 122-017-00.
Force required to release hook with T-handle on cyclic control cover exceeds 14 lbs (62.3 N).	High cable friction or friction in internal mechanism of hook.	Remove cable from hook and check cable and hook independently to determine cause. Remove and replace defective components per 25.16 and 25.17.
With release cable disconnected at hook, the force required to move T-handle on cyclic control cover exceeds 6 lbs (26.7 N).	Kinks or wear in cable, frozen water in cable, debris or damage to cable quick disconnect fitting or lever mechanism on cyclic	Inspect individual components to isolate problem. Remove and replace defective parts (see Sections 25.16 and 25.17 for removal and replace instructions for manual release cable).

25.15 Troubleshooting continued

Table 25.3 Troubleshooting

MALFUNCTION	PROBABLE CAUSE	CORRECTIVE ACTION
Cargo hook manual release cable pull-off force exceeds 8 lbs (35.6 N) at the hook.	Friction in internal mechanism.	Remove and replace cargo hook (see Section 25.16 and 25.17) or repair per CMM 122-001-00 or 122-017-00.
Circuit breaker opens when cargo hook is energized.	Short in the system, faulty wiring, circuit breaker or solenoid.	Check for shorts to ground along length of wire harness. Check solenoid resistance (see note 1), repair or replace defective parts.
Load Weigh Indicator does not light up.	Faulty wiring or circuit breaker.	Check the circuit breaker and wiring. If this doesn't help, remove and replace indicator per sections 25.16 and 25.17.
The displayed load on the Load Weigh Indicator is incorrect.	Incorrect calibration code.	Ensure the correct calibration code has been entered (refer to the applicable Owner's Manual for the Indicator).
C-39 model only: Load Weigh Indicator displayed load is not stable.	Dampening level is too small.	Adjust the dampening level to a larger number (refer to the Owner's Manual for the C-39 Indicator).
C-39 model only: Load Weigh Indicator displayed load takes too long to change the reading when the load is changed.	Dampening level is too large.	Adjust the dampening level to a smaller number (refer to the Owner's Manual for the C-39 Indicator).
Indicator displays large negative load	Indicator was zeroed under load.	Un-zero the indicator. Refer to applicable Owner's Manual for instructions.
C-40 Indicator analog bar not in sync with displayed load	Indicator is zeroed; analog bar always displays un-zeroed load.	Un-zero the indicator. Refer to the Owner's Manual for the C-40 Indicator.

Table 25.3 Notes:

1. Checking resistance at pins A and B.

Check for 3.0 to 4.0 ohms (cargo hook part numbers 528-010-04 and 528-029-00) or 1.2 to 1.6 ohms (cargo hook part numbers 528-010-06 and 528-029-01) between pins A and B of electrical connector located on the cargo hook (see below).

Figure 25.2 Cargo Hook Electrical Connector

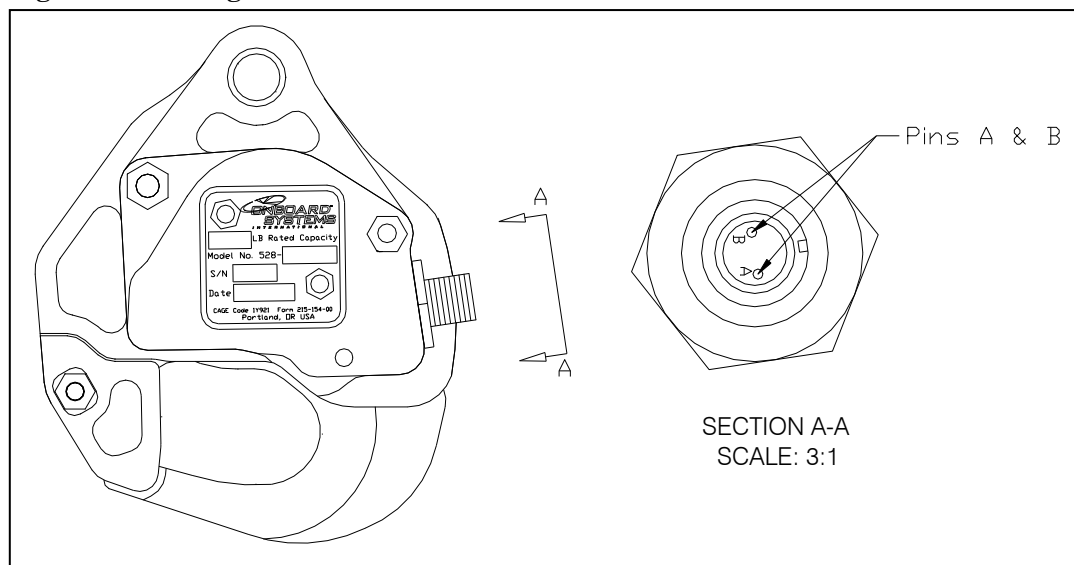

Table 25.3 Notes continued:

2. Electrical Wiring

Inspect wire harness for general condition and chafing along length of wire runs.

Figure 25.3 Electrical Release Schematic

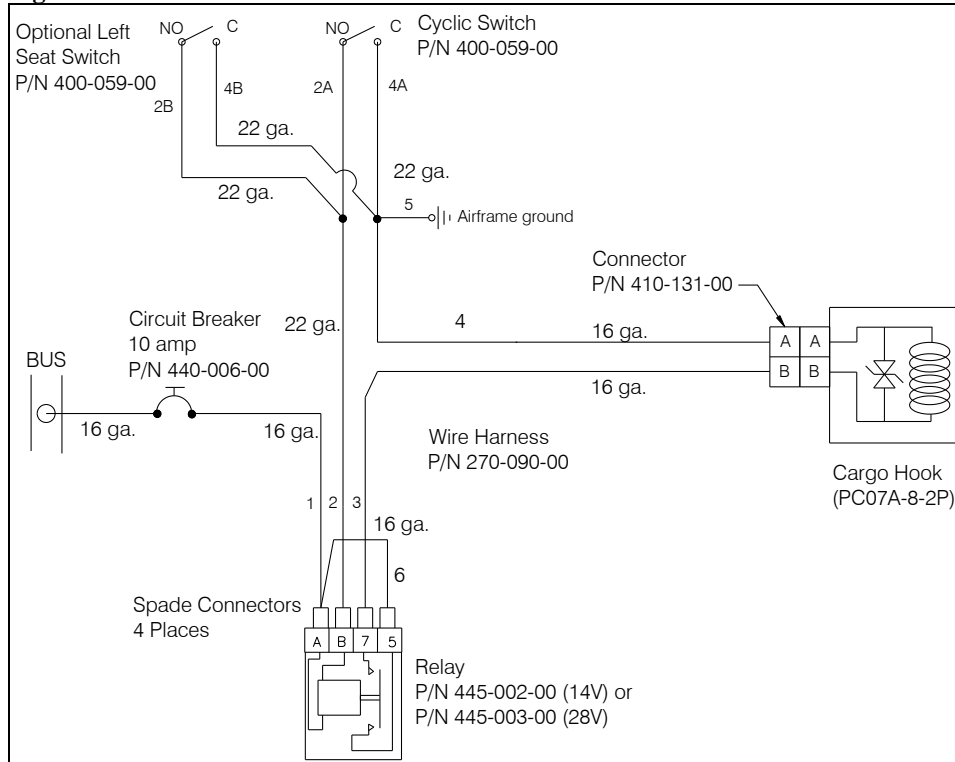
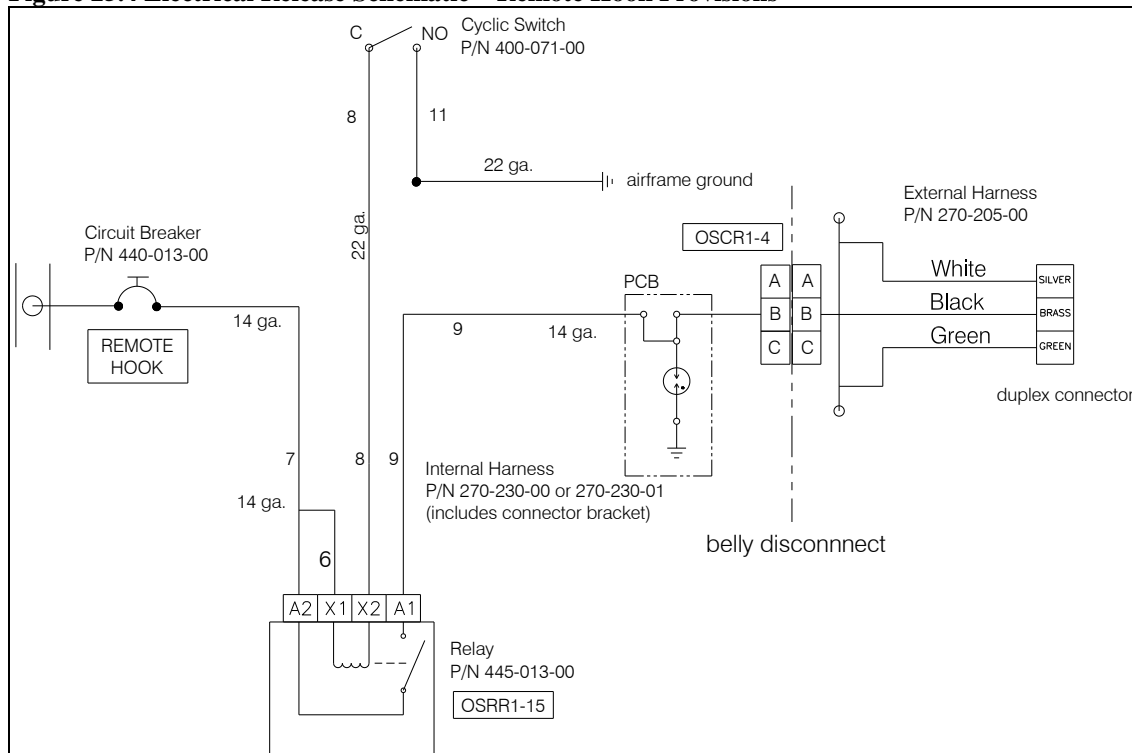

Figure 25.4 Electrical Release Schematic – Remote Hook Provisions



25.16 Component Removal

Cargo Hook and Pin Load Cell Assembly Removal

1. Disconnect the electrical connector from the cargo hook.
2. Remove the cotter pin P/N 510-178-00 from the Attach Bolt P/N 290-332-00 or Pin Load Cell Assembly (P/N 210-226-01 or P/N 210-301-01) if load weigh system is installed.
3. Remove the castellated nut P/N 510-170-00 from the Attach Bolt (or Pin Load Cell Assembly).
4. Remove attach bolt (or Pin Load Cell Assembly) and all washers.
5. Remove manual release cover by removing two screws.
6. Remove the manual release cable from the cargo hook by unhooking the cable ball end from the fork fitting on the manual release lever and loosening the jam nut and unthreading it by rotating the cargo hook about it.
7. Remove cargo hook from suspension system.

Suspension Removal

To remove the Suspension Assembly:

1. Remove the safety wire from the two Cap Screws and remove the Cap Screws that secure the Pillow Block to the aircraft hard point.
2. Separate the Suspension Assembly from the Pillow Block by removing the Pin from within the Pillow Block. The configuration with Pillow Block P/N 291-108-01 and Pin P/N 291-536-00 (see Figure 5.1.8 for identification) requires that the Pin be pressed out. Press pin out in the opposite direction of the "INSTALL PIN" engraving on top of the Pillow Block.

Figure 25.4 Suspension Removal

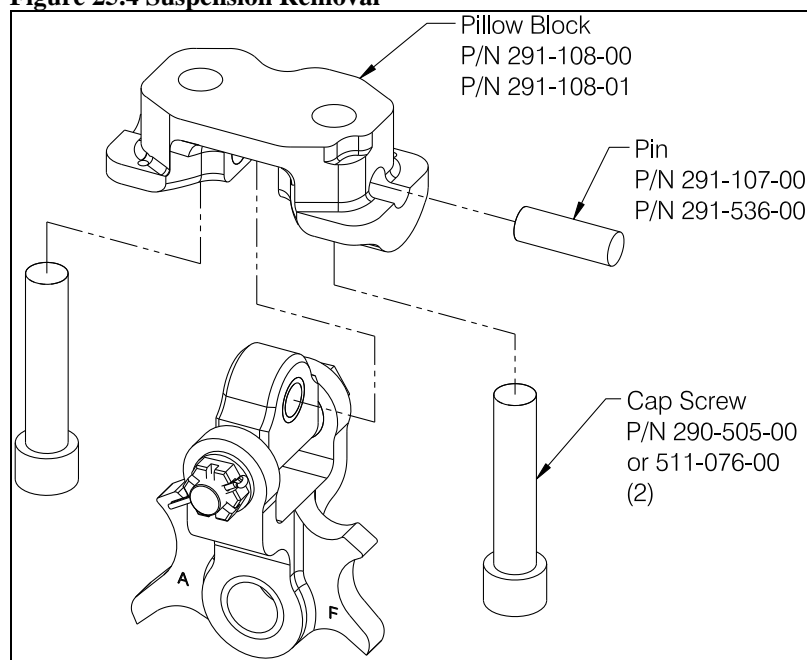

25.16 Component Removal continued

Manual Release Cable Removal

To facilitate access to the manual release cable, remove the forward of the two inspection panels on the belly of the aircraft.

1. In the cockpit unthread the T-handle and nut from the end of the release cable located on the cyclic control cover (ref. Figure 25.5).
2. Remove the loop clamp located on the tunnel keel panel underneath the cyclic control cover (ref. Figure 25.5).

Figure 25.5 Manual Release Cable

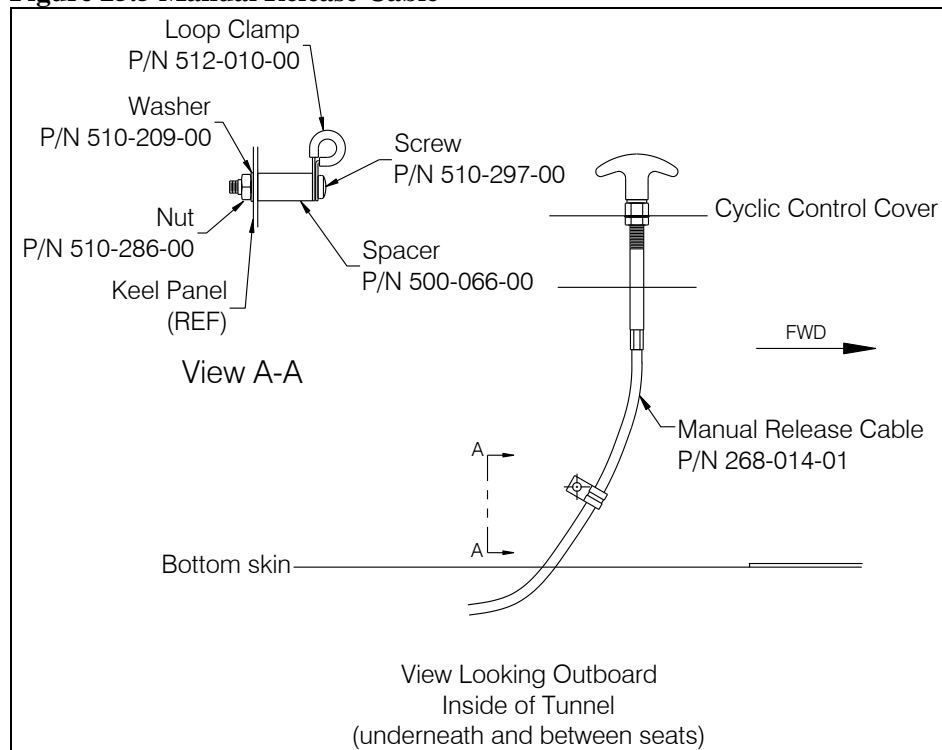

25.16 Component Removal continued

Manual Release Cable Removal continued

3. Pull the cable down through the cyclic control cover and through the grommet in the forward panel in the bottom skin (ref Figure 25.6) and remove the loop clamps at the forward and aft panels.

Figure 25.6 Manual Release Cable Exterior Routing

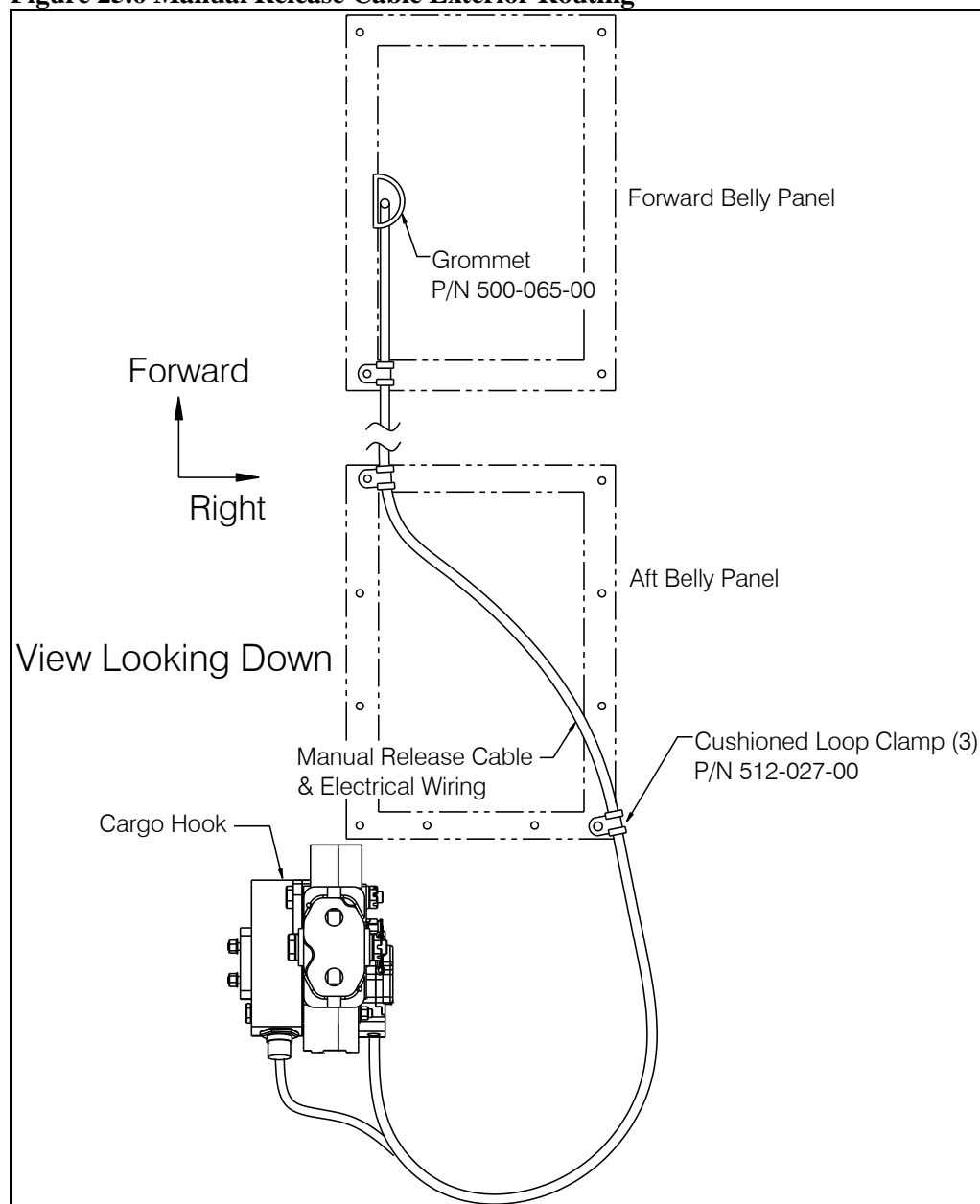

4. At the cargo hook remove the screws that secure the manual release cover to the hook and unhook the cable ball end from the fork fitting.
5. Loosen the jam nut and unthread the release cable from the hook.

25.16 Component Removal continued

Release Switch Removal

The release switch is located on the cyclic grip assembly. There are two different cyclic switch configurations (P/N 232-114-01 and P/N 232-152-01) to accommodate different configurations of the R44 cyclic.

1. Disconnect the battery.
2. Remove the nut that secures the Robinson start switch (the start switch is present on the R44 II only) on the end of the cyclic grip.
3. If start switch is present, loosen the set-screw that secures the start switch mount inside the end of the Switch Housing Assembly (P/N 232-152-01) and remove the switch mount.
4. Remove the screw that secures the Switch Housing Assembly to the cyclic grip and pull the switch housing out of the cyclic far enough to access the solder joint on wires 2A and 4A.
5. Remove the heat shrink over the solder joints and de-solder the joints.
6. Unthread the release switch (P/N 400-059-00) from the housing and pull the wires through.

Figure 25.7 Release Switch

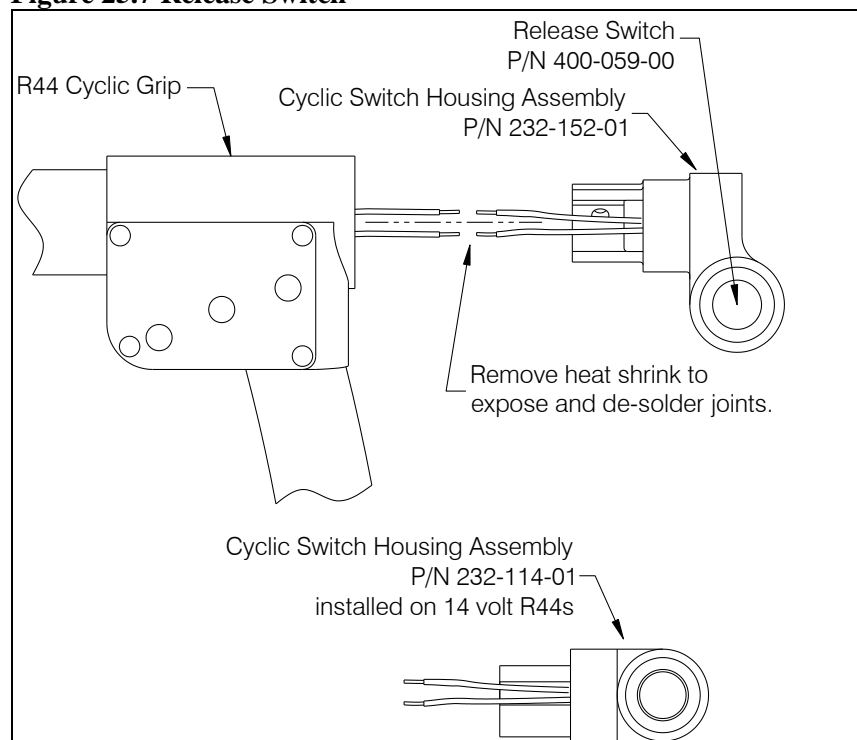

25.16 Component Removal continued

Left Seat Release Switch Removal

This is an optional installation; thus it may not be present on all helicopters with these cargo hook kits.

1. Disconnect the battery.
2. Hinge the seat bottom forward and reach under the seat to unthread the nut from the back of the switch.
3. Pull the switch out far enough to de-solder the wires from the back.

Figure 25.8 Left Seat Switch

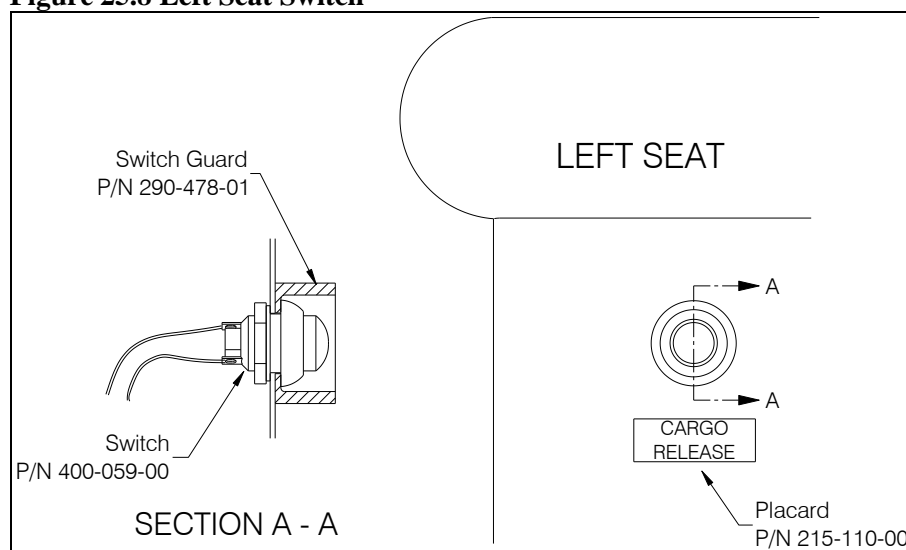

Remote Hook Release Switch Removal

The remote hook switch is included with the optional Remote Hook Electrical Release Kit. The remote hook switch is located within a housing to the left of the pilot's cyclic grip control housing.

1. Disconnect the battery.
2. Remove the cyclic control cover to access the wiring within the housing.
3. Locate the two wires from the remote hook switch, strip the heat shrink off, and de-solder the solder joints with the internal harness.
4. Remove the silicone from around the back of the switch and pull the wires through until they extend straight out the back of the housing.
5. Use a pair of needle-nose pliers to grab the back of the switch and unthread it from the housing.

25.16 Component Removal continued

Relay Removal

The relay (P/N 445-002-00 (14 volt) or P/N 445-003-00 (28 volt)) is located on the keel panel in the tunnel between the seats and below the floor (see below). To remove the relay:

1. Disconnect the battery.
2. Remove the 4 spade connectors at the relay.
3. Remove the two nuts, screws and washers.

Figure 25.9 Relay Location (Primary Hook Relay)

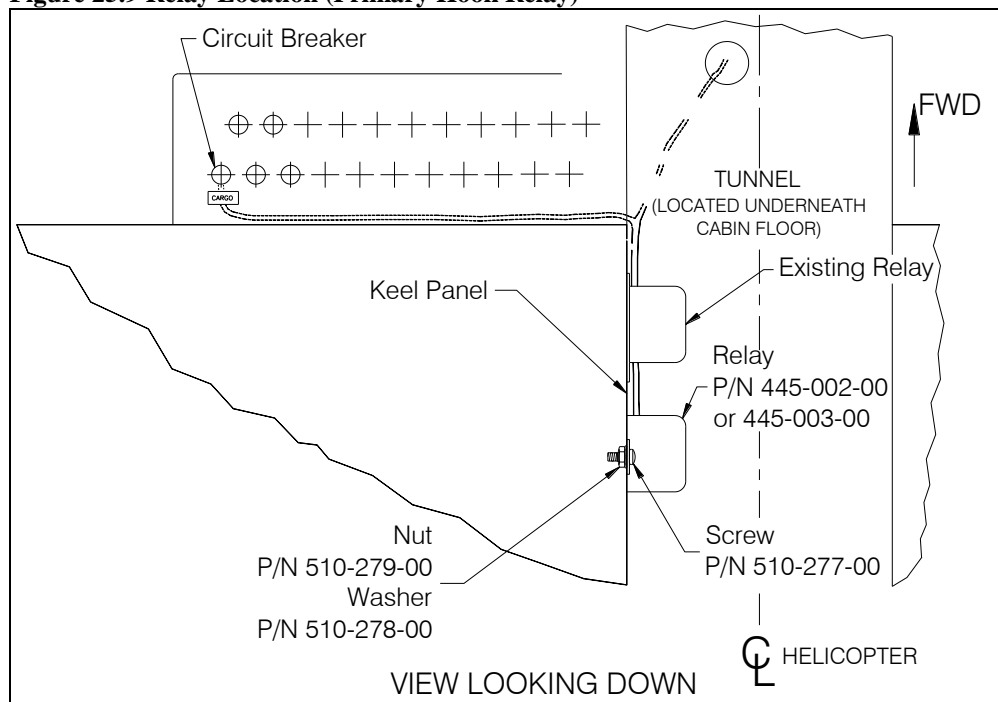

Remote Hook Relay Removal

The relay (P/N 445-013-00) for the remote hook is located on the connector bracket inside the aft end of the aft inspection panel opening in the belly.

1. Remove the aft inspection panel on the belly.
2. If necessary to facilitate removal of the relay remove the connector bracket from the belly by removing the three screws and lower the connector bracket as much as its connected wires allow.
3. Remove the two 4-40 nuts securing the relay to the studs of the relay socket and unplug the relay.

Load Weigh Indicator Removal

The load weigh indicator (if load weigh system is installed) location is optional within the cockpit.

1. Remove the four screws that secure the indicator in its position and remove the indicator.
2. Disconnect electrical connector from the back of indicator.

25.17 Component Re-installation

Suspension Re-installation

- Apply sealant to the side of the Suspension Assembly (P/N 232-292-01) Pillow Block which is to be installed against the belly skin.
- Orient the Suspension Assembly as shown in Figure 25.10 and secure it to the helicopter with the two P/N 290-505-00 or 511-076-00 cap screws. **

NOTICE

Install the Suspension Assembly so that the engraved "F" is forward and the engraved "A" is aft as shown in Figure 25.10.

- Torque screws to 26 ft-lbs.
 - Safety-wire the cap screws to the ears on the pillow block.
- ** If installing Suspension Assembly P/N 232-292-00, Pillow Block P/N 291-108-00, and Pin P/N 291-107-00 perform the following.

NOTICE

The Suspension Assembly P/N can be determined by checking the underside of the Pillow Block, P/N 232-292-01 Suspension Assembly has a "-01" on the underside of the Pillow Block.

- Grease the Pin (P/N 291-107-00) with Mobilgrease 28 or equivalent before assembly.
- Partially insert the Pin into the Pillow Block.
- Hold the Suspension Assembly (P/N 232-292-00) in the orientation as shown in Figure 25.11, position it within the slot of the Pillow Block, and slide the Pin through the Suspension Assembly and into the other side of the pillow block.

25.17 Component Re-installation continued

Suspension Re-installation continued

Figure 25.10 Suspension Assembly Installation – (P/N 232-292-01)

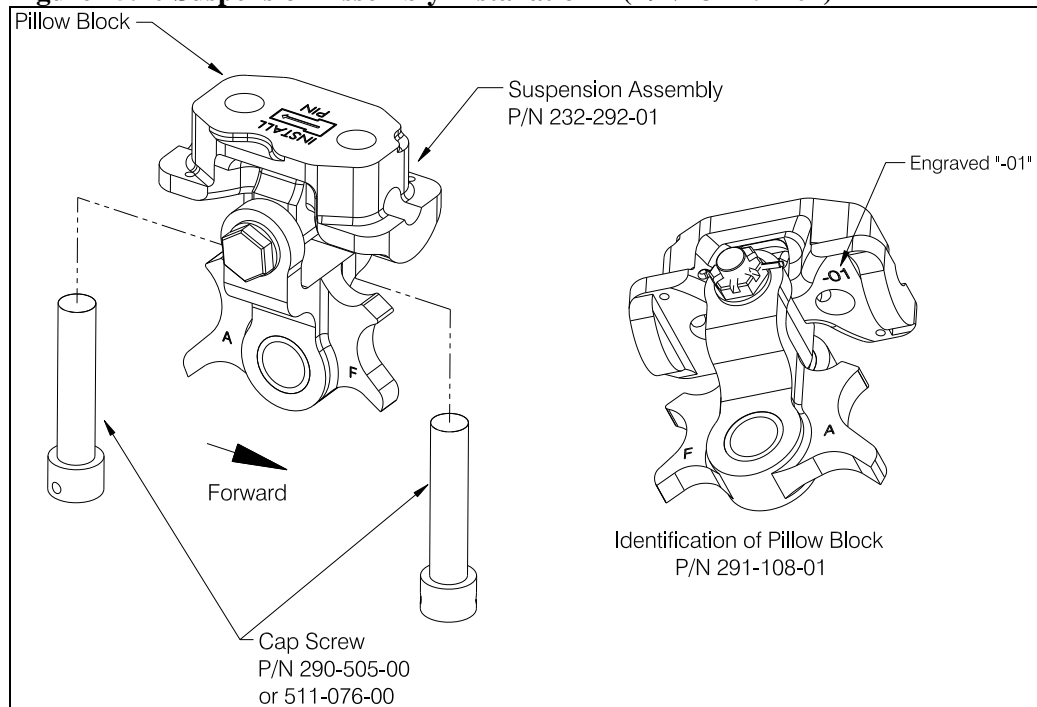
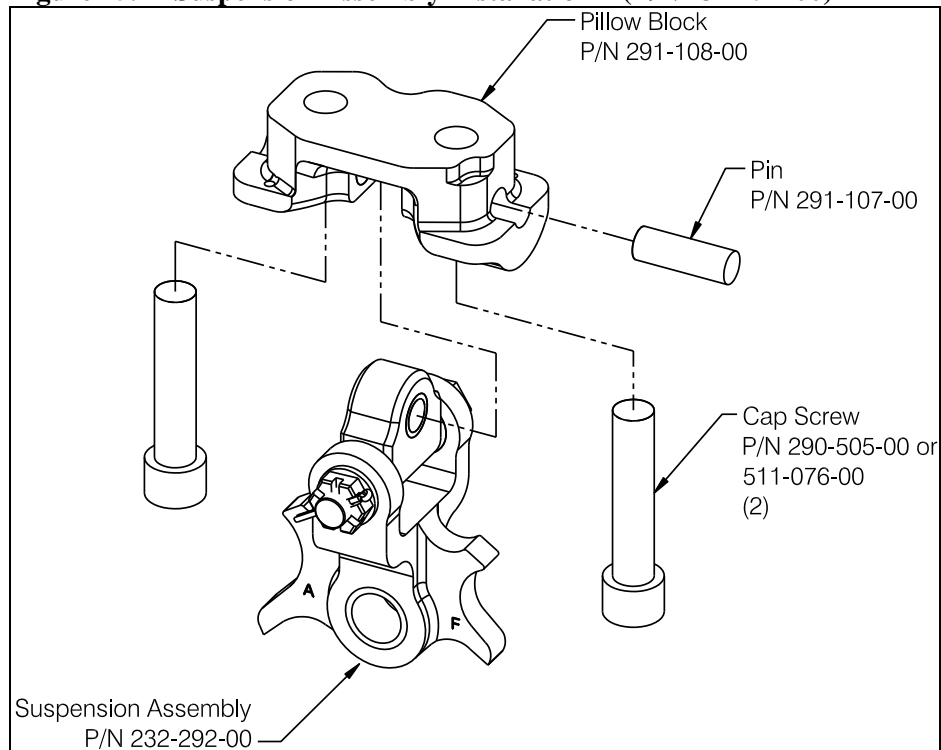

Figure 25.11 Suspension Assembly Installation – (P/N 232-292-00)



25.17 Component Re-installation continued

Cargo Hook Re-installation

1. Attach the Cargo Hook to the suspension system by installing the Attach Bolt P/N 290-332-00 and washer P/N 510-183-00 as illustrated in Figure 25.12. If the Pin Load Cell is installed refer to Figure 25.13.
2. Install washer P/N 510-183-00, washer P/N 510-174-00, and nut P/N 510-170-00 over bolt end (or pin load cell end).
3. Tighten nut on cargo hook attach bolt or pin load cell until fully seated, finger tight only. Back off nut to previous castellation, if needed, when aligning cotter pin for installation. Install and secure cotter pin.

CAUTION

Do not tighten nut on pin load cell more than finger tight. Over-tightening will damage load cell.

Figure 25.12 Cargo Hook Attachment Hardware

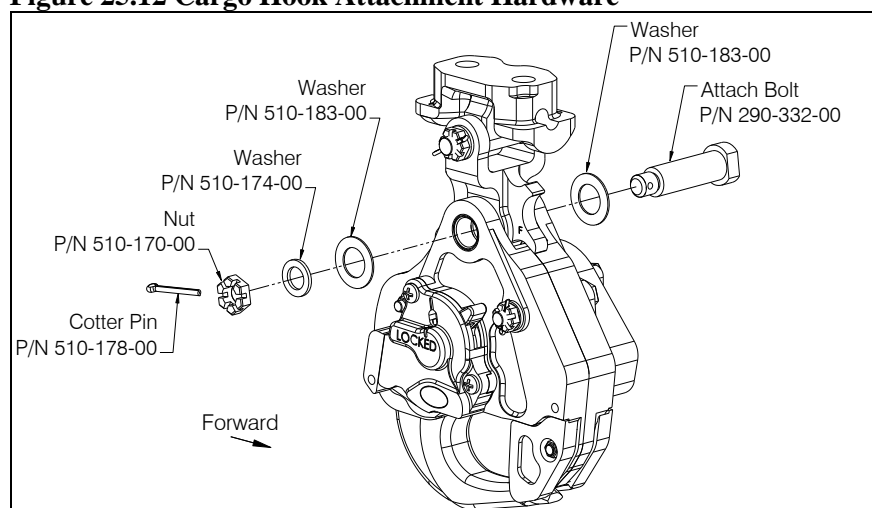
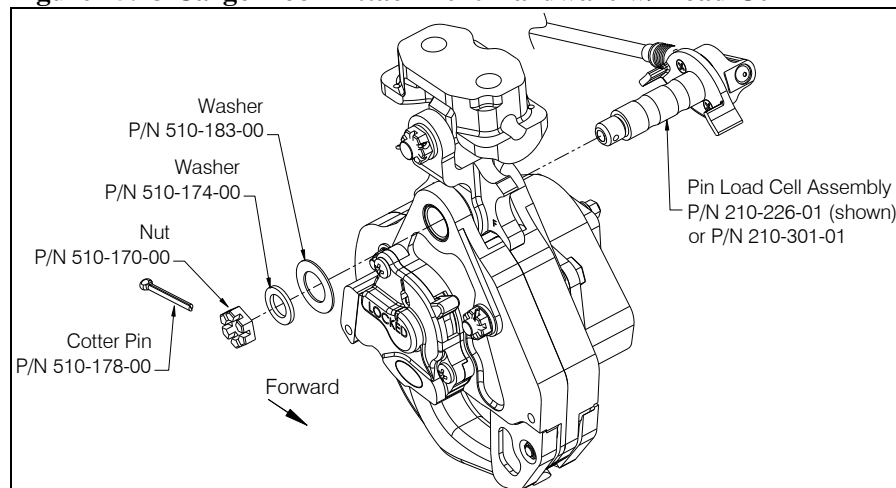

Figure 25.13 Cargo Hook Attachment Hardware w/ Load Cell



25.17 Component Re-installation continued

Manual Release Cable Re-installation

1. Route the cable forward through the loop clamps and grommet (ref Figure 25.6).
2. Route the cable through the loop clamp on the keel panel and to the hole in the cyclic control cover and secure with nut. Install T-handle (ref. Figure 25.5).
3. Remove the manual release cover from the cargo hook.
4. Screw the manual release cable into the cargo hook by holding the cable and turning the cargo hook or vice versa.
5. Temporarily install the cargo hook onto the suspension.



The cargo hook load beam must be closed and locked when rigging the manual release cable.

6. Rotate the release lever in the clockwise direction to remove free play and hold (the free play is removed when the hook lock indicator (528-029 series cargo hook only) begins to move). This is also readily felt as the lever rotates relatively easily for several degrees as the free play is removed.
7. Measure the gap between the release lever fork and the cable ball end with the T-handle in the cockpit in the non-release position. The gap should measure a minimum of .125" (see below).
8. If the gap does not measure at least .125", make adjustments at the cargo hook by removing the cargo hook from the suspension and rotating the cargo hook in the required direction.
9. When correct setting is achieved, tighten the jam nut securely against the cargo hook and re-install the manual release cover.

Figure 25.14 Manual Release Cable Rigging (528-029 series cargo hook shown)

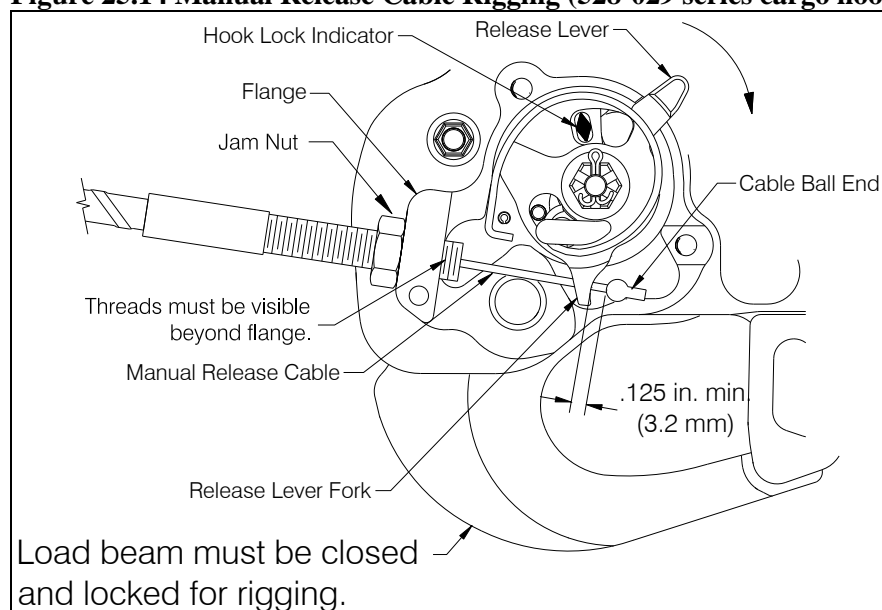

25.17 Component Re-installation continued

Release Switch Re-installation

1. Solder 22 AWG M22759 wires onto each switch terminal, thread switch into switch housing, and feed wires through the switch housing.
2. Slide 1" long piece of heat shrink over each wire and solder onto wires 2A and 2B that come up through cyclic. Position heat shrink over solder joints and shrink in place with heat gun.

Figure 25.15 Release Switch Installation

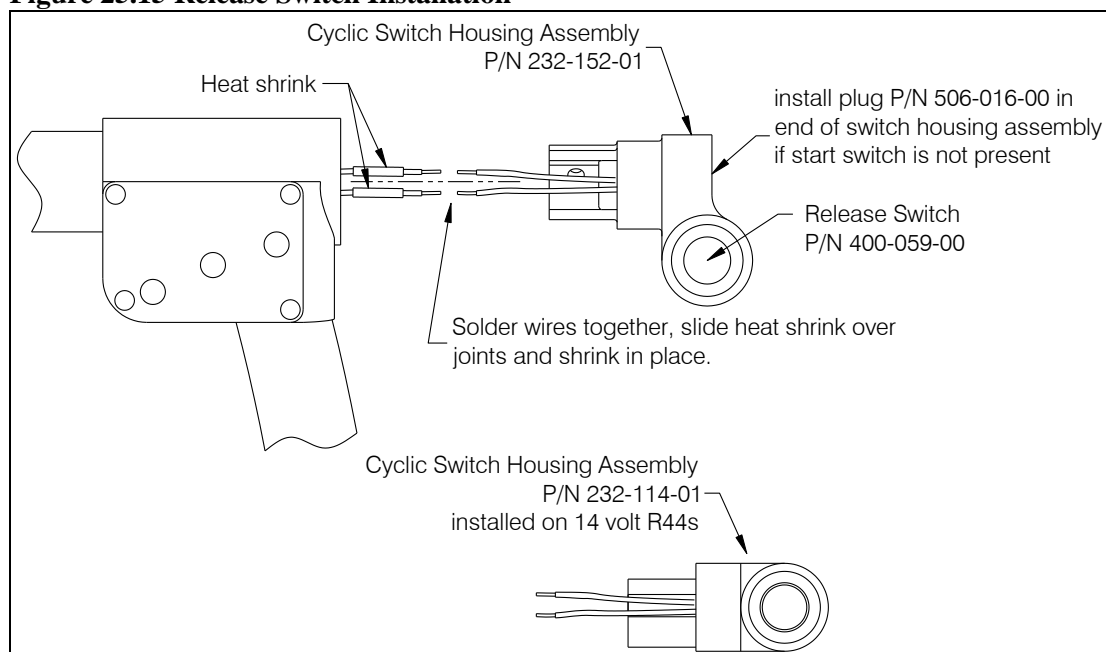

3. Insert switch housing assembly into end of cyclic while pulling the Robinson start switch through (start switch is applicable to R44 II only).
4. Secure switch housing assembly into cyclic with screw removed previously.
5. If present, place Robinson Switch Mount into switch housing and secure Start Switch into Switch Mount with nut removed previously. Secure Switch Mount in switch housing by tightening set screw.

NOTICE

Refer to Robinson maintenance documentation for part numbers for the Start Switch, Switch Mount, and associated hardware.

25.17 Component Re-installation continued

Left Seat Release Switch Re-installation

1. The left seat installation is an optional installation.
2. Feed electrical harness wires through nut (provided with switch P/N 400-059-00), up through hole in side of left seat, and through switch guard (P/N 290-478-01).
3. Solder wires onto switch (refer to Figure 25.3 for electrical schematic).
4. Insert switch through switch guard and into hole in side of seat.
5. Hold the switch and thread on the nut to secure.

Remote Hook Release Switch Re-installation

The remote hook release switch (included with the optional kit 200-396-00) is located on the pilot's cyclic, to the left of the control grip.

1. Thread the release switch into the housing, use a pair of needle nose pliers on the backside of the switch to thread it all the way in.
2. Solder two 5" long 22 AWG M22759 wires to the terminals on the back of the switch, slide 1" long pieces of 1/8" heat shrink over each wire and shrink in place over the solder joints. Feed the wiring through the hole in the switch housing. Use RTV silicone to secure the wires at the hole to prevent chafing.
3. Clamp the release switch housing assembly onto the cyclic with the two screws (P/N 511-011-00) and torque to 12-15 in-lbs.
4. Remove the cyclic control grip cover to access the wiring.
5. Feed the wiring from the switch through the hole in the cyclic housing, slide a piece of 1/8" heat shrink over each wire and solder to the wires from the internal harness (refer to wiring diagram in Figure 25.4). Slide heat shrink over solder joints and shrink into place.
6. Re-install cyclic cover (refer to Robinson Helicopter documentation).

Figure 25.16 Remote Hook Release Switch Location

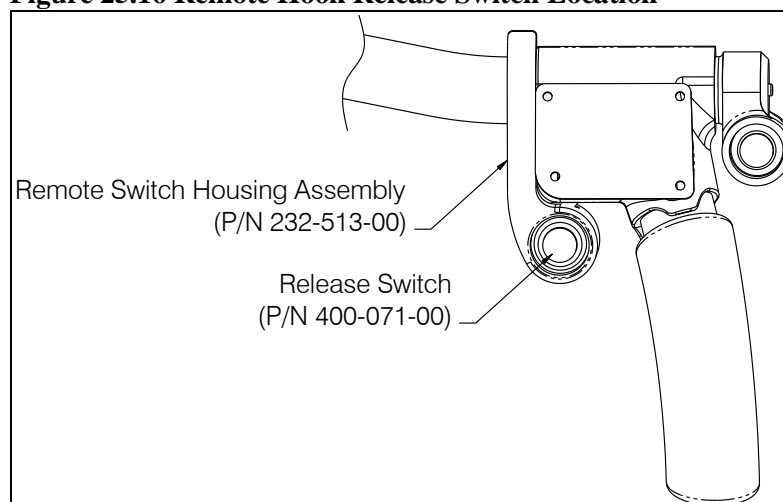

25.17 Component Re-installation continued

Relay Re-installation

1. Secure relay to keel panel in tunnel with two screws (P/N 510-277-00), washers (P/N 510-278-00), and nuts (P/N 510-279-00).
2. Connect the four spade connectors to the relay. Refer to electrical schematic (Figure 25.3) for pin out information.

Remote Hook Relay Re-installation

The remote hook relay (P/N 445-013-00) is installed on the Connector Bracket Assembly (P/N 270-230-00 or P/N 270-230-01*) located at the aft right corner of the aft inspection panel opening on the belly of the helicopter (see Figure 25.17 below). Install the relay per the following.

*P/N 270-230-01 supersedes P/N 270-230-00 and provides compatibility with Robinson panel P/N C794-3 with air inlet.

1. If necessary remove the Connector Bracket Assembly by removing its three mounting screws to facilitate installation of the relay.
2. Plug the relay into the relay socket located on the connector bracket assembly and secure with the two 4-40 nuts and washers removed previously (nuts and washers are provided with the relay socket).
3. Re-install aft inspection panel.

Figure 25.17 Remote Hook Relay Location

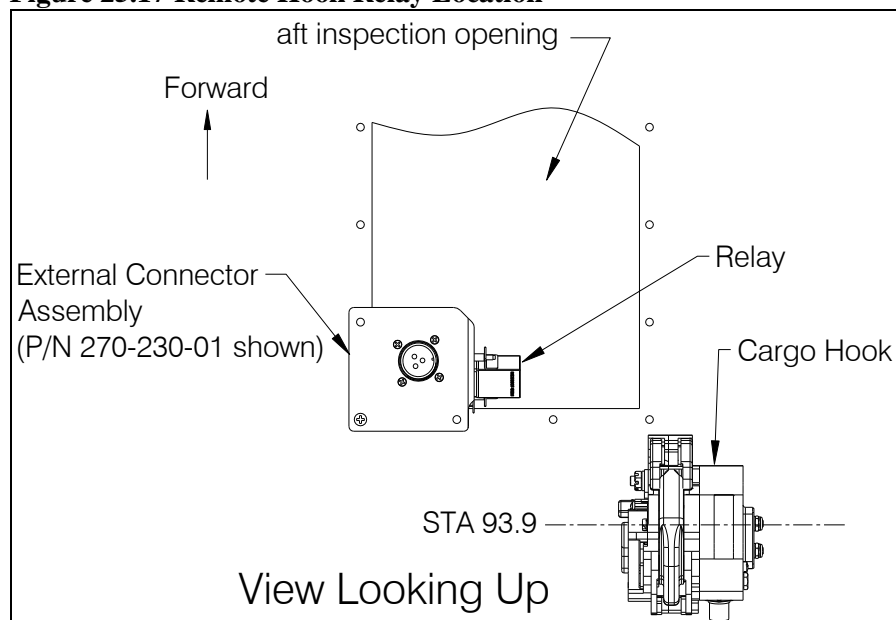

Load Weigh Indicator Re-installation

1. Place the Load Weigh Indicator into its mounting location and secure with four screws, P/N 511-211-00 for the C-40 Indicator, or another length of 6-32 MS35214 series screw as needed to accommodate thickness of the mounting panel. Tighten screws to 12-15 in-lbs.
2. Connect the electrical connector on the wiring harness to the connector on the back of the indicator.

25.18 General Procedural Instructions-Testing

After re-installation of the cargo hook or manual release cable, perform the following:

1. Activate the electrical system and press the Cargo Release button to ensure the cargo hook electrical release system is operating correctly. The cargo hook must release. Reset the hook by hand after release.



Energizing the cargo hook release solenoid continuously in excess of 20 seconds will cause it to overheat, possibly causing permanent damage.

The following instructions are applicable to cargo hook P/N 528-029-02 which is equipped with Surefire electrical release. With no load on the cargo hook perform the following.

- Very briefly press the Cargo Release switch, the cargo hook should not actuate and the load beam should remain closed.
 - Press and hold the Cargo Release switch for a few seconds, the load beam should fall to the open position and the cargo hook solenoid should continue to cycle repeatedly.
 - Push up on the load beam and verify that it latches and the hook lock indicator is aligned with the engraved line on the manual release cover (see Figure 5.1).
2. Activate the release T-handle located on the cyclic control cover to test the cargo hook manual release mechanism. The mechanism should operate smoothly and the cargo hook must release. For the 528-029 series keeperless cargo hooks reset the hook by hand after release. If the cargo hook does not release or re-latch, do not use the unit until the difficulty is resolved.
 3. Swing the installed Cargo Hook to ensure that the manual release cable assembly and the electrical release cable have enough slack to allow full swing of the suspension assembly without straining or damaging the cables. The cables must not be the stops that prevent the Cargo Hook from swinging freely in all directions.