

Please check web site at www.onboardsystems.com for
the latest revision of this manual

*Instructions for
Continued Airworthiness
Talon LC Keeperless
Cargo Hook Kit
for the
Eurocopter AS355 Series*

*System Part Number
200-352-00*

STC SR02035SE



*13915 NW 3rd Court Vancouver, Washington 98685 USA
Phone: 360-546-3072 Fax: 360-546-3073 Toll Free: 800-275-0883
www.OnboardSystems.com*

THIS PAGE INTENTIONALLY LEFT BLANK

RECORD OF REVISIONS

<i>Revision</i>	<i>Date</i>	<i>Page(s)</i>	<i>Reason for Revision</i>
0	11/18/09	All	Initial release.

THIS PAGE INTENTIONALLY LEFT BLANK

List of Effective Pages

<u>Title</u>	<u>Pages</u>	<u>Revision</u>	<u>Date</u>
Cover	<i>i, ii</i> Blank	0	11/18/09
Record of Revision	<i>iii, iv</i> Blank	0	11/18/09
List of Effective Pages	<i>v, vi</i> Blank	0	11/18/09
Table of Contents	<i>vii, viii</i> Blank	0	11/18/09
Section 0 Introduction 00-00-00	1, 2	0	11/18/09
Section 4 Airworthiness Limitations 04-00-00	1, 2 Blank	0	11/18/09
Section 5 Inspection and Overhaul Schedule 05-00-00	1 thru 4	0	11/18/09
Section 25 Equipment and Furnishings 25-00-00	1 thru 10	0	11/18/09

THIS PAGE INTENTIONALLY LEFT BLANK

CONTENTS

<u>Identification</u>	<u>Title, Page</u>
Section 0	Introduction 00-00-00
0.4	Scope, 1
0.5	Purpose, 1
0.6	Arrangement, 1
0.7	Applicability, 1
0.9	Abbreviations, 1
0.12	Precautions, 2
0.19	Distribution of Instructions for Continued Airworthiness, 2
Section 4	Airworthiness Limitations 04-00-00
Section 5	Inspection and Overhaul Schedule 05-00-00
5.1	Cargo Hook Inspection Schedule, 1
5.2	Cargo Hook Overhaul Schedule, 4
Section 25	Equipment and Furnishings 25-00-00
25.1	Cargo Hook Connector, 1
25.2	Description, 2
25.5	Component Weights, 4
25.12	Storage Instructions, 4
25.15	Trouble Shooting, 5
25.16	Component Removal, 6
25.17	Component Re-installation, 7
Figures	
5.1.1	Hook Lock Indicator, Chapter 5 Page 2
5.1.2	Side Plate Identification, Chapter 5 Page 2
5.1.3	Manual Release Cable Inspection, Chapter 5 Page 3
25.1	Un-commanded cargo hook release, Chapter 25 Page 1
25.2.1	Cargo Hook Overview, Chapter 25 Page 2
25.2.2	Primary Kit Components, Chapter 25 Page 3
25.16.1	Manual Release Cover Removal, Chapter 25 Page 6
25.16.2	Cargo Hook Connector, Chapter 25 Page 6
25.17.1	Cargo Hook Attachment Hardware, Chapter 25 Page 7
25.17.2	Manual Release Cable Adjustment, Chapter 25 Page 8
25.17.3	Manual Release Cable Connection, Chapter 25 Page 8
25.17.4	Manual Release Cable Rigging, Chapter 25 Page 9
Tables	
25.1.1	Cargo Hook Connector, Chapter 25 Page 1
25.2.1	Primary Kit Components, Chapter 25 Page 3
25.5.1	Component Weights, Chapter 25 Page 4
25.15.1	Troubleshooting, Chapter 25 Page 5

THIS PAGE INTENTIONALLY LEFT BLANK

Section 0

Introduction

0.4 Scope

The following information is necessary to carry out the service, maintenance, and inspection of the Cargo Hook Kit P/N 200-352-00.

0.5 Purpose

The purpose of this Instructions for Continued Airworthiness (ICA) manual is to provide the information necessary to service, maintain and inspect the P/N 200-352-00 Cargo Hook Kit in an airworthy condition.

0.6 Arrangement

This manual contains instructions for the service, maintenance, inspection and operation of Cargo Hook Kit P/N 200-352-00 (with cargo hook P/N 528-029-00) on Eurocopter AS355 series helicopters. The manual is arranged in the general order that maintenance personnel would use to maintain and operate the cargo hook in service.

The arrangement is:

Section 0 Introduction.

Section 4 Airworthiness Limitations (None apply to this kit)

Section 5 Inspection and Overhaul Schedule.

Section 25 Equipment and Furnishings

0.7 Applicability

These Instructions for Continued Airworthiness are applicable to kit P/N 200-352-00 on the Eurocopter AS355 series. Refer to the appropriate Eurocopter maintenance documentation for instructions regarding parts of the aircraft that interface with the cargo hook.

0.9 Abbreviations

FAA Federal Aviation Administration

CFR Code of Federal Regulations

ICA Instructions for Continued Airworthiness

0.12 Precautions

The following definitions apply to Warnings, Cautions and Notes used in this manual.



Means that if this information is not observed, serious injury, death or immediate loss of flight safety could occur.



Means that there is a risk of injury or degradation in performance of equipment if this information is not observed.



Draws the reader's attention to information which may not be directly related to safety, but which is important or unusual.

0.19 Distribution of Instructions for Continued Airworthiness

Before performing maintenance ensure that the Instructions for Continued Airworthiness (ICA) in your possession is the most recent revision. Current revision levels of all manuals are posted on Onboard Systems Int'l web site at www.onboardsystems.com. Also a Documentation Update Service is available on the web site. Registering for this service provides an e-mail or fax notification when a manual has been revised. Hard copies of all manuals are available from the factory, contact the factory at 800-275-0883 to request a copy.

Section 4

Airworthiness Limitations

The Airworthiness Limitations section is FAA approved and specifies maintenance required under 14 CFR §§ 43.16 and 91.403, unless an alternative program has been FAA approved.

No airworthiness limitations are associated with this type design change.

THIS PAGE INTENTIONALLY LEFT BLANK

Section 5

Inspection and Overhaul Schedule

5.1 Cargo Hook Kit Inspection Schedule

The scheduled inspection interval(s) presented below are maximums and are not to be exceeded. If the cargo hook is subjected to unusual circumstances, extreme environmental conditions, etc., it is the responsibility of the operator to perform the inspections more frequently to ensure proper operation. Refer to cargo hook service manual 122-017-00 for damage and wear tolerances.

Annually or 100 hours of external load operations*, whichever comes first, inspect the cargo hook kit per the following.

* “Hours of external load operations” is defined as the time in which a helicopter is engaged in external load operations. This includes time when a load is not on the hook.

1. Activate the helicopter’s electrical system and press the Cargo Release button to ensure the cargo hook electrical release is operating correctly. The cargo hook must release. Reset the cargo hook by hand after release. If the cargo hook does not release or re-latch, do not use the unit until the problem is resolved.



Actuating the electrical release switch continuously in excess of 20 seconds will cause the cargo hook release solenoid to overheat, possibly causing permanent damage.

2. Check the manual release system by pulling the release lever in the cockpit. The cargo hook must release. Reset the cargo hook by hand after release. Verify that the hook lock indicator on the side of the hook returns to the fully locked position. If the hook does not release or re-latch, do not use the unit until the problem is resolved.



In the fully locked position the hook lock indicator must align with the lines on the manual release cover (see Figure 5.1.1).

5.1 Cargo Hook Kit Inspection Schedule continued

Figure 5.1.1 Hook Lock Indicator

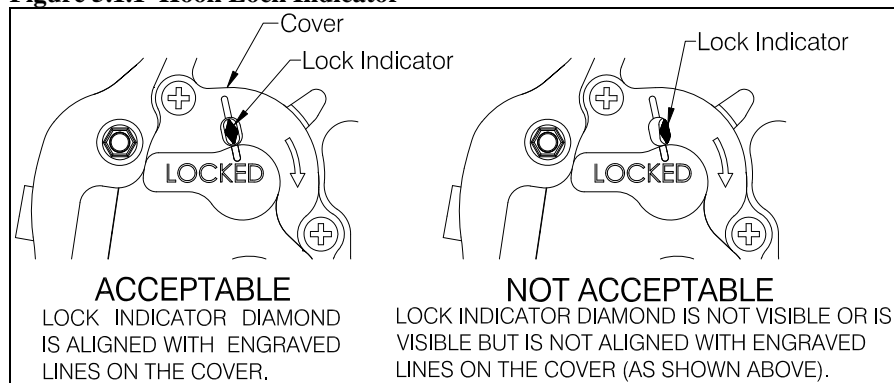

3. Visually inspect for corrosion on the exterior of cargo hook. Corrosion on the cargo hook side plates is cause for immediate overhaul. Additionally, any exfoliation corrosion in the upper attach lug area of the side plates is cause for immediate replacement of the side plate.

Figure 5.1.2 Side Plate Identification

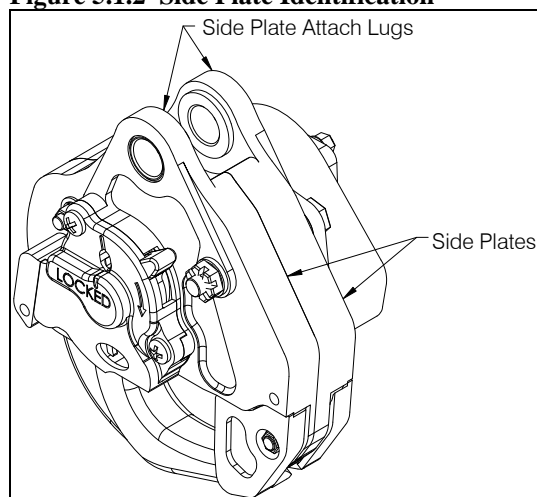

4. Move the cargo hook throughout its full range of motion to ensure the manual release cable and electrical harnesses have enough slack. The manual release cable or electrical harnesses must not be the stops that prevent the cargo hook from swinging freely in all directions.
5. Visually inspect for presence and security of fasteners and electrical connection.
6. Visually inspect the exterior of the cargo hook for damage including cracks, gouges, and nicks.
7. Visually inspect the cargo hook load beam for damage including cracks, wear, gouges, and nicks.
8. Visually inspect the cargo hook bumper for damage including cracks, gouges, and nicks.

5.1 Cargo Hook Kit Inspection Schedule continued

9. Visually inspect the manual release cable for damage, paying close attention to the flexible conduit at the area of transition to the cargo hook end fitting (refer to Figure 5.1.3). Inspect for splitting of the outer black conduit in this area and separation of the conduit from the steel end fitting.

Figure 5.1.3 Manual Release Cable Inspection

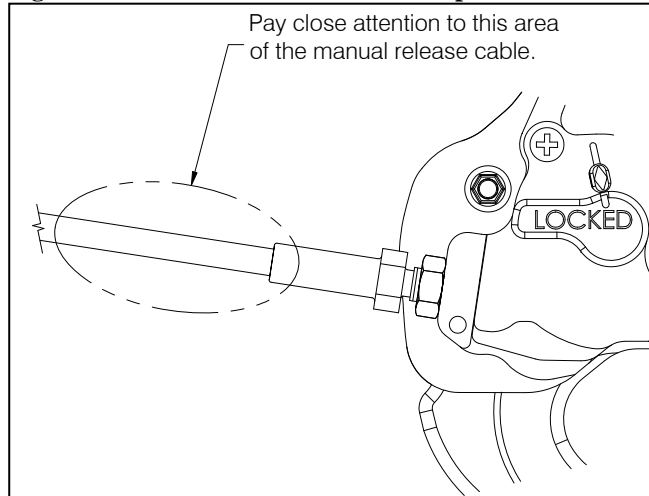

5.2 Cargo Hook Overhaul Schedule

Time Between Overhaul (TBO): 1000 hours (*) or 5 years, whichever is less.

(*) hours is defined as the time in which a helicopter is engaged in external load operations

Overhaul the cargo hook per service manual 122-017-00. Contact Onboard Systems for guidance to locate authorized overhaul facilities.

Section 25

Equipment and Furnishings



Un-commanded cargo hook release can occur if the manual release cable is improperly restrained. The cable must not be the stops that prevent the Cargo Hook from swinging freely in all directions. If the Cargo Hook loads cause the hook to strain against the manual release cable the swaged end of the cable may separate allowing the inner cable to activate the cargo hook manual release mechanism. The result is an un-commanded release. Ensure that no combination of cyclic stick or Cargo Hook position is restrained by the manual release cable.

Figure 25.1 Un-commanded Cargo Hook Release

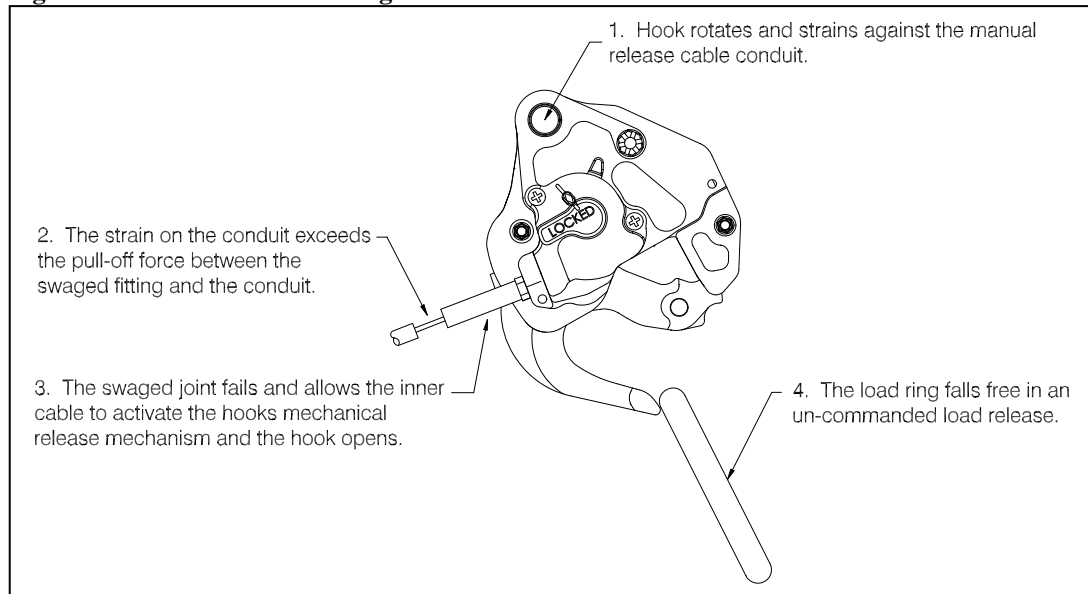

25.1 Cargo Hook Connector

Listed below is the pin out for the cargo hook connector.

Table 25.1.1 Cargo Hook Connector

Pin	Function
A	Ground
B	Positive

25.2 Description

The cargo hook is the means used to attach an external load to the aircraft. A load is attached to the cargo hook by passing a load ring into the throat of the load beam and pushing the ring against the upper portion of the load beam throat (see Figure 25.2.1), which will initiate the hook to close. In the closed position, a latch engages the load beam and latches it in this position. A load release can be initiated by three different methods. Normal release is achieved by pilot actuation of a push-button switch in the cockpit. When the push-button switch is pressed, it energizes the solenoid in the cargo hook, and the solenoid opens the latch in the internal mechanism. In the event of an electrical failure, load release can be achieved by operating the manual release cable. The release cable actuates the internal mechanism of the cargo hook to unlatch the load beam. A rigging window provides a means to verify the manual release cable setting with respect to the internal mechanism. Ground personnel can also release the load by actuating a manual release lever located on the side of the cargo hook (see Figure 25.2.1).

Figure 25.2.1 Cargo Hook Overview

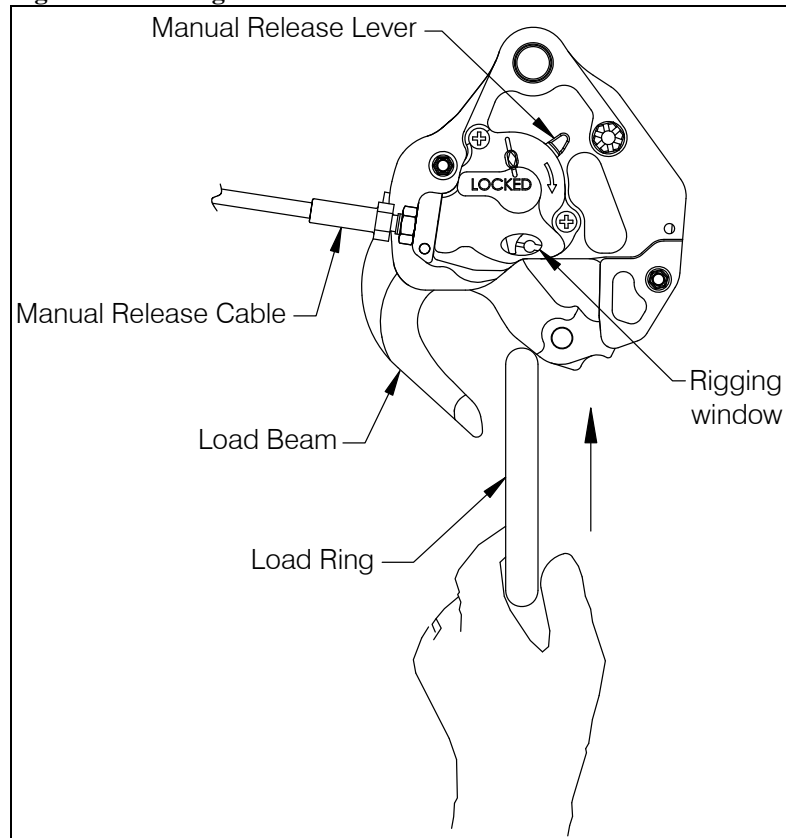

25.2 Description continued

The P/N 200-352-00 cargo hook kit includes the cargo hook, a cargo hook bumper, an electrical connector to splice into the helicopter's existing electrical release harness, and a manual release cable that connects to the helicopter's existing fixed manual release cable.

Figure 25.2.2 shows the primary components that make up the cargo hook kit. Miscellaneous items, hardware, etc. are not shown.

Figure 25.2.2 Primary Kit Components

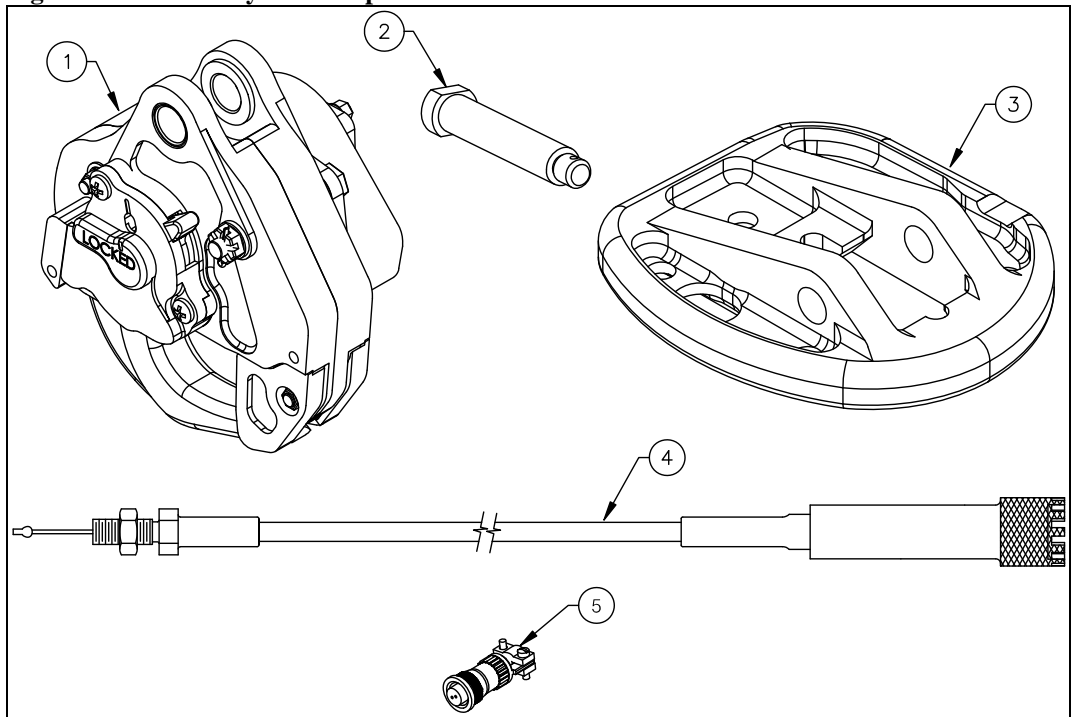

Table 25.2.1 Primary Kit Components

Item	Part No.	Description
1	528-029-00	Cargo Hook
2	290-775-00	Attach Bolt
3	290-773-00	Cargo Hook Bumper
4	268-030-01	Manual Release Cable
5	410-131-00	Electrical Connector

25.5 Component Weights

The weight of the Cargo Hook Kit and selected components is listed below.

Table 25.5.1 Component Weights

Item	Weight
Complete Cargo Hook Kit	4.3 lbs (1.95 kgs)
Cargo Hook (w/o attach hardware)	3.0 lbs (1.36 kgs)

25.12 Storage Instructions

Clean the exterior Cargo Hook components thoroughly of excess dirt and grease with a rag before packaging. Pack the unit in a heat-sealable package. If the unit is to be stored for long periods in a tropical climate it should be packed in a reliable manner to suit local conditions. Refer to MIL-PRF-23199E and MIL-STD-2073-1D for additional guidance.

Package the unit in a suitable fiberboard box and cushion the unit to prevent shifting. Seal the fiberboard box with tape and mark the box with the contents and date of packaging.

25.15 Trouble Shooting

Table 25.15.1 is provided with the intention of isolating the cause of malfunctions within the system. Sections 25.16 and 25.17 include instructions for removing and replacing defective components. Refer to the appropriate Eurocopter maintenance documentation for guidance on procedures relating to Eurocopter parts that interface with this suspension system.

Table 25.15.1 Trouble Shooting

MALFUNCTION	PROBABLE CAUSE	CORRECTIVE ACTION
Cargo hook does not operate electrically, manual cable release operates normally.	Open electrical circuit, faulty wiring, circuit breaker, switch or solenoid	Disconnect electrical connector at the Cargo Hook. Using multimeter, check for 3.0 to 4.0 ohms between pins A and B of electrical connector. If open indication is obtained, remove and replace cargo hook or replace solenoid per cargo hook service manual (document no. 122-017-00).
Cargo hook does not operate electrically or manually.	Defective internal mechanism	Remove and replace cargo hook or repair per the cargo hook service manual.
Cargo hook operates electrically, but not manually.	Defective manual release cable Defective manual release system	Check manual release cable and cable connection to Cargo Hook. Correct any defects. Remove and replace cargo hook or repair per the cargo hook service manual.
Load beam fails to re-latch after being reset.	Defective latch mechanism	Remove and replace cargo hook or repair per the cargo hook service manual.
Cargo hook manual release cable pull-off force exceeds 8 lbs. (at the hook).	Friction in internal mechanism.	Check operation of unit using manual release lever on the cargo hook. Remove and replace cargo hook or repair per the cargo hook service manual.
Failure to open or re-lock properly	Failure to open or re-lock properly	Remove and replace cargo hook or repair per the cargo hook service manual.
Circuit breaker opens when Cargo Hook is energized.	Short in the system, faulty wiring, circuit breaker or solenoid	Check for shorts to ground. Check solenoid resistance, repair or replace defective parts.

25.16 Component Removal

Cargo Hook Removal

1. Disconnect the electrical release harness from the cargo hook.
2. Remove the cotter pin P/N, 510-178-00, from the Attach Bolt, P/N 290-775-00.
3. Remove the castellated nut, P/N 510-170-00, from the Attach Bolt.
4. Remove Attach Bolt and all washers.
5. Remove manual release cover by removing two screws.

Figure 25.16.1 Manual Release Cover Removal

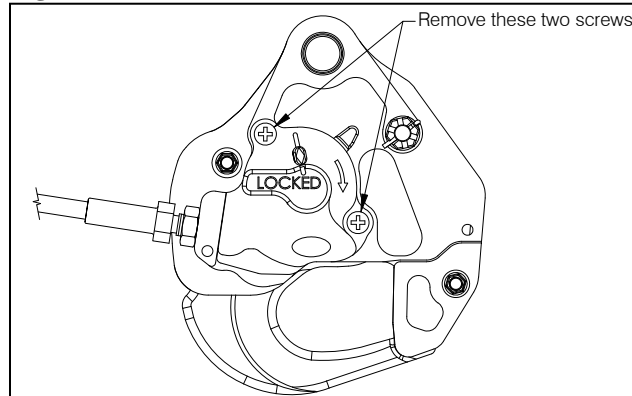

6. Unhook the manual release cable's cable ball end from the cargo hook's release mechanism, loosen the jam nut, and remove the manual release cable from the cargo hook by rotating the cargo hook.

Electrical Connector Removal

The kit supplied connector (P/N 410-131-00) replaces the connector on the end of the Eurocopter external harness.

1. Remove the two screws on the backshell that provide the clamp-up on the harness.
2. Unthread the backshell from the connector base to expose the solder contacts and de-solder the wires.
3. Cut safety wire and unthread the connector base from the cargo hook connector.

Figure 25.16.2 Cargo Hook Connector

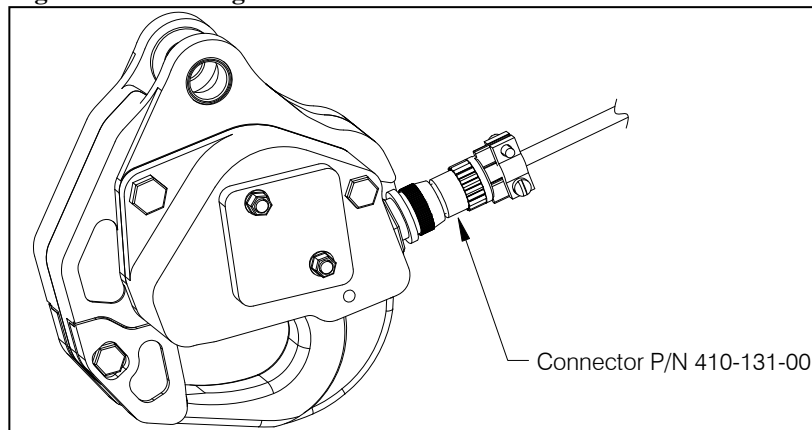

25.17 Component Re-installation

Cargo Hook Re-installation

1. Inspect the Cargo Hook for evidence of damage, corrosion and security of fasteners. If damage is evident, do not use the items until they are repaired.
2. Attach the Cargo Hook, P/N 528-029-00, to the load cell on the suspension system by installing the bumper, P/N 290-773-00, attach bolt, P/N 290-775-00 and washer, P/N 510-183-00, as illustrated in Figure 25.17.1.
3. Install washer, P/N 510-183-00, and washer, P/N 510-174-00, over bolt end.
4. Tighten nut, P/N 510-170-00, on bolt finger tight, then rotate nut to next castellation to install and secure cotter pin, P/N 510-178-00.

Figure 25.17.1 Cargo Hook Attachment Hardware

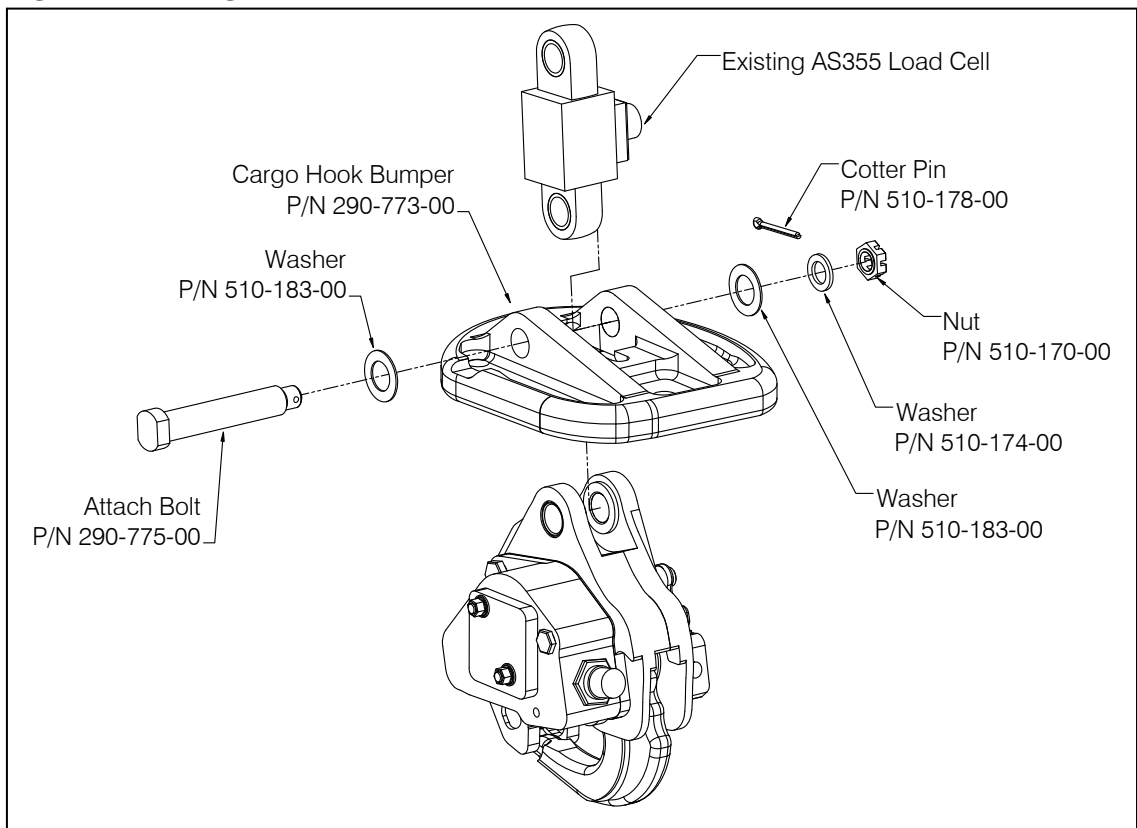

25.17 Component Re-installation continued

Cargo Hook Re-installation

Connect the manual release cable (P/N 268-030-01) to the cargo hook per the following instructions:

1. Remove the manual release cover from the cargo hook.
2. Thread the fitting at the end of the manual release cable into the manual release boss on the hook side plate until the threads protrude approximately .125 inches beyond the boss and secure with jam nut (as shown in Figure 25.17.2). Leave the cover off of the cargo hook until the other end of the release cable is connected, in order to verify proper setting.

Figure 25.17.2 Manual Release Cable Adjustment

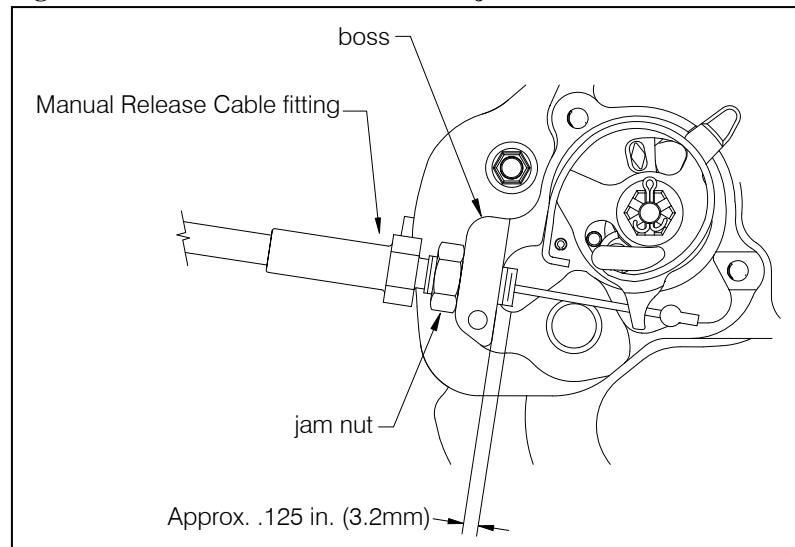

3. Connect the other end of the release cable to the fixed section of the AS355 manual release cable by mating the cable end fittings together as shown below. Slide the Adapter Fitting forward and thread it onto the existing AS355 fitting, and engage a castellation on the Adapter Fitting with the retaining pin to lock it in place.

Figure 25.17.3 Manual Release Cable Connection

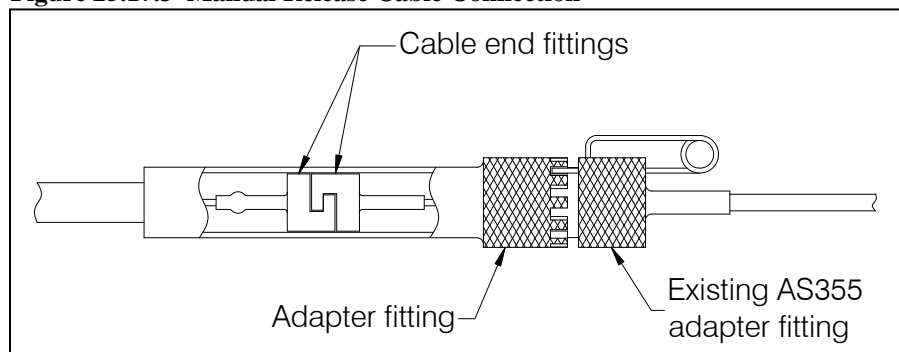

25.17 Component Re-installation continued

Cargo Hook Re-installation

- At the cargo hook, place the cable through the manual release lever fork as illustrated in Figure 25.17.4.



Manual release cable rigging must be done with the cargo hook in the closed and locked position.

- With the cargo hook in the closed and locked position, rotate the release lever in the clockwise direction to remove free play (the free play is taken up when the hook lock indicator begins to move) and measure the gap between the cable ball end and the release lever fork with the manual release handle in the cockpit in the non-release position. There must be a minimum of .125 inches (3.2 mm) between the cable ball end and fork fitting as shown in Figure 25.17.4. The maximum amount of free play is limited by the manual release cover, i.e. – the ball end must fit inside the manual release cover when it is installed.
- If necessary adjust the manual release cable system to obtain a minimum of .125 inches (3.2 mm). Some adjustment can be made at the cargo hook by loosening the jam nut and turning the manual release cable or cargo hook in the required direction and re-tightening the jam nut. Ensure the manual release cable fitting threads maintain full thread engagement with the cargo hook side plate boss (i.e.- the end of the threads should not be recessed within the boss). Tighten jam nut.
- Re-install the manual release cover with the two screws.

Figure 25.17.4 Manual Release Cable Rigging

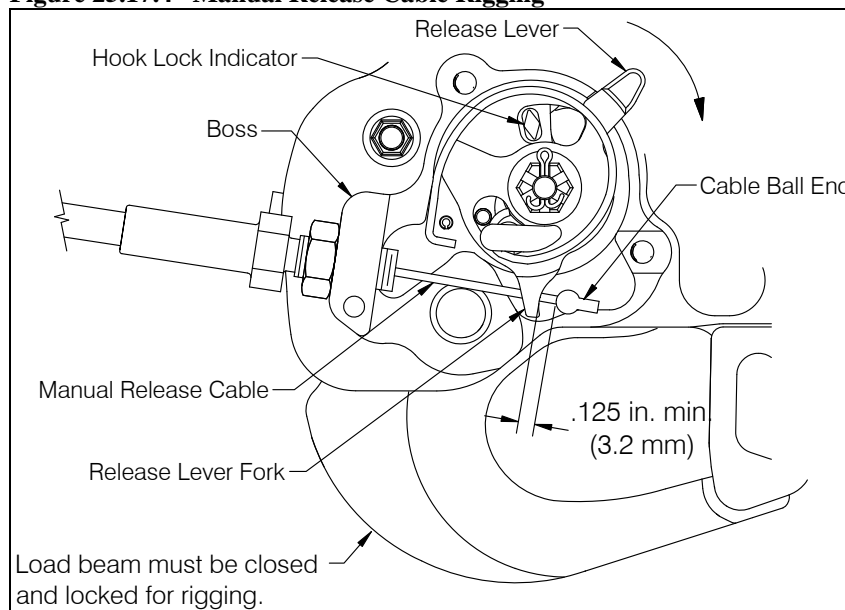

25.17 Component Re-installation continued

Electrical Connector Re-installation

The kit supplied connector (P/N 410-131-00) replaces the connector on the end of the Eurocopter external harness.

1. Slide the connector's backshell over the harness.
2. Solder the wire from pin L at the belly connector to pin B of the cargo hook connector and the wire from pin M at the belly connector to pin A of the cargo hook connector. Refer to Eurocopter Wiring Diagrams Manual for additional information on shipside wiring.
3. Thread the backshell onto the connector base and re-install the backshell clamp screws and tighten securely.
4. Thread the connector onto the cargo hook connector and safety wire.