

**Instructions for  
Continued Airworthiness**

**Dual Cargo Hook System**  
For the  
**MD Helicopters' 369D, 369E, 369F, 369FF, 500N, and 600N**

**System Part Number(s)**

**200-448-00**

**200-448-01**

**200-449-XX**

**200-383-00**

**200-383-01**

**STC SR02693LA**



13915 NW 3<sup>rd</sup> Court Vancouver, Washington 98685 USA  
Phone: 360-546-3072 Fax: 360-546-3073 Toll Free: 800-275-0883  
[www.OnboardSystems.com](http://www.OnboardSystems.com)

THIS PAGE INTENTIONALLY LEFT BLANK

## Record of Revisions

<i>Revision</i>	<i>Date</i>	<i>Page(s)</i>	<i>Reason for Revision</i>
0	11/14/18	All	First Issue
1	12/11/18	Section 4, Section 5	Added “FAA approved” statement and signature/date block to Section 4. Added reference to inspection table and clarification in item 8 of annual/100 hour inspection. Changed criteria for fluid leakage in item 10 of annual/100 hour inspection. Added a 5 year fluid replacement and re-organized Section 5.
2	02/25/20	Section 0 page 1, Section 6 pages 2, 3 thru 6, Section 25 pages 3, 4, 6, 8 thru 26	Added optional load weigh system and associated instructions.
3	08/17/21	Section 0 page 1, Section 5 page 5, Section 11, Section 25 pages 4, 9, 15, 17, 18, 22	Added kit P/Ns 200-448-01 and 200-383-01 for the 600N model and associated part numbers.

THIS PAGE INTENTIONALLY LEFT BLANK

## List of Effective Pages

<b>Title</b>	<b>Pages</b>	<b>Revision</b>	<b>Date</b>
Cover	i, ii Blank	3	08/17/21
Record of Revisions	iii, iv Blank	3	08/17/21
List of Effective Pages	v, vi Blank	3	08/17/21
Table of Contents	vii, viii, ix, x	2	02/25/20
Section 0 Introduction	1	3	08/17/21
Section 0 Introduction	2	0	11/14/18
Section 4 Airworthiness Limitations	1, 2 Blank	1	12/11/18
Section 5 Inspection and Overhaul Schedule	1	2	02/25/20
Section 5 Inspection and Overhaul Schedule	2	1	12/11/18
Section 5 Inspection and Overhaul Schedule	3, 4	2	02/25/20
Section 5 Inspection and Overhaul Schedule	5	3	08/17/21
Section 5 Inspection and Overhaul Schedule	6	2	02/25/20
Section 5 Inspection and Overhaul Schedule	7 thru 14	1	12/11/18
Section 11 Placards and Markings	1, 2	3	08/17/21
Section 12 Servicing	1 thru 12	0	11/14/18
Section 25 Equipment and Furnishings	1, 2	0	11/14/18
Section 25 Equipment and Furnishings	3	2	02/25/20
Section 25 Equipment and Furnishings	4	3	08/17/21
Section 25 Equipment and Furnishings	5	0	11/14/18
Section 25 Equipment and Furnishings	6	2	02/25/20
Section 25 Equipment and Furnishings	7	0	11/14/18
Section 25 Equipment and Furnishings	8	2	02/25/20
Section 25 Equipment and Furnishings	9	3	08/17/21
Section 25 Equipment and Furnishings	10 thru 14	2	02/25/20
Section 25 Equipment and Furnishings	15	3	08/17/21
Section 25 Equipment and Furnishings	16	2	02/25/20
Section 25 Equipment and Furnishings	17, 18	3	08/17/21
Section 25 Equipment and Furnishings	19 thru 21	2	02/25/20
Section 25 Equipment and Furnishings	22	3	08/17/21
Section 25 Equipment and Furnishings	23 thru 26	2	02/25/20

THIS PAGE INTENTIONALLY LEFT BLANK

# CONTENTS

<b><u>Identification</u></b>	<b><u>Title, Page</u></b>
<b><i>Section 0</i></b>	<b>Introduction</b>
	0.4 Scope, 1
	0.5 Purpose, 1
	0.6 Arrangement, 1
	0.7 Applicability, 1
	0.9 Abbreviations, 1
	0.12 Precautions, 2
	0.19 Distribution of Instructions for Continued Airworthiness, 2
<b><i>Section 4</i></b>	<b>Airworthiness Limitations</b>
<b><i>Section 5</i></b>	<b>Inspection and Overhaul Schedule</b>
	5.1 Annual/100 Hour Inspection, 1
	5.2 5 Year/1000 Hour Inspection, 4
	5.3 Long Line Kit Inspection, 7
	5.4 Cargo Hook Overhaul Schedule, 14
<b><i>Section 11</i></b>	<b>Placards and Markings</b>
	11.1 Placards, 1
<b><i>Section 12</i></b>	<b>Servicing</b>
	12.1 Maintenance of the Hydraulic Release System, 1
	12.2 Bleeding Hydraulic System, 5
	12.3 Lubrication Information, 10
<b><i>Section 25</i></b>	<b>Equipment and Furnishings</b>
	25.2 Description, 1
	25.5 Component Weights, 4
	25.12 Storage Instructions, 4
	25.15 Troubleshooting, 5
	25.16 Component Removal, 9
	25.17 Component Re-installation, 15

***Figures***

- 5.1.1 Hook Lock Indicator, Section 5 Page 2
- 5.2.1 Cargo Hook Installation Components/Disassembly, Section 5 Page 4
- 5.3.1 Long Line Kit Components, Section 5 Page 7
- 5.3.2 Rigging Plate Inspection Criteria, Section 5 Page 13
- 12.1.1 Checking Hydraulic Fluid Level, Section 12 Page 1
- 12.1.2 Master Cylinder Lever Disconnect, Section 12 Page 2
- 12.1.3 Master Cylinder Piston Removal, Section 12 Page 3
- 12.1.4 Master Cylinder Piston Seal Orientation, Section 12 Page 3
- 12.1.5 Slave Cylinder Piston Removal, Section 12 Page 4
- 12.2.1 Hydraulic Hook Bleed Kit Section 12 Page 5
- 12.2.2 Hose Arrangement, Section 12 Page 6
- 12.2.3 Reservoir Disassembly, Section 12 Page 6
- 12.2.4 Screw and Stat-o-seal Removal, Section 12 Page 7
- 12.2.5 Injecting Hydraulic Fluid, Section 12 Page 7
- 12.2.6 Screw Re-installation, Section 12 Page 8
- 12.2.7 Checking System for Air, Section 12 Page 9
- 12.3.1 Lubrication Points, Section 12 Page 10
- 25.2.1 Dual Cargo Hook Configuration, Section 25 Page 1
- 25.2.2 Cargo Hook PQRS and BQRS Controls, Section 25 Page 2
- 25.2.3 Hardpoint Fittings, Section 25 Page 3
- 25.15.1 Cargo Hook Electrical Connector, Section 25 Page 6
- 25.15.2 Electrical Schematic, Section 25 Page 7
- 25.15.3 Electrical Schematic (Load Weigh System), Section 25 Page 8
- 25.16.1 Attach Point Assembly Removal (Primary), Section 25 Page 9
- 25.16.2 Slave Cylinder Assembly Removal, Section 25 Page 10
- 25.16.3 Master Cylinder & Plumbing Overview, Section 25, Page 11
- 25.16.4 Master Cylinder Removal, Section 25, Page 12
- 25.16.5 Secondary Cargo Hook Relay Location, Section 25 Page 13
- 25.16.6 Release Switch Removal, Section 25 Page 14
- 25.17.1 Primary Attach Point Re-installation, Section 25, Page 15
- 25.17.2 Secondary Attach Point Re-installation, Section 25, Page 16
- 25.17.3 Cargo Hook Orientation, Section 25, Page 17
- 25.17.4 Cargo Hook Attachment Hardware, Section 25, Page 18
- 25.17.5 Cargo Hook Attachment w/ Pin Load Cell, Section 25 Page 18
- 25.17.6 Slave Cylinder Assembly Installation, Section 25 Page 19
- 25.17.7 Hydraulic Hose & Electrical Harness Routing, Section 25 Page 20
- 25.17.8 Hose and Harness Routing from Secondary Hook, Section 25 Page 21
- 25.17.9 External Hose and Harness Routing, Section 25 Page 22
- 25.17.10 Hydraulic Release System Installation, Section 25 Page 24
- 25.17.11 Lever Adjustment, Section 25 Page 25
- 25.17.12 Relay Re-installation, Section 25 Page 26



***Tables***

- 5.2.1 Cargo Hook Installation Parts, Section 5 Page 5
- 5.2.2 Dual Cargo Hook Suspension Inspection Criteria, Section 5 Page 6
- 5.3.1 Long Line Kit Parts, Section 5 Page 8
- 5.3.2 Long Line Kit Inspection Criteria, Section 5 Page 12
- 11.1 Cargo Hook Kit Placards, Section 11 Page 1
- 25.5.1 Component Weights and CGs, Section 25 Page 4
- 25.15.1 Troubleshooting, Section 25 Page 5

THIS PAGE INTENTIONALLY LEFT BLANK

# *Section 0*

## Introduction

### 0.4 Scope

The following information is necessary to carry out the service, maintenance, and inspection of the Dual Cargo Hook System P/N 200-448-00 and P/N 200-448-01, Long Line Kit P/N 200-449-XX, and optional Pin Load Weigh Kit P/Ns 200-383-00 and 200-383-01. See Section 25.2 for a detailed description of these P/Ns.

### 0.5 Purpose

The purpose of this Instructions for Continued Airworthiness (ICA) manual is to provide the information necessary to inspect, service, and maintain the dual cargo hook system and long line kit in an airworthy condition.

### 0.6 Arrangement

This manual contains instructions for the service, maintenance, inspection and operation of the part numbers listed above and as installed on MD Helicopters (MDHI) 369D, 369E, 369F, 369FF, 500N and 600N model helicopters. The manual is arranged in the general order that maintenance personnel would use to maintain the Dual Cargo Hook System and Long Line Kit in service.

The arrangement is:

- Section 0 Introduction.
- Section 4 Airworthiness Limitations
- Section 5 Inspection and Overhaul Schedule
- Section 11 Placards and Markings
- Section 12 Servicing
- Section 25 Equipment and Furnishings

### 0.7 Applicability

These Instructions for Continued Airworthiness are applicable to Dual Cargo Hook System P/Ns 200-448-00 and 200-448-01, Long Line Kit P/N 200-449-XX, and Pin Load Weigh Kit P/Ns 200-383-00 and 200-383-01 for the MD Helicopters 369 series, 500N, and 600N model helicopters. Refer to the appropriate MD Helicopter maintenance documentation for instructions regarding parts of the aircraft that interface with these parts.

### 0.9 Abbreviations

- FAA Federal Aviation Administration
- FAR Federal Aviation Regulation
- ICA Instructions for Continued Airworthiness
- CMM Component Maintenance Manual

## 0.12 Precautions

The following definitions apply to safety labels used in this manual.



Indicates a hazardous situation which, if not avoided, will result in death or serious injury.



Indicates a hazardous situation which, if not avoided, could result in death or serious injury.



Indicates a hazardous situation which, if not avoided, could result in minor or moderate injury.



Draws the reader's attention to important or unusual information not directly related to safety.



Used to address practices not related to personal injury.

## 0.19 Distribution of Instructions for Continued Airworthiness

Before performing maintenance ensure that the Instructions for Continued Airworthiness (ICA) in your possession is the most recent revision. Current revision levels of all manuals are posted on Onboard Systems Int'l web site at [www.onboardsystems.com](http://www.onboardsystems.com).

Onboard Systems offers a free notification service via fax or e-mail for product alerts and documentation updates. By registering Onboard Systems products on the web site, we will be able to contact you if a service bulletin is issued, or if the documentation is updated.

Notices can be chosen to be received on an immediate, weekly, or monthly schedule via fax, email or both methods. There is no charge for this service. Please visit the Onboard Systems web site at [www.onboardsystems.com/notify.php](http://www.onboardsystems.com/notify.php) to get started.

## Section 4

# Airworthiness Limitations

The Airworthiness Limitations section is FAA approved and specifies inspections and other maintenance required under Secs. 43.16 and 91.403 of the Federal Aviation Regulations unless an alternative program has been FAA approved.

The following items of the Long Line Kit are life-limited. Captured metal parts (load rings, snap hooks, etc.) of the assemblies are also scrapped at retirement.

Part Number	Description	Maximum Service Life**
490-014-00	Y-Rope	4 years
490-015-XX*	Long Line	4 years
490-018-00	Lanyard	4 years

\*The XX represents length of the long line in feet divided by 10, e.g. - a 100 foot long line has a part number 490-015-10, a 150 foot long line has a part number 490-015-15, etc.

\*\* Service life begins when the item is placed into service. This date must be marked by the operator in the reserved location on the component ID tag or using another method such as recording in a log book.

**FAA Approved:** This page constitutes the Airworthiness Limitations Section in its entirety, is considered segregated from the rest of the document, and sets forth the FAA approved mandatory replacement times for the life-limited parts listed above.

Approved By:  Date: 2/21/2019  
Manager, Los Angeles Certification Office

THIS PAGE INTENTIONALLY LEFT BLANK

## Section 5

# Inspection and Overhaul Schedule

The scheduled inspection intervals are maximums and are not to be exceeded. If the cargo hook system is subjected to unusual circumstances, extreme environmental conditions, etc., it is the responsibility of the operator to perform the inspections more frequently to ensure proper operation.

There is no maintenance to be performed on the Load Weigh Indicator of the load weigh system (if installed). Do not open the enclosure, if repair is needed return it to the factory.

### 5.1 Annual/100 Hour Inspection

---

**Annually or 100 hours of external load operations, whichever comes first, inspect the cargo hook system per the following. Refer also to the cargo hook's Component Maintenance Manual (manual no. 122-015-00) for additional inspection.**

---

## NOTICE

*Hours of external load operations should be interpreted to be (1) anything is attached to the cargo hook (whether or not a useful load is being transported) and (2) the aircraft is flying. If these conditions are **NOT** met, time does **NOT** need to be tracked.*

1. Activate the helicopter's electrical system and press the pushbutton switch for the primary cargo hook (the primary cargo hook switch is the original MDHI switch on the cyclic labeled "HOOK RELEASE") to ensure the cargo hook electrical release system is operating correctly. The cargo hook must open. Reset the hook by hand after release.

Repeat for the secondary cargo hook using the pushbutton switch integrated into the release lever installed on the cyclic labeled "SECONDARY HOOK RELEASE".

## CAUTION

*Depressing the cargo release button continuously in excess of 20 seconds will cause the cargo hook solenoid to overheat, possibly causing permanent damage.*

## 5.1 Annual/100 Hour Inspection continued

2. Check the function of the primary cargo hook's hydraulic release system by pulling the inboard release lever on the cyclic. The lever should operate smoothly and the primary (forward) cargo hook must release. Return the load beam to its closed and locked position by hand after release. Verify that the hook lock indicator on the side of the hook returns to the fully locked position. In the fully locked position the hook lock indicator must align with the lines on the cover (see Figure 5.1.1).

Repeat using the outboard lever on the cyclic for the secondary (aft) cargo hook.

**Figure 5.1.1 Hook Lock Indicator**

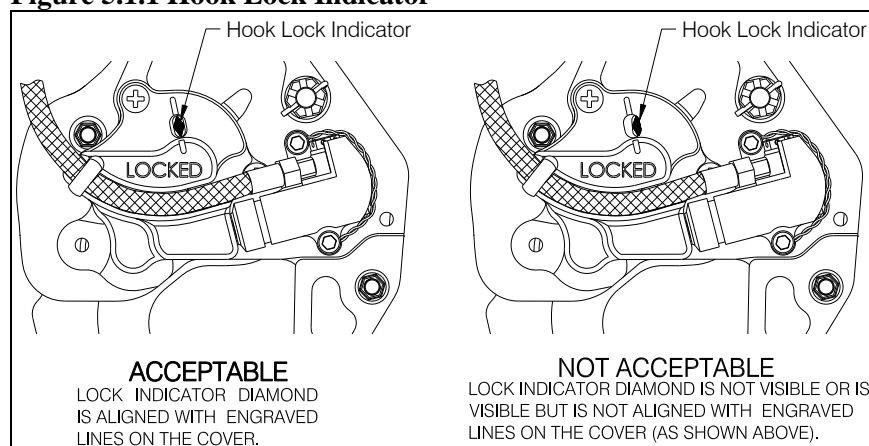

3. Move each cargo hook throughout its full range of motion and observe the hydraulic hose and electrical harnesses to ensure that they have enough slack. The hose or harness must not be the stops that prevent each cargo hook from moving freely in all directions.
4. Rotate pivoting joints at each cargo hook attachment to ensure that they rotate freely throughout their range of motion.
5. Visually inspect for presence and security of fasteners.
6. Visually inspect the external electrical harnesses and their connectors at the cargo hooks and at the fixed connectors on the belly for damage and security.
7. Visually inspect each external hydraulic hose and the connections to the cargo hooks and the fixed fittings on the belly for damage and security.
8. Visually inspect for cracks and damage in the Pillow Block and Pivot Link of the attach point assemblies. Refer to Table 5.2.2 for inspection criteria.



**5.1 Annual/100 Hour Inspection** continued

9. Inspect for security of the Dual Master Cylinder on the cyclic.
10. Visually check for fluid leaks in the hydraulic release system. Any leakage of fluid is unacceptable. See troubleshooting section to determine the course of action.
11. Check the fluid level in the master cylinder on the cyclic. The master cylinder features a transparent lid through which the fluid level can be checked. Hydraulic fluid level must be within the "MIN-MAX" circle on the baffle plate (reference Figure 12.1.1).
12. Check one of the hydraulic release systems for air by pulling one of the levers firmly until it bottoms out. Check the push rod position (reference Figure 12.2.7). If some of the green ring on the push rod is visible, the system is adequately bled. If some of the green on the push rod is NOT visible with the lever completely pulled, the system has too much air in it and must be bled, see Section 12.2 for bleeding instructions.

Repeat with the other lever to check the other cargo hook's hydraulic release system.

13. Visually inspect the load weigh indicator (if optional load weigh system is installed) for damage and security.

## 5.2 5 Year/1000 Hour Inspection

**Every 5 years or 1000 hours of external load operations, whichever comes first, remove the external load bearing components of the dual cargo hook system from the helicopter, disassemble, and inspect the parts per the following instructions.**

For numbers in ( ) refer to Figure 5.2.1. For parts not numbered in the primary cargo hook installation; these are the same P/N's as used in the secondary cargo hook installation. Bushings do not need to be removed unless they are being replaced.

1. Disconnect the electrical release harness connectors and remove slave cylinder/plumbing assembly (see section 25.16 for removal instructions) from the cargo hooks.
2. Remove the cotter pin (18) from the nut (17) and remove nut and washers (15 and 16) from the end of the attach bolt (14).
3. Remove the attach bolt, separating it and the respective cargo hook from the secondary Pivot Link Assembly (9, 10, 11) or the primary Pivot Link Assembly (10, 11, 21).
4. Remove the four attach point bolts (7, 21) and washers (7) securing each pillow block (1, 20) to the hardpoints to remove the remaining components from the helicopter.
5. Separate the Pivot Link Assembly from the Pillow Block (1) by removing cotter pin (5), nut (4), washer (3), and bolt (2).

**Figure 5.2.1 Cargo Hook Installation Components/Disassembly**

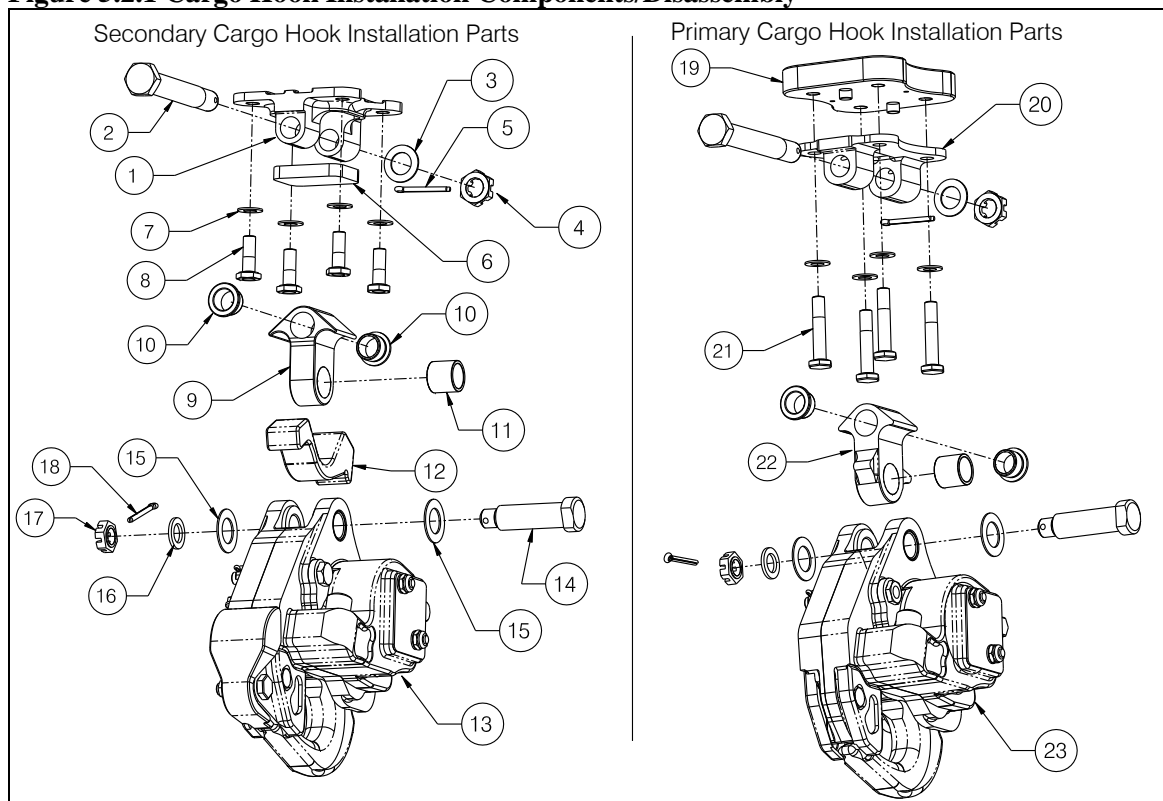

**5.2 5 Year/1000 Hour Inspection** continued

**Table 5.2.1 Cargo Hook Installation Parts**

<b>Item</b>	<b>Part No.</b>	<b>Description</b>	<b>Qty</b>
1	292-019-00	Pillow Block	1
2	510-142-00	Bolt	2
3	510-109-00	Washer	2
4	510-108-00	Nut	2
5	510-222-00	Cotter Pin	2
6	220-047-00	Bumper	1
7	510-100-00	Washer	8
8	511-034-00	Bolt	4
9	292-020-00	Pivot Link	1
10	291-486-00	Flanged Bushing	4
11	290-364-00	Bushing	2
12	290-360-01	Bumper	1
13	232-803-00	Cargo Hook w/ Slave Cylinder	1
	232-803-01	Cargo Hook w/ Slave Cylinder (for the 600N)	
14**	290-332-00	Attach Bolt	2
15	510-183-00	Washer	4
16	510-174-00	Washer	2
17	510-170-00	Nut	2
18	510-178-00	Cotter Pin	2
19	232-456-00	Spacer Assembly	1
20	291-483-00	Pillow Block	1
21	510-308-00	Bolt	4
22	291-484-01*	Pivot Link	1
23	232-809-00	Cargo Hook/Slave Cylinder	1
	232-809-01	Cargo Hook/Slave Cylinder (for the 600N)	

\*Supersedes P/N 291-484-00.

\*\*Replaced by Pin Load Cell (P/N 210-301-03 or P/N 210-226-03 for the 369/500 or P/N 210-301-05 for the 600N) at the primary cargo hook if load weigh system is installed. Washer (15) under Attach Bolt head is also not used with Pin Load Cell.

6. Carefully inspect detail parts in accordance with the instructions in Table 5.2.2. Inspect the parts in a clean, well-lighted room using standard dimensional measuring tools and visual methods. Repair parts found within inspection limits. Replace any part found beyond limits.
7. If the load weigh system is installed, return the Pin Load Cell Assembly to the factory for inspection and calibration. The factory will inspect the condition of the pin load cell and perform acceptance test procedures including calibration and zero balance, repairing as necessary.
8. In addition, remove the bleed screw (refer to Figure 12.2.4) at each cargo hook slave cylinder to drain the hydraulic release system\*\*\*. Re-fill and bleed per the instructions in Section 12.2.

\*\*\*Calendar time alone can be used for replacing hydraulic fluid.

**5.2 5 Year/1000 Hour Inspection** continued

**Table 5.2.2 Dual Cargo Hook System Inspection Criteria**

<b>Seq.</b>	<b>Component</b>	<b>Inspection Criteria and Limit</b>	<b>Repair Action</b>	<b>Finish</b>
1.	Pillow Block (1) Pivot Link (9) Pillow Block (20) Pivot Link (22)	Nicks, dents, scratches, corrosion – 0.010 in. (0.254 mm) deep	Blend at 10:1 ratio as required to provide smooth transitions. Glass bead blast at less than 30 PSI (2.11 KGF/CM <sup>2</sup> ) to remove corrosion.	Passivate per AMS-QQ-P-35 or ASTM A967.
		Any indication of cracks.	None.	N/A
2.	Bolt (2)	Wear on OD – 0.428 in. (10.87 mm)	None.	N/A
3.	Flanged Bushing (10)	Wear on ID – 0.450 in. (11.43 mm)	None.	N/A
4.	Bushing (11)	Wear on ID – 0.520 in. (13.21 mm)	None.	N/A
5.	Attach Bolt (14)	Wear on OD – 0.495 in. (12.57 mm)	None.	N/A
6.	Spacer Assembly (19)	Dents, nicks, cracks, gouges, scratches and corrosion – 0.020 in. (0.50 mm) deep	Blend at 10:1 ratio as required to provide smooth transitions.	Apply Alodine (MIL-DTL-5541) and zinc chromate primer (MIL-PRF- 23377 or similar) to affected surfaces.
7.	Bumper (6)	Denting, cuts or abrasions – 0.060 in. (1.27 mm) deep	None.	N/A
8.	Bumper (12)	Denting, cuts or abrasions – 0.060 in. (1.27 mm) deep	None.	N/A
9.	Cargo Hook (13, 23)	Refer to CMM 122-015-00 for inspection and overhaul instructions for the cargo hook.		
10.	Remaining bolts, nuts, washers, cotter pins.	Wear, corrosion, or deterioration.	None.	N/A

### 5.3 Long Line Kit Inspection

Inspection of the long line kit includes a check before each use (not a maintenance activity) and an annual inspection. Refer also to the manufacturer's Long Line User Manual. All of the manufacturer's inspection requirements must be observed.

The following figure shows the components of the long line kit P/N 200-449-XX. The Y-rope Assembly (item 24, 24.1) interfaces with the dual cargo hooks and is the only required component, for items connected below the Y-rope, locally approved alternate configurations may be used. If an alternate configuration is used refer to its maintenance documentation.

**Figure 5.3.1 Long Line Kit Components**

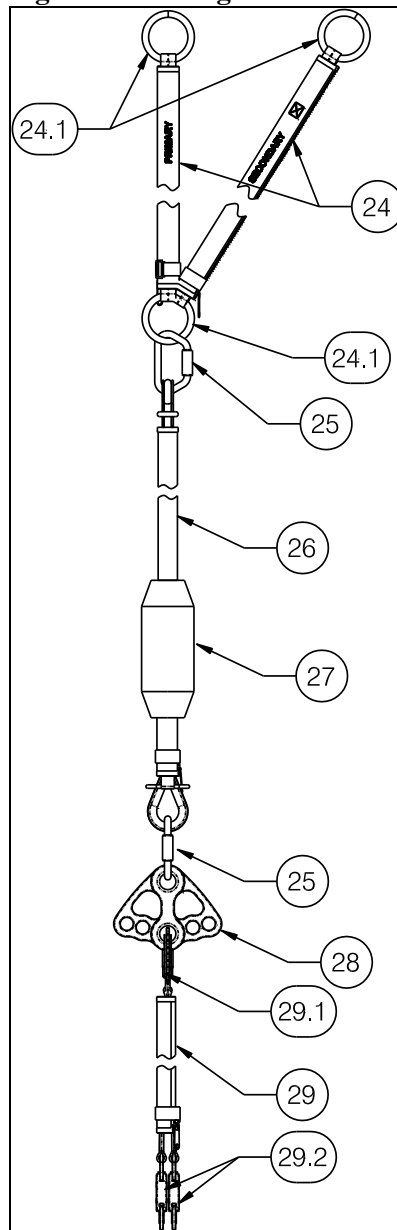

**5.3 Long Line Kit Inspection** continued

**Table 5.3.1 Long Line Kit Parts**

<b>Item</b>	<b>Part No.</b>	<b>Description</b>	<b>Qty</b>
24	490-014-00	Y-rope Assembly	1
24.1	N/A**	Load Ring	3
25	530-031-00	Carabiner	2
26	490-015-XX*	Long Line	1
27	490-017-00	Weight Bag	1
28	292-017-00	Rigging Plate	1
29	490-018-00	Lanyard	1
29.1	N/A**	Carabiner	1
29.2	N/A**	Snap Hook	2

\*Long Line P/N is completed by replacing the “XX” with the length divided by 10, for example a 100 foot long line is P/N 490-015-10 and a 150 foot long line is P/N 490-015-15, etc.

\*\*The Load Rings (24.1), Carabiner (29.1) and Snap Hooks (29.2) are integral to the Y-rope Assembly and Lanyard respectively.

### 5.3 Long Line Kit Inspection continued

---

---

**Prior to a flight involving external load operations that includes use of the long line kit check the condition of the equipment and check the condition of the equipment after each use.**

---

---

Use the criteria defined in the annual inspection as a guide for the check. Also, consult the Long Line User's Manual provided by the rope and manufacturer.

---

---

**Annually inspect the long line kit components per the following.**

---

---

Inspection of the Y-rope, Long Line Assembly, and Lanyard Assembly must be conducted by a qualified person. In addition to the instructions below, consult the Long Line User's Manual provided by the rope manufacturer.

**Inspect the Y-rope Assembly (24) per the following.**

1. Open the covers and inspect them on the inside and outside per the following.
  - Loose, cut or pulled zipper stitching.
  - Loose, cut or pulled stitching of cover to webbing.
  - Torn, cut or otherwise damaged cover material.
  - Legibility of "PRIMARY" and "SECONDARY" markings.
  - Condition and function of zipper.
  - Condition and function of hook and loop closure strap.
2. Inspect the internal webbing material of the Y-rope Assembly per the following.
  - Legibility and security of ID tag.
  - Acid or caustic burns.
  - Holes, tears, cuts or snags.
  - Broken or worn stitching in the load bearing splices.
  - Excessive abrasive wear.
  - Knots in any part of the sling.
  - Discoloration and brittle or stiff areas on any part of the sling.
  - Wear on Load Ring, inspect per criteria in Table 5.3.2.

### **5.3 Long Line Kit Inspection** continued

**Inspect the Long Line Assembly (26) per the following.**

Lay out the long line on a clean surface as it should be thoroughly inspected both visually and by feel over its entire length.

1. Unzip the cover and inspect it inside and outside per the following.
  - Loose, cut or pulled zipper stitching
  - Torn, cut or otherwise damaged loops (attaching each end of cover to thimbles).
  - Torn, cut or otherwise damaged cover material.
  - Condition and function of zipper.
  - Condition and function of hook and loop closure strap.
2. Inspect the rope and end terminations of the Long Line Assembly for the following.
  - Security of thimble, verify it is securely captured by the eye splice.
  - Condition of thimbles, inspect for signs of damage including corrosion, cracks, distortion, nicks, or rough surfaces.
  - Condition of the rope's lockstitch thread and whipping thread at each eye splice, inspect for broken, cut or frayed threads.
  - Legibility and security of ID tag.

Along the entire length of the rope, inspect for the following.

- Externally observed abrasion, cut strands or areas of extensive fiber breakage.
- Fiber breakage, fused or melted fibers observed internally (observed by prying or twisting to open the strands). Remove from service if an estimated 10% of fiber in any strand or the rope as a hole is damaged.
- Uniform fiber breakage along the length of rope such that the entire rope appears covered with fuzz or whiskers.
- Consistent diameter of the rope. Measure the rope diameter in several locations and inspect for flat areas, bumps, or lumps. Remove from service if the diameter has been reduced by more than 10% in any area.
- Discoloration, brittle fibers and hard or stiff areas that may indicate chemical, ultraviolet or heat damage.
- Melted, hard or charred areas which may be evidence of excessive heat. Remove from service if areas in this condition affect more than 10% of the rope diameter or affect several adjacent strands along the length that affect more than 10% of strand diameters.
- Cleanliness of the rope, stiffness of the rope may indicate dirt or grit embedded within its fibers.



### **5.3 Long Line Kit Inspection** continued

**Inspect the Lanyard Assembly (P/N 490-018-00) per the following.**

1. Unzip the cover and inspect the inside and outside per the following.
  - Loose, cut or pulled zipper stitching
  - Loose, cut or pulled stitching of cover to webbing.
  - Torn, cut or otherwise damaged cover material.
  - Condition and function of zipper.
  - Condition and function of hook and loop closure strap.
2. Inspect the load carrying webbing material of the Lanyard Assembly for the following.
  - Legibility and security of ID tag.
  - Acid or caustic burns.
  - Holes, tears, cuts or snags.
  - Broken or worn stitching in the load bearing splices.
  - Excessive abrasive wear.
  - Knots in any part of the sling.
  - Discoloration and brittle or stiff areas on any part of the sling.
3. Inspect the captive carabiner and the two snap hooks of the Lanyard Assembly per Table 5.3.2.

### 5.3 Long Line Kit Inspection continued

Carefully inspect detail parts in accordance with the instructions in Table 5.3.2. Inspect the parts in a clean, well-lighted room using standard dimensional measuring tools and visual methods. Repair parts found within inspection limits. Replace any part found beyond limits.

**Table 5.3.2 Long Line Kit Inspection Criteria – Metallic Components**

<b>Seq.</b>	<b>Component</b>	<b>Inspection Criteria and Limit</b>	<b>Repair Action</b>	<b>Finish</b>
1.	Load Ring (24.1, integral to Y-rope Assembly)	Wear on inside of ring – minimum thickness of cross section of ring - 0.50 in. (12.7 mm)	Blend at 10:1 ratio as required to provide smooth transitions.	N/A
2.	Carabiner (25)	Nicks, dents, scratches, corrosion – 0.020 in. (0.127 mm) deep	Blend at 10:1 ratio as required to provide smooth transitions.	N/A
		Proper engagement of latching mechanism, 3-stage opening action should be free of any binding that may be an indication of deformation.	None.	N/A
3.	Rigging Plate (28)	Nicks, dents, scratches, corrosion – 0.020 in. (0.127 mm) deep	Glass bead blast at less than 30 PSI (2.11 KGF/CM <sup>2</sup> ) to remove corrosion.	Passivate per AMS-QQ-P-35 or ASTM A967
		Wear on inside diameter of holes for attachment to long line and loads. – See Figure 5.3.2	None.	N/A
4.	Carabiner (29.1, integral to Lanyard)	Nicks, dents, scratches, corrosion – 0.020 in. (0.127 mm) deep	Blend at 10:1 ratio as required to provide smooth transitions.	N/A
		Proper engagement and operation of latching mechanism, 3-stage opening action should be free of any binding that may be an indication of deformation.	None.	N/A
5.	Snap Hook (29.2, integral to Lanyard)	Nicks, dents, scratches, corrosion – 0.020 in. (0.127 mm) deep	Blend at 10:1 ratio as required to provide smooth transitions.	N/A
		Proper engagement and operation of gate mechanism, 2-stage opening action should be free of any binding that may be an indication of deformation.	None.	N/A

5.3 Long Line Kit Inspection continued

Figure 5.3.2 Rigging Plate Inspection Criteria

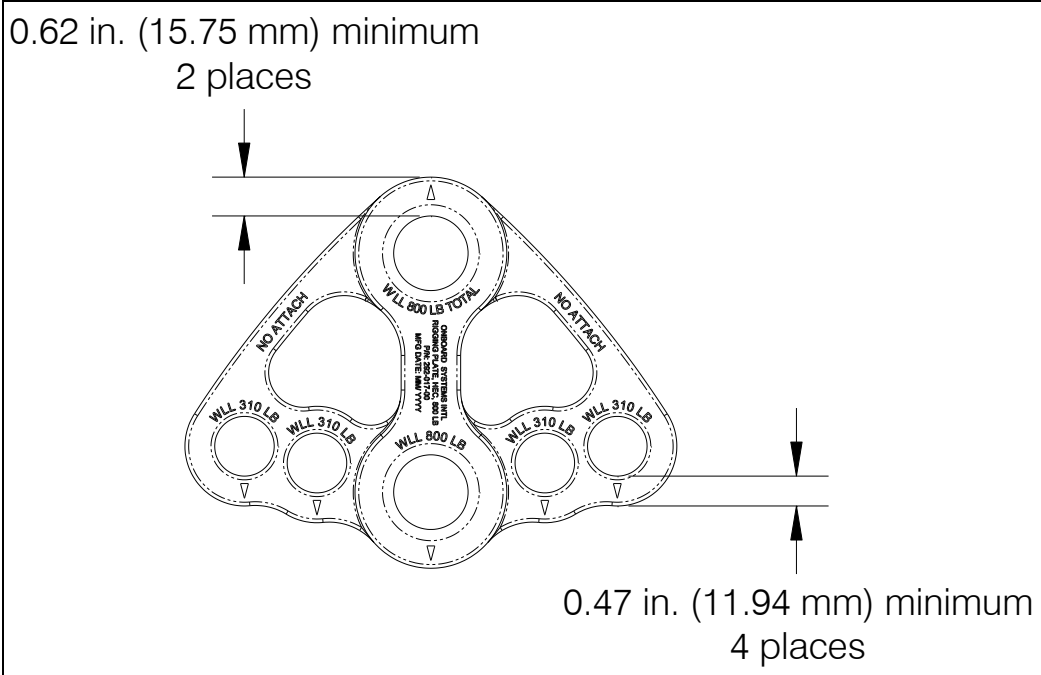

## 5.4 Cargo Hook Overhaul Schedule

Time Between Overhaul (TBO): 1000 hours of external load operations or 5 years, whichever comes first.

# NOTICE

*Hours of external load operations should be interpreted to be (1) anything is attached to the cargo hook (whether or not a useful load is being transported) and (2) the aircraft is flying. If these conditions are **NOT** met, time does **NOT** need to be tracked.*

Overhaul the cargo hooks per CMM 122-015-00. Contact Onboard Systems for guidance to locate authorized overhaul facilities.



# Section 11

## Placards and Markings

### 11.1 Placards



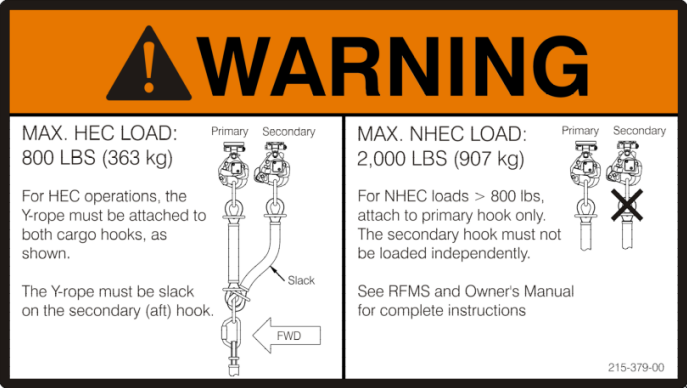
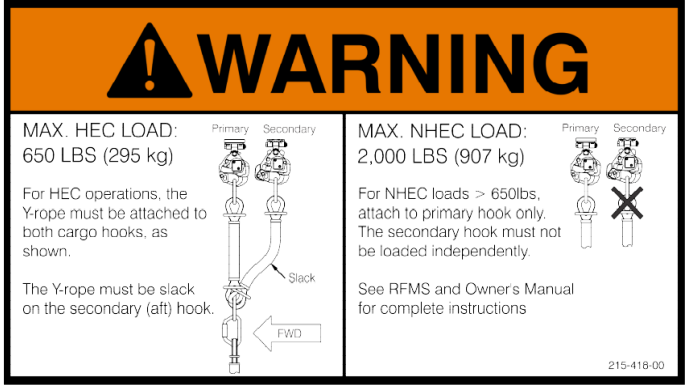

The Dual Cargo Hook System includes the following placards shown in Table 11.1.

**Table 11.1 Dual Cargo Hook System Placards**

Placard part number and appearance	Location
<p>Placard P/N 215-379-00 (applicable to 369 series/500N)</p>  <p><b>WARNING</b></p> <p><b>MAX. HEC LOAD:</b> 800 LBS (363 kg)</p> <p>For HEC operations, the Y-rope must be attached to both cargo hooks, as shown.</p> <p>The Y-rope must be slack on the secondary (aft) hook.</p> <p><b>MAX. NHEC LOAD:</b> 2,000 LBS (907 kg)</p> <p>For NHEC loads &gt; 800 lbs, attach to primary hook only. The secondary hook must not be loaded independently.</p> <p>See RFMS and Owner's Manual for complete instructions</p> <p>215-379-00</p>	<p>Installed on the belly of the helicopter, adjacent to the cargo hooks.</p>
<p>Placard P/N 215-418-00 (applicable to 600N)</p>  <p><b>WARNING</b></p> <p><b>MAX. HEC LOAD:</b> 650 LBS (295 kg)</p> <p>For HEC operations, the Y-rope must be attached to both cargo hooks, as shown.</p> <p>The Y-rope must be slack on the secondary (aft) hook.</p> <p><b>MAX. NHEC LOAD:</b> 2,000 LBS (907 kg)</p> <p>For NHEC loads &gt; 650lbs, attach to primary hook only. The secondary hook must not be loaded independently.</p> <p>See RFMS and Owner's Manual for complete instructions</p> <p>215-418-00</p>	
<p>Placard P/N 215-377-00</p>  <p><b>PRIMARY HOOK RELEASE</b></p>	<p>Installed on the release lever on the cyclic for the primary cargo hook.</p>
<p>Placard P/N 215-377-00</p>  <p><b>SECONDARY HOOK RELEASE</b></p>	<p>Installed on the release lever on the cyclic for the secondary cargo hook.</p>

continued

Table 11.1 Dual Cargo Hook System Placards continued

Placard part number and appearance	Location
Placard P/N 215-377-00 	Installed adjacent to the pushbutton switch integrated into the release lever on the cyclic for the secondary cargo hook.
Placard P/N 215-381-00 	Installed adjacent to the circuit breaker for the secondary cargo hook.
Placard P/N 215-417-00 	Installed adjacent to the circuit breaker for the load weigh system (if installed).
Placard P/N 215-382-00 	Located on the belly of the helicopter adjacent to the hydraulic hose connection for the primary cargo hook.
Placard P/N 215-382-00 	Located on the belly of the helicopter adjacent to the hydraulic hose connection for the secondary cargo hook.

## Section 12

# Servicing

### 12.1 Maintenance of the Hydraulic Release System

The system is filled with fluid at installation and does not consume fluid unless it leaks out. If any leakage is detected, the fluid level should be immediately checked.

To check the fluid level:

1. Position the cyclic such that the reservoir is level.
2. The Dual Master Cylinder features a transparent lid through which the fluid level can be checked. Hydraulic fluid level must be within the MIN/MAX circle on the baffle surface (see Figure 12.1).
3. If necessary, remove lid and add hydraulic fluid as required (MIL-PRF-87257 hydraulic fluid is supplied with the system and is recommended, MIL-PRF-5606 fluid is also compatible). When re-installing lid do not over-tighten screws.

**Figure 12.1.1 Checking Hydraulic Fluid Level**

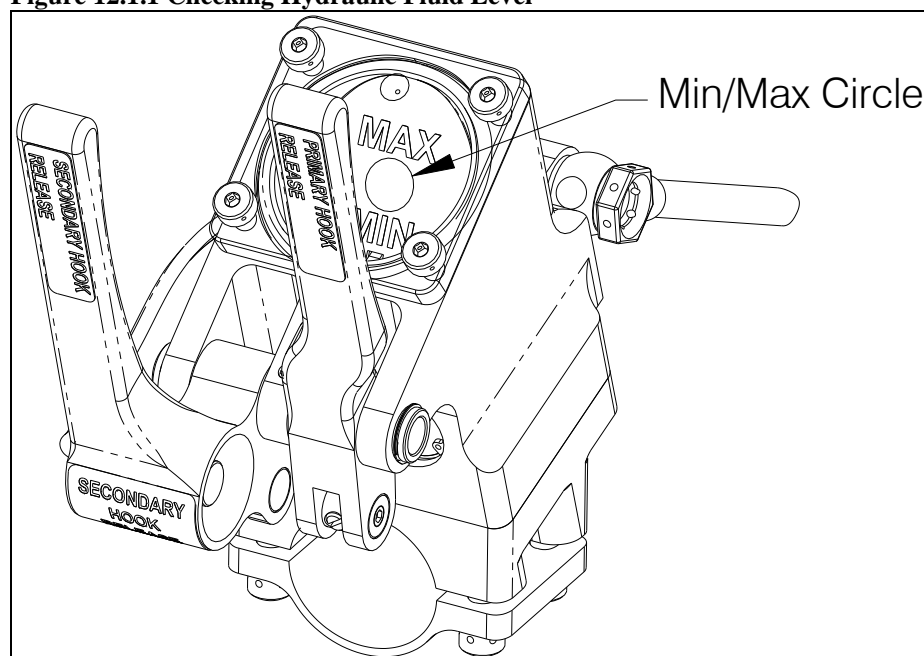

If leakage is noted around any plumbing fittings, the fittings may be tightened until the leakage quits. If leakage is noted around the pistons in either the master or slave cylinders the leaking cylinder must be repaired. See the instructions for repair in this section.

## 12.1 Maintenance of the Hydraulic Release System, continued

### Master Cylinder Repair

If fluid is leaking around the piston, the only repair is to remove and replace the cup seal and O-ring. The master cylinder must be disassembled, inspected and then re-assembled with new seals.

#### Disassembly:

1. Remove snap ring. Use caution when removing snap ring since the piston is spring loaded against the washer and snap ring. The piston will pop out of the housing when the snap ring is removed. Use the lever to put pressure on the piston while removing snap ring.
2. Loosen the set screw and disconnect barrel nut on lever. See Figure 12.1.2.
3. Remove the piston and spring. See Figure 12.1.3 for parts breakdown.
4. Inspect the master cylinder bore for scratches. If any scratches or gouges are visible in the bore, the master cylinder must be replaced.

#### Re-assembly

1. If the bore condition is acceptable, replace the cup seal and O-ring on the piston assembly. Orient the cup seal as shown in Figure 12.1.4. Stretch seals over piston into grooves.
2. Lubricate the piston seals and cylinder bore generously with hydraulic fluid.
3. Place the spring in the cylinder bore.
4. Pass the push rod through the washer.
5. Thread the push rod into the barrel nut until approximately 1/16" of thread is visible through the opposite side of the barrel nut.
6. Insert the small spring into the piston assembly and insert the piston assembly into the master cylinder bore using a firm rocking motion.
7. Use the lever to compress the spring and hold the piston in place.
8. Use snap ring pliers to install the snap ring.
9. Secure push rod threads by tightening set screw.

Figure 12.1.2 Master Cylinder Lever Disconnect

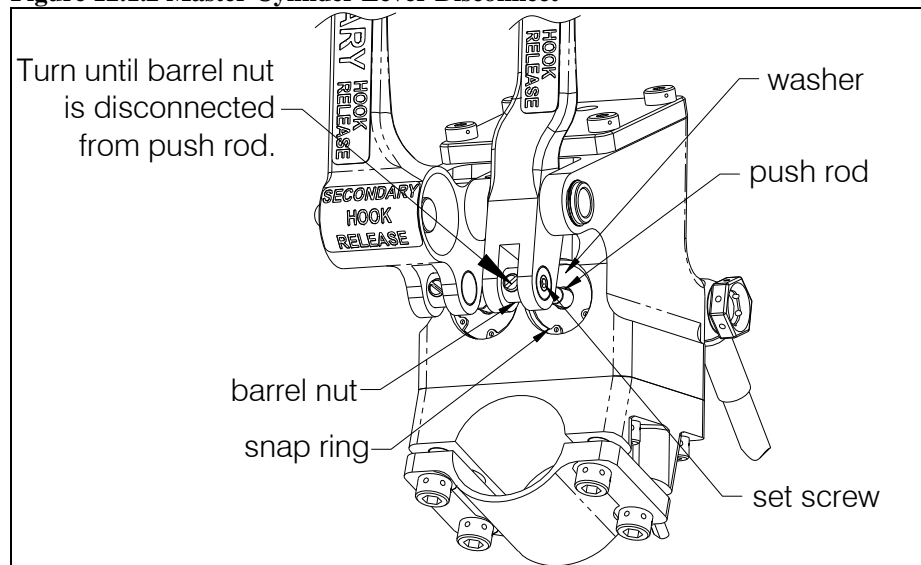



## 12.1 Maintenance of the Hydraulic Release System, continued

### Master Cylinder Repair continued

Figure 12.1.3 Master Cylinder Piston Removal

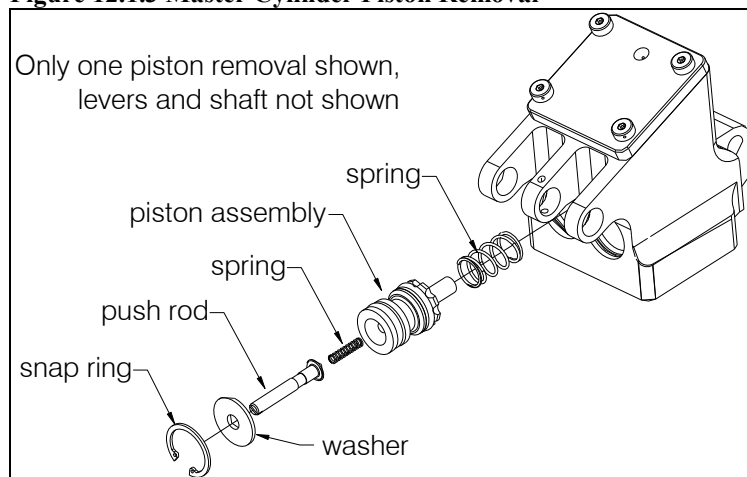
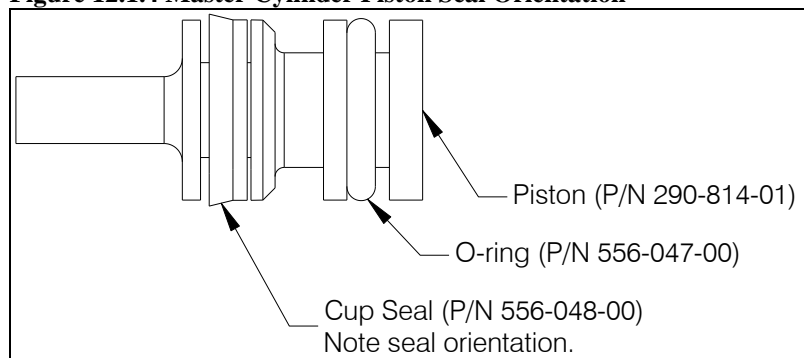

Figure 12.1.4 Master Cylinder Piston Seal Orientation



### Slave Cylinder Repair

If the slave cylinder is leaking fluid around the piston rod, the only repair possible is to remove and replace the quad ring.

#### Disassembly:

1. Remove cap, piston, and seal (see Figure 12.1.5).
2. Inspect bore of slave cylinder for scratches or gouges. If any are present the assembly must be replaced.
3. Remove bushing in cap by pressing it out.
4. Remove quad ring by stretching it over the piston.

#### Re-assembly:

1. Press new bushing into cap.
2. Stretch new quad ring over piston into groove.
3. Clean and lubricate cylinder bore and piston seal with hydraulic fluid.
4. Insert piston into cylinder taking care not to damage edges of quad ring.
5. Screw on cap and torque to 50-60 in-lbs.

# 12.1 Maintenance of the Hydraulic Release System, continued

## Slave Cylinder Repair continued

Figure 12.1.5 Slave Cylinder Piston Removal

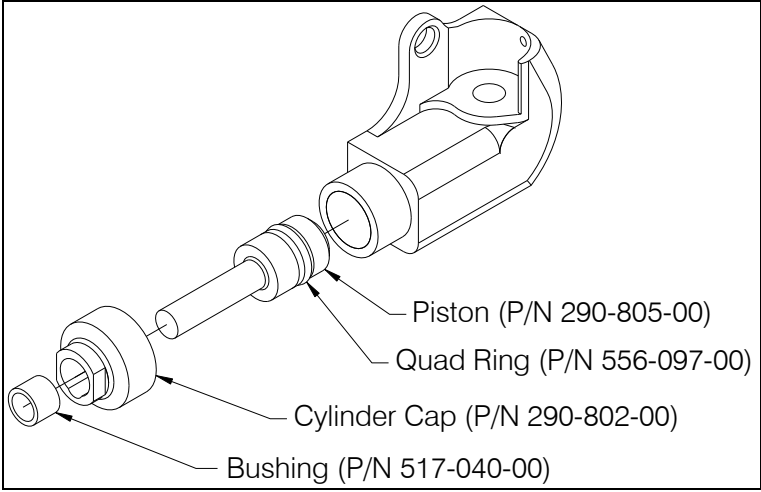

## 12.2 Bleeding Hydraulic System

Filling and bleeding requires two persons, one to inject hydraulic fluid through the system and the other to observe the reservoir. Following is the procedure.

Bleeding procedure:

1. Obtain the hydraulic hook bleed kit, 212-014-02. This kit consists of 2 ounces of MIL-PRF-87257 fluid, a syringe, a female barb fitting, a length of PVC tubing, and a bleed adapter fitting. The bleed kit is included in new hook kits. Assemble the bleed kit by press fitting each component as shown.

**Figure 12.2.1 Hydraulic Hook Bleed Kit**

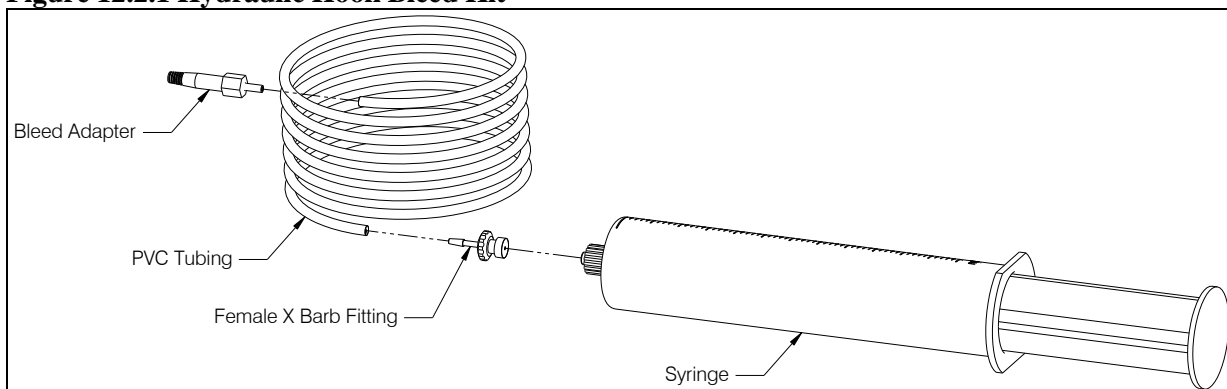

2. Place an absorbent towel under the master cylinder.

**NOTICE**

*Use best shop practices to keep foreign material out of the hydraulic system. FOD will plug orifices, damage seals and/or scratch sealing surfaces necessitating system rebuild. Use only clean hydraulic fluid from sealed containers.*

## 12.2 Bleeding Hydraulic System, continued

3. Connect each slave cylinder assembly plumbing to the respective master cylinder assembly plumbing if not already done.
4. Remove screws, reservoir lid, and baffle from the master cylinder reservoir as shown in Figure 12.2.3.

**Figure 12.2.3 Reservoir Disassembly**

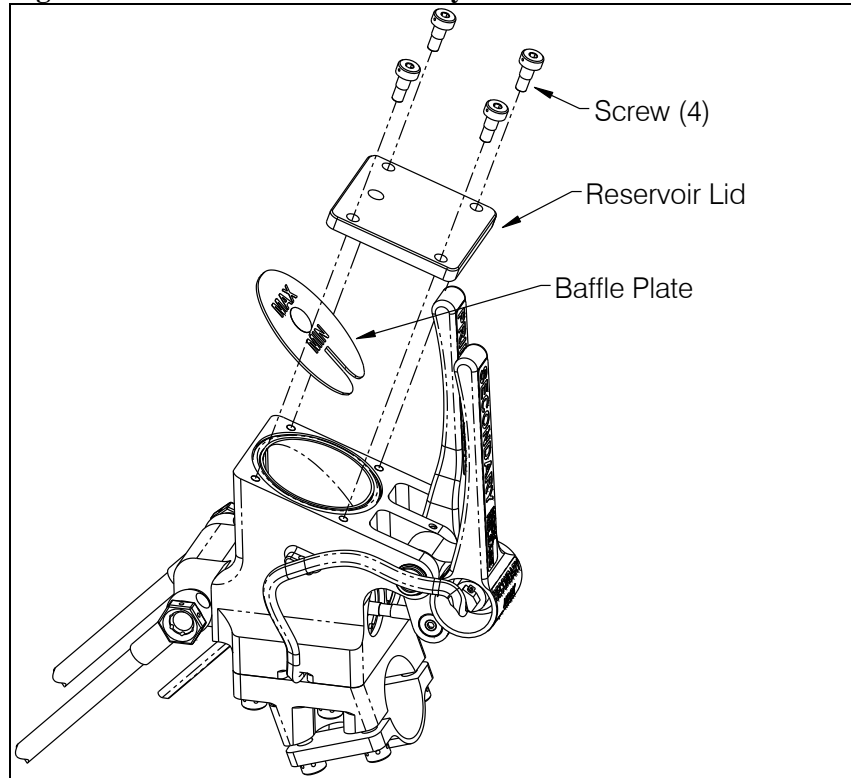

## 12.2 Bleeding Hydraulic System, continued

5. Remove the screw, two washers, and thread seal washer from either cargo hook slave cylinder, see Figure 12.2.4.

**Figure 12.2.4 Screw and Washer Removal**

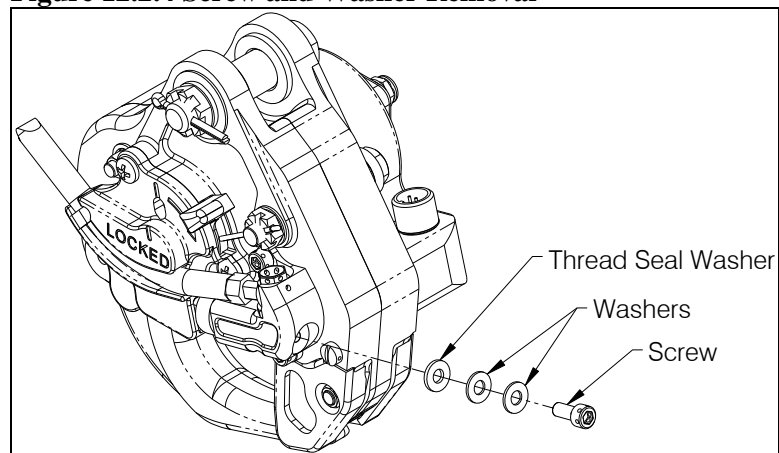

6. Fill the syringe with approximately 35 cc of hydraulic fluid and purge any remaining air in the syringe and tubing. Screw the end of the bleed adapter into the screw hole on the slave cylinder to create a tight seal. See Figure 12.2.5.
7. While observing the reservoir, **slowly** push on the syringe plunger to force fluid through the slave cylinder, hydraulic hose, and up to the master cylinder reservoir. There will be some resistance during filling—this is normal.



*Injecting the fluid into the system too rapidly may cause the fluid to spray up and out of the master cylinder reservoir. Wear safety glasses when observing fluid reservoir while filling.*

**Figure 12.2.5 Injecting Hydraulic Fluid**

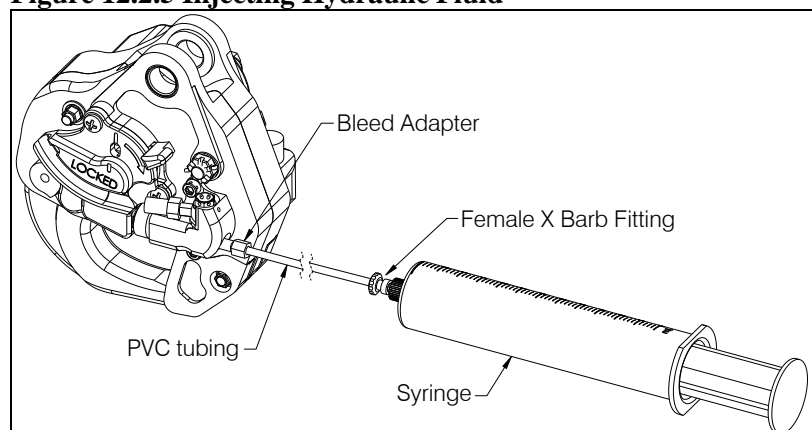

## 12.2 Bleeding Hydraulic System, continued

8. Continue to force fluid into the master cylinder reservoir until the reservoir is about to the top of the divider.



*If bleeding an already filled system, you may need to draw fluid from the master cylinder reservoir during this step to prevent overflow.*

9. Have the washers, thread seal washer, and screw ready to install as fluid will drain from the screw hole when the bleed adapter is removed.
10. Remove the bleed adapter from the screw hole and promptly re-install the washers, thread seal washer, and screw, see Figure 12.2.4.
11. Allow the system to rest for several minutes. This will allow any air to rise through the system.
12. Very **slowly** pull the release lever on the master cylinder and watch for bubbles. If bubbles are observed rising within the reservoir, continue to slowly cycle the lever until there are no more. Actuating the lever releases air trapped within the master cylinder.



*Pull the lever very slowly! When the reservoir is not baffled and capped, a hard pull will cause fluid to erupt over the edge of the reservoir.*

13. Repeat steps 5 – 12 for the other cargo hook.

## 12.2 Bleeding Hydraulic System, continued

14. Check the system for air by actuating the lever firmly until it bottoms out. Check the push rod position (see Figure 12.2.7). If some of the green ring on the push rod is visible, proceed to step 13. If some of the green on the push rod is not visible with the lever completely pulled, the system has too much air in it and needs further bleeding. To do this, repeat steps 5 – 12.
15. After the system is properly bled, verify that the reservoir is approximately half full of hydraulic fluid. Fluid should be visible above the baffle.
16. Re-install the baffle plate and the reservoir lid.
17. Check the system for proper operation. Fully actuate the secondary release lever (left lever), the secondary (aft) cargo hook must open and the lever must have a firm feel. Fully actuate the primary release lever (on the right), the primary (forward) cargo hook must open and the lever must have a firm feel.
18. Disassemble and thoroughly clean the bleed kit with isopropyl alcohol. Allow it to dry. Not cleaning the syringe will render it unusable. Reassemble and store for next use.

**Figure 12.2.7 Checking System for Air**

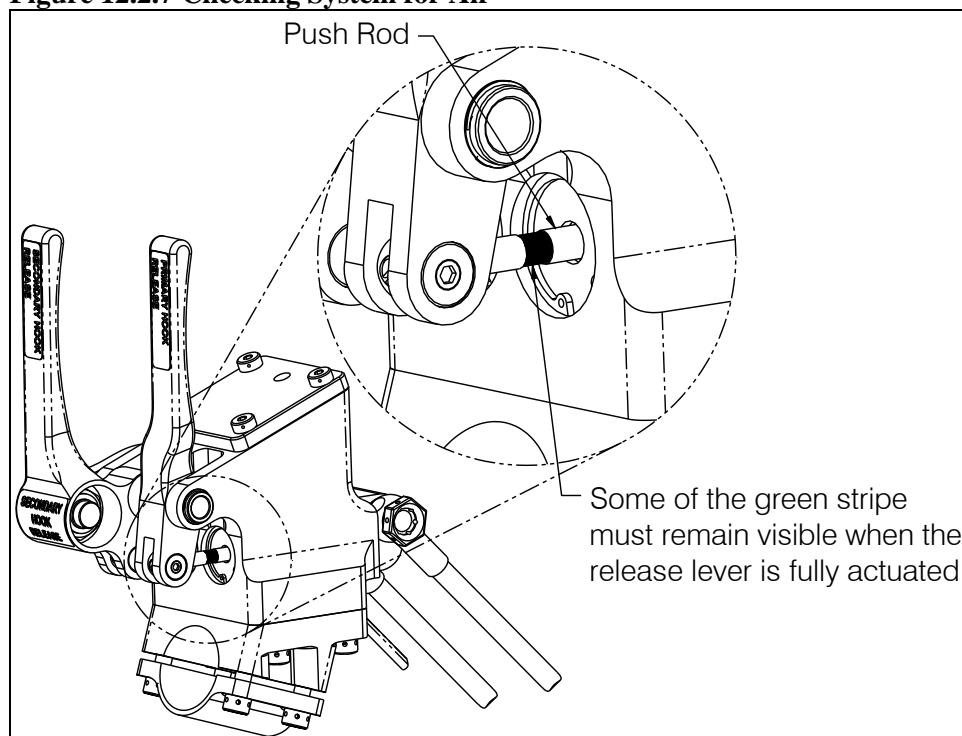

## 12.3 Lubrication Information

Lubrication of Cargo Hook and linkage pivot points is recommended every 500 hours of external load operations.

Lubricate the pivot points illustrated in Figure 12.3.1. Recommended lubricants are AeroShell 7 (MIL-PRF-23827) or Mobilgrease 28 (MIL-PRF-81322).

For re-assembly after lubrication, tighten nuts to finger tight until fully seated then rotate to previous castellation if necessary to install cotter pin.

# CAUTION

*Do not tighten nut on pin load cell (if installed) more than finger tight. Over-tightening will damage load cell.*

**Figure 12.3.1 Lubrication Points (primary cargo hook shown)**

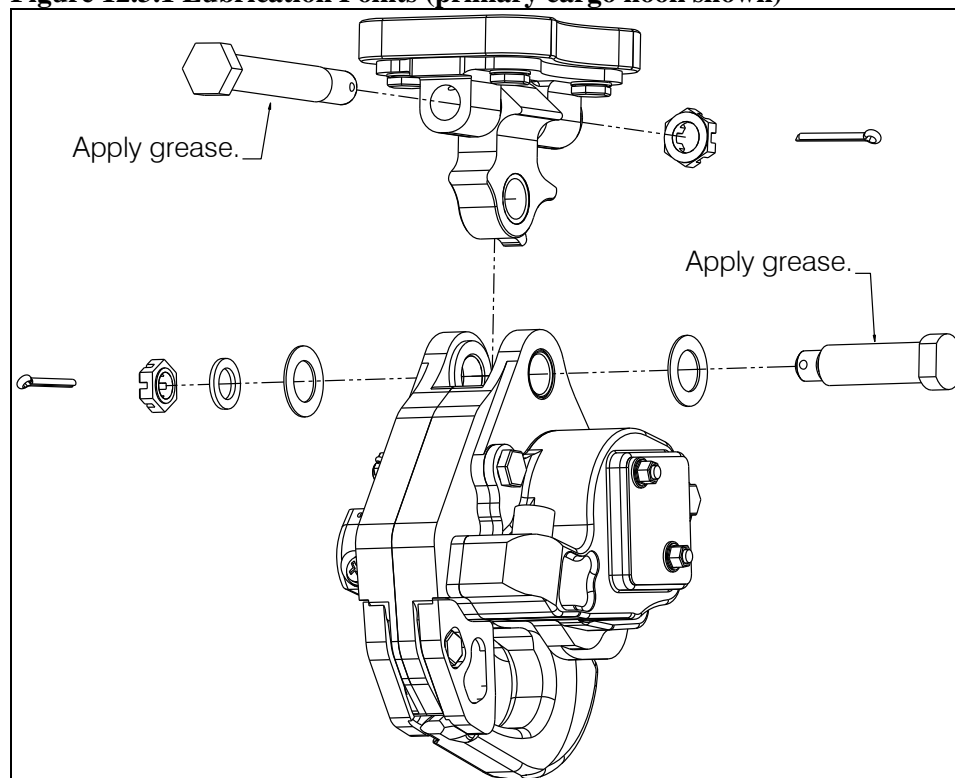



## **12.3 Lubrication Information, continued**

### **Hook Corrosion Prevention**

In marine or other corrosive environments the life of the cargo hook can be increased by periodically treating with a corrosion preventative compound such as ACF-50. Spray exterior of hook with corrosion preventative compound and wipe off excess with a rag.

The amount and frequency of application will vary depending on climate. In dry dusty environments it is not recommended to treat for corrosion since the oily residue on the inside of the cargo hook that cannot be wiped off could attract and retain dust and sand. In addition corrosion is not likely to be a problem in these conditions. For offshore or coastal operations, treatment could be done every two weeks.

THIS PAGE INTENTIONALLY LEFT BLANK

## Section 25 Equipment and Furnishings

### 25.2 Description

The dual cargo hook system is comprised of:

1. Dual cargo hooks to which the supplied Y-rope is attached for carrying of HEC. These cargo hooks are referred to as the primary cargo hook and secondary cargo hook. The Y-rope loads the primary cargo hook with a slack leg attaching to the aft secondary cargo hook. In the event of an inadvertent release from the primary cargo hook, the secondary cargo hook acts as a reserve means of retaining the HEC.

The primary cargo hook attaches to the original MDHI type certified hardpoint on the aircraft which is rated for 2000 lbs and the secondary cargo hook attaches to the secondary hardpoint approved under this STC. The secondary hardpoint is approximately 6 inches aft of the TC hardpoint and is rated for 800 lbs HEC.

Each cargo hook is attached to the respective hardpoint through a structural linkage referred to as an Attach Point Assembly.

**Figure 25.2.1 Dual Cargo Hook Configuration**

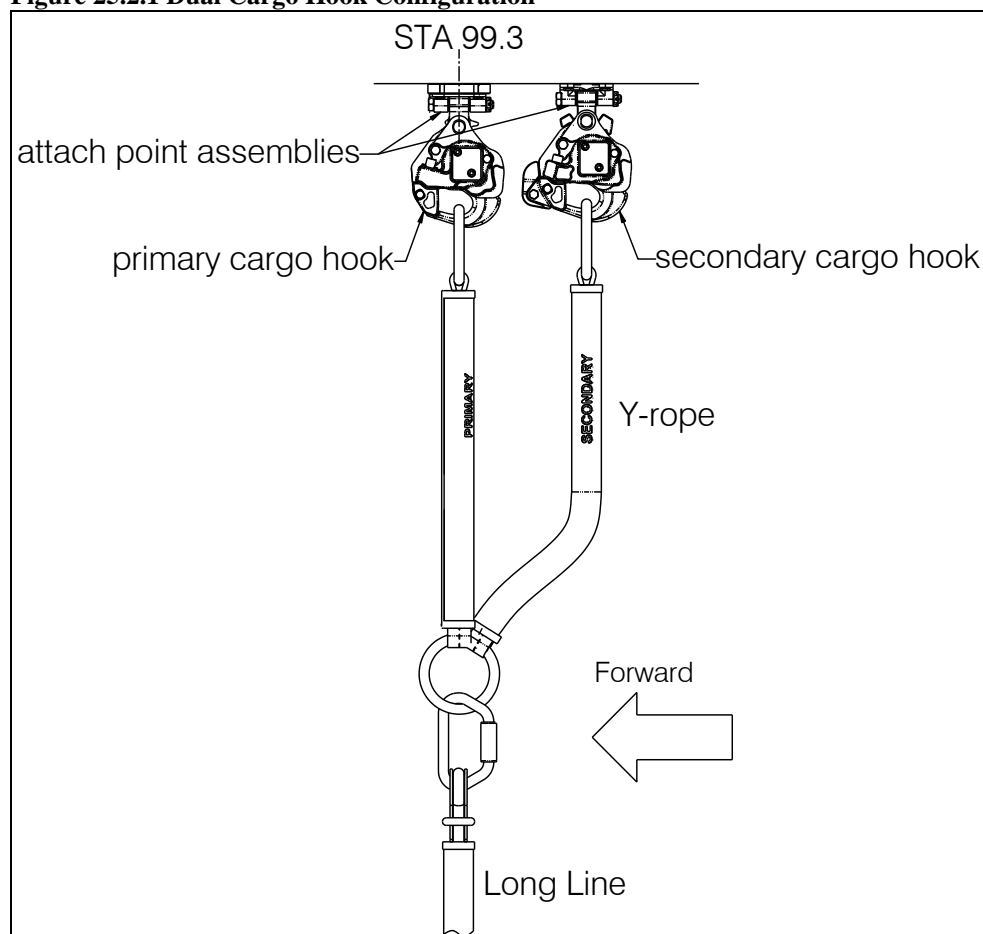

## 25.2 Description continued

2. A primary backup quick release sub-system (PQRS) and a backup quick release sub-system (BQRS) for each cargo hook with the controls for each sub-system located on the cyclic (see Figure 25.2.2). The BQRS release levers are part of the hydraulic release system's Dual Master Cylinder Assembly which is shown in the figure below. The Dual Master Cylinder Assembly is connected to the cargo hooks through independent hose assemblies with disconnects on the belly of the aircraft. Actuating a lever results in fluid forced through the hose to a slave cylinder assembly on the cargo hook which extends a piston to unlatch the cargo hook mechanism and release the load.

The primary cargo hook electrical release system interfaces with the MDHI type certificated cargo hook internal wiring including the switch on the cyclic. An external electrical harness is included with kit P/N 200-448-00 which connects the primary cargo hook connector to the fixed electrical connector mounted in the belly.

A complete primary quick release sub-system (PQRS) is included for the secondary cargo hook. This system is an electrical system with the release switch mounted within the dual master cylinder assembly on the cyclic (see Figure 25.2.2). This system also includes the circuit breaker, a relay located forward of the battery under the pilot's feet, an internal wire harness and an external wire harness with connectors located on the belly of the aircraft.

**Figure 25.2.2 Cargo Hook PQRS and BQRS Controls**

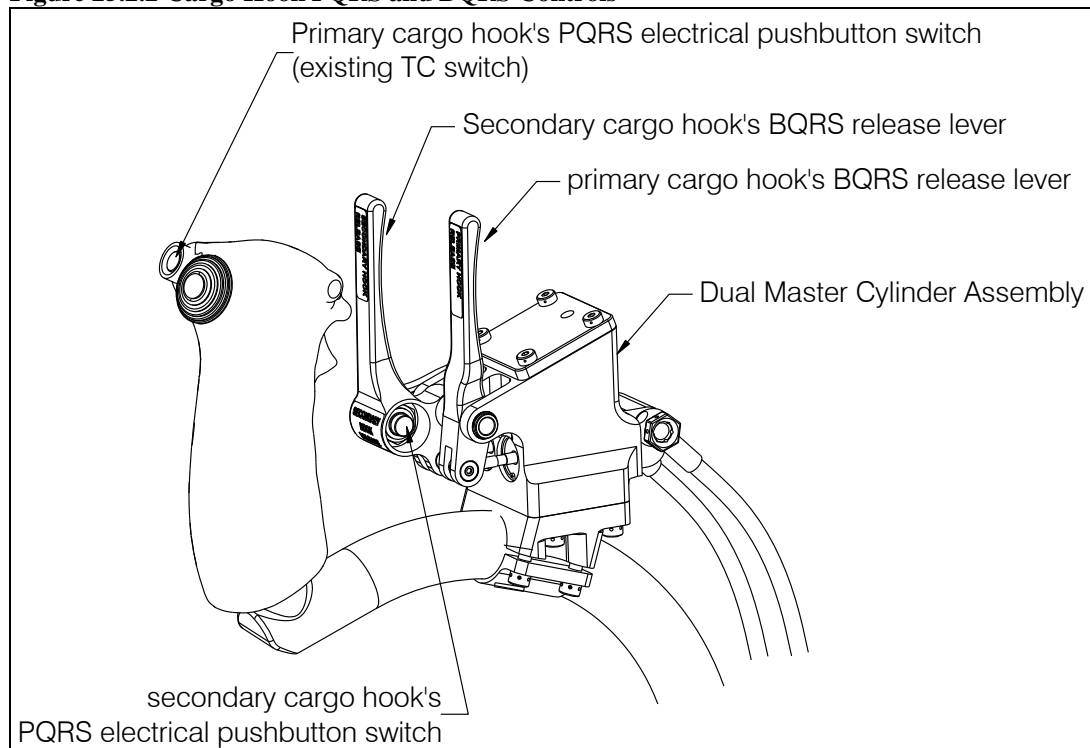

## 25.2 Description continued

3. Structural parts installed under the fuel bladder and one bay aft of the existing MDHI hardpoint fittings installed at station 99.3. These hardpoint fittings provide the mounting holes for the secondary cargo hook attach point assembly and transfer the external loads to the airframe. The cutaway below shows the location and the fittings on the right side of the keel beam.

**Figure 25.2.3 Hardpoint Fittings**

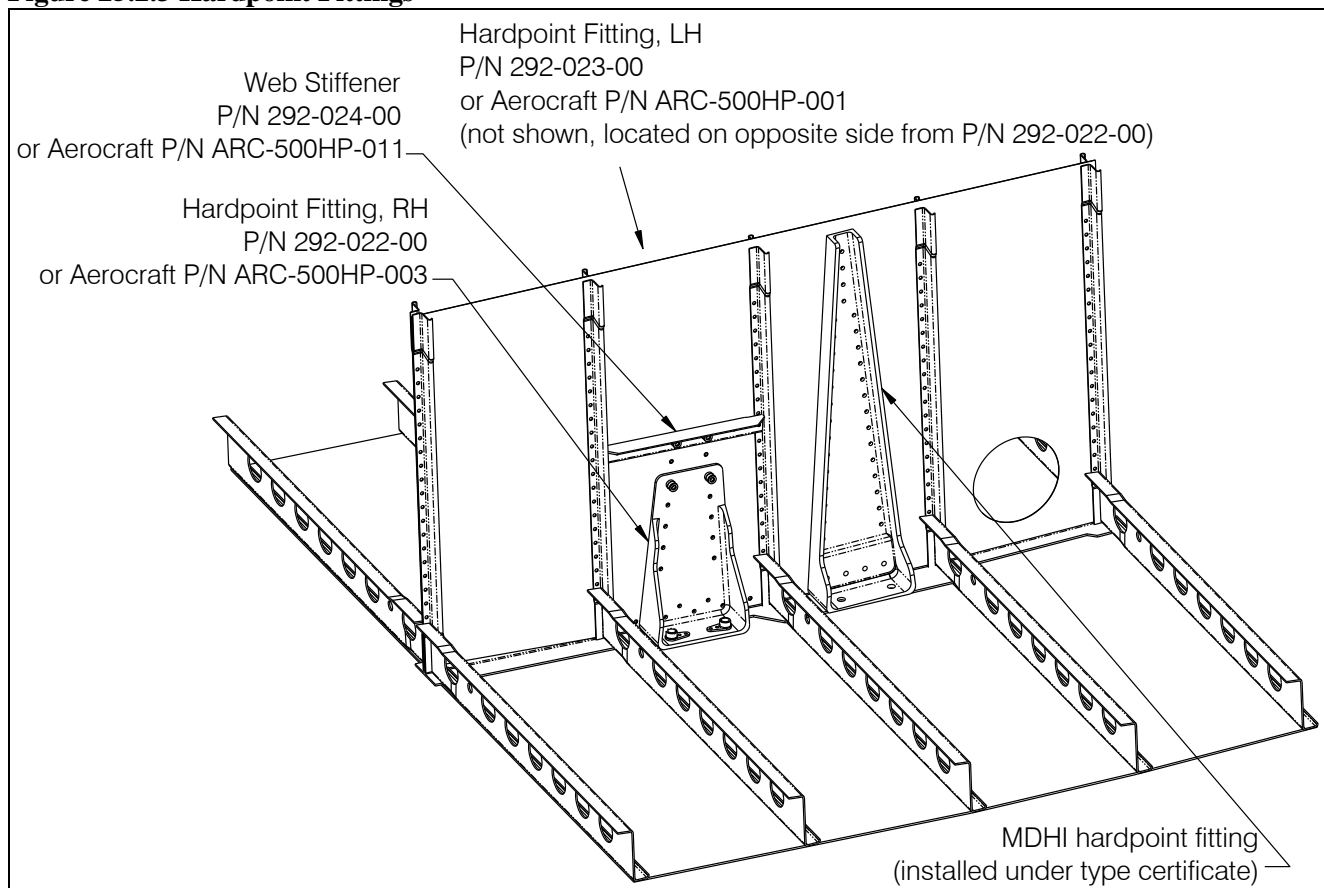

4. The optional load weigh system provides the pilot with the weight of the external load being carried on the cargo hook. It includes a pin load cell, internal electrical harness, and load weigh indicator in the cockpit. When this kit is installed the pin load cell assembly replaces the cargo hook attach bolt at the primary cargo hook.

## 25.5 Component Weights

The weight and cg of the complete system is listed in Table 25.5.1.

**Table 25.5.1 Dual Cargo Hook System Weights and CGs**

P/N	Weight	Long. Arm (in.)	Lat. Arm (in.)
200-448-00 200-448-01	14.2 lbs. (6.4 kg)	94.8	2.3

**Table 25.5.2 Load Weigh System Weights and CGs**

P/N	Weight	Long. Arm (in.)	Lat. Arm (in.)
200-383-00 200-383-01	1.5 lbs (0.68 kg)	*	*

\*Location of Indicator (0.5 lbs) is optional within the cockpit. Pin Load Cell (0.4 lbs) is located at Cargo Hook and replaces the Attach Bolt. Electrical Harness (0.60 lbs) is routed between these items.

The weights of the long line kit components with a 100 foot long line are included in Table 25.5.3. The long line is attached to the primary cargo hook at station 99.3.

**Table 25.5.3 Long Line Kit Weights and CGs**

Item	Weight Lbs. (kg)
Y-rope (P/N 490-014-00)	3.6 (1.63)
Carabiner (P/N 530-031-00) Qty 2	0.7 (0.32)
Rigging Plate (P/N 292-017-00)	1.75 (0.79)
Long Line, 100 ft (P/N 490-015-10)	16.05 (7.28)
Weight Bag (P/N 490-017-00)	27.10 (12.30)
Lanyard (P/N 490-018-00)	3.25 (1.47)
<b>Total Kit Weight</b>	<b>52.5 (23.8)</b>

## 25.12 Storage Instructions

For temporary storage the master cylinder must be stored with the reservoir lid up. The lid contains an air vent that will allow hydraulic fluid to drain out if left inverted. If long term storage or shipping must be done where the orientation of the master cylinder cannot be controlled, either drain the reservoir or place a piece of tape or similar over the air vent to prevent leakage. If draining before storage, remove the hose attached to the master cylinder and drain it as well. Seal the hydraulic parts in a plastic bag to prevent dirt contamination. The slave cylinder needs no special handling.

Refer to CMM 122-015-00 for storage instructions for the Cargo Hook.

Clean and dry the long line kit components (Y-rope, longline, and lanyard assemblies) thoroughly before storage. To clean the rope and web slings use mild soap and water and a sponge, a hard bristle brush may damage the webbing. Alternatively soak the lines in mild soap and water for a short period. After cleaning, rinse thoroughly and completely dry before storing.

Store the Y-rope, long line, and lanyard assemblies in their bags in a cool, dry storage area.

## 25.15 Troubleshooting

Table 25.15.1 is provided with the intention of isolating the cause of malfunctions within the system. Sections 25.16 and 25.17 include instructions for removing and replacing defective components. Refer to the appropriate MD Helicopter maintenance instructions for guidance on procedures relating to parts that interface with these kits.

**Table 25.15.1 Troubleshooting**

MALFUNCTION	PROBABLE CAUSE	CORRECTIVE ACTION
Cargo hook does not operate electrically or manually.	Defective internal mechanism.	Remove and replace cargo hook (see sections 25.16 and 25.17) or repair per CMM 122-015-00.
Cargo hook does not operate electrically, hydraulic release operates normally.	Open electrical circuit, faulty wiring, circuit breaker, relay, switch or solenoid.	Disconnect harness from electrical connector on cargo hook. Using multi-meter, check for 3.0 to 4.0 ohms between pins A and B of electrical connector (see note 1 below). If open indication is obtained, remove and replace cargo hook (see sections 25.16 and 25.17) or repair per CMM 122-015-00.
Cargo hook operates electrically, but not manually.	Leaks in hydraulic hose system. Air in hydraulic hose system. Jammed slave cylinder.	Check for leaks in hydraulic hose system and correct defects if found. Bleed hydraulic system per this manual. Remove slave cylinder from cargo hook and check that the piston extends when the release lever on the cyclic is actuated. Repair cargo hook per CMM 122-015-00.
Load beam fails to re-latch after being reset.	Defective latch mechanism.	Remove and replace cargo hook (see sections 25.16 and 25.17) or repair per CMM 122-015-00.
Force required to release a cargo hook with lever on the cyclic exceeds 14 lbs.	Friction in internal mechanism or defective hydraulic system.	Remove slave cylinder from hook and manually operate master cylinder. If operation feels free and force is less than 5 lbs. Remove and replace cargo hook (see Section 25.16 and 25.17) or repair per CMM 122-015-00.
Hydraulic fluid leaks at hose fittings.	Loose fittings.	Tighten fittings. Check fluid level in reservoir. Bleed hydraulic system per Section 12.2.
Hydraulic fluid leaks around master or slave cylinder pistons.	Leaking seals	Replace master or slave cylinder assembly or repair per Section 12.
Cargo hook fails to open or re-lock properly.	Friction in internal mechanism.	Remove and replace cargo hook (see Sections 25.16 and 25.17) or repair per CMM 122-015-00.
Circuit breaker opens when cargo hook is energized.	Short in the system, faulty wiring, circuit breaker or solenoid.	Refer to MD Helicopter maintenance documentation for internal cargo hook electrical release wiring for the primary cargo hook electrical release. Check for shorts to ground along length of wire harness runs (see note 2). Check solenoid resistance (see note 1), repair or replace defective parts.

**Table 25.15.1 Troubleshooting** continued

MALFUNCTION	PROBABLE CAUSE	CORRECTIVE ACTION
Load Weigh Indicator does not power up.	Faulty wiring or circuit breaker.	Check the circuit breaker and wiring (see note 2). If this doesn't help, remove and replace the indicator per sections 25.16 and 25.17.
The displayed load on the Load Weigh Indicator is incorrect.	Incorrect calibration code.	Ensure the correct calibration code has been entered (refer to the appropriate Owner's Manual for the model of indicator installed).
C-39 model Load Weigh Indicator only: Displayed load is not stable.	Dampening level is too low.	Adjust the dampening level to a higher number (refer to the Owner's Manual for the C-39 indicator for instructions).
C-39 model Load Weigh Indicator only: Indicator displayed load takes too long to change the reading when the load is changed.	Dampening level is too high.	Adjust the dampening level to a lower number (refer to the Owner's Manual for the C-39 indicator for instructions).
Load Weigh Indicator does not change with changing hook loads.	Defective load cell, indicator failure or damaged wire harness.	Check for damaged wire harness, remove and replace wire harness assembly or load cell (see sections 25.16 and 25.17).

**Notes:**

**1. Checking resistance at pins A and B.**

Check for 3.0 to 4.0 ohms between pins A and B of electrical connector located on the cargo hook (see below).

**Figure 25.15.1 Cargo Hook Electrical Connector**

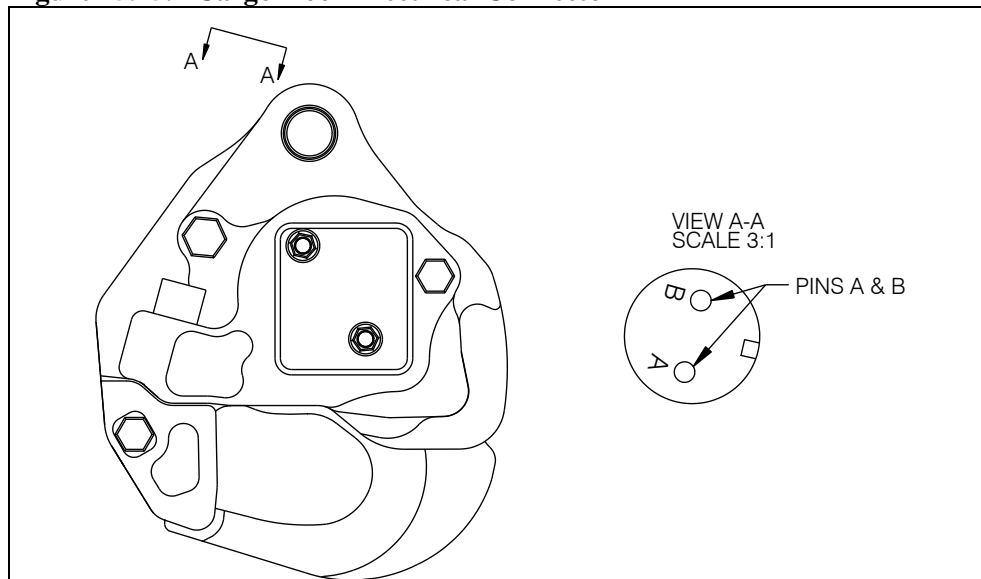



**Table 25.3 Notes continued:**

**2. Checking Wire Harnesses.**

As appropriate, before working on a circuit, e.g. - inspection, removal-installation of components, make sure that power is off.

The external wire harnesses are routed from the cargo hooks to connectors located in the fuselage skin below the pilot seat. The primary cargo hook's electrical release harness from the cargo hook is terminated at the connector located in the original MD Helicopters' doubler in the aircraft belly skin and interfaces with the existing MD Helicopters' internal cargo hook electrical wiring (refer to MD maintenance manuals for information).

The internal harness for the secondary cargo hook is included (in addition to the external harness). The schematic is shown below. The relay is mounted forward of the battery under the pilot's feet (refer to Figure 25.16.5). The optional load weigh system's schematic is shown in Figure 25.15.3.

Inspect for general condition and chafing along length of wire runs.

**Figure 25.15.2 Electrical Schematic (Secondary Cargo Hook)**

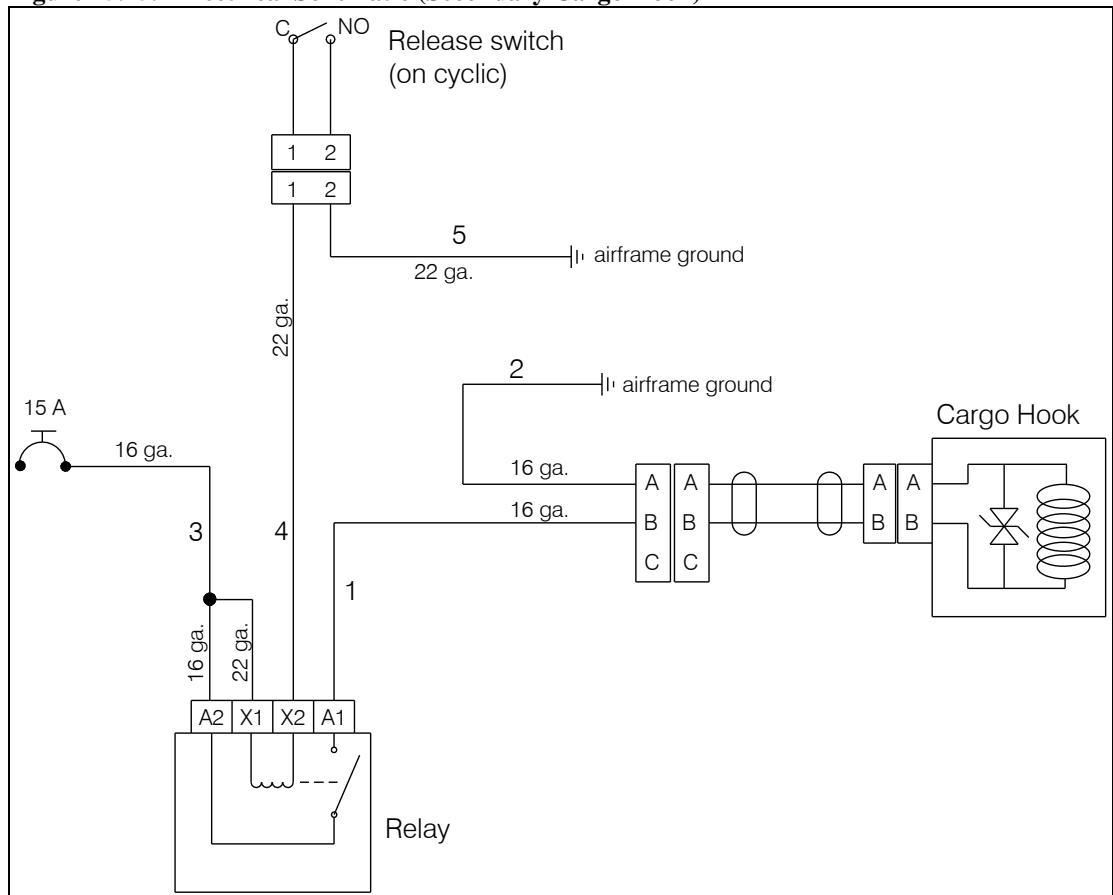

**Table 25.3 Notes continued:**

**2. Checking Wire Harnesses continued**

The load weigh system schematic is shown below. The Load Indicator (C-39 or C-40 model) position is optional within the cockpit, the belly disconnect is below the pilot's seat near the electrical release connector, and the pin load cell is at the primary cargo hook (serves as the cargo hook attach bolt).

The harness provided with the C-39 Indicator is P/N 270-047-01 and the harness provided with the C-40 Indicator is P/N 270-283-02. The C-39 and C-40 Indicators are interchangeable and can be used with either harness with the exception of the optional data connector not being present with the C-40 Indicator harness. Optional items such as the Onboard Systems Remote Analog Meter and C-30 Data Recorder are not compatible with the C-40 Indicator.

**Figure 25.15.3 Electrical Schematic (Load Weigh System)**

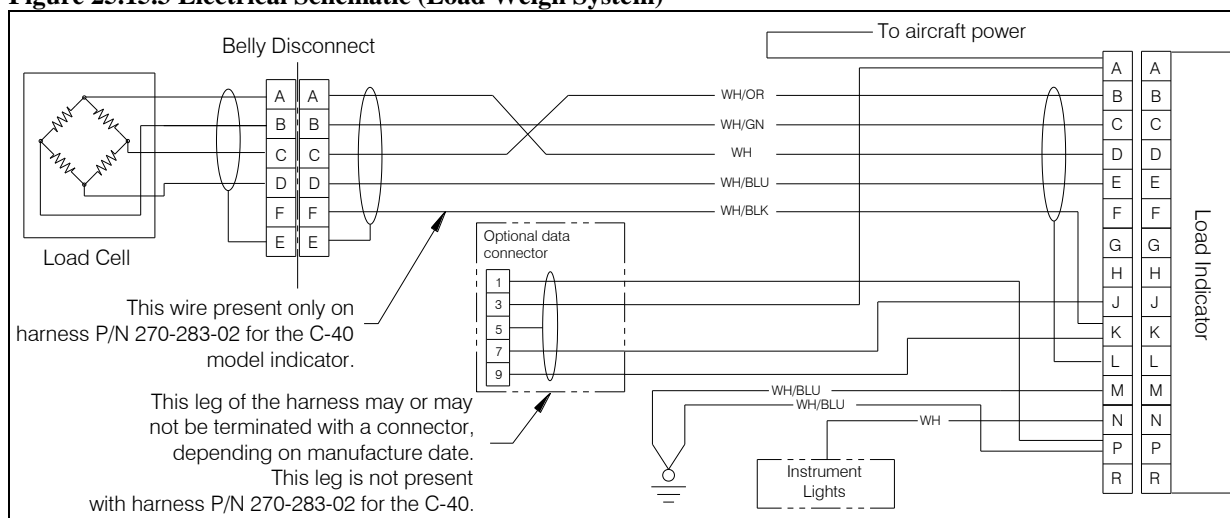

## 25.16 Component Removal

### Cargo Hook Removal

1. Cut and remove safety-wire at the slave cylinder assembly.
2. Remove the slave cylinder assembly by removing two screws (refer to Figure 25.16.2) and associated cable tie securing the hose into the groove of the manual release cover.
3. Disconnect the electrical release harness connector at the cargo hook.
4. Remove the cotter pin (P/N 510-178-00) from the Attach Bolt (P/N 290-332-00) or the Pin Load Cell (if the load weigh system is installed).
5. Remove the castellated nut (P/N 510-170-00) from the Attach Bolt or Pin Load Cell.
6. Remove Attach Bolt (or Pin Load Cell) and washers.
7. Remove the cargo hook.

### Attach Point Assembly Removal

1. Remove cargo hook per the above instructions.
2. Cut safety-wire (primary attach point only) and remove the four bolts that secure the Attach Point Assembly and Spacer Assembly (primary attach point only) to the belly of the helicopter and the loop clamps (not shown) that support the hydraulic hoses and electrical harnesses.

**Figure 25.16.1 Attach Point Assembly Removal (Primary)**

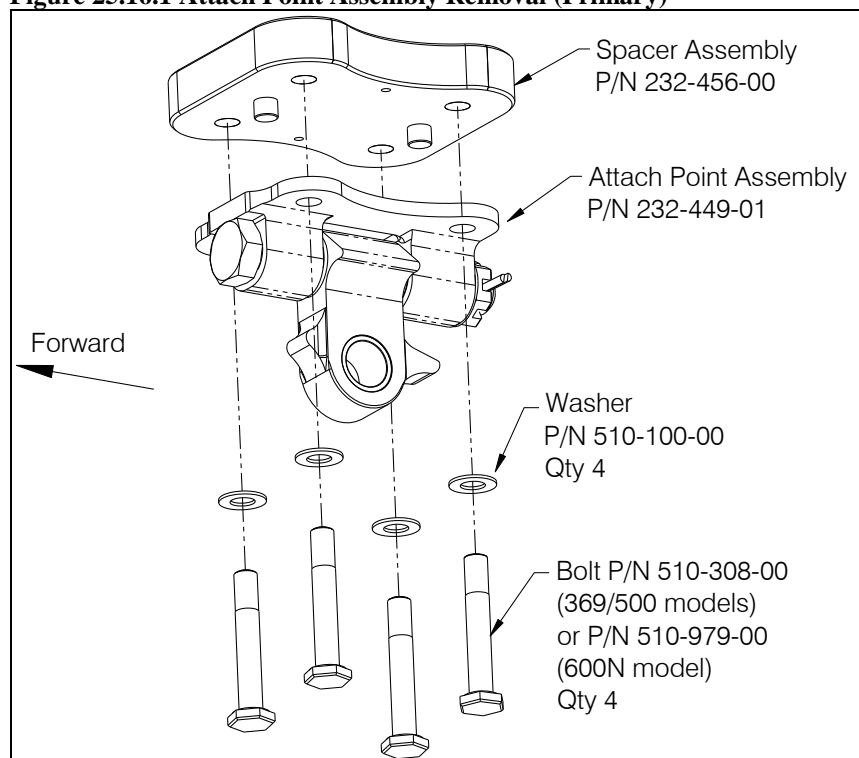

## 25.16 Component Removal continued

### Slave Cylinder and Plumbing Assembly Removal

The following steps are applicable to both the primary and secondary cargo hooks.

1. Disconnect the hoses at the quick disconnect fittings on the exterior of the aircraft (beneath the pilot's seat) and remove the hoses from the supporting clips along the belly of the helicopter by removing the screws and nuts securing the loop clamps to the clips.
2. At the Attach Point Assembly remove the bolts that secure the loop clamps which the hoses are routed through and remove the loop clamps from around the hoses.
3. Cut safety wire and remove the two screws that attach the slave cylinder assembly to the cargo hook (ref. Figure 25.16.2).
4. Remove the cable tie that secures the hydraulic hose to the manual release cover of the cargo hook.

Figure 25.16.2 Slave Cylinder Assembly Removal

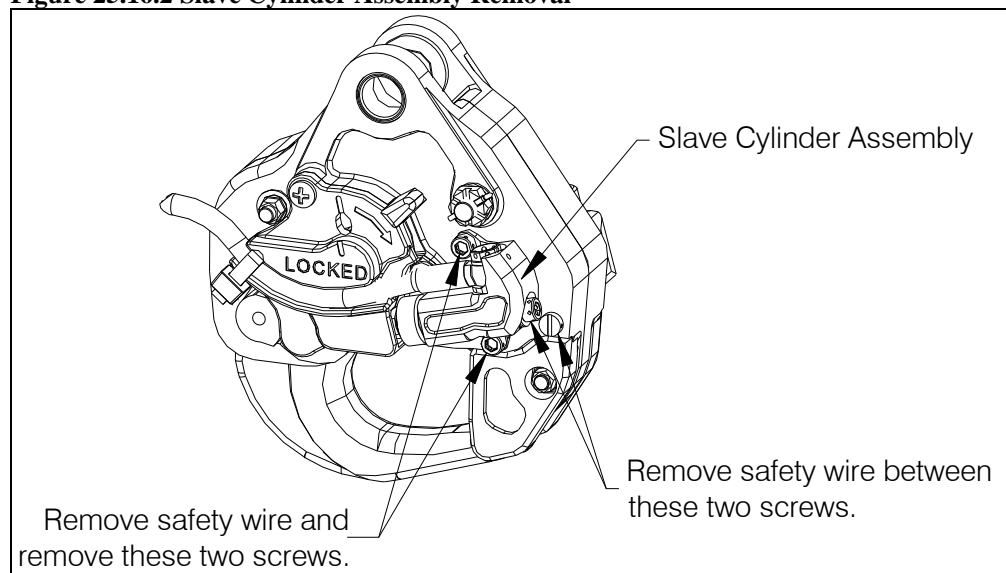

## 25.16 Component Removal continued

### Internal Hydraulic Release System Removal

The internal components of the hydraulic release system include the dual master cylinder assembly clamped to the cyclic tube just forward of the grip and the hoses routed to underneath the cabin floor where they are mated via quick disconnect fittings with the hoses from the cargo hooks.

Figure 25.16.3 Master Cylinder and Plumbing Installation Overview

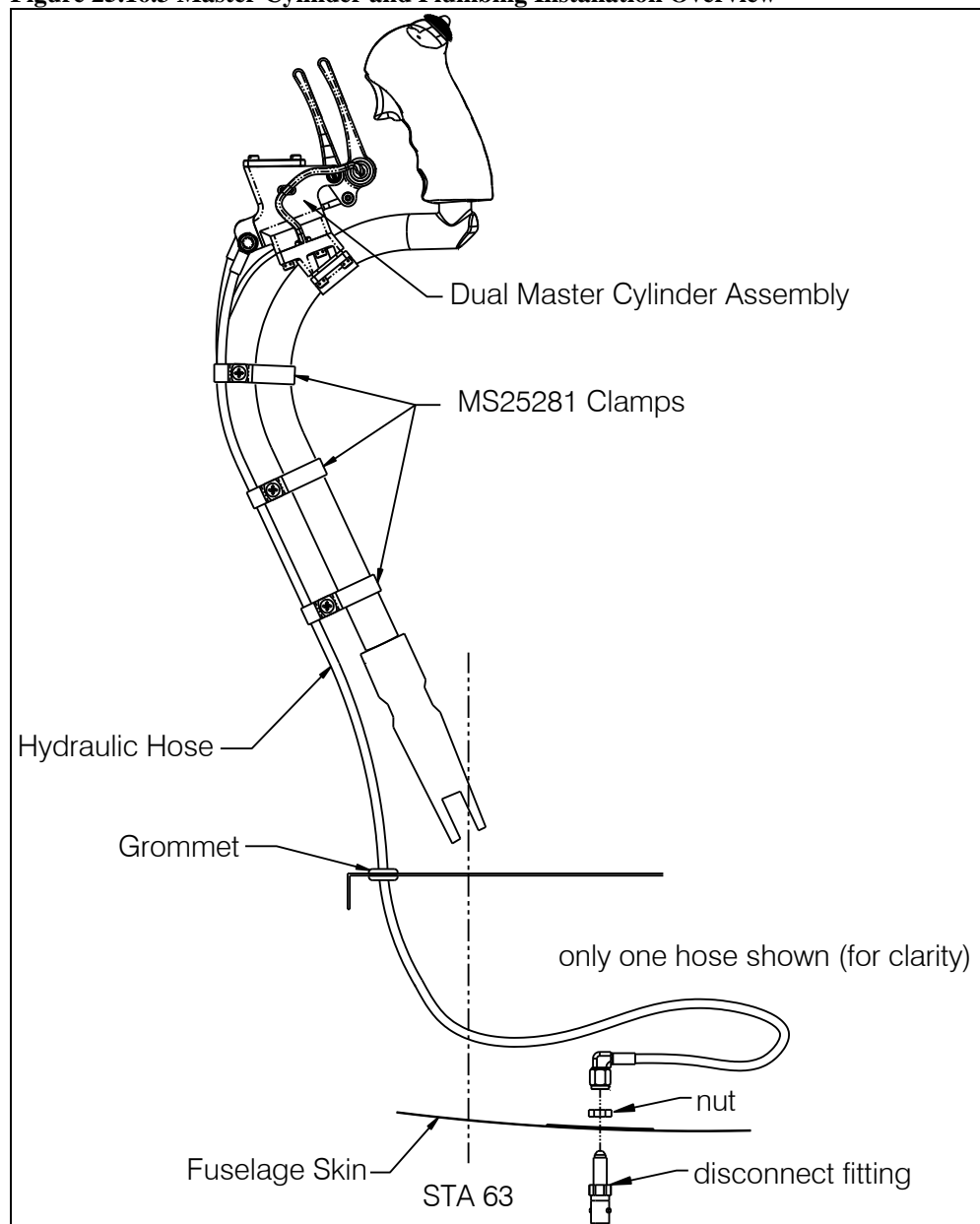

## 25.16 Component Removal continued

### Internal Hydraulic Release System Removal continued

Remove the internal hydraulic release system components per the following.

1. Disconnect the master cylinder plumbing from the slave cylinder plumbing by separating the quick disconnect fitting from underneath the aircraft. Drain the fluid from the master cylinder plumbing and reservoir.
2. From inside the aircraft, under the pilot seat, unthread the 90° fitting on the end of the hose and remove it and the nut from the disconnect fitting (ref. Figure 25.16.3). Repeat for the other hose.
3. Remove the hoses and the electrical harness for the release switch from the three clamps on the cyclic tube.
4. Disconnect the electrical harness at the connector.
5. Remove the grommets from the holes near the base of the cyclic.
6. Pull the hoses up through the holes.
7. Remove the dual master cylinder from the cyclic by cutting safety wire between the two pairs of screws and removing the screws (see below).

**Figure 25.16.4 Master Cylinder Removal**

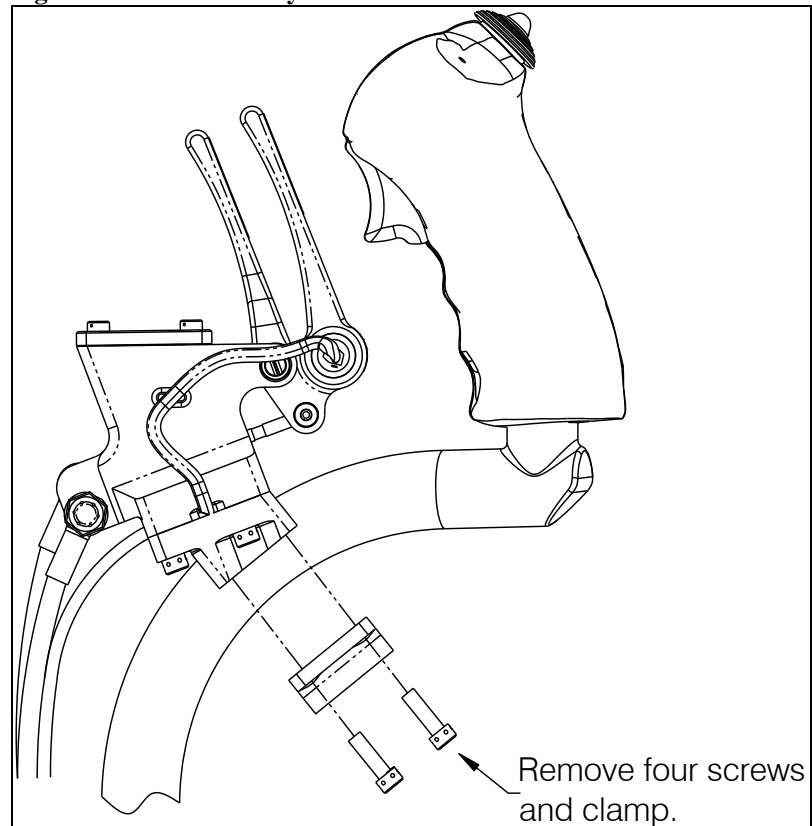

## 25.16 Component Removal continued

### Relay Removal

The relay (P/N 445-005-00) for the secondary cargo hook is located under the feet of the pilot's foot well, forward of the battery.

1. Remove the nut and washer from each of the two studs that secure the relay to the bracket.
2. Unplug the replay from the socket of the internal electrical harness.

**Figure 25.16.5 Secondary Cargo Hook Relay Location**

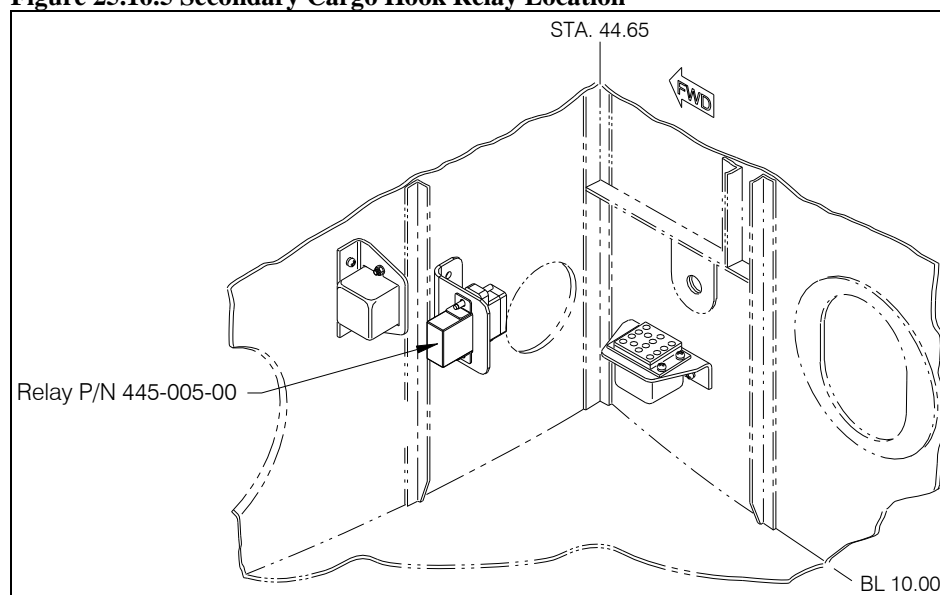

### Pin Load Cell Removal

The pin load cell is present at the primary cargo hook if the optional load weigh system is installed.

1. Disconnect the electrical connector at the connector panel on the belly of the helicopter (under the pilot seat).
2. Moving aft, remove the two loop clamps along the belly to free the load cell harness.
3. At the primary cargo hook, separate the pin load cell harness from the harness/hose bundle by removing the spiral wrap from around the bundle and remove the loop clamp at the forward right bolt securing the Attach Point Assembly to the aircraft hard point.
4. Remove the cotter pin (P/N 510-178-00), nut (P/N 510-170-00), washer (P/N 510-174-00), and washer (P/N 510-183-00) from the load cell and remove the load cell from the cargo hook.

### Load Weigh Indicator Removal

The load weigh indicator location is optional within the cockpit. It is designed to fit within a standard 2 1/4" instrument panel hole.

1. Remove the four screws that secure the indicator to its mount.
2. Disconnect the electrical connector from the back of the indicator.

## 25.16 Component Removal continued

### Release Switch Removal

The release switch for the secondary cargo hook is housed within the secondary cargo hook release lever on the dual master cylinder assembly.

1. Remove the nut from the button side of the switch.

**Figure 25.16.6 Release Switch Removal**

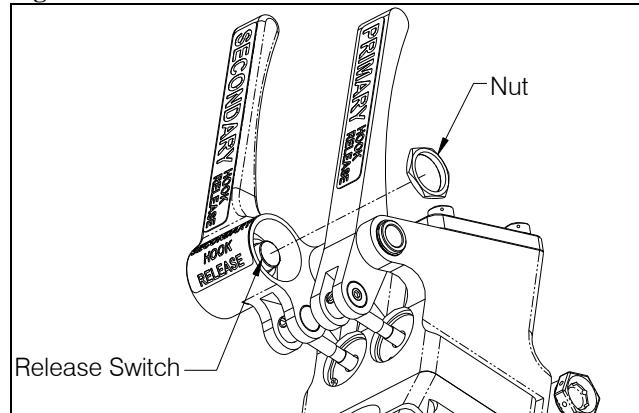

2. Slide the switch out of its housing and un-solder the wires from each of its contacts.

## NOTICE

*The primary cargo hook uses the original MDHI installed cargo release switch in the cyclic grip. Refer to MDHI documentation for this switch.*



## 25.17 Component Re-installation

### Primary Attach Point Assembly Re-installation

1. Orient and install the primary (forward) cargo hook's Attach Point components to the belly of the helicopter using the hardware as illustrated below, leaving the forward bolts and washer off (or loosely threading in) until the electrical harnesses and hose are routed through support hardware to be installed here.
2. Torque the two bolts to 50-80 in-lbs.

Figure 25.17.1 Primary Attach Point Re-installation

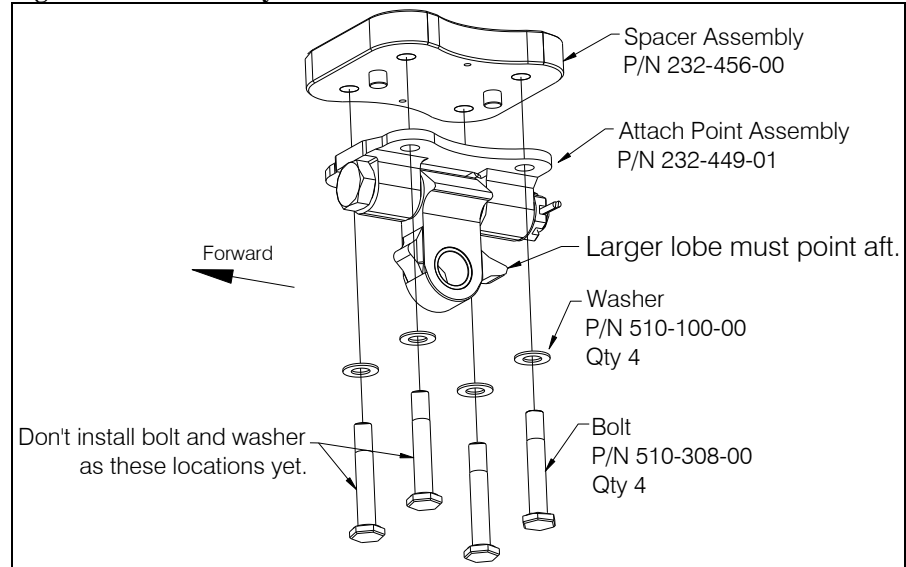

## 25.17 Component Re-installation

### Secondary Attach Point Assembly Re-installation

1. Install the secondary (aft) cargo hook Attach Point components to the belly of the helicopter using the hardware as illustrated below, leaving the aft right bolt and washer off until the electrical harnesses and hose are routed through a cushioned loop clamp to be installed here.
2. Torque the three bolts to 50-80 in-lbs.

**Figure 25.17.2 Secondary Attach Point Re-installation**

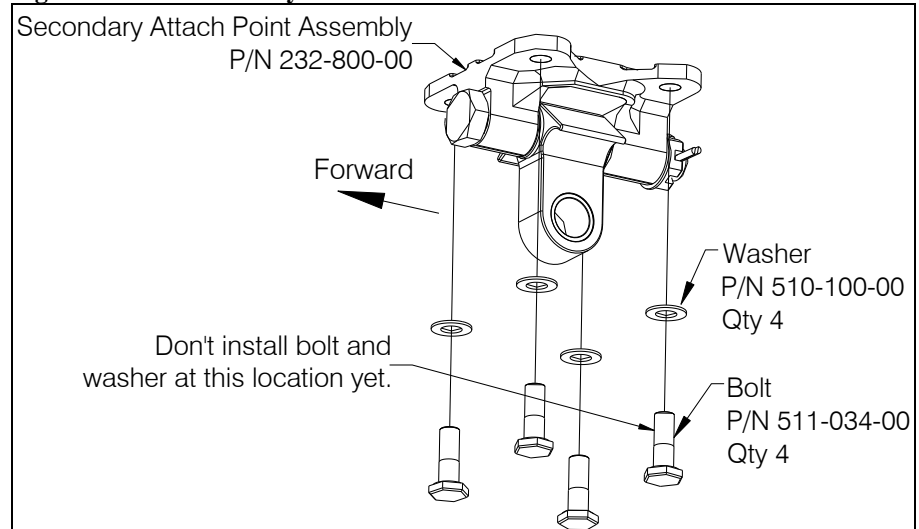

## 25.17 Component Re-installation continued

### Cargo Hook Re-installation

1. Assemble Slave Cylinder with Plumbing assembly (P/N 232-804-00 for the 369/500N models, P/N 232-804-01 for the 600N) onto the secondary Cargo Hook (P/N 528-028-03)
2. Assemble Slave Cylinder with Plumbing assembly (P/N 232-808-00 for the 369/500N models, P/N 232-808-01 for the 600N) onto the primary Cargo Hook (P/N 528-028-00) per the instructions in this section.

Note: Other than the P/N, the Slave Cylinder with Plumbing assemblies can be differentiated by length: the hose to the secondary cargo hook is 6 inches longer.

3. Connect release harness P/N 270-132-00 (P/N 270-132-02 for the 600N) to mating cargo hook P/N 528-028-00 connector.
4. Connect release harness P/N 270-236-00 (P/N 270-236-01 for the 600N) to mating secondary cargo hook P/N 528-028-03 connector.
5. Insert the Bumper (P/N 290-360-01) into the clevis of the secondary cargo hook (P/N 528-028-03), reference Figure 25.17.3.
6. Attach each Cargo Hook to their respective attach point assembly with the hardware shown in Figure 25.17.4 (the primary and secondary cargo hooks are installed using identical hardware part numbers).

If the load weigh system is installed, the primary cargo hook is attached to the forward attach point assembly with the pin load cell. This installation is shown in Figure 25.17.5.



*The Cargo Hooks must be oriented as shown in the figure below. The primary attach point assembly is “keyed” thus if the cargo hook cannot be installed in the orientation shown below the attach point assembly must be reversed.*

Figure 25.17.3 Cargo Hook Orientation (primary hook shown)

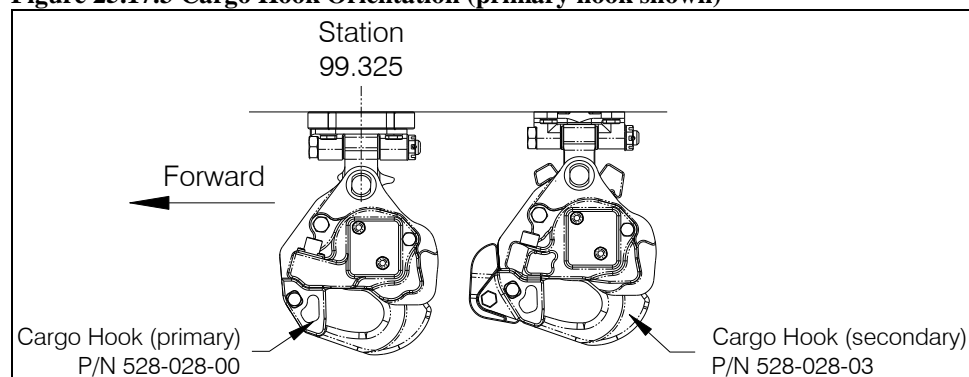

## 25.17 Component Re-installation continued

### Cargo Hook Re-installation

7. Tighten nut on Attach Bolt (or Pin Load Cell if installed) until fully seated, finger tight only. Back off nut to previous castellation, if needed, when aligning cotter pin for installation. Install and secure cotter pin (P/N 510-178-00).
8. Route electrical harnesses and hydraulic hoses per Figure 25.17.6 and Figure 25.17.7.
9. After harness and hoses are routed, tighten the remaining bolts at the attach point assemblies to 50-80 in-lbs. and safety wire the bolts at the primary attach point assembly.

**Figure 25.17.4 Cargo Hook Attachment Hardware (Secondary Hook Shown)**

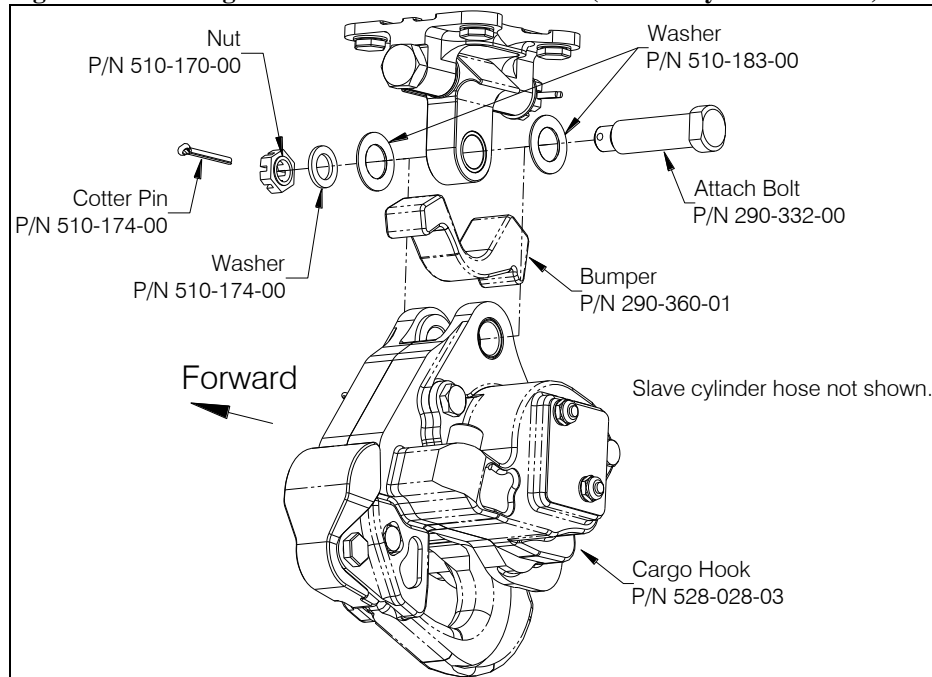

**Figure 25.17.5 Primary Cargo Hook Attachment w/ Pin Load Cell**

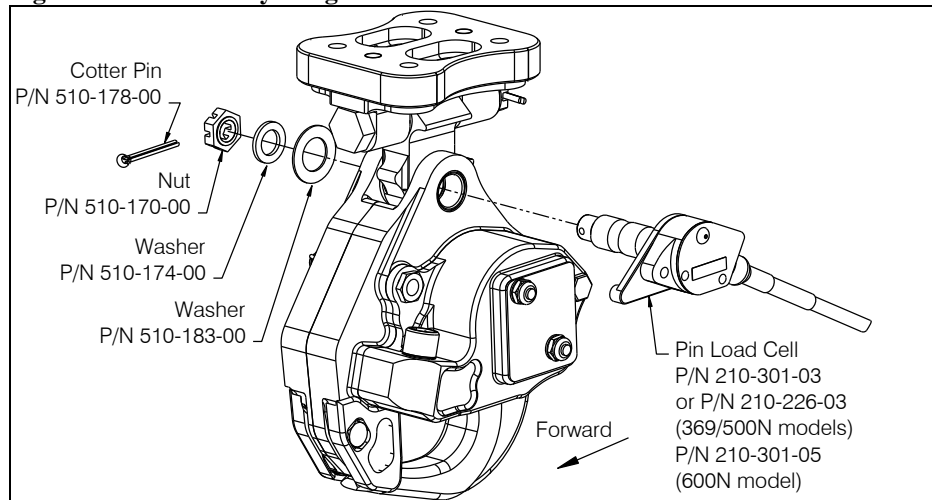

## 25.17 Component Re-installation continued

### Slave Cylinder Assembly Re-installation

Connect the slave cylinder assembly to the cargo hook per the following instructions:

1. Ensure that the piston is in the retracted position. If the piston needs to be retracted connect the quick disconnect fitting and push the piston in.



*The piston will not be able to be retracted if the hydraulic hose is not connected at the quick disconnect.*

2. Insert the piston end of the slave cylinder assembly into the side of the cargo hook as shown (ref Figure 25.17.6) and install the mounting screws (P/N 510-531-00). Torque screws to 12-15 in-lbs.
3. Install safety wire between these screws around the backside of the slave cylinder.
4. Route the hydraulic hose along the manual release cover and secure with a cable tie through the hole at the end of the groove in the manual release cover.

**Figure 25.17.6 Slave Cylinder Assembly Installation**

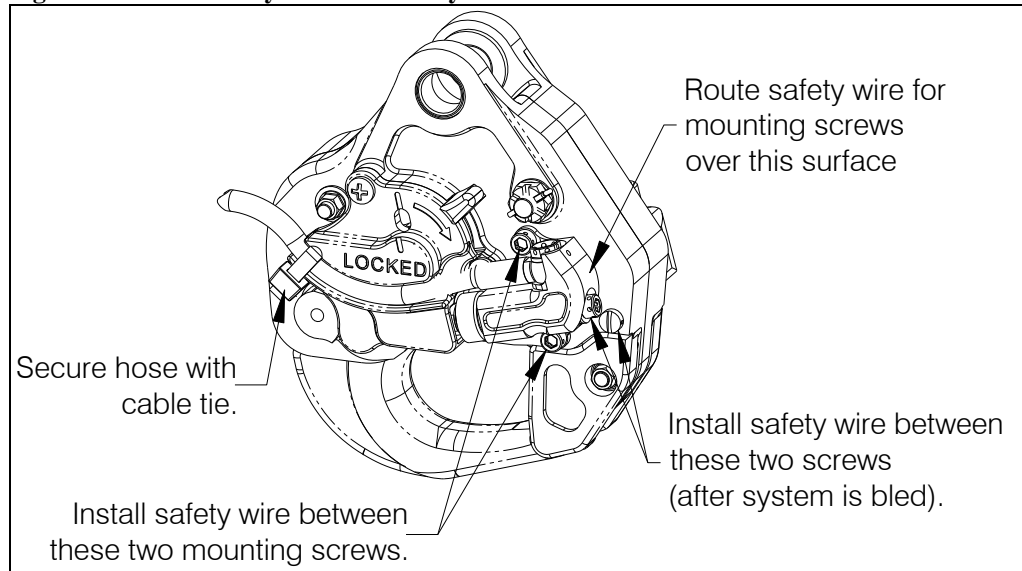

## 25.17 Component Re-installation continued

### External Electrical Harness and Hose Routing

1. For the primary cargo hook route the electrical harnesses and hydraulic hose as shown in Figure 25.17.7. Before tightening loop clamp, ensure that there is sufficient slack in the harness and hose bundle to allow for full movement of the cargo hook.
2. Re-install spiral wrap (P/N 590-013-00) over harness and hose.

**Figure 25.17.7 Hydraulic Hose and Electrical Harness Routing at Primary Cargo Hook**

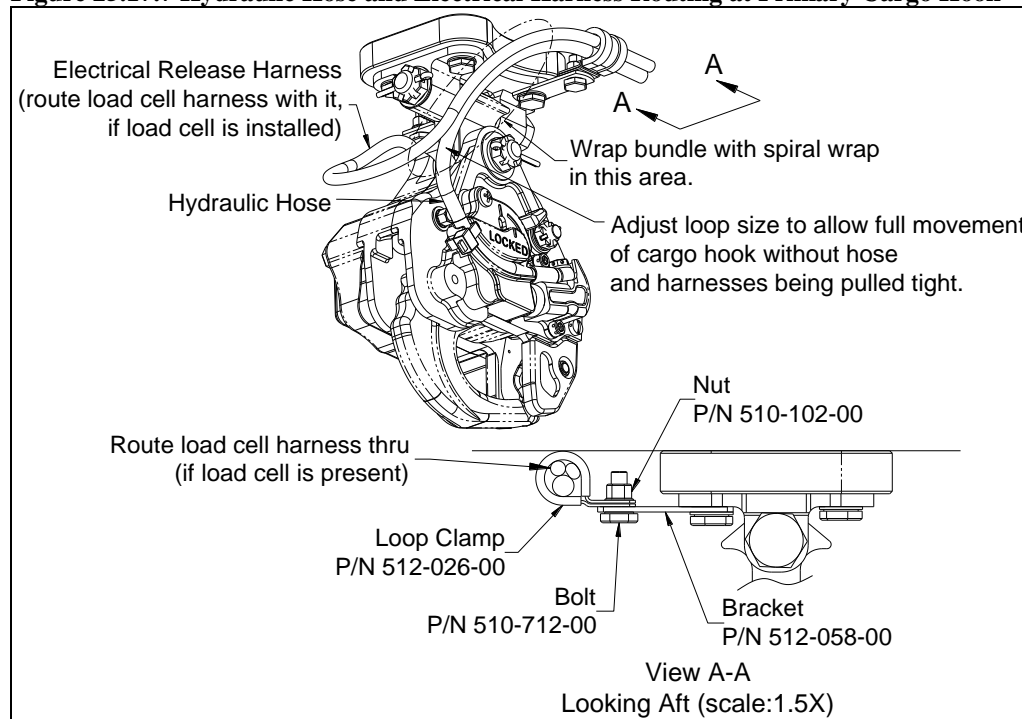

## 25.17 Component Re-installation continued

### External Electrical Harness and Hose Routing continued

3. For the secondary cargo hook, route its electrical release harness and hydraulic hose on the left side and through loop clamp P/N 290-909-00 attached at the aft left bolt attaching the secondary attach point assembly's pillow block.
4. Route the harness and hose forward and secure with hardware shown in View A-A at the forward left bolt of the primary attach point assembly's pillow block.

Figure 25.17.8 Hose and Harness Routing from Secondary Cargo Hook

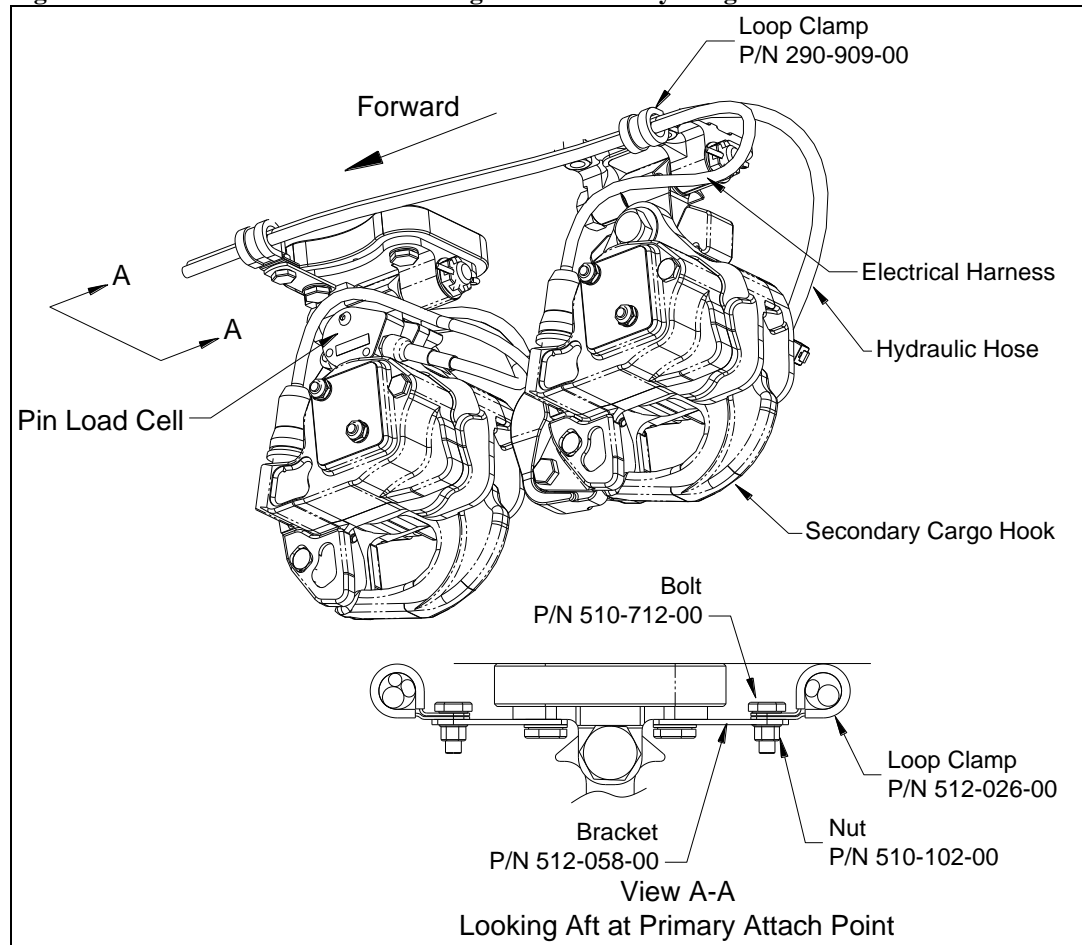

## 25.17 Component Re-installation continued

### External Electrical Harness and Hose Routing continued

- Forward of the attach point assemblies re-attach the hoses and harnesses to the support clips as shown below. The secondary cargo hook's hose and harness are routed outboard of the primary cargo hook's hose and harness. The 369/500N is shown in the layout below, the 600N is the same except the support clips are located at different station lines (i.e. – spread out to accommodate the 30" longer fuselage).
- Connect each hose and harness to the fixed connectors as shown below.

Figure 25.17.9 External Hose and Harness Routing (369/500N model shown)

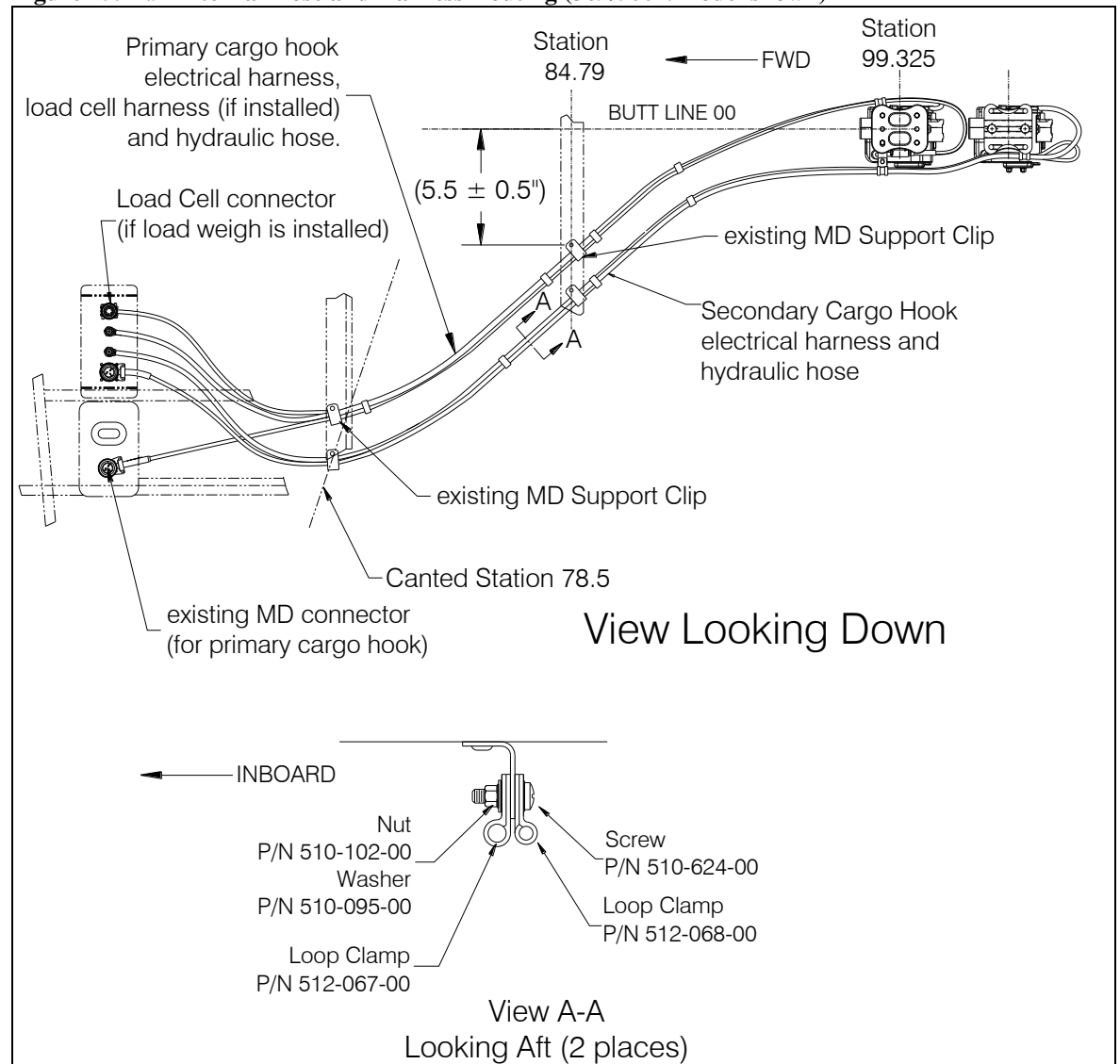



## 25.17 Component Re-installation continued

### Internal Hydraulic Release System Re-installation

1. Install the dual master cylinder onto the cyclic with the four screws (P/N 511-189-00). Tighten screws to 20-25 in-lbs.
2. Attach the hoses and the electrical harness to the three sets of clamps on the pilot's cyclic tube (see Figure 25.17.10).
3. Feed the ends of the hydraulic hoses through the holes at the base of the pilot seat. Re-install the grommets.
4. Underneath the floor route the ends of the hydraulic hoses slightly inboard and aft to the Connector Doubler installed in the belly of the helicopter.



*The hydraulic hoses are crossed from the Dual Master Cylinder to the Connector Doubler. The Primary Hook Release lever on the right (inboard) moves fluid through the hose exiting the left side of the master cylinder. This hose is connected to the inboard hole at the Connector Doubler.*

5. Remove the nuts and disconnect fittings (if assembled) and insert the disconnect fittings up through the Connector Doubler in the skin and thread the nuts over each fitting and tighten securely.
6. Position the hose elbow fitting for the primary cargo hook at the inboard hole of the Connector Doubler and orient the loop of hose aft and clear of surrounding wires/equipment. With the hose oriented tighten the elbow fitting securely.
7. Repeat the previous step for the secondary cargo hook fitting at the outboard hole.

**25.17 Component Re-installation** continued  
**Internal Hydraulic Release System Re-installation** continued

**Figure 25.17.10 Internal Hydraulic Release System Installation**

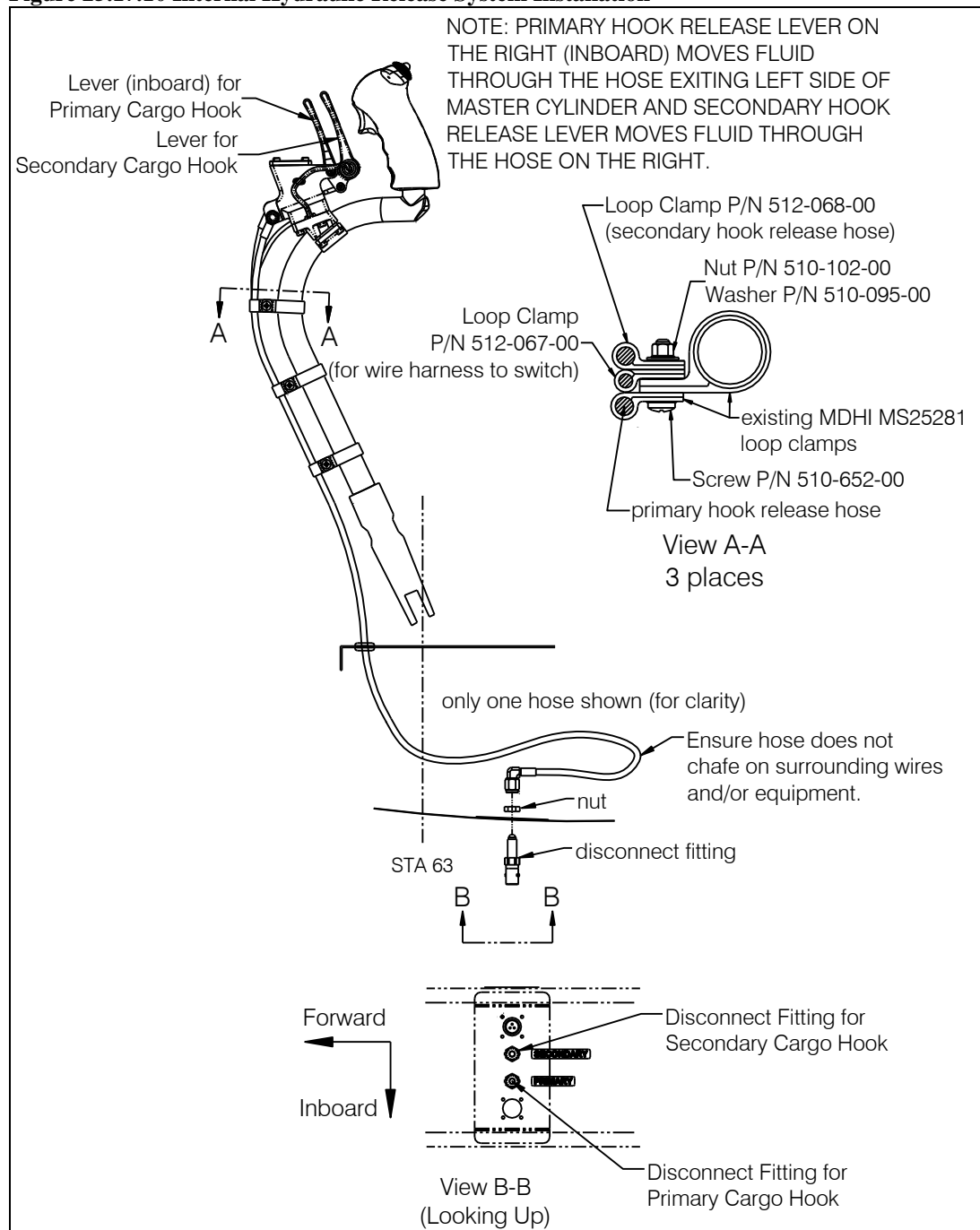

## 25.17 Component Re-installation continued

### Internal Hydraulic Release System Re-installation continued

8. After completing installation of the hydraulic system (both fixed and removable) bleed the system per section 12.2.
9. If desired, adjust the position of the release levers (see below). Loosen the set screw at the lever desired for adjustment and using a small screwdriver turn the push rod in the desired direction. Maintain minimum of one thread protruding past the barrel nut and ensure there is no interference with the cyclic in any combination of lever movements. Secure push rod threads with set screws.

Figure 25.17.11 Lever Adjustment

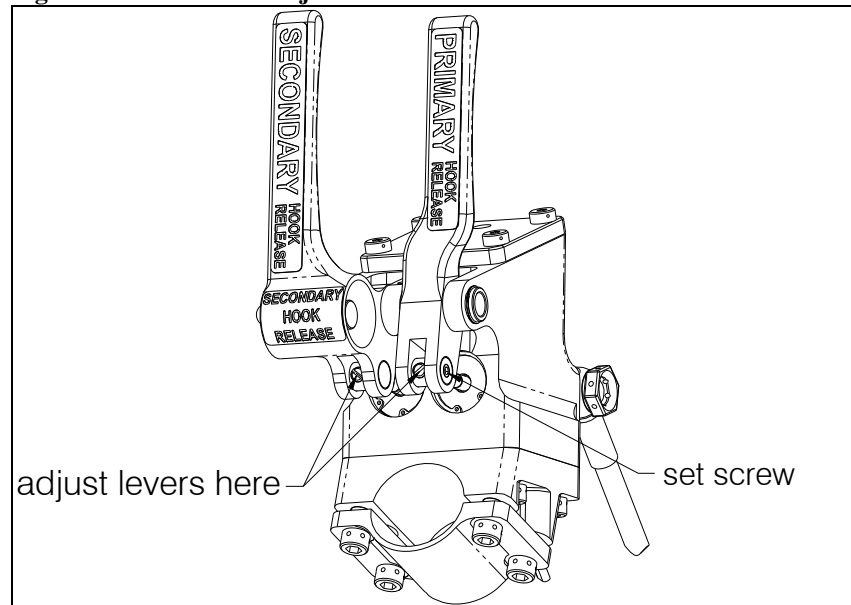

10. Install safety wire between the two pairs of mounting screws attaching the dual master cylinder to the cyclic.
11. Connect the electrical harness connector for the secondary cargo hook release switch to the internal harness connector.

## 25.17 Component Re-installation continued

### Relay Re-installation

The relay is located on the bulkhead forward of the battery, under the pilot's feet.

1. Plug the relay (P/N 445-005-00) into the relay socket of the internal electrical harness mounted to the Relay Bracket installed on the forward bulkhead (not shown).
2. Secure the relay to each stud of the relay socket with washer and nut (this hardware is included with socket).

**Figure 25.17.12 Relay Re-installation**

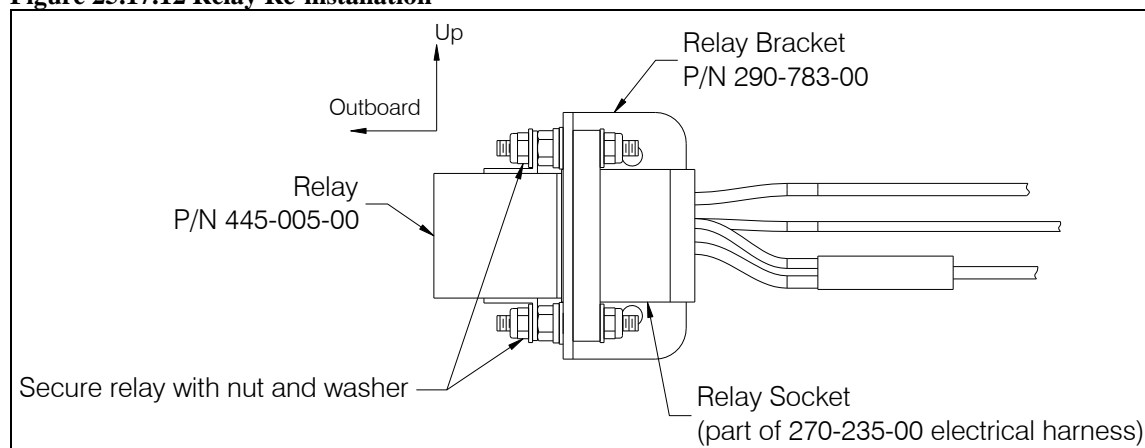

### Release Switch Re-installation

The secondary cargo hook's release switch is integrated within the secondary cargo hook's release lever on the dual master cylinder.

1. Solder the two wires from the harness (that is routed up the cyclic) to the contacts on the back of the switch.
2. Insert the switch from the left side of the release lever (ref. Figure 25.16.6) into the housing and thread the nut on and tighten securely.

### Load Weigh Indicator Re-installation

The load weigh indicator location is optional within the cockpit.

1. Place the Load Weigh Indicator into the mounting location and secure with four 6-32 screws (P/N 511-211-00 or other length of MS35214 screw).
2. Connect the electrical connector on the wiring harness to the connector on the back of the indicator.