	Instructions for Continued Airworthiness	Document Number 123-053-00	Revision 1
		Date 04/15/2022	Page 1 of 38

**Instructions for
Continued Airworthiness**
for
Cargo Hook Kits
on the
Airbus Helicopters Deutschland GmbH
**EC135P1, EC135T1, EC135P2, EC135T2, EC135P2+,
EC135T2+, EC135P3, EC135T3**
STC SR02217SE

System Part Numbers
200-375-01
200-467-00
200-476-XX

Onboard Systems International, LLC
13915 NW 3rd Court
Vancouver, WA 98685 United States of America
Cage Code: 1Y921

Toll Free Phone: (800) 275-0883
Phone: (360) 546-3072
Fax: (360) 546-3073

[Please check our web site www.onboardsystems.com](http://www.onboardsystems.com)
[for the latest revision of this manual.](#)

	Instructions for Continued Airworthiness	Document Number 123-053-00	Revision 1
		Date 04/15/2022	Page 2 of 38

RECORD OF REVISIONS

Revision	Date	Page(s)	Reason for Revision
0	03/02/2022	All	Initial Release
1	04/15/2022	9, 12	Corrected title of Section 4 in Section 0.5. In Section 4.1: added Maximum Life for Long Line Kit components, corrected long line P/N.

Register Your Products for Automatic Notifications

Onboard Systems offers a free notification service via fax or email for product alerts and documentation updates. By registering your Onboard Systems products at our website, we will be able to contact you if a service bulletin is issued, or if the documentation is updated.

You can choose to receive notices on an immediate, weekly, or monthly schedule via fax, email or both methods. There is no charge for this service. Please visit our website at www.onboardsystems.com/notify.php to get started.

	Instructions for Continued Airworthiness	Document Number 123-053-00	Revision 1
		Date 04/15/2022	Page 3 of 38

Contents

Section 0	Introduction	5
0.4	Scope.....	5
0.5	Arrangement.....	9
0.6	Applicability.....	9
0.9	Abbreviations	9
0.12	Safety labels	10
0.19	Distribution of Instructions for Continued Airworthiness	11
Section 4	Airworthiness Limitations	12
4.1	Long Line Kit.....	12
4.2	Cargo Hook.....	12
Section 5	Inspection and Overhaul Schedule	13
5.1	Cargo Hook Kit Inspection	13
5.2	Long Line Kit Inspection	16
5.2.1	Y-rope Inspection	19
5.2.2	Long Line Inspection	20
5.2.3	Lanyard Inspection	21
5.3	Cargo Hook Overhaul.....	25
Section 11	Placards and Markings	26
Section 25	Equipment and Furnishings.....	28
25.5	Component Weights and CG.....	28
25.12	Storage Instructions.....	28
25.15	Trouble Shooting	29
25.16	Component Removal	30
25.16.1	Cargo Hook Removal	30
25.16.2	Manual Release Cable Removal.....	32
25.17	Component Re-installation	33
25.17.1	Cargo Hook Re-installation	33
25.17.2	Manual Release Cable Re-installation	36
25.18	General Procedural Instructions – Testing	38

	Instructions for Continued Airworthiness	Document Number 123-053-00	Revision 1
		Date 04/15/2022	Page 4 of 38

Figures

Figure 0.4.1 Dual Cargo Hook Kit P/N 200-467-00 Overview	5
Figure 0.4.2 Overview of Cargo Hook, Manual Release Side	6
Figure 0.4.3 Overview of Cargo Hook, Electrical Side	7
Figure 0.4.4 Long Line Kit	8
Figure 5.1.1 Hook Lock Indicator	14
Figure 5.1.2 Examples of Manual Release Cable Damage	14
Figure 5.1.3 Manual Release Cable Rigging Check	15
Figure 5.2.1 Long Line Kit	17
Figure 5.2.2 Rigging Plate Inspection Criteria	24
Figure 25.16.1 Cargo Hook Removal	30
Figure 25.16.2 Manual Release Cover Removal	31
Figure 25.16.3 Forward Bearing Housing	31
Figure 25.16.4 Bearing Housing and Pivot Removal	32
Figure 25.17.1 Manual Release Cover Removal	33
Figure 25.17.2 Release Cable Setting	34
Figure 25.17.3 Inner Cable Positioning	34
Figure 25.17.4 Cargo Hook Installation within Beam	35
Figure 25.17.5 Manual Release Cable Connection at Panel	36
Figure 25.17.6 Manual Release Cable Rigging Check	37

	Instructions for Continued Airworthiness	Document Number 123-053-00	Revision 1
		Date 04/15/2022	Page 5 of 38

Section 0 Introduction

0.4 Scope

The information in this Instructions for Continued Airworthiness is necessary to carry out the service, maintenance, and inspection of Single Cargo Hook Kit P/N 200-375-01, Dual Cargo Hook Kit P/N 200-467-00 and Long Line Kit P/N 200-476-XX.

The Single Cargo Hook Kit is approved for carrying of NHEC on EC135 helicopters equipped with a TC approved single cargo hook beam. The cargo hook kit replaces the cargo hook and the external electrical release harness and manual release cable that route to the disconnect panel on the belly.

The Dual Cargo Hook Kit is approved for carrying of NHEC and HEC on EC135 helicopters equipped with a TC approved double cargo hook beam. The dual cargo hook kit replaces both cargo hooks and their external electrical release harnesses and manual release cables that route to the disconnect panel on the belly. The complete kit configuration is shown in Figure 0.4.1.

Figure 0.4.1 Dual Cargo Hook Kit P/N 200-467-00 Overview

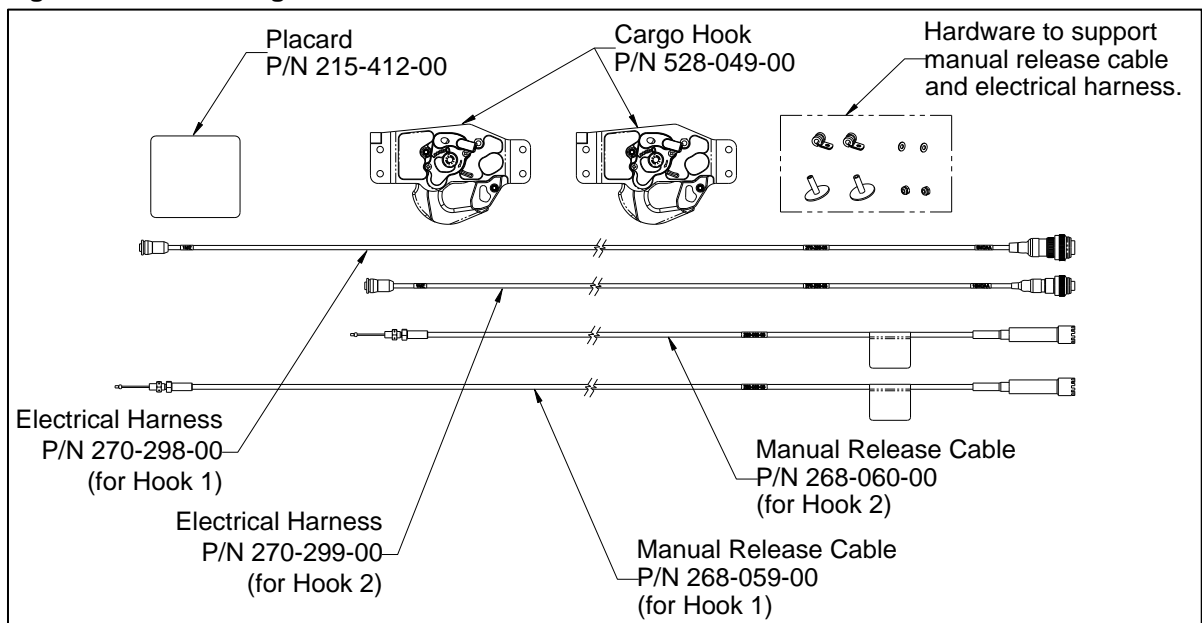

	Instructions for Continued Airworthiness	Document Number 123-053-00	Revision 1
		Date 04/15/2022	Page 6 of 38

NOTICE

These kits do not include any components internal to the helicopter as the kit components are designed to interface with the existing fixed (internal) provisions as provided under the type certificate. These fixed provisions and the Airbus Helicopters structural beam in which the cargo hooks are installed in are to be maintained per the applicable Airbus Helicopters maintenance documentation.

An overview of Cargo Hook P/N 528-049-00 included with Dual Cargo Hook Kit P/N 200-467-00 is provided in the figures below. This Cargo Hook is identical to the Cargo Hook P/N 528-049-01 included with the Single Cargo Hook Kit except its placarded load rating is the TC double cargo hook beam load rating of 2205 lbs.

Figure 0.4.2 Overview of Cargo Hook, Manual Release Side

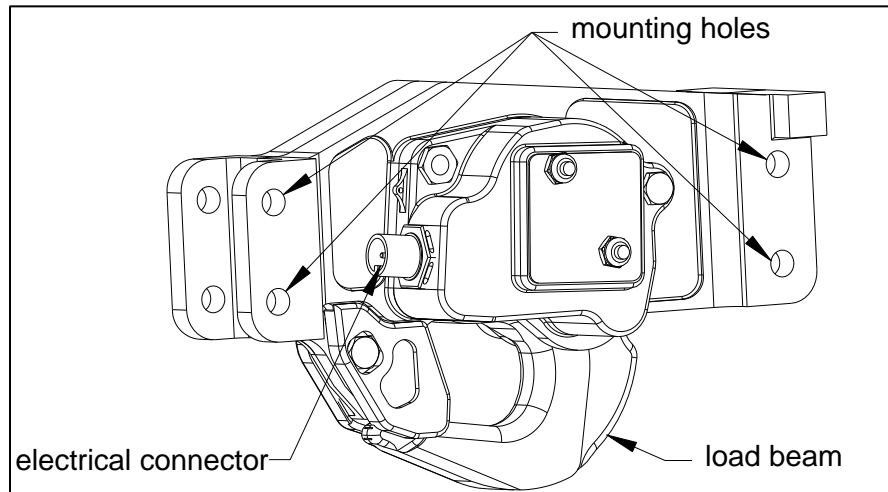

	Instructions for Continued Airworthiness	Document Number 123-053-00	Revision 1
		Date 04/15/2022	Page 7 of 38

Figure 0.4.3 Overview of Cargo Hook, Electrical Side



The Long Line Kit (P/N 200-476-XX*) includes the components shown in the figure below. The Y-rope is the only component of the long line kit that is required to be used with the dual cargo hook kit as it is designed to provide a controlled interface with the cargo hooks. For the components below the Y-rope (carabiner to lanyard), an alternative configuration or components approved by the local Aviation Authority may be used.

*The kit P/N is completed by replacing the XX by a two-digit number which is multiplied by 10 to define the length of the included long line, for example – kit P/N 200-476-10 includes a 100-foot long line (P/N 490-023-10), Kit P/N 200-476-15 includes a 150-foot long line (P/N 490-023-15), etc.

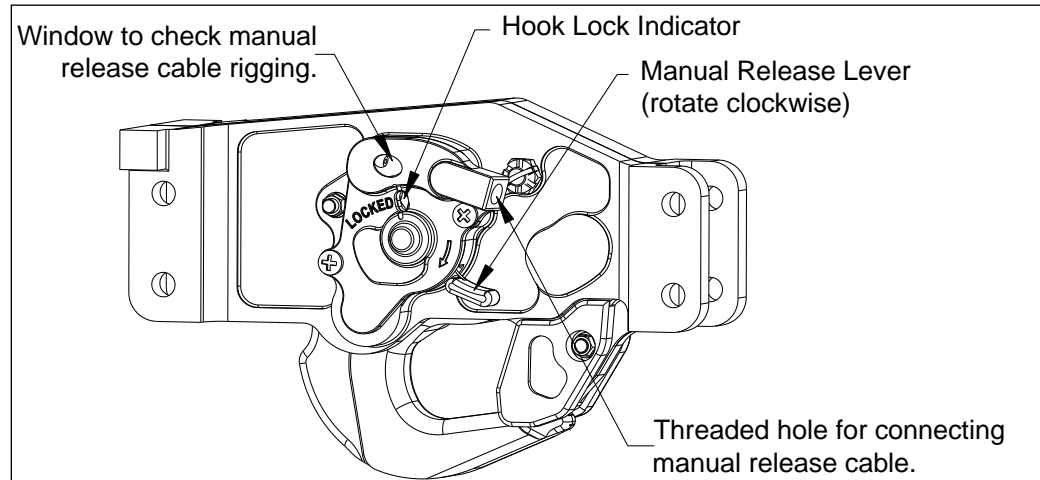
Figure 0.4.4 Long Line Kit

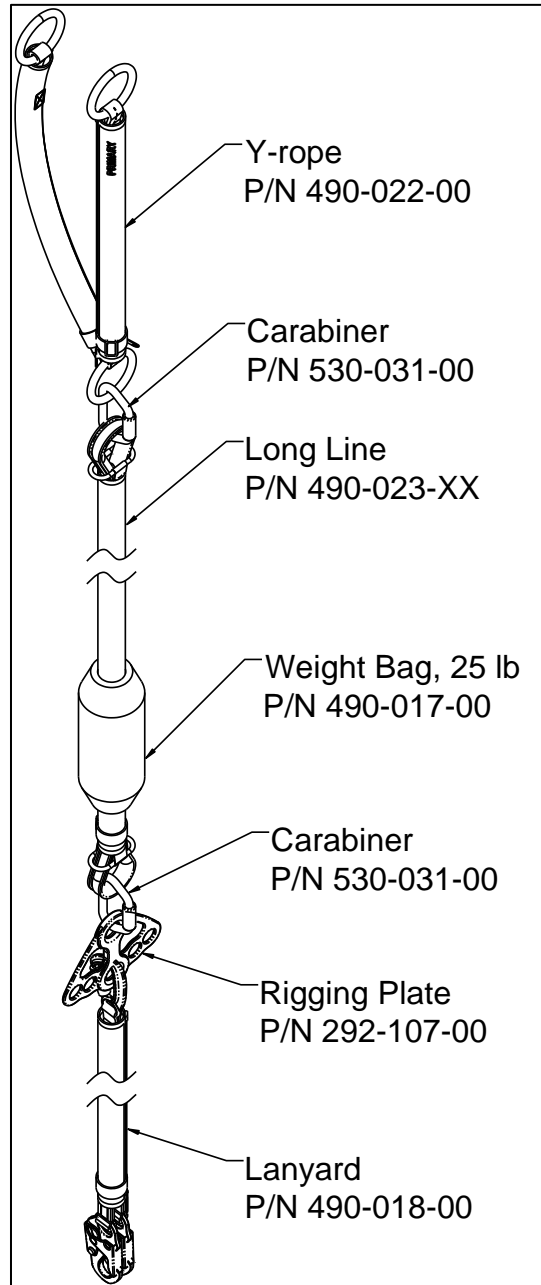

	Instructions for Continued Airworthiness	Document Number 123-053-00	Revision 1
		Date 04/15/2022	Page 9 of 38

0.5 Arrangement

The manual is arranged in the general order that maintenance personnel would use to maintain and operate the cargo hook kits in service.

The arrangement is:

Section 0 Introduction

Section 4 Airworthiness Limitations

Section 5 Inspection and Overhaul Schedule

Section 11 Placards and Markings

Section 25 Equipment and Furnishings

0.6 Applicability

These Instructions for Continued Airworthiness are applicable to Single Cargo Hook Kit P/N 200-375-01, Dual Cargo Hook Kit P/N 200-467-00 and Long Line Kit P/N 200-476-XX for Airbus Helicopters Deutschland GmbH models EC135P1, EC135T1, EC135P2, EC135T2, EC135P2+, EC135T2+, EC135P3, and EC135T3.

0.9 Abbreviations

CMM Component Maintenance Manual

ICA Instructions for Continued Airworthiness

FAA Federal Aviation Administration

	Instructions for Continued Airworthiness	Document Number 123-053-00	Revision 1
		Date 04/15/2022	Page 10 of 38

0.12 Safety labels

The following definitions apply to safety labels used in this manual.



Indicates a hazardous situation which, if not avoided, will result in death or serious injury.



Indicates a hazardous situation which, if not avoided, could result in death or serious injury.



Indicates a hazardous situation which, if not avoided, could result in minor or moderate injury.



Draws the reader's attention to important or unusual information not directly related to safety.



Used to address practices not related to personal injury.

	Instructions for Continued Airworthiness	Document Number 123-053-00	Revision 1
		Date 04/15/2022	Page 11 of 38

0.19 Distribution of Instructions for Continued Airworthiness

Before performing maintenance ensure that the Instructions for Continued Airworthiness (ICA) in your possession is the most recent revision. Current revision levels of all manuals are posted on Onboard Systems Int'l web site at www.onboardsystems.com.

Onboard Systems offers a free notification service via fax or e-mail for product alerts and documentation updates. By registering Onboard Systems products on the web site, we will be able to contact you if a service bulletin is issued, or if the documentation is updated.

Notices can be chosen to be received on an immediate, weekly, or monthly schedule via fax, email or both methods. There is no charge for this service. Visit the Onboard Systems web site at www.onboardsystems.com/notify.php to get started.

	Instructions for Continued Airworthiness	Document Number 123-053-00	Revision 1
		Date 04/15/2022	Page 12 of 38

Section 4 Airworthiness Limitations

The Airworthiness Limitations section is FAA approved and specifies inspections and other maintenance required under Secs. 43.16 and 91.403 of the Federal Aviation Regulations unless an alternative program has been FAA approved.

4.1 Long Line Kit

The following items of the Long Line Kit P/N 200-476-XX are life-limited. Captured metal parts (load rings, snap hooks, etc.) of the assemblies are also scrapped at retirement.

Part Number	Description	Maximum Service Life**	Maximum Life***
490-022-00	Y-Rope	4 years	6 years
490-023-XX*	Long Line	4 years	6 years
490-018-00	Lanyard	4 years	6 years

*The XX represents length of the long line in feet divided by 10, e.g. - a 100-foot Long Line is part number 490-023-10, a 150-foot Long Line is part number 490-023-15, etc.

** Service life begins when the item is placed into service. This date must be marked by the operator in the reserved location on the component ID tag or using another method such as recording in a log book.

*** Maximum life is from the "MFG Date" as marked on the component ID tag ("maximum life" accounts for shelf-life).

4.2 Cargo Hook

Cargo Hook P/N 528-049-00 is life-limited by cycles. Life cycle counting is dependent on the weights of the external loads lifted (payload factor), as specified in the table below.

Part Number	Service Life Limit	Payload Factors	
		Load	Payload Factor
528-049-00	68,750 life cycles	0 – 599 kg (0 – 1322 lb.)	0
		600 – 799 kg (1323 – 1761 lb.)	3
		800 – 1000 kg (1762 – 2205 lb.)	6

This cycle counting is applicable to the Cargo Hook in the Hook 1 (aft) position. The Cargo Hook in the Hook 2 (forward) position is not loaded during normal operation and is only for use in HEC operations, which are limited to a maximum load of 1323 lbs.

Life cycles = Number of Load Pick-ups x Payload Factor. An example calculation of cargo hook life cycles is shown below.

Payload Class	Number of Load Pick-ups	Payload Factors	Life Cycles
0 – 599 kg	19803	0	0
600 – 799 kg	5865	3	5865 x 3 = 17595
800 – 1000 kg	84	6	84 x 6 = 504
Total Pick-ups: 25752		Total Life Cycles: 18099	

	Instructions for Continued Airworthiness	Document Number 123-053-00	Revision 1
		Date 04/15/2022	Page 13 of 38

Section 5 Inspection and Overhaul Schedule

5.1 Cargo Hook Kit Inspection

The scheduled inspection intervals noted below are maximums and are not to be exceeded. If the cargo hook is subjected to unusual circumstances, extreme environmental conditions, etc., it is the responsibility of the operator to perform the inspections more frequently to ensure proper operation. Refer to the Component Maintenance Manual (CMM) 122-036-00 for additional maintenance information specific to the Cargo Hook including damage and wear limits.

Refer to the Airbus Helicopters maintenance manuals for inspection of the cargo hook kit's aircraft interface including the beam and the fixed provisions of the cargo hook release systems.

Annually or 100 hours of external load operations, whichever comes first, inspect the cargo hook kit per this section.



Hours of external load operations should be interpreted to be (1) anything is attached to the primary cargo hook (whether or not a useful load is being transported) and (2) the aircraft is flying. If these conditions are NOT met, time does NOT need to be tracked.

For each of the following, repeat for the second cargo hook if the dual cargo hook kit is installed.

1. Check the function of the cargo hook's electrical release system per the following,
 - With no load on the cargo hook, press Cargo Release switch on the cyclic, the cargo hook load beam should fall to the open position.
 - Manually return the load beam to the closed position and verify that each one latches and the hook lock indicator is aligned with the engraved lines on the outside of the cargo hook (see Figure 5.1.1).
2. Check the function of the cargo hook's manual release system per the following.
 - With no load on the cargo hook, pull each lever on the collective, the cargo hook load beams should fall to the open position.
 - Manually return the load beam to the closed position and verify that it latches and the hook lock indicator is aligned with the engraved lines on the outside of the cargo hook. Use an inspection mirror and/or light to see the hook lock indicator.

	Instructions for Continued Airworthiness	Document Number 123-053-00	Revision 1
		Date 04/15/2022	Page 14 of 38

Figure 5.1.1 Hook Lock Indicator





3. Visually inspect the external electrical harness and its connectors for damage and security.
4. Visually inspect the external manual release cable and its connections for damage and security.

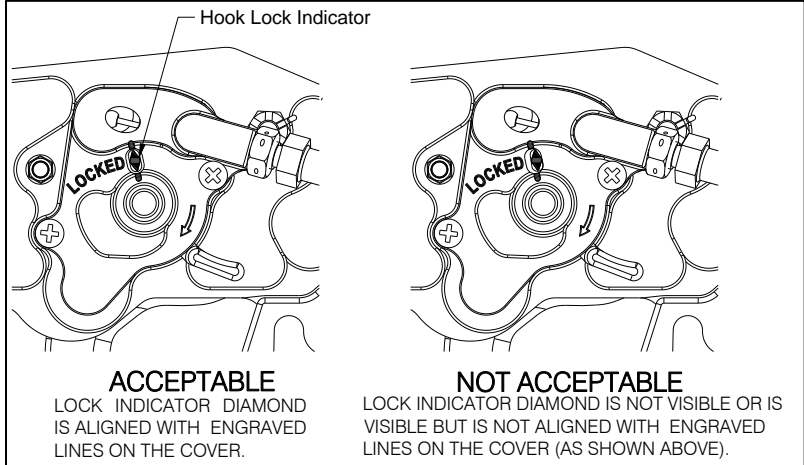

Manual release cables are wearable items and must be replaced as condition requires. Broken or kinked conduit, inner cable kinks (ref. Figure 5.1.2), frays, or sticky operation are each cause for immediate replacement.

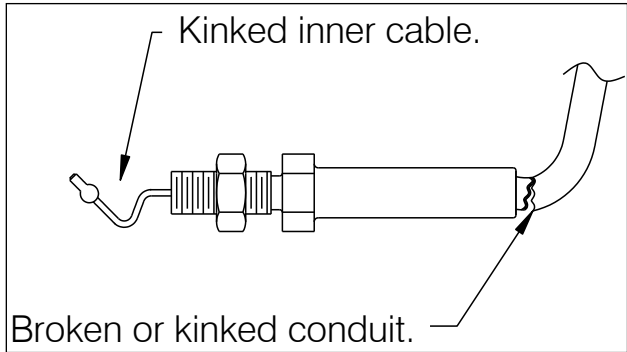
Figure 5.1.2 Examples of Manual Release Cable Damage



	Instructions for Continued Airworthiness	Document Number 123-053-00	Revision 1
		Date 04/15/2022	Page 15 of 38

5. Check the manual release cable rigging per the following. Note: rigging must be checked with the manual release cover on as the manual release cable is threaded into the cover.

Rotate the manual release lever clockwise to remove the free play (the free play is taken up when the hook lock indicator begins to move, this is also readily felt as the lever rotates relatively easily for several degrees as the free play is taken up) and hold it in this position while checking the gap between the release lever fork fitting and the cable ball end as shown below. Check that there is a minimum gap of .13 inches (3.2 mm) as shown in Figure 5.1.3. Detail A in this figure hides the cover to show the fork fitting and its interaction with the release cable.



The load beam must be closed and locked when checking the gap with manual release cable.

Figure 5.1.3 Manual Release Cable Rigging Check

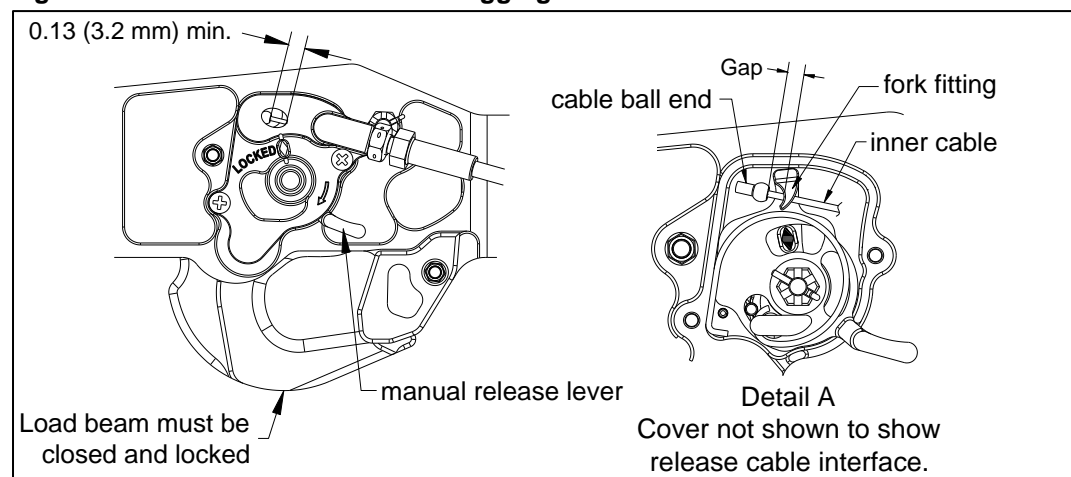

6. If the dual cargo hook kit is installed, inspect for security of the manual release cable in the forward hook compartment as it passes through from the aft cargo hook, i.e. – ensure that it is secured clear of and cannot contact the forward cargo hook including its manual release lever.
7. Rotate the cargo hook laterally through its range of motion and ensure it pivots freely and that its electrical harness and manual release cable are not pulled tight in any position and are not pinched or chafed.
8. Visually inspect cargo hook for presence and security of fasteners.
9. Visually inspect the cargo hook housing and load beam for corrosion, cracks and damage. If damage is observed refer to the cargo hook CMM for limits.

	Instructions for Continued Airworthiness	Document Number 123-053-00	Revision 1
		Date 04/15/2022	Page 16 of 38

5.2 Long Line Kit Inspection

Inspection of the long line kit includes a check before each use (not a maintenance activity) and an annual inspection. **Refer also to the manufacturer's Long Line User Manual. All of the manufacturer's inspection requirements must be observed.**



Items 1.1, 2, 3, 5, and 6 are critical safety items. Unauthorized repairs or modifications of these parts may have hazardous consequences.



For critical safety items, practice careful handling and protection against damage during handling and inspection.

The following figure shows the components of the long line kit P/N 200-476-XX. The Y-rope (item 1, 1.1) interfaces with the dual cargo hooks and is the only required component of the long line kit for carrying of HEC. For items connected below the Y-rope, locally approved alternate configurations may be used. If an alternate configuration is used refer to its maintenance documentation.

Figure 5.2.1 Long Line Kit

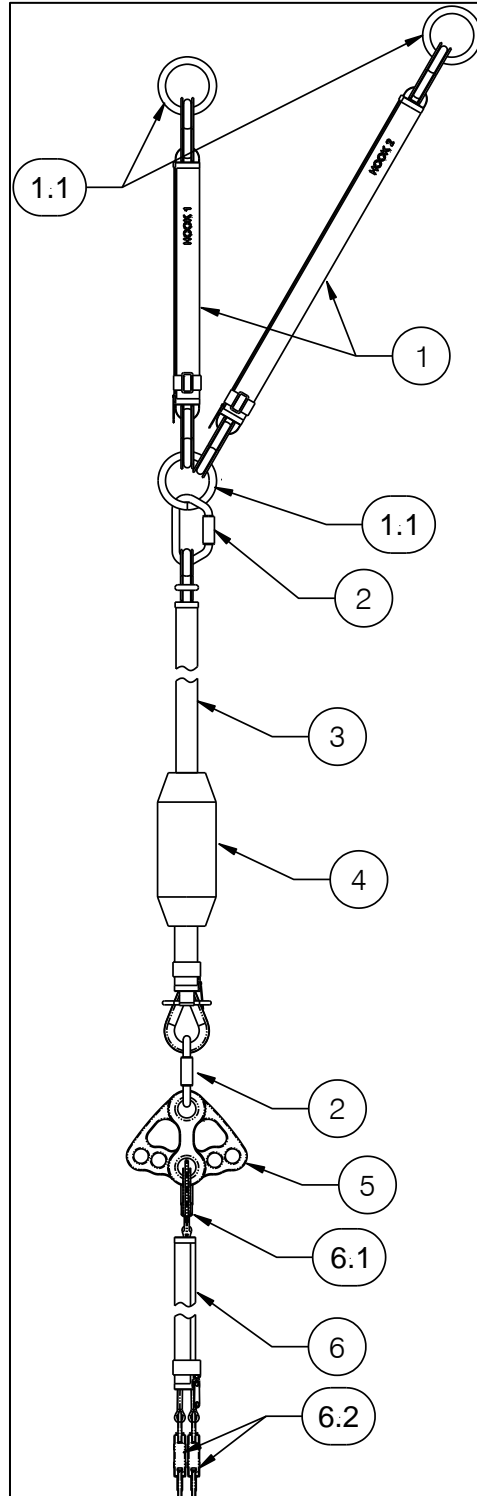

	Instructions for Continued Airworthiness	Document Number 123-053-00	Revision 1
		Date 04/15/2022	Page 18 of 38

Table 5.1 Long Line Kit Components

Item	Part No.	Description	Qty
1	490-022-00	Y-rope	1
1.1	N/A**	Load Ring	3
2	530-031-00	Carabiner	2
3	490-023-XX*	Long Line	1
4	490-017-00	Weight Bag, 25 lb.	1
5	292-107-00	Rigging Plate	1
6	490-018-00	Lanyard	1
6.1	N/A**	Carabiner (Lanyard)	1
6.2	N/A**	Snap Hook (Lanyard)	2

*Long Line P/N is completed by replacing the "XX" with the length divided by 10, for example a 100-foot long line is P/N 490-023-10 and a 150-foot long line is P/N 490-023-15, etc.

**The Load Rings (1.1), Carabiner (6.1) and Snap Hooks (6.2) are integral to the Y-rope and Lanyard respectively.

Prior to a flight involving external load operations that includes use of long line kit components check the condition of the equipment and check the condition of the equipment after each use.

Use the criteria defined in the annual inspection as a guide for the check. Also, consult the Long Line User's Manual provided by the rope manufacturer.

	Instructions for Continued Airworthiness	Document Number 123-053-00	Revision 1
		Date 04/15/2022	Page 19 of 38

Annually inspect the long line kit components per the following.

Inspection of the Y-rope (1), Long Line (3), and Lanyard (6) must be conducted by a qualified person. In addition to the instructions below, consult the Long Line User's Manual provided by the rope manufacturer.

5.2.1 Y-rope Inspection

Inspect the Y-rope (1) per the following.

1. Open the covers and inspect them on the inside and outside per the following.
 - Loose, cut or pulled zipper stitching.
 - Torn, cut or otherwise damaged cover material.
 - Legibility and security of "HOOK 1" and "HOOK 2" ID tags.
 - Condition and function of zipper.
 - Condition of strap and buckle at each end of cover.
 - Condition and function of hook and loop closure strap.
 - Legibility and security of ID tag.

2. Inspect each length of rope and the end terminations of the rope per the following.
 - Security of thimble, verify it is securely captured by the eye splice.
 - Condition of thimbles, inspect for signs of damage including corrosion, cracks, distortion, nicks, or rough surfaces.
 - Condition of the rope's lockstitch thread and whipping thread at each eye splice, inspect for broken, cut or frayed threads.
 - Legibility and security of ID tag.
 - Externally observed abrasion, cut strands or areas of extensive fiber breakage.
 - Fiber breakage, fused or melted fibers observed internally (observed by prying or twisting to open the strands). Remove from service if an estimated 10% of fiber in any strand or the rope as a hole is damaged.
 - Uniform fiber breakage along the length of rope such that the entire rope appears covered with fuzz or whiskers.

	Instructions for Continued Airworthiness	Document Number 123-053-00	Revision 1
		Date 04/15/2022	Page 20 of 38

- Consistent diameter of the ropes. Measure the rope diameter in several locations and inspect for flat areas, bumps, or lumps. Remove from service if the diameter has been reduced by more than 10% in any area.
- Discoloration, brittle fibers and hard or stiff areas that may indicate chemical, ultraviolet or heat damage.
- Melted, hard or charred areas which may be evidence of excessive heat. Remove from service if areas in this condition affect more than 10% of the rope diameter or affect several adjacent strands along the length that affect more than 10% of strand diameters.
- Cleanliness of the ropes, stiffness of the ropes may indicate dirt or grit embedded within their fibers.
- Wear on Load Ring, inspect per criteria in Table 5.2.

5.2.2 Long Line Inspection

Inspect the Long Line (3) per the following.

Lay out the long line on a clean surface as it should be thoroughly inspected both visually and by feel over its entire length.

1. Unzip the cover and inspect it inside and outside per the following.
 - Loose, cut or pulled zipper stitching
 - Torn, cut or otherwise damaged loops (attaching each end of cover to thimbles).
 - Torn, cut or otherwise damaged cover material.
 - Condition and function of zipper.
 - Condition and function of hook and loop closure strap.
2. Inspect the rope and end terminations of the Long Line for the following.
 - Security of thimble, verify it is securely captured by the eye splice.
 - Condition of thimbles, inspect for signs of damage including corrosion, cracks, distortion, nicks, or rough surfaces.
 - Condition of the rope's lockstitch thread and whipping thread at each eye splice, inspect for broken, cut or frayed threads.
 - Legibility and security of ID tag.

	Instructions for Continued Airworthiness	Document Number 123-053-00	Revision 1
		Date 04/15/2022	Page 21 of 38

3. Along the entire length of the rope, inspect for the following.
 - Externally observed abrasion, cut strands or areas of extensive fiber breakage.
 - Fiber breakage, fused or melted fibers observed internally (observed by prying or twisting to open the strands). Remove from service if an estimated 10% of fiber in any strand or the rope as a hole is damaged.
 - Uniform fiber breakage along the length of rope such that the entire rope appears covered with fuzz or whiskers.
 - Consistent diameter of the rope. Measure the rope diameter in several locations and inspect for flat areas, bumps, or lumps. Remove from service if the diameter has been reduced by more than 10% in any area.
 - Discoloration, brittle fibers and hard or stiff areas that may indicate chemical, ultraviolet or heat damage.
 - Melted, hard or charred areas which may be evidence of excessive heat. Remove from service if areas in this condition affect more than 10% of the rope diameter or affect several adjacent strands along the length that affect more than 10% of strand diameters.
 - Cleanliness of the rope, stiffness of the rope may indicate dirt or grit embedded within its fibers.

5.2.3 Lanyard Inspection

Inspect the Lanyard (6) per the following.

1. Unzip the cover and inspect the inside and outside per the following.
 - Loose, cut or pulled zipper stitching
 - Loose, cut or pulled stitching of cover to webbing.
 - Torn, cut or otherwise damaged cover material.
 - Condition and function of zipper.
 - Condition and function of hook and loop closure strap.
2. Inspect the load carrying webbing material of the Lanyard Assembly for the following.
 - Legibility and security of ID tag.
 - Acid or caustic burns.
 - Holes, tears, cuts or snags.

	Instructions for Continued Airworthiness	Document Number 123-053-00	Revision 1
		Date 04/15/2022	Page 22 of 38

- Broken or worn stitching in the load bearing splices.
 - Excessive abrasive wear.
 - Knots in any part of the sling.
 - Discoloration and brittle or stiff areas on any part of the sling.
3. Inspect the captive carabiner and the two snap hooks of the Lanyard Assembly per Table 5.2.

	Instructions for Continued Airworthiness	Document Number 123-053-00	Revision 1
		Date 04/15/2022	Page 23 of 38

Carefully inspect detail parts in accordance with the instructions in Table 5.2. Inspect the parts in a clean, well-lighted room using standard dimensional measuring tools and visual methods. Repair parts found within inspection limits. Replace any part found beyond limits.

Table 5.2 Inspection Criteria for Long Line Kit

Seq	Component	Inspection Criteria and Limit	Repair Action	Finish
1.	Load Ring (1.1, integral to Y-rope Assembly)	Wear on inside of ring – minimum thickness of cross section of ring - 0.50 in. (12.7 mm)	Blend at 10:1 ratio as required to provide smooth transitions.	N/A
2.	Carabiner (2)	Nicks, dents, scratches, corrosion – 0.020 in. (0.127 mm) deep	Blend at 10:1 ratio as required to provide smooth transitions.	N/A
		Proper engagement of latching mechanism, 3-stage opening action should be free of any binding that may be an indication of deformation.	None.	N/A
3.	Rigging Plate (3)	Nicks, dents, scratches, corrosion – 0.020 in. (0.127 mm) deep	Glass bead blast at less than 30 PSI to remove corrosion.	Passivate per AMS-QQ-P-35 or ASTM A967
		Wear on inside diameter of holes for attachment to long line and loads. – See Figure 5.2.2.	None.	N/A
4.	Carabiner (6.1, integral to Lanyard)	Nicks, dents, scratches, corrosion – 0.020 in. (0.127 mm) deep.	Blend at 10:1 ratio as required to provide smooth transitions.	N/A
		Proper engagement and operation of latching mechanism, 3-stage opening action should be free of any binding that may be an indication of deformation.	None.	N/A
5.	Snap Hook (6.2, integral to Lanyard)	Nicks, dents, scratches, corrosion – 0.020 in. (0.127 mm) deep	Blend at 10:1 ratio as required to provide smooth transitions.	N/A
		Proper engagement and operation of gate mechanism, 2-stage opening action should be free of any binding that may be an indication of deformation.	None.	N/A

Figure 5.2.2 Rigging Plate Inspection Criteria

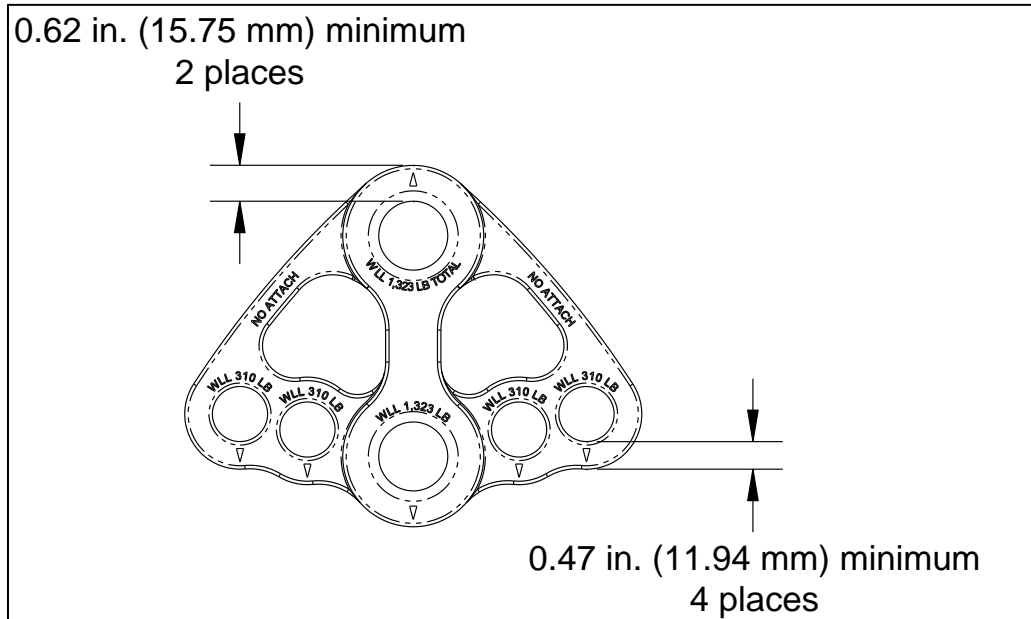

	Instructions for Continued Airworthiness	Document Number 123-053-00	Revision 1
		Date 04/15/2022	Page 25 of 38

5.3 Cargo Hook Overhaul

Time Between Overhaul (TBO) for the cargo hook: 1000 hours of external load operations or 5 years, whichever comes first.



Overhaul instructions for the cargo hook are contained in CMM 122-036-00. Contact Onboard Systems for guidance to locate authorized overhaul facilities.

	Instructions for Continued Airworthiness	Document Number 123-053-00	Revision 1
		Date 04/15/2022	Page 26 of 38

Section 11 Placards and Markings



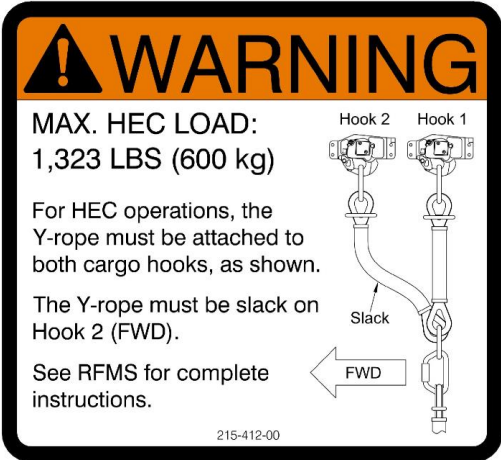

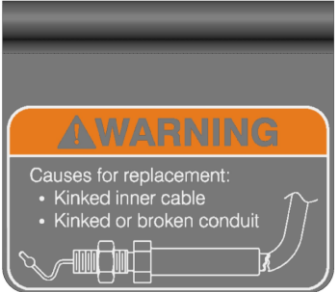
The following placards are included with the cargo hook kits

Table 11.1 Placards

Placard part number (P/N) and appearance	Location
<p>P/N 215-412-00</p> 	<p>Applicable to dual cargo hook installation only: on side of cargo hook beam or on belly of helicopter adjacent to the cargo hook beam.</p>
<p>P/N 215-272-00</p> <p>One side:</p>  <p>Opposite side:</p> 	<p>On the manual release cable, near the connection at the belly.</p>

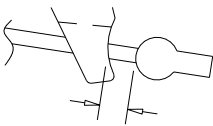
continued

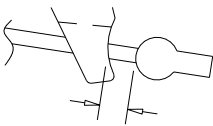
	Instructions for Continued Airworthiness	Document Number 123-053-00	Revision 1
		Date 04/15/2022	Page 27 of 38

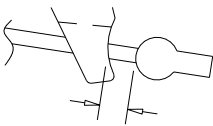
Placard part number (P/N) and appearance	Location		
<p style="text-align: center;">P/N 215-240-00</p> <table border="1" style="width: 100%; border-collapse: collapse;"> <tr> <td style="width: 50%; padding: 5px;">  WARNING Inadvertent loss of load can result from improper cable adjustment. See manual for complete instructions. </td> <td style="width: 50%; padding: 5px; text-align: center;">  .13 in / 3.2 mm min </td> </tr> </table>	 WARNING Inadvertent loss of load can result from improper cable adjustment. See manual for complete instructions.	 .13 in / 3.2 mm min	<p>Located on the bottom side of the cargo hook (on the electrical solenoid side).</p>
 WARNING Inadvertent loss of load can result from improper cable adjustment. See manual for complete instructions.	 .13 in / 3.2 mm min		

	Instructions for Continued Airworthiness	Document Number 123-053-00	Revision 1
		Date 04/15/2022	Page 28 of 38

Section 25 Equipment and Furnishings

25.5 Component Weights and CG

The weight and cg of the cargo hook kit components are listed in the table below.

Table 25.1 Component Weights and CGs

Item	Weight	Station
Cargo Hook (Hook 1)	3.7 lbs (1.68 kg)	165.4 in. (4200 mm)
Cargo Hook (Hook 2)	3.7 lbs (1.68 kg)	153.7 in. (3905 mm)
Electrical Harnesses (2)	0.5 lbs (0.23 kg)	*
Manual Release Cables (2)	1.0 lbs. (0.45 kg)	*

* The weight of the external electrical harnesses and manual release cables is evenly distributed from the Cargo Hooks to the connector panel on the belly.

25.12 Storage Instructions

Refer to the CMM 122-036-00 for Cargo Hook storage instructions. For storage of the long line kit ropes, consult the Long Line User's Manual provided by the rope manufacturer.



The components of the long line kit are critical safety items. Practice careful handling and protection against damage and corrosion (metallic parts) during storage.

	Instructions for Continued Airworthiness	Document Number 123-053-00	Revision 1
		Date 04/15/2022	Page 29 of 38

25.15 Trouble Shooting

Table 25.2 is provided with the intention of isolating the cause of malfunctions within the system. Sections 25.16 and 25.17 include instructions for removing and replacing defective components.

Table 25.2 Trouble Shooting

Malfunction	Probable Cause	Corrective Action						
Cargo hook does not operate electrically or manually.	Defective internal mechanism or corroded and seized mechanism pivot bushings/bearings.	Remove and replace cargo hook (see sections 25.16 and 25.17) or repair per Cargo Hook Component Maintenance Manual (CMM) no. 122-036-00.						
Cargo hook does not open with electrical release, opens with manual release.	Open electrical circuit, faulty wiring, circuit breaker, relay, switch or solenoid.	<p>Using multi-meter, check the resistance between pins A and B of electrical connector. If open indication is obtained, remove and replace cargo hook (see sections 25.16 and 25.17) or repair per Cargo Hook Component Maintenance Manual (CMM) no. 122-036-00. Check the aircraft circuit for opens and shorts by using a multi-meter on the connector. When the release switch is pressed 28V (aircraft voltage) should be present on the connector pins. The pin-out for the connector is as follows.</p> <table border="1" data-bbox="824 1094 1062 1203"> <thead> <tr> <th>Pin</th> <th>Function</th> </tr> </thead> <tbody> <tr> <td>A</td> <td>Ground</td> </tr> <tr> <td>B</td> <td>Power</td> </tr> </tbody> </table> <p>Cargo hook's electrical release system interfaces with the TC installed internal wiring, refer to the Airbus maintenance manual for the aircraft for this information.</p>	Pin	Function	A	Ground	B	Power
Pin	Function							
A	Ground							
B	Power							
Cargo hook operates electrically, but not manually.	Kinks in manual release cable or broken conduit.	<p>Inspect external* manual release cable and its connection to the Cargo Hook and at the connection point on the belly. Remove manual release cover on cargo hook and inspect inner cable connection to cargo hook. Remove and replace cargo hook or external manual release cable (see Sections 25.16 and 25.17) or repair Cargo Hook per its CMM.</p> <p>*These kits interface with the TC installed internal manual release cables including the release levers on the collective. Refer to the Airbus maintenance manual for these internal components.</p>						
Load beam fails to re-latch after being reset.	Defective internal mechanism.	Remove and replace cargo hook (see sections 25.16 and 25.17) or repair per Cargo Hook Component Maintenance Manual (CMM) no. 122-036-00.						
Manual release cable pull force exceeds 8 lbs. (35.6 N) at the cargo hook.	Friction in internal mechanism.	Remove and replace cargo hook (see Section 25.16 and 25.17).						

	Instructions for Continued Airworthiness	Document Number 123-053-00	Revision 1
		Date 04/15/2022	Page 30 of 38

25.16 Component Removal

25.16.1 Cargo Hook Removal

The instructions in this section are applicable to the cargo hooks of the Dual Cargo Hook Kit (P/N 200-467-00) and the Single Cargo Hook Kit (P/N 200-375-01). If the Single Cargo Hook Kit is installed, the references to the forward cargo hook (Hook 2) are not applicable.

1. Remove the nuts (Airbus P/N 8PH135M) and washers (Airbus P/N 2311180AGL) from each bolt (Airbus P/N 22733BC100 047M) securing the Forward Bearing Housing (Airbus P/N AS22-38-20-02) and Aft Bearing Housing (Airbus P/N AS22-38-20-03) to the beam brackets. Lower the cargo hook enough to access its manual release cover screws.

Figure 25.16.1 Cargo Hook Removal

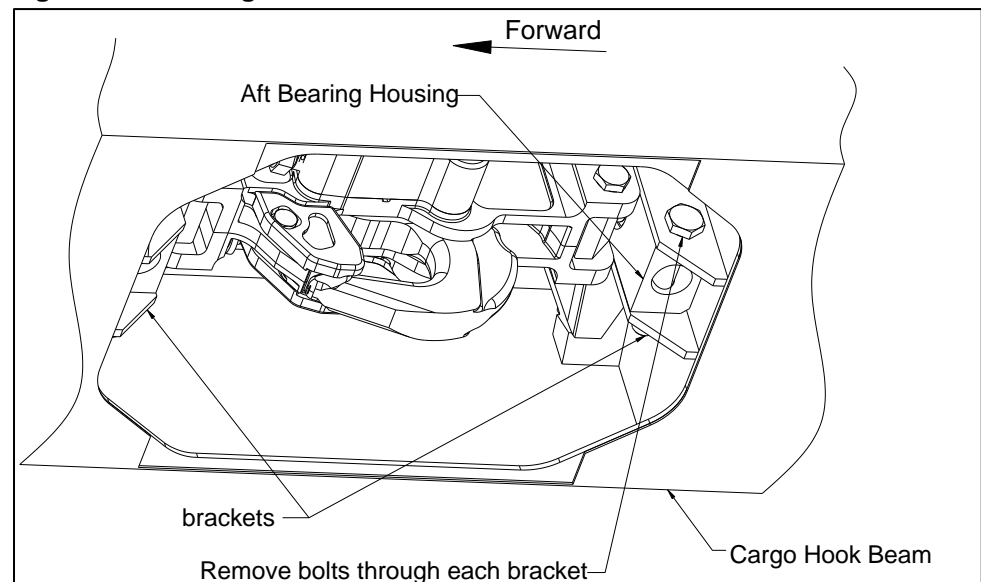

2. Remove the two manual release cover screws (reference Figure 25.16.2) and unhook the inner cable of the manual release cable and remove the cargo hook from the Cargo Hook Beam.
3. Loosen the jam nut on the manual release cable and unthread the manual release cover from the end of the release cable fitting.

Figure 25.16.2 Manual Release Cover Removal

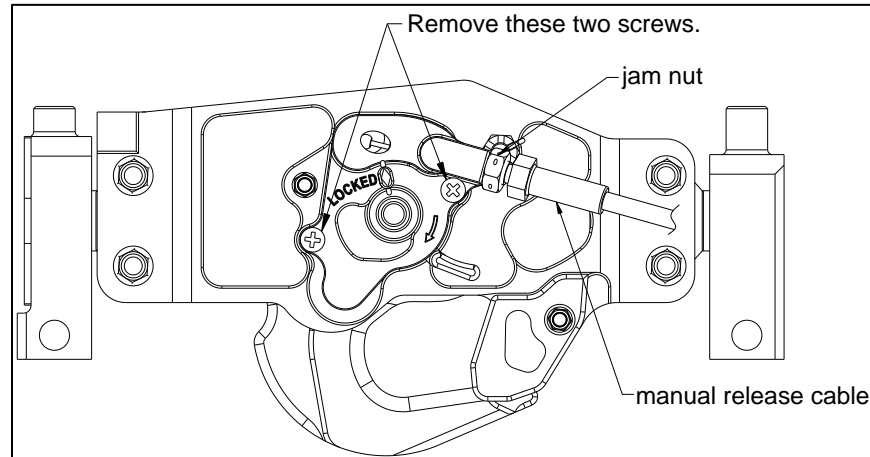

4. Cut safety wire and disconnect the electrical harness connector at the cargo hook and remove the cargo hook from the beam.
5. Loosely re-assemble the manual release cover onto the cargo hook to retain it.
6. Separate the Forward Bearing Housing (Airbus P/N AS22-38-20-02) from the Forward Pivot (Airbus P/N AS22-38-20-04) by sliding it off (ref. Figure 25.16.3).

Figure 25.16.3 Forward Bearing Housing

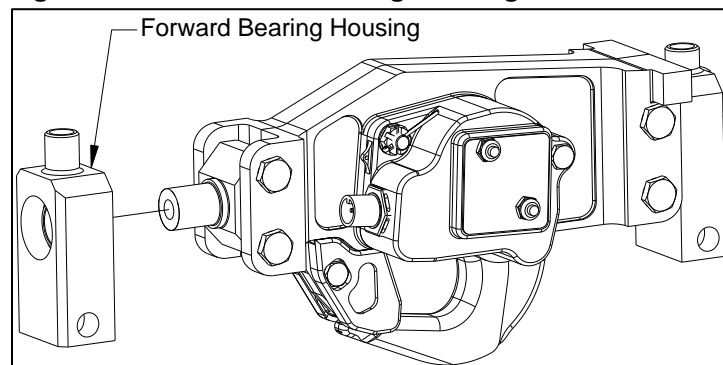

7. Remove the Forward Pivot and Aft Pivot (Airbus P/N AS22-38-20-05) with Aft Bearing Housing from the cargo hook by removing the two nuts (Airbus P/N 8PH135M) and bolts (Airbus P/N 22201BC080044L) securing each of them, reference Figure 25.16.4.

	Instructions for Continued Airworthiness	Document Number 123-053-00	Revision 1
		Date 04/15/2022	Page 32 of 38

Figure 25.16.4 Bearing Housing and Pivot Removal



NOTICE

The bolts, nuts, Forward and Aft Pivots, and Forward and Aft Bearing Housings are as provided under the Airbus Helicopters' type certificate. Refer to the applicable Airbus documentation for maintenance information for these parts.

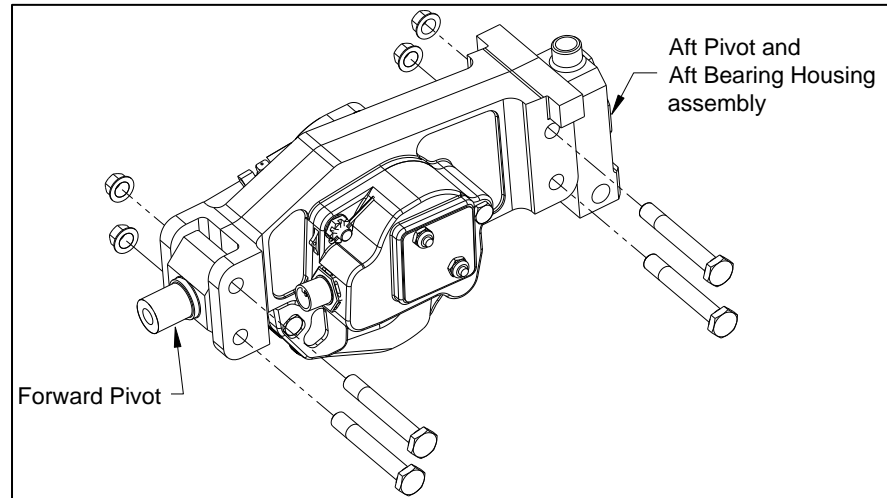
25.16.2 Manual Release Cable Removal

1. Remove the manual release cable from the cargo hook as described in the previous section.
2. Remove the aft cargo hook (Hook 1) manual release cable from the loop clamp on the inside wall of the forward cargo hook bay (this applies to the dual cargo hook installation only).
3. Remove the manual release cables from the Airbus clamp at the hole in the bottom of the beam just forward of the forward cargo hook (Hook 2).
4. At the connector panel on the belly of the helicopter, disengage the locking pin securing the Adapter Fitting.
5. Unthread the Adapter Fitting to access and separate the inner cable of the manual release cable from the fixed manual release cable.

	Instructions for Continued Airworthiness	Document Number 123-053-00	Revision 1
		Date 04/15/2022	Page 33 of 38

25.17 Component Re-installation

25.17.1 Cargo Hook Re-installation

Re-assemble the Forward Pivot and Aft Pivot/Aft Bearing Housing assembly onto each cargo hook (refer to Figure 25.16.4). Tighten to nuts to 2 daN-m (170-177 in-lbs).

1. Connect the longer electrical release harness (P/N 270-298-00) connector to the aft cargo hook (Hook 1) and the shorter electrical release harness (P/N 270-299-00) connector to the forward cargo hook (Hook 2).
2. Safety wire the electrical release harness connector to the cargo hook (to the adjacent tab on the cover).

Connect the manual release cable to the cargo hook per the following. The longer manual release cable (P/N 268-059-00) is attached to the aft cargo hook (Hook 1) and the shorter manual release cable (P/N 268-060-00) is connected to the forward cargo hook (Hook 2).

3. Remove the manual release cover from the cargo hook by removing the two cover screws (see below).

Figure 25.17.1 Manual Release Cover Removal

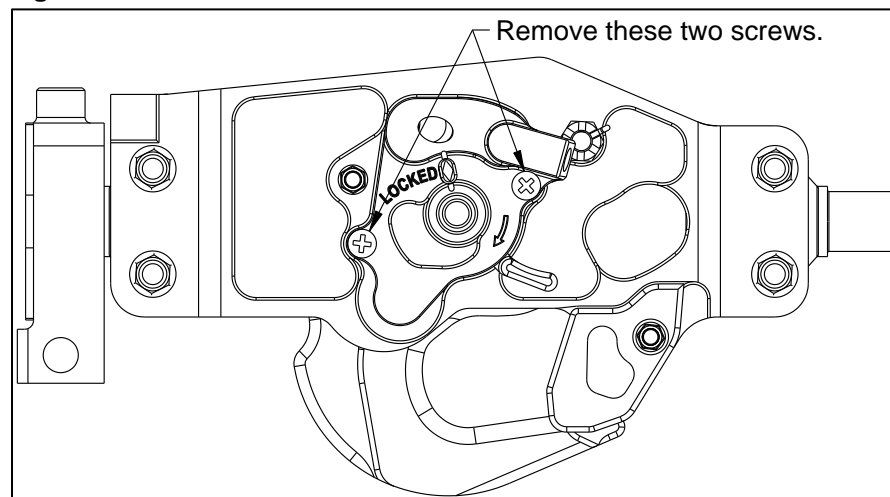

4. Thread the manual release cover onto the end fitting of the manual release cable until it is about .38 inches (9.6 mm) from the inside of the hex feature on the fitting (as shown below). Lightly tighten the jam nut at this point, the release cable may need to be adjusted later.

Figure 25.17.2 Release Cable Setting

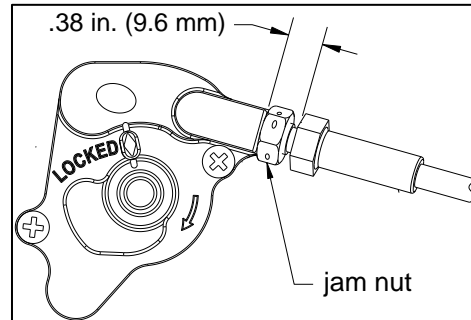

5. Hold the manual release cover near the cargo hook, position the inner cable of the manual release cable within the fork fitting as shown below.

Figure 25.17.3 Inner Cable Positioning

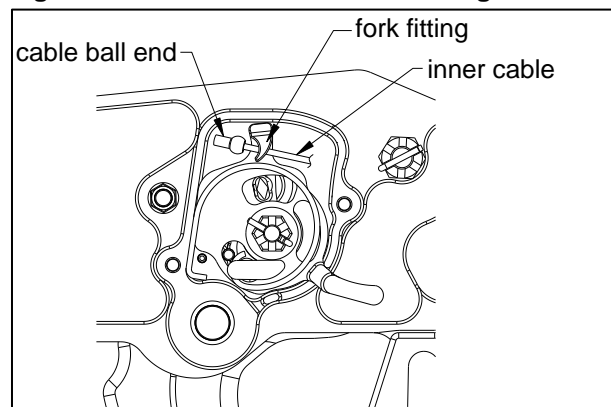

6. Secure the manual release cover to the cargo hook with the two screws.
7. Before positioning the cargo hook within the bay, slide the Forward Bearing Housing Assembly over the Forward Pivot (ref. Figure 25.16.3)
8. Insert this assembly up into the respective brackets on the beam (ref. Figure 25.17.4). Insert the Airbus bolts through to hold the cargo hook in place and secure with nuts. Torque the nuts to 3.2 daN-M (270-283 in-lbs).

Figure 25.17.4 Cargo Hook Installation within Beam

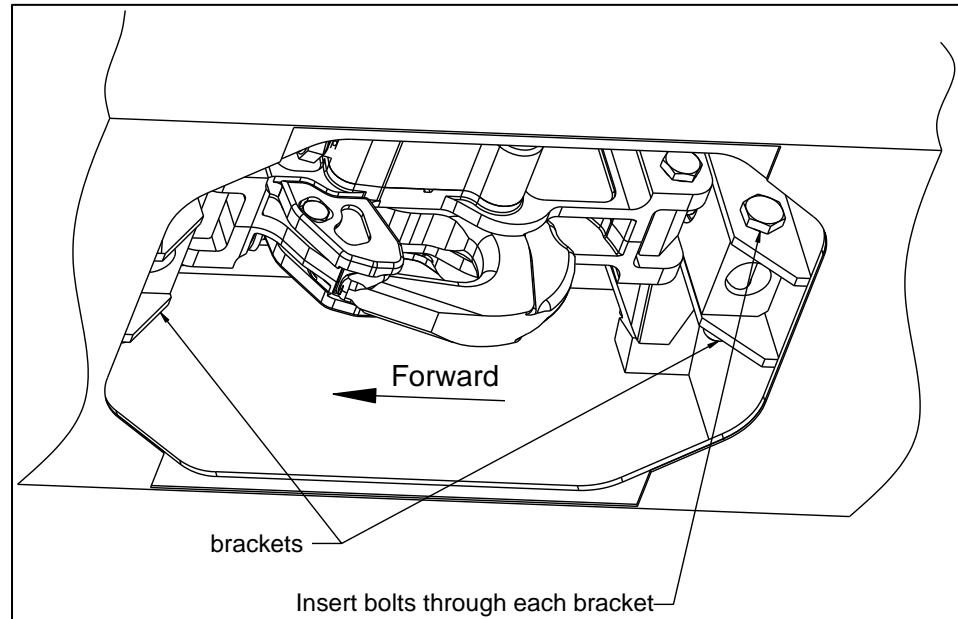

	Instructions for Continued Airworthiness	Document Number 123-053-00	Revision 1
		Date 04/15/2022	Page 36 of 38

25.17.2 Manual Release Cable Re-installation



Un-commanded cargo hook release can occur if the manual release cable is improperly restrained. The cable must not be the stop that prevent the Cargo Hook from rotating side to side. If the Cargo Hook loads cause the cargo hook to strain against the manual release cable the swaged end of the cable may separate allowing the inner cable to activate the cargo hook manual release mechanism. The result is an un-commanded release.

Connect the manual release cable to the cargo hook per the previous section. If the cargo hook is installed, remove the bolt securing the aft bearing housing to the bracket to pivot the cargo hook downward to access the manual release cover screws with a screwdriver.

Connect the manual release cables from Hook 1 and Hook 2 to the respective fixed manual release cables on the connector panel per the following.

1. Retract the Adapter Fitting of the manual release cable and connect the Cable End Fittings. For the dual cargo hook installation, the Cable End Fittings are sized differently so that they cannot be incorrectly mated (i.e. - Hook 1 release cable can't physically be connected to the fixed release cable for Hook 2).
2. Slide the Adapter Fitting up to and thread it over the existing fitting on the connector panel.
3. Secure the Adapter Fitting with the existing lock spring.

Figure 25.17.5 Manual Release Cable Connection at Panel

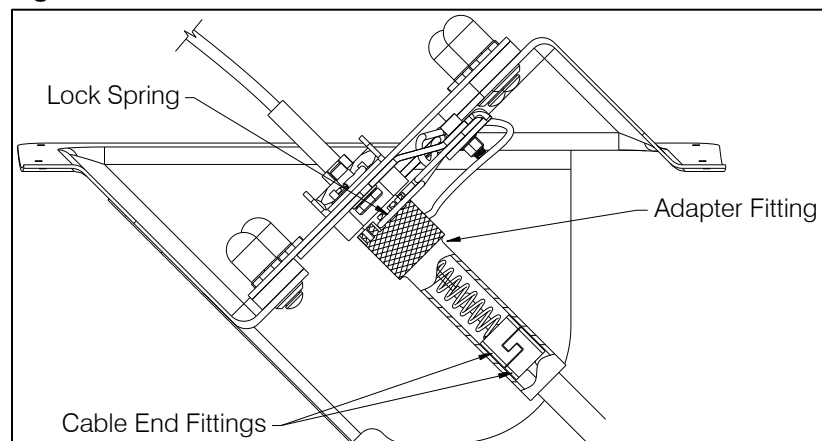

	Instructions for Continued Airworthiness	Document Number 123-053-00	Revision 1
		Date 04/15/2022	Page 37 of 38

Check the cable ball end free play at each cargo hook per the following.

4. With the cargo hook closed and locked, rotate the release lever in the clockwise direction to remove free play and hold (the free play is taken up when the hook lock indicator begins to move, this is also felt as the lever rotates relatively easily for several degrees as the free play is taken up).
5. Check the gap between the cable ball end and the fork fitting (ref. Figure 25.17.3 also) with the manual release lever in the cockpit in the non-release position. This gap must be a minimum of .125 inches (3.2 mm) as shown. If necessary, remove the bolt holding the Aft Bearing Housing Assembly in position and pivot the cargo hook downward for a better sight of the gap.



The load beam must be closed and locked when setting the gap with manual release cable.

Figure 25.17.6 Manual Release Cable Rigging Check

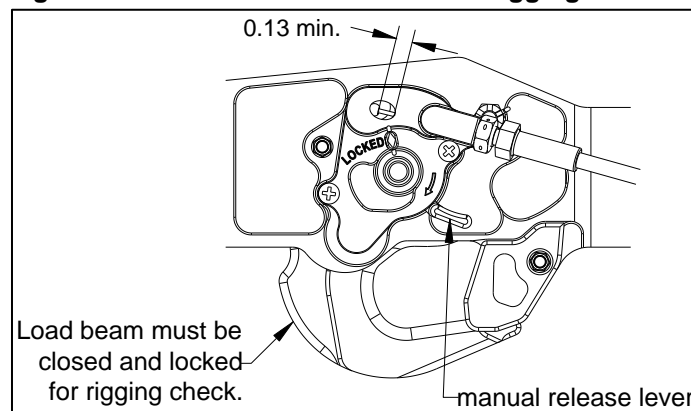

If necessary adjust the manual release cable system to obtain the minimum gap of .125 inches (3.2 mm) at the release lever fork fitting (the maximum gap is limited by the manual release cover). The system can be adjusted at the manual release lever on the collective (refer to Airbus Helicopters documentation) or adjustment can be made at the cargo hook per the following.

6. Remove the bolt through the Aft Bearing Housing Assembly to pivot the cargo hook downward enough to access the manual release cover screws.
7. Remove the two screws securing the manual release cover to the cargo hook and remove the cover.

	Instructions for Continued Airworthiness	Document Number 123-053-00	Revision 1
		Date 04/15/2022	Page 38 of 38

8. Loosen the jam nut and rotate the manual release cover clockwise to increase the gap. Referring to Figure 25.17.2, do not exceed a dimension of .56 inches (14 mm). If necessary to fit within the manual release cover, rotate the manual release cover CCW to back it out
9. Replace the manual release cover and verify the minimum gap of .125 inches (3.2 mm).
10. When satisfactory gap is present, securely tighten the manual release cover screws and the jam nut. Re-insert the bolts through the Forward and Aft Bearing Housing Assemblies (if removed).
11. Secure the bolts attaching the Forward and Aft Bearing Housing Assemblies to the beam brackets with the washers and nuts. Torque the nuts to 3.2 daN-M (270-283 in-lbs.).
12. Tighten the two nuts securing the two loop clamps to the studs in the forward bay (dual cargo hook installation only).
13. At the point where the release cables and electrical harnesses exit the bottom of the beam, secure within the existing Airbus clamp. Re-use the Airbus hardware.

25.18 General Procedural Instructions – Testing

After re-installation of a cargo hook, electrical release harness or manual release cable, perform the following.

1. Check the function of the cargo hook's electrical release system per the following,
 - With no load on the cargo hook, press Cargo Release switch on the cyclic. The cargo hook load beam should fall to the open position.
 - Manually return the load beam to the closed position and verify that it latches and the hook lock indicator is aligned with the engraved lines on the outside of the cargo hook (see Figure 5.1.1).
2. Check the function of the cargo hook's manual release system per the following.
 - With no load on the cargo hook, pull the lever on the collective. The cargo hook load beam should fall to the open position.
 - Manually return the load beam to the closed position and verify that it latches and the hook lock indicator is aligned with the engraved lines on the outside of the cargo hook.