



SERVICE BULLETIN

Document No. 159-023-00, Rev. 2

Date: September 10, 2015

**ONBOARD SYSTEMS
INTERNATIONAL**

13915 NW 3rd Court
Vancouver, WA 98685
USA

Phone: 360-546-3072

Fax: 360-546-3073

Toll Free: 800-275-0883

www.OnboardSystems.com

Subject: R44 Cargo Hook Suspension

Helicopters Affected: Robinson R44 and R44 II helicopters with Onboard Systems Cargo Hook Kit P/N's 200-227-00 or 200-313-00 installed per STC SR00578SE or 200-265-00 or 200-288-00 installed per STC SR01064SE.

Compliance: Recommended only for those cargo hook kits that are used to transport fertilizer spreaders or other loads with similar rotating tendencies. Implementation is recommended within 6 months of the release date (see above) of this Service Bulletin.

Description: The R44 cargo hook suspension system provides the means through which the cargo hook is attached to the aircraft. It includes a Pillow Block, Gimbal Assembly, and Link Assembly and associated hardware (refer to Figure 1 for visual identification of the configuration subject to this Service Bulletin). In April of 2007, an operator, during fertilizer bucket operations, experienced a failure of the Link Assembly (P/N 232-050-00). Time between overhaul restrictions were put in place for the suspension system when it is used for fertilizer bucket work or other operations where a torsional load is imparted into the suspension system. These restrictions were put in place until a re-designed suspension system was developed.

Solution: Onboard Systems has developed a new suspension system that includes a re-designed Gimbal Assembly, Link Assembly and Pillow Block. It is designed specifically to handle the repetitive torsion that fertilizer bucket type work induces. The new suspension system is directly interchangeable with the old suspension system thus is compatible with all of the Onboard Systems cargo hooks approved under these STCs.

This service bulletin is not compatible with cargo hook kit P/N's 200-228-00, 200-266-00, 200-289-00, and 200-314-00 which are equipped with a load cell. If in possession of these kits and using them with loads that impart rotational loading into the system, maintain them in accordance with their respective ICAs following the guidelines for rotating loads.

This Service Bulletin contains instructions for replacing the suspension system.

Approval: The engineering design aspects of this bulletin are FAA approved.

Manpower: Replacement of the components will require 1.0 man-hours. Man-hours are based on hands-on time and may vary with personnel and facilities available. No machining operations are required. Installation consists of removing and replacing parts.

Required Material: The following material is required for accomplishment of this bulletin and may be obtained from Onboard Systems:

Table 1. Required Materials

Material	Quantity
P/N 232-292-01 Suspension Assembly*	1

**Note: This Suspension Assembly supersedes P/Ns 232-292-00, 291-108-00 and 291-107-00 which were the original replacement parts for the parts subject to this Service Bulletin.*

Special Tools: None

Weight and Balance: The re-designed suspension system components weigh .35 lbs (.16 kgs) more than the components they replace.

Electrical Load Data: Not affected

References: None

Publications Affected:

Owner's Manual 120-077-00
Owner's Manual 120-097-00
Owner's Manual 120-111-00
ICA 123-005-00
ICA 123-016-00

Maintain the P/N 232-292-01 Suspension Assembly in accordance with ICA 123-030-00.

The latest Owner's Manuals are available through Onboard Systems' website at www.onboardsystems.com

Point of Contact: For additional assistance, contact Keys Miller at Onboard Systems. Phone: 360-546-3072 or 1-800-275-0883. Email: keys@onboardsystems.com.

Disposition of Parts Removed: Return removed parts to the factory.

Material/Part availability: Parts are available from Onboard Systems.

Accomplishment Instructions:

1. Suspension System Removal

It may be necessary to disconnect the electrical release harness and manual release cable from the Cargo Hook or optionally provide adequate support to the Cargo Hook after removal to avoid damaging or straining them.

1. Remove the hardware attaching the Cargo Hook to the Link Assembly and remove the Cargo Hook. Retain the cargo hook attach hardware.
2. Remove the safety wire from the cap screws and remove the cap screws to remove the pillow block and suspension assembly components (see Figure 1). Retain the cap screws.

Figure 1 Suspension Removal

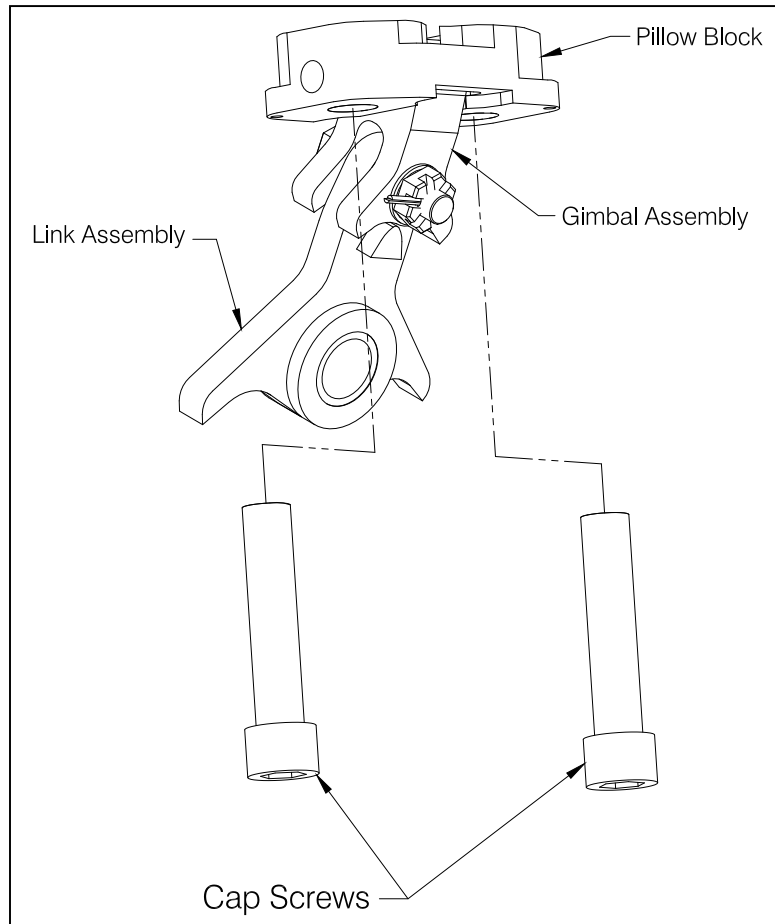

2. Replacement Component Installation

1. Apply sealant to the side of the Suspension Assembly (P/N 232-292-01) Pillow Block which is to be installed against the belly skin.
2. Orient the Suspension Assembly as shown in Figure 2.1.1 and secure it to the helicopter with the two P/N 290-505-00 or P/N 511-076-00 cap screws.

NOTICE

Install the Suspension Assembly so that the engraved "F" is forward and the engraved "A" is aft as shown in Figure 2.

3. Torque both cap screws to 26 ft-lbs.
4. Safety-wire the cap screws to the ears on the pillow block.
5. Re-install the cargo hook, re-using the hardware removed previously (see Figure 3).

Figure 2 Suspension Installation

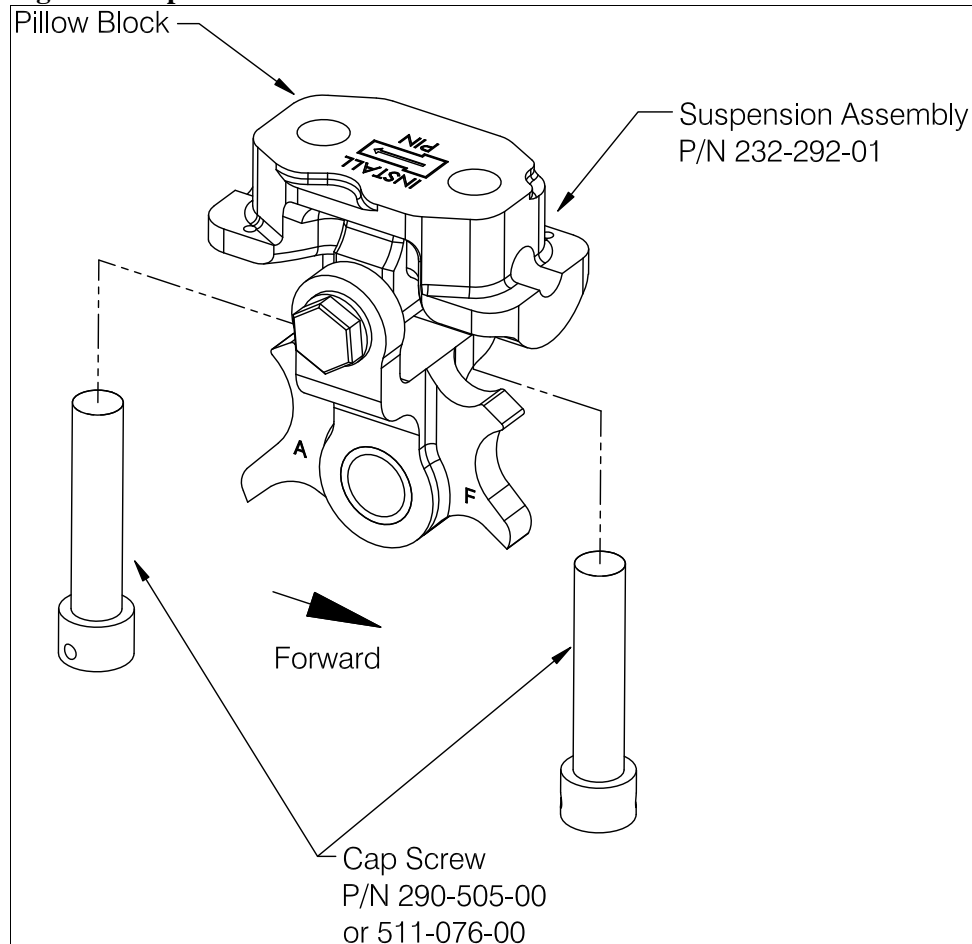

2. Replacement Component Installation continued

Figure 3 Cargo Hook Installation

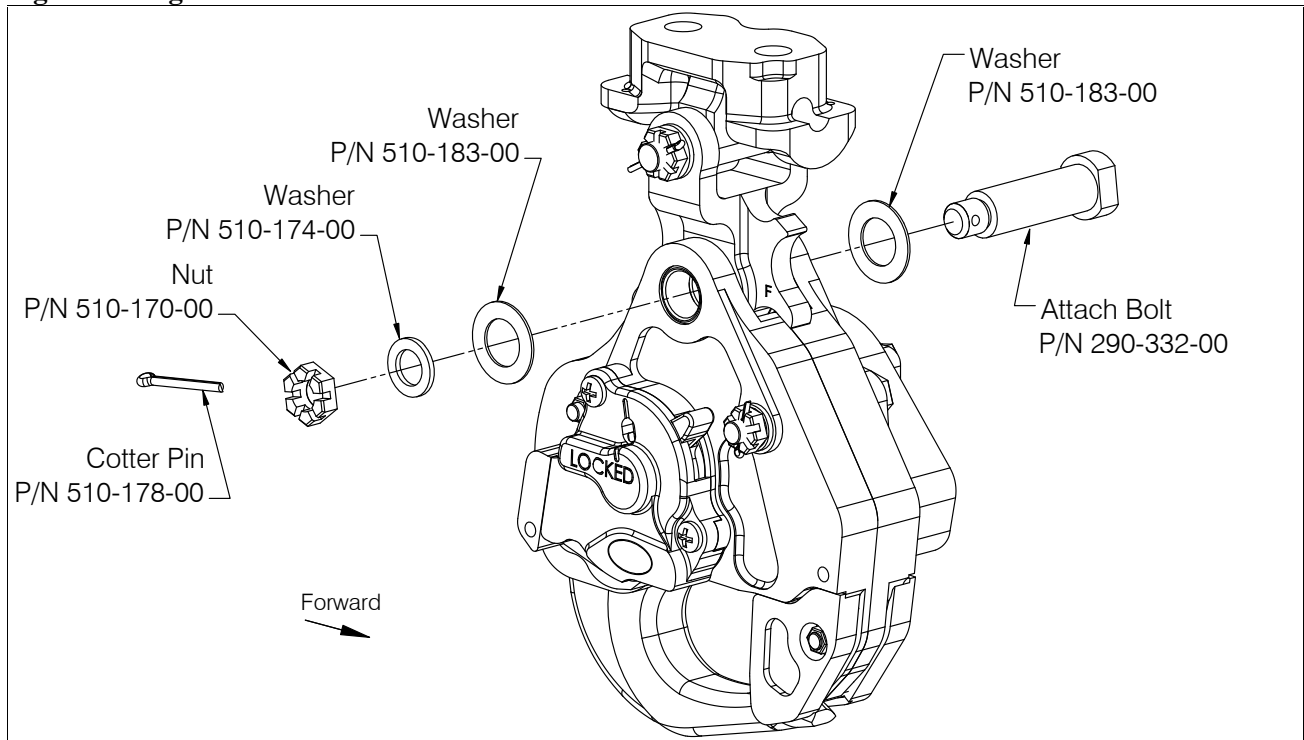

6. If removed, connect the manual release cable to the cargo hook and verify rigging per applicable Owner's Manual.
7. If removed, connect the electrical release harness connector to the cargo hook.
8. Swing the cargo hook and suspension system throughout their ranges of motion and verify that the manual release cable and electrical release harness have sufficient slack to accommodate this without being strained.
9. Make logbook entry.

SERVICE BULLETIN COMPLIANCE RECORD

R44 Cargo Hook Suspension System
Document No. 159-023-00, Revision 2

To help us monitor compliance with this Service Bulletin, please fill out and fax this form to (360) 546-3073.

<i>Company name:</i>	
<i>Date of SB compliance:</i>	
<i>Number of aircraft affected:</i>	
<i>Contact person:</i>	
<i>Address:</i>	
<i>City, State, Country:</i>	
<i>Telephone:</i>	
<i>Email:</i>	

<i>Comments:</i>

Revision History

Revision	Date	Reason for Revision
1	02/27/2008	Original Issue
2	09/10/2015	Revised to reflect current configuration of Suspension Assembly (P/N 232-292-01).