

SERVICE BULLETIN

Subject: Bell 206L/407 Manual Release Cable

Helicopters Affected: Bell 206L-1, 206L-3, 206L-4, and 407 model helicopters

Parts Affected: Manual Release Cable P/N 268-004-00 or 268-011-00. The applicable Cargo Hook Suspension kit or Onboard Weighing System part numbers and STC numbers which use this Manual Release Cable are as follows:

| Kit Number | STC Number |
|------------|------------|
| 200-040-xx | SH4935NM |
| 200-195-00 | SR00418SE |
| 200-196-00 | SR00418SE |
| 200-249-00 | SR00724SE |
| 200-250-00 | SR00724SE |
| 200-258-00 | SR00898SE |
| 200-259-00 | SR00898SE |
| 200-259-01 | SR00898SE |

Compliance: Recommended within 6 months of the issue date of this Service Bulletin.

NOTICE

A careful daily check of the manual release cable condition is recommended *both* before and after compliance with this bulletin.

Ownership: Please review this information and determine if the equipment is still in your possession. If this equipment is no longer in your possession, please forward this notice to the current owner or to your customer, as applicable.

Description: Onboard Systems has had reported cases of failure of the Manual Release Cable P/N 268-004-00. This cable is used to connect the release mechanism of the cargo hook to the fixed manual release cable as part of the backup release system (see Figure 1). Failure of the mechanical release cable can cause an uncommanded release.

Although no failures of Manual Release Cable P/N 268-011-00 have been reported, it is also recommended for replacement. The action(s) recommended by this service bulletin are described below.

Action: Two actions are required.

1) *Replace* Manual Release Cable P/N 268-004-00 *or* 268-011-00 with Manual Release Cable P/N 268-004-01. The redesigned Manual Release Cable incorporates more flexible conduit, improved end fittings, and increased length. These improvements extend the service life of the manual release cable.

2) Conduct daily pre-flight checks of the manual release cable and replace it as condition requires. A warning placard, P/N 215-272-00, is affixed to the current version of the 268-004-01 cable. The placard expresses the messages below and draws attention to the cable condition. *Careful cable inspection and timely replacement is essential to continued safe operation.*



Mechanical release cables are wearable items & must be replaced as condition requires.

As shown below, broken or kinked conduit, inner cable kinks, frays, or sticky operation are each cause for immediate replacement.

Check condition prior to each external load mission & replace as condition requires

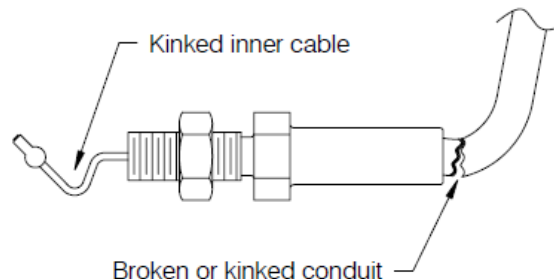



For safe operation of mechanical release cable-

- Route to avoid strain
- Rig with proper free play
- Replace as condition requires

Manpower: Inspection and Manual Release Cable replacement; approximately 1.5 man-hours will be required.

Required Materials: The following materials are required for accomplishment of this bulletin and may be obtained from Onboard Systems. Inspect your system before ordering the required materials.

If 268-004-01 is already installed-

Table 1 Required Materials

| Part Number | Description | Quantity |
|-------------|--------------------------------|----------|
| 215-272-00 | Manual Release Warning Placard | 1 |



If the 268-004-01 cable is already installed, only the addition of the warning placard is necessary.

If 268-004-01 is not installed-

Table 1 Required Materials

| Part Number | Description | Quantity |
|-------------|----------------------|----------|
| 268-004-01 | Manual Release Cable | 1 |



Special Tools: None

Weight and Balance: Not affected

Electrical Load Data: Not affected

References: None

Publications Affected: The following publications can be downloaded from our company website by visiting the following link:

http://www.onboardsystems.com/Support/Manuals_and_Documents.php

Owner's Manuals: 120-019-00, 120-046-00, 120-055-00, 120-085-00, 120-092-00. ICA(s): 123-007-00.

Contact Information: Technical support question regarding this bulletin can be addressed through the following contact methods:

Onboard Systems
13915 N.W. 3rd Court
Vancouver, WA 98685
USA

Phone: 360-546-3072
Fax: 360-546-3073
E-mail: techhelp@onboardsystems.com
Web: www.onboardsystems.com

Disposition of Parts Removed: Damaged cables are requested to be returned to the factory; Others should be destroyed on site.

Material/Part availability: Contact Onboard Systems for pricing and availability of replacement parts. Parts may be available at reduced cost during the compliance period. For applicable kits still under warranty, upgrade to the new manual release cable configuration will be at no cost FOB Vancouver WA USA.

Accomplishment Instructions: Replace the existing Manual Release Cable (P/N 268-004-00 or P/N 268-011-00) with the new Manual Release Cable (P/N 268-004-01) per the following instructions. The new cable can be identified by the part number marking on the cable housing.

Figure 1 Manual Release Cable (200-259-00 kit configuration shown)

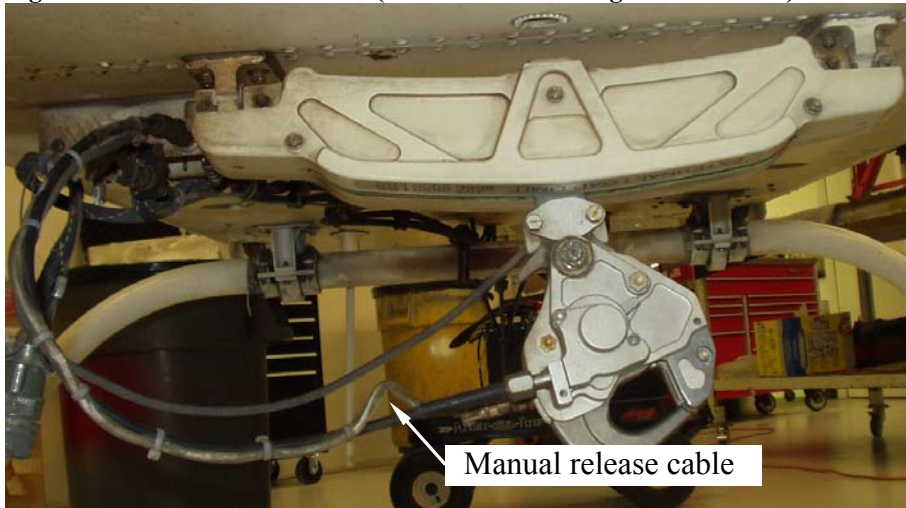

1. Visually inspect the Manual Release Cable to see if the new cable has already been installed. If the Manual Release Cable is marked "268-004-01", verify that the warning placard 215-272-00 is attached. If it is not, obtain the warning placard and affix it to the cable. If the Manual Release Cable is marked "268-004-00" or "268-011-00", then proceed to the next step.

Remove existing manual release cable

2. Disconnect the 268-004-00 Manual Release Cable from the fixed manual release cable at the spring loaded coupler at the bracket on the belly of the helicopter.
3. Remove the nut that secures the end fitting of the manual release cable to the bracket.

Figure 2 Disconnect Existing Cable

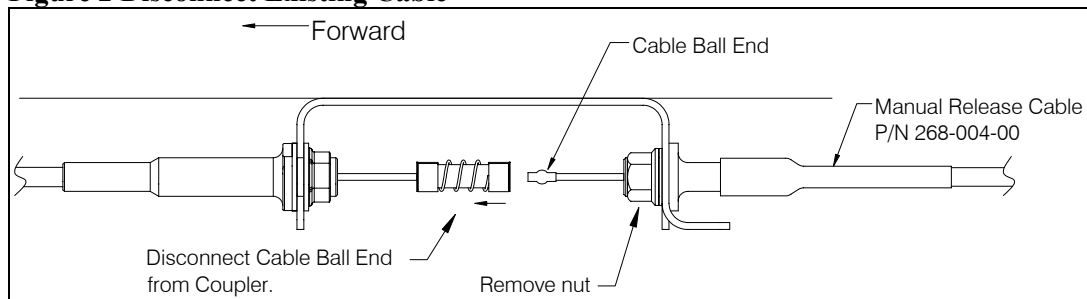

4. Remove the manual release cover from the cargo hook (see Figure 3).

- At the cargo hook unthread the b-nut that secures the manual release cable to the cargo hook release fitting.

Figure 3 Disconnecting Cable from Cargo Hook

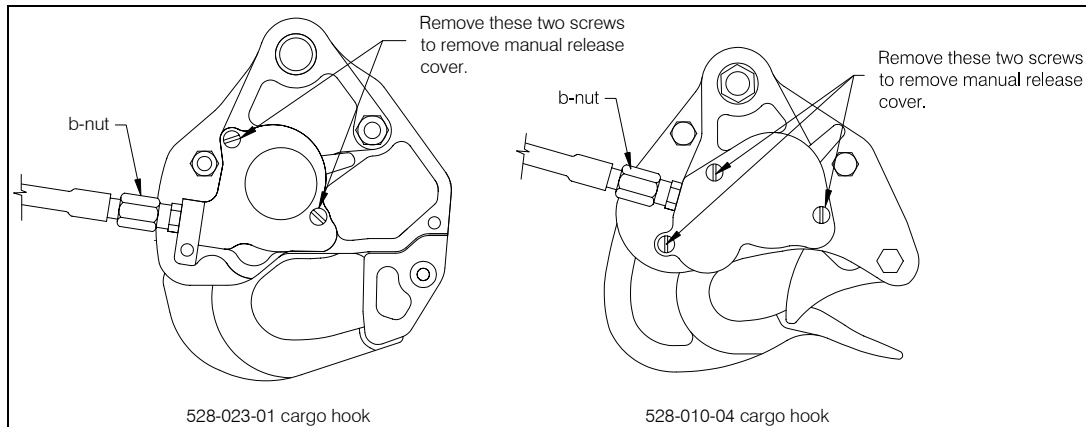

- Disengage the cable ball end from the fork fitting of the cargo hook and pull the cable out of the cargo hook.

Install new manual release cable

- Remove the nut from the end of the new Manual Release Cable (P/N 268-004-01), insert the end fitting through the hole in the bracket, and re-install the nut over the end fitting to secure it to the bracket.
- Retract the spring loaded end of the coupler and insert the cable ball end.

NOTICE

The following instructions are for Onboard Systems Cargo Hooks. If another make of cargo hook is used, follow the manufacture's instructions for installing and rigging the mechanical release cable.

- At the cargo hook insert the inner cable through the release cable adapter fitting and the fork fitting (see Figure 4)
- Thread the manual release cable's b-nut onto the release cable adapter fitting and tighten securely.
- Verify the Manual Release Cable is rigged correctly by rotating the manual release lever in the clockwise direction to remove free play (this is felt as the lever rotates relatively easily for

several degrees before free play is taken up) and measure the gap between the cable ball end and the fork fitting as shown in Figure 4. This gap should be a minimum of .125 inches (3.2 mm).

Also refer to the applicable Owner's Manual for detailed information on the Manual Release Cable rigging.



Failure to appropriately rig the manual release cable free play will result in uncommanded release of load.

Figure 4 Manual Release Cable Installation (528-023-01 cargo hook shown)

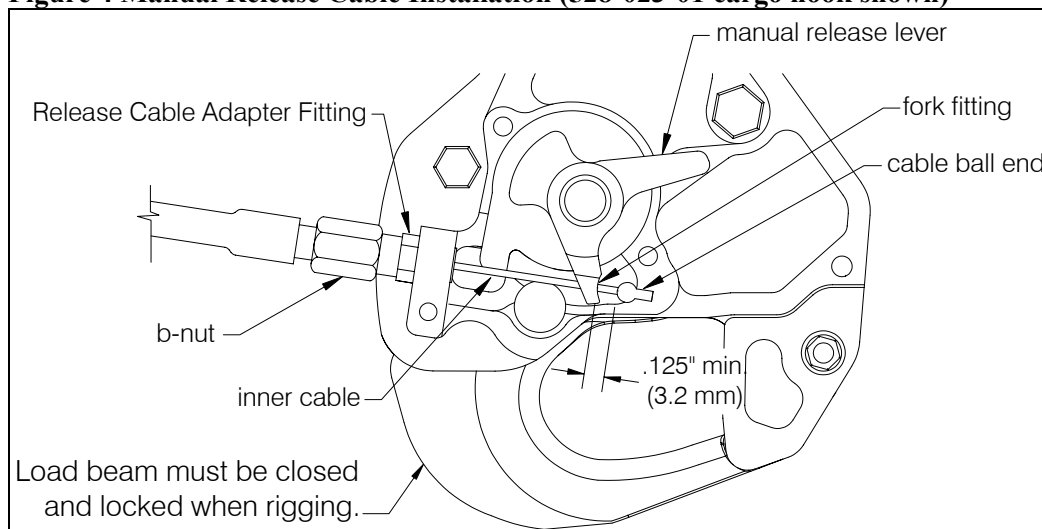

Adjustment of the manual release cable free play must be accomplished with the cargo hook in the closed and locked position.



Service Bulletin
Document: 159-030-00
Revision: 0 Date: August 1, 2011

12. Re-install manual release cover and secure screws with safety wire.
13. Verify manual release system function by pulling the release handle in the cockpit and ensuring the cargo hook load beam opens (the 528-010-xx series and 528-017-xx series of cargo hooks require approximately 7 lbs to open).